



## A METHOD TO DESIGN VIBRATORY BOWL FEEDER BY USING FEM MODAL ANALYSIS

Giang-Nam Le<sup>1,\*</sup>, Van-Mui Nguyen<sup>1,2</sup>, Anh-Tu Dang<sup>1</sup>

<sup>1</sup>*School of Mechanical Engineering, Hanoi University of Science and Technology,  
No. 1, Dai Co Viet, Hai Ba Trung, Ha Noi*

<sup>2</sup>*Department of Mechanical Engineering, University of Economic and Technical Industries,  
No.456, Minh Khai, Hai Ba Trung, Ha Noi*

\*Email: [nam.legiang@hust.edu.vn](mailto:nam.legiang@hust.edu.vn)

Received: 20 July 2018; Approved for publication: 12 December 2018

**Abstract.** In the modern industry, vibratory bowl feeders have been widely used to provide small and light components. However, the structures of the sorting bowls vary according to the part types, which make oscillation mechanism of vibratory bowl feeders complicated and difficult to identify by using mathematical methods. Thus, such vibration mechanism is commonly identified by experimental method. This paper presents a numerical simulation study, using the finite element method with modal analysis on the ANSYS Workbench platform, to determine the fundamental frequencies of the mechanical system and to affirm the design and manufacture parameters of the vibratory bowl feeders. Then an experiment was conducted to verify the results which confirm that the simulation model can be used to identify parameters of the bowl's structure before the device is manufactured.

**Keywords:** vibratory bowl feeder, modal analysis, natural frequency, sorting bowl.

**Classification numbers:** 5.1.3, 5.5.1, 5.4.2.

### 1. INTRODUCTION

The capacity of part transfer depends on the proportion of parts in the right direction being removed from the bowl in a unit of time. During the part transfer process, the parts move inside the bowl (1) with the orientation structures and comes out in the required orientation [1]. To accomplish this, an automatic vibratory bowl feeder has been designed as in Figure 1. The parts are scattered randomly inside the bowl (1) which is mounted on the upper vibrator (2). The electromagnetic induction between the coil fixed to the upper vibrator (2) and the electromagnet (4) fixed to the lower vibrator (5) provides vibration to the sorting bowl by rotating movements around the vertical axis and the back and forth movements of the leaf spring (3), so that the parts are classified and oriented in a specific direction. The interaction force between two parts of the electromagnet is controlled by changing the voltage from a controller. Cushion rubber (6) can deteriorate the system's vibrations that affect other devices. However, the process to assure the

parts orientation and feeding capacity relies on following factors: frequency, electromagnet's vibration amplitude and sorting bowl structure [2 – 7]. Operating under the influence of the electromagnet's vibration, the mechanical system can oscillate in many different frequencies depending on the exciting force's frequency, and the system's mass and stiffness. Previously, there were studies about this matter which were conducted by comparing the theories with the numerical model [2] or by comparing the numerical model with experimental results [3]. In which, the operating frequency should be from 90 Hz to 110 Hz to optimize the performance of the vibratory bowl feeder while the specific frequency [3] of the system should be equal to the attractive force one. For the constant frequency devices, by conducting experiments, Giang-Nam Le and Van-Mui Nguyen [8] point out that the specific frequency of a vibratory bowl feeder for part transfer is as twice as the current frequency of the electromagnet. Therefore, the dynamic behaviour of the mechanical system through its natural frequency in relation to the input parameters (current frequency and the electromagnet's voltage) needs to be determined to create the design alternatives.

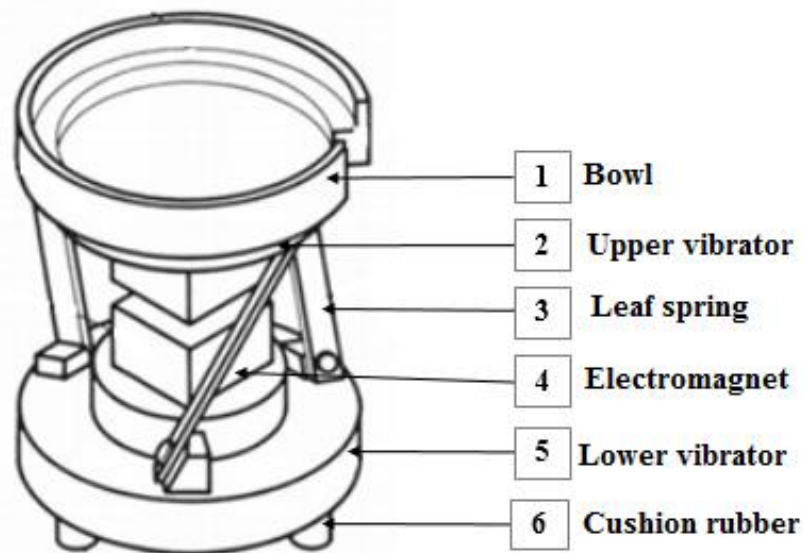

*Figure 1.* Automatic vibratory bowl feeder.

By using numerical simulating analysis, this paper proposes a method of designing vibratory bowl feeders by identifying the mechanical system's natural frequency which is suitable with the frequency of the electromagnet's electric current. The results of the numerical simulation analysis are used to fabricate a machine and are experimentally analyzed to verify.

## **2. THE DESIGN OF A VIBRATORY BOWL FEEDER**

### **2.1. The sorting bowl design**

The sorting bowl is designed in terms of shape selection [7]. Calculation process is expressed as in Figure 2. Input parameters such as: shape, size, part's material and required capacity are used to design the bowl (1) in Figure 1, and the materials are selected to keep parts clean in general and sterile in case of bowl for food and medical. For the parts moving along the

track, the step and angle of track were calculated, thus determining the bowl's diameter. According to the expected capacity, the height of the bowl must be calculated to assure the sufficient capacity to hold the parts. The calculation of the bowl's parameters is shown in Table 1.

## 2.2. The suspension system design

The suspension system (Figure 1) consists of: Upper vibrator (2), Leaf spring (3), Electromagnet (4), Lower vibrator (5), and Cushion rubber (6). The suspension system is designed based on calculation and catalogue selection [7]; the calculation process is described in Figure 3. With the input parameters including the size and weight of the bowl with (and without) the required parts calculated in the above part, the upper vibrator's size is measured to be compatible with the bowl and the required material. The leaf spring is estimated to assure that the VBF system can be controlled to vibrate in resonant manner [7].

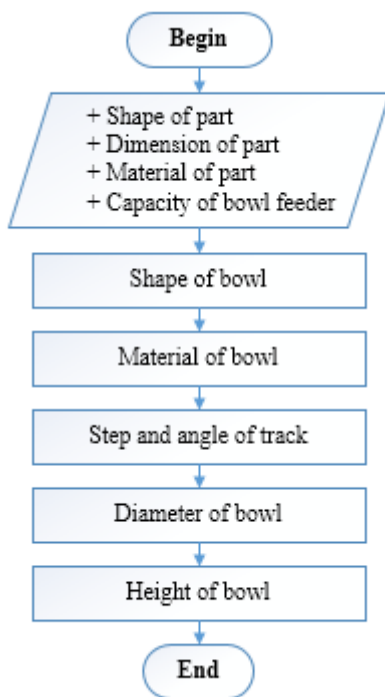

Figure 2. Process of designing the bowl.

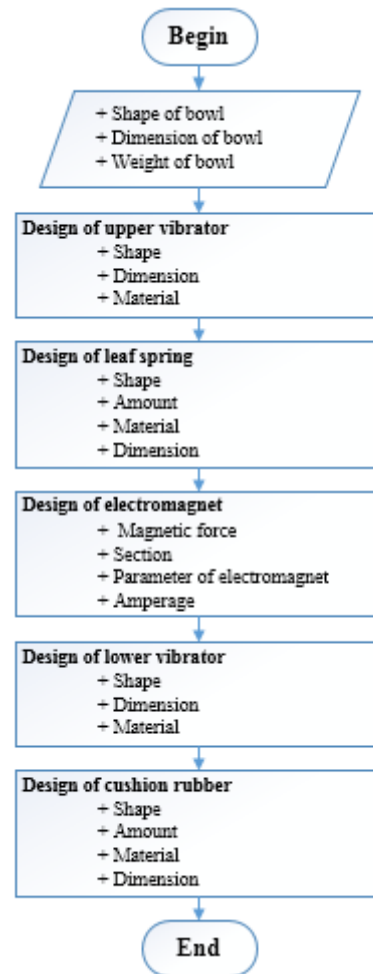

Figure 3. Process of designing the suspension system.

The electromagnet is calculated to identify the necessary traction force for the parts to move upwards in accordance with the required capacity. Thereupon, the cross-section,

parameters as well as the voltage are also evaluated. To keep the system in a steady position so that the lower vibrator (5) is measured to guarantee that the weight of the leaf spring's lower part is 5÷7 times heavier than those of the upper part. To avoid the system's vibration influence on other devices, a rubber cushion (6) is designed with the oscillation frequency lower than the resonant vibration frequency, so the phases of the forced oscillation and the rubber cushion's natural oscillation are reversed. The obtained results are presented in Table 1.

### 2.3. The technical parameters of calculated VBF.

Applying for the required parts as the rubber caps of vaccine bottles, calculation results and the bowl's size parameters are presented in Table 1. Materials and their properties for the components of VBF are looked up and displayed in Table 2. To link the components, the standard bolt-nut joints are used.

*Table 1.* The parameters of the VBF's mechanical structure for vaccine bottle's caps.

Component	Material	Size (mm)
Bowl	SUS 304	Diameter: 372 Height: 100 step of track: 40
Mounting adapter	50MnCrVA Steel	Outer diameter: 140 Inner diameter: 130 Height: 5.5
Upper vibrator	Cast iron	Outer diameter: 284 Height: 110
Leaf spring	50MnCrVA Steel	Length: 110 Width: 35 Thickness: 2
Lower vibrator	Cast iron	Diameter: 290 Height: 140

*Table 2.* Material properties of mechanical components.

Material	Specific weight (kg/m <sup>3</sup> )	Elastic modulus (x10 <sup>11</sup> Pa)	Poisson's ratio
SUS 304	7850	2.1	0.305
Cast iron	8545	1.06	0.324
50CrMnVA Steel	7800	2.1	0.300

### 2.4. System's vibration equation

Vertical vibration equation (Z) [9]:

$$M \cdot \ddot{Z} + R \cdot \dot{Z} + K \cdot Z = F_0 \cdot (\sin(\omega \cdot t))^2 \quad (1)$$

in which:  $M$  - Mass of the components on the leaf spring;  $R$  - Critical damping;  $K$  - System's hardness;  $F_0$  - Electromagnetic force;  $\omega$  - Angular frequency of the exciting current.

Transform equation (1) we get:

$$M \cdot \ddot{Z} + R \cdot \dot{Z} + K \cdot Z = \frac{F_0}{2} \cdot (1 - \cos(2 \cdot \omega \cdot t)) \quad (2)$$

The equation (2) shows that the electromagnetic force is divided into two parts: a constant part and a periodic variable part. The frequency of the periodic variable part is as twice as that of the exciting current. Therefore, the VBF's oscillation is a forced vibration excited by the electromagnetic force with a frequency having a double value compared to the current frequency [7, 9]. Hence, when the input current's frequency is 50 Hz, the frequency of the exciting force is 100 Hz, which means the system should be designed to have the natural frequency of 100 Hz.

### 3. MODELING AND SIMULATION

#### 3.1. Modeling the vibratory bowl feeder

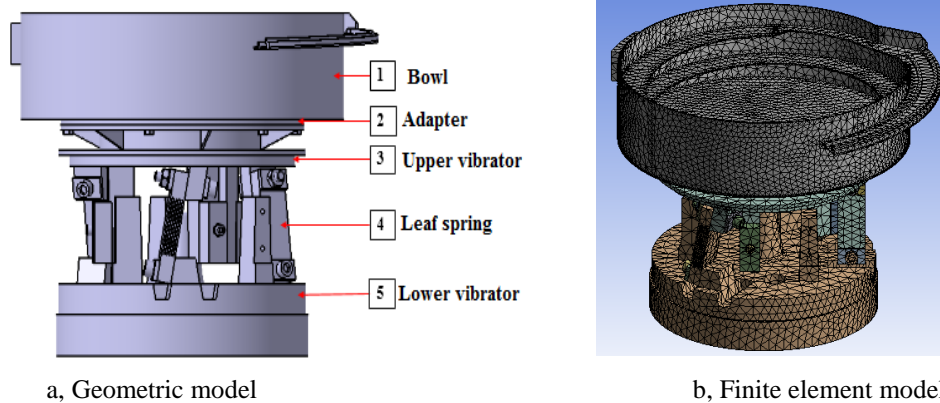

Figure 4. Geometric and finite element model of the vibratory bowl feeder.

The system's natural frequency depends only on the stiffness  $K$ , mass  $M$  (including leaf spring and the upper components of the leaf spring), and the contact between the leaf spring and the lower vibrator [9]. Thus, based on the parameters calculated in part 2.3, the geometric model of the VBF for vaccine bottle's caps is presented in Figure 4a, and the finite element model (Figure 4b) are used to analyze and determine the system's natural frequency. In the finite element model, the elements used for modelling are the tetrahedron Solid187, and Contac174 and Targe170 are used for bonds. This model contains 73459 elements and 144634 nodes. The materials for the components are described in Table 1 and their properties are shown in Table 2. The boundary conditions that include the bottom surface of the lower vibrator is fixed, other is free and pre-stress is set to none.

#### 3.2. Simulation tools

Ansys Workbench is a set of commercial software which is used worldwide to analyze and solve scientific and technical problems, including modal analysis. In this research, the Modal Analysis module of Ansys Workbench software is used to simulate and analyze the vibration

modes at some fundamental specific vibration frequencies of the system. Thus, determining the real operating modal of the system through simulation as well as proposing the design plans to avoid those modals that might cause damage to the operation of the system when there are the force directions, along with respective affecting frequencies.

### 3.3. Simulating process on Ansys Workbench

The module Modal Analysis of Ansys relies on theoretical calculation. The system's natural frequency is calculated by the following equation:

$$\det([K] - \omega^2[M]) = 0 \quad (3)$$

in which:  $[M]$  and  $[K]$  are respectively the mass matrix and stiffness matrix of the system, created from the respective parameters of an excited system.

Solving by the finite element method, the modal analysis allows identifying fundamental frequencies and oscillation modes of the system at these frequencies (the process is shown in Figure 5). In which, the numerical model representing the system includes geometric model, element model, connection and materials' properties as in part 3.1. The scope of modal analysis is defined to 6 fundamental frequencies which are suitable with the real operation scope of this machine.

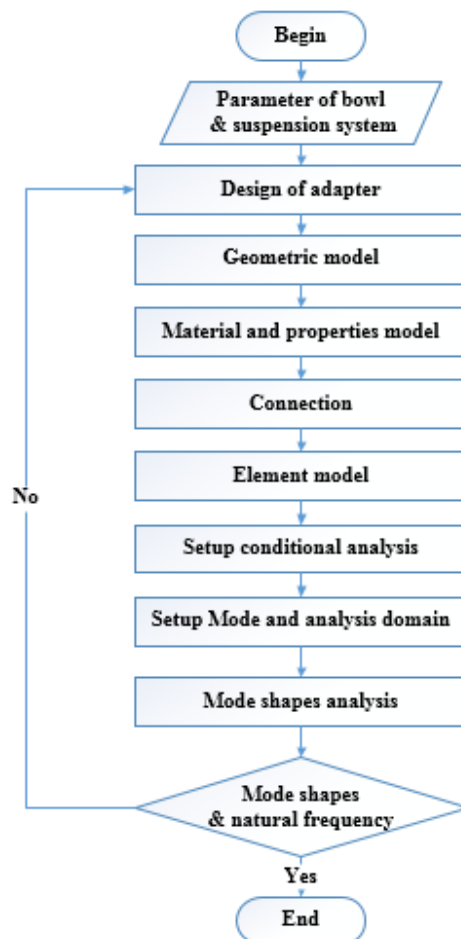
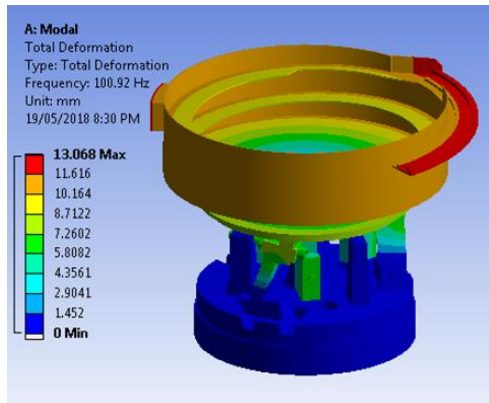

Figure 5. Process of Modal Analysis on Ansys Workbench.

### 3.4. Simulation results

The simulation results show the system's modes at different natural frequencies of the bowl as in Figure 6.



a, Rotating around axis Z (100.92 Hz)

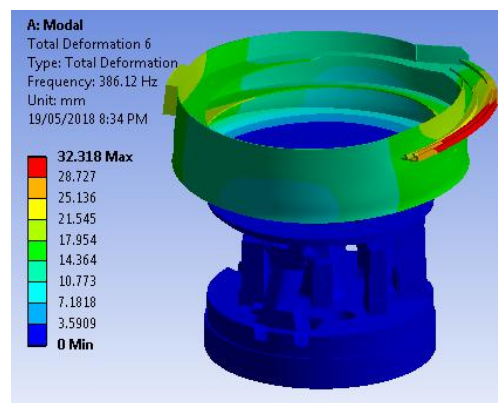

b, Sliding along axis Z (386.12 Hz)

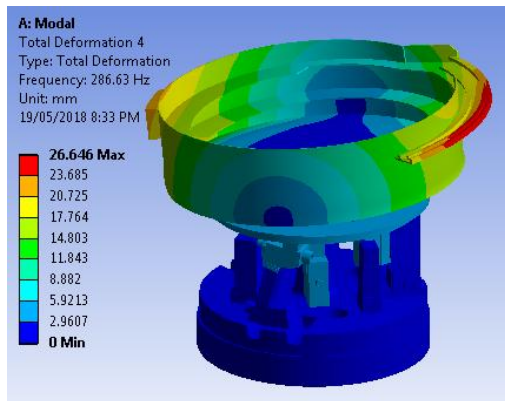

c, Rotating around axis Y (286.63 Hz)

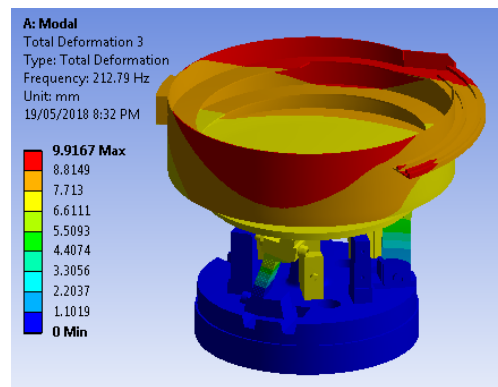

d, Sliding along axis Y (212.79 Hz)

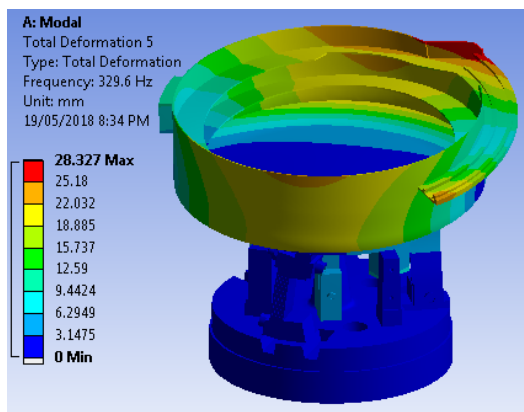

e, Rotating around axis X (329.6 Hz)

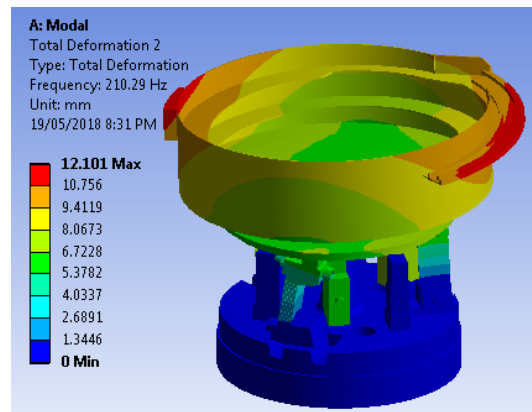

f, Sliding along axis X (210.29 Hz)

Figure 6. Movement modals of the system at different fundamental natural frequencies.



The simulation results show that the movement modals at the vibration frequencies are similar to the research of Kadam and Pisotre (2017) [3]. At the specific oscillation frequency of 100.92 Hz, the mode contains the rotation around the axis of symmetry, coinciding with the operation modal of the vibratory bowl feeder. Hence, verifying the parameters and material of the bowl, as well as the mounting adapter that connects the bowl with the suspension system so that the system's natural frequency could be equal to the frequency of the attractive force, and as twice as the frequency of the electric current accomodating the electromagbet.

#### **4. FABRICATION AND EXPERIMENT**

To test the results of design analysis, the authors have created a vibratory bowl feeder for rubber caps of vaccine bottles with the parameters mentioned in part 2.3. The measuring instrument VIBROPOST 80- Brüel & Kjær Vibro is used to identify the system's natural frequency. The tested device and the measuring instrument are set up as in Figure 7 – this method is also suitable with the published alternatives [1 – 3], thus identifying the system's natural frequencies. The obtained results are the displacement of the caps over time, the response frequency of the system, and the natural vibration frequency of the machine's components.

##### **4.1. Circuit and measuring instrument**

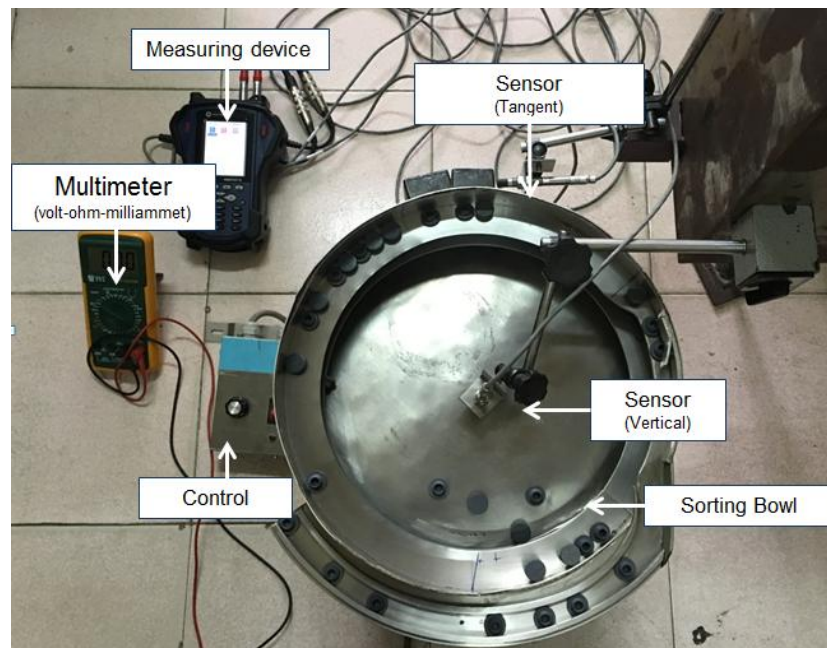

*Figure 7. Circuit and measuring instrument VIBROPOST 80.*

The measuring instrument uses two proximity sensors which allow measuring vibration amplitude and frequency without direct contact. VIBROPOST 80 can connect to 4 modules, so it can simultaneously measure both vertical and tangential oscillations. In addition, this instrument can also identify specific frequency of each component of the system. With external memory, VIBROPOST 80 can process the measured data right in the device. The measuring instrument's technical information is included in Table 3.



Table 3. Technical information of VIBROPOST 80 - Brüel & Kjær Vibro.

Technical information	Measuring scope
Parameters	Velocity, acceleration, displacement, frequency
Frequency range	0.18 Hz – 80 kHz
Number of modules	4
Screen	VGA/LCD color screen
Screen size	220 × 220 × 71 mm
Signal processing	On screen or on computer
Displayed signal	Simultaneously (vt, gt, cv, ts)
Specific frequency measurement	Yes
External memory	16 Gb SD/SDHC
Internal memory	128 Mb
Computer connecting software	ReX PC
Security level	IP65

#### 4.2. Experiment results and result processing

Experiment results show that the rubber caps move properly along the classification grooves. To facilitate the research study, the authors haven takes the data of vertical displacement and rotating angles over time and processed them with ReX software which is specially developed for VP80. After processed, the results include the system’s response frequency and the oscillation amplitude (Figure 8).

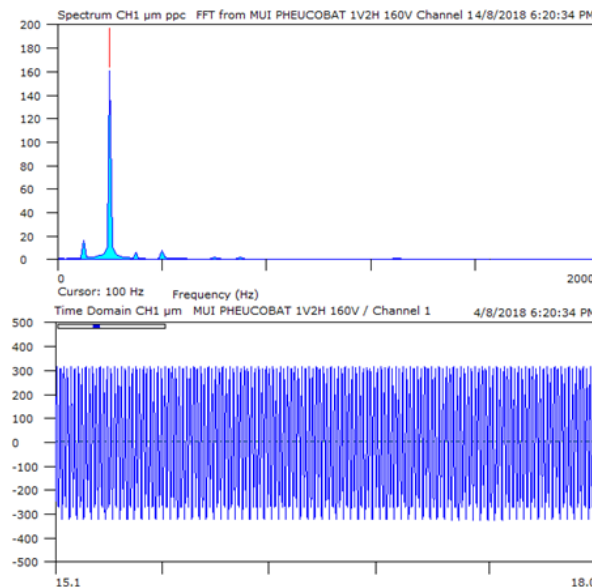

Figure 8. Specific frequency and oscillation amplitude.

In the Figure 8, we can see that the vibration amplitude of the bowl depends on the voltage. As the voltage increases, the amplitude also increases. However, no matter what the voltage value is, the specific oscillation frequency of the system is always 100 Hz.

## 5. CONCLUSION

Dynamic responses indicate that operating frequency of the system is 100 Hz, adequate with the frequency of attractive force (100 Hz). This is the resonant phenomenon occurring when forced oscillation concurs with the system's specific oscillation frequency. This result affirms that the design and simulation alternative is similar to the experiment. Meanwhile, it also proves that the recommendation plan with a constant current frequency accommodated the electromagnet. In addition, the system's structure could be designed to have the natural frequency be equal with the attractive frequency by modal analysis. This alternative should be used to design vibratory bowl feeder for other sporadic, small and light parts.

**Acknowledgment:** The researchers would like to express our sincere gratitude to VIMESGROUP for supporting us with instruments for measurement, simulation and experiment in this research.

## REFERENCES

1. Mucchi E., Di Gregorio R., and Dalpiaz G. - Elastodynamic analysis of vibratory bowl feeders: Modeling and experimental validation, *Mech. Mach. Theory* **60** (2013) 60–72.
2. Choi S. B. and Lee D. H. - Modal analysis and control of a bowl parts feeder activated by piezoceramic actuators, *J. Sound Vib* **275** (1–2) (2004) 452–458.
3. Kadam Abhijit and Pisotre Manjunath - Modal Analysis of Vibratory Bowl Feeder Machine, *IJRMEE* **4** (12) (2017) 5–10.
4. Park Y.M., Lee H.J., Lee Y.J., Yang H.L., Chang Y.B, Park K.R., Chu Y., Yonekawa H., Kim Y.O., Song N.H., Kwag S.W., Woo I.S., Park H.T., and Bak J.G. - Design, fabrication and commissioning of the KSTAR TF current feeder system, *Fusion Eng. Des* **86** (6–8) (2011) 1440–1444.
5. Le Giang Nam and Nguyen Van Mui - Evaluate the effects of vibration frequency to the dynamic parameters of parts in vibrational automatic bowl feeder using numerical simulation (in Vietnamese), *Vietnam National Conference on Mechanics* (1) (2014) 149-154.
6. Boothroyd Geoffrey, *Assembly automation and product design*, 2005.
7. Tran Van Dich, *Manufacturing Automation* (in Vietnamese), Vietnam Science and Technics Publishing House, 2006.
8. Le Giang Nam and Nguyen Van Mui - A method investigating vibrational automatic feeder by experiments (in Vietnamese), *Vietnam National Journal of Mechanical* (6) (2018).
9. Vilán Vilán J. A., Segade Robleda A., García Nieto P.J., and Casquerio Placer C. - Approximation to the dynamics of transported parts in a vibratory bowl feeder, *Mech. Mach. Theory* **44** (12) (2009) 2217–2235.