

Summer 2011

Development of a High Speed Data Acquisition System for Spark Ignition Engine

Cory Levette Griswold

Follow this and additional works at: <https://digitalcommons.georgiasouthern.edu/etd>

Recommended Citation

Griswold, Cory Levette, "Development of a High Speed Data Acquisition System for Spark Ignition Engine" (2011). *Electronic Theses and Dissertations*. 775.
<https://digitalcommons.georgiasouthern.edu/etd/775>

This thesis (open access) is brought to you for free and open access by the Graduate Studies, Jack N. Averitt College of at Digital Commons@Georgia Southern. It has been accepted for inclusion in Electronic Theses and Dissertations by an authorized administrator of Digital Commons@Georgia Southern. For more information, please contact digitalcommons@georgiasouthern.edu.

DEVELOPMENT OF A HIGH SPEED DATA ACQUISITION SYSTEM FOR SPARK
IGNITION ENGINE

by

CORY GRISWOLD

(Under the Direction of Frank Goforth)

ABSTRACT

Full engine control can only be accomplished with multi-input multi-output (MIMO) control system requiring measurement of variables for which no sensor/instrument is yet available in the Renewable Energy and Engines Laboratory, therefore a less detailed single input single output (SISO) engine model is developed. To develop the engine controller a model of the engine had to first be determined. Known Discrete-Event and Mean-Value models were the first choice, but could not be utilized because of the nature of the single cylinder intake manifold pressure. Therefore an engine model based on experimental data had to be developed. Using Matlab/ Simulink, xPC Target and data acquisition hardware a model of the single cylinder engine was developed. These models were developed by taking measurements of the engines dynamics such as engine speed, crank angle, air mass intake, spark timing, injection timing, and intake temperatures at different engine speed set points while running gasoline and then a gasoline and ethanol mix (E85). From which experimental coefficients were determined necessary for the model.

INDEX WORDS: Spark Ignition, SI Engine, High Speed Data Acquisition,
Single Cylinder Engine

DEVELOPMENT OF A HIGH SPEED DATA ACQUISITION SYSTEM FOR SPARK
IGNITION ENGINE

by

CORY GRISWOLD

B.S., Georgia Southern University, 2008

A Thesis Submitted to the Graduate Faculty of Georgia Southern University in Partial
Fulfillment

of the Requirements of the Degree

MASTER OF SCIENCE

STATESBORO, GEORGIA

2011

© 2011
CORY GRISWOLD
All Rights Reserved

DEVELOPMENT OF A HIGH SPEED DATA ACQUISITION SYSTEM FOR SPARK
IGNITION ENGINE

by

CORY LEVETTE GRISWOLD

Major Professor: Frank Goforth
Committee: Valentin Soloiu
Yan Wu

Electronic Version Approved:
July 2011

ACKNOWLEDGMENTS

I would like to thank my Mom and Dad for support through my college career and especially graduate school. Also thank my thesis advisor Dr. Goforth for coaching me through the thesis process. Dr. Soloiu for his insight and allowing me to work inside the Renewable Energy Laboratory. Last, the many other Georgia Southern Applied Engineering Graduate Students for their help and knowledge.

TABLE OF CONTENTS

	Page
ACKNOWLEDGMENTS	5
LIST OF TABLES	9
LIST OF FIGURES	11
CHAPTER	12
1 INTRODUCTION.....	13
1.1 Nomenclature	15
2 LITERATURE REVIEW	17
2.1 Throttle Body/ Intake Manifold/ Air /Fuel Mixture Models and Engine	19
2.1.1 Quasi-Steady	19
2.1.2 Filling and Emptying Model	20
2.1.3 Gas Dynamic Models	22
2.1.4 Extensions of Heywood’s Intake and Air/ Fuel Mixing Models	24
2.2 In-Cylinder Combustion Models	30
2.2.1 Thermodynamic/ In-Cylinder Combustion Models	30
2.2.2 Spark-Ignition (SI) In-Cylinder Combustion Models	33
2.2.3 Fluid-Mechanic Model	34
2.2.4 Extension to Heywood’s In-Cylinder Combustion Models	35
2.2.4.1 Torque Production/ Combustion	36
2.2.4.1.1 The Willan’s Approximation:	36
2.2.4.1.2 Other Torque Models	38
2.2.4.1.3 Other Variations	42
3 ENGINE MODELING.....	44
3.1 Intake Manifold Dynamics.....	44
3.2 Engine Air Mass Flow	49
4 METHODOLOGY	55
4.1 LabView for Data Acquisition.....	55
4.1.1 LabView Limit Testing.....	59
4.1.1.1 Sine Wave.....	59
4.1.1.2 Quadrature Encoder.....	63
4.1.1.3 Encoder Signal	64
4.1.1.4 LabView with Rotary Encoder	64
4.1.1.5 Encoder Signal Testing	68

4.2	The Switch to MatLab/Simulink/xPC Target	70
4.2.1	Analog and Digital Signals	77
4.2.2	Target Machine Benchmark	79
4.2.3	DC Motor and Offline Testing	79
4.2.4	Building Stands and Assembly	79
4.2.5	DC Motor Setup Issues	81
4.3	Preparation for System Testing	81
4.3.1	Control of DC Motor	82
4.4	Sensors	86
4.4.1	Crankshaft Rotary Encoder	86
4.4.2	Flow System Measurements	87
4.4.3	Mass Air Flow	89
4.4.4	Throttle Position Sensor (TPS)	90
4.4.5	Injection Sampling Circuit	91
4.4.6	Second Injector Sampling Circuit	94
4.4.7	Thermocouple	95
4.4.8	Thermocouple Data Acquisition	96
4.4.9	Wideband O ₂ Sensor	97
4.5	Signal Conditioning and Sensors	98
4.5.1	First Attempt Encoder Dividers	98
4.5.2	Encoder Signal Issues	99
4.5.3	Second Encoder Divider	101
4.5.4	Wiring of Signals	101
4.5.5	Inductive Sensor	101
4.5.6	Preliminary Data from Inductive Clamp	104
4.5.7	Single Cable Connection	105
4.6	MatLab Code and System Status	105
5	ENGINE MAPS	107
5.1	Fuel Injection	107
5.2	Spark Timing	107
6	EXPERIMENTAL DATA	109
7	RESULTS	118
8	CONCLUSION	128
	REFERENCES	129

APPENDICES	132
Appendix A LINEARIZATION	132
Appendix B SIGNAL GATHERING CODE	142
Appendix C EXPERIMENTAL DATA.....	153

LIST OF TABLES

Table 1.1: Small SI Non-Handheld Engine Exhaust Emission Standards	13
Table 4.1: Test Engine Characteristics	55
Table 4.2: List of Sensors, Measured Variables and Expected Maximum Frequency of Change	56
Table 4.3: LabView Settings for Quadrature Encoder Card.....	66
Table 4.4: PCI-QUAD04 settings in MatLab	75
Table 4.5: Host and Target Computer System Properties	76
Table 4.6: Maximum Input Frequency of PCI Data Acquisition Cards	76
Table 4.7: Settings for Analog Input for PCI-1602/16	78
Table 4.8: Settings for Digital Input of PCI-1602/16 for Injector Timing	78
Table 4.9: Settings for Digital Input of PCI-1602/16 for Spark Timing	78
Table 4.10: Sensors and Maximum Frequency of Measure	86
Table 4.11: Results of Dividing Encoder Counts on Resolution and Frequency	98
Table 4.12: Serial Connection Position	105
Table 7.1: Steady State Coefficients for Briggs and Stratton Engine.....	120
Table 7.2: Gasoline: Average Injection Angle During Intake Stroke.....	124
Table 7.3: Gasoline: Average Ignition Angle During Expansion Stroke	125
Table 7.4: Gasoline: Average Low Injection Duration.....	125
Table 7.5: Gasoline: Average High Injection Duration	125
Table 7.6: E85: Average Injection Angle	126
Table 7.7: E85: Average Ignition Angle.....	126
Table 7.8: E85: High Average: Injection Duration in Seconds	126
Table 7.9: E85: Low Average: Injection Duration in Seconds.....	127
Table C.1: E85- Mass Air Flow and Intake Manifold Pressure.....	153
Table C.2: Gasoline-Mass Air Flow and Intake Manifold Pressure.....	154
Table C.3: Gasoline: Minimum Injection Angle	161
Table C.4: Gasoline: Maximum Injection Angle.....	161
Table C.5: Gasoline: Average Ignition Angle	162
Table C.6: Gasoline: Maximum Ignition Angle	162
Table C.7: Gasoline: Maximum Injection Angle.....	162
Table C.8: Gasoline: Average Injection Angle.....	162
Table C.9: Gasoline: Minimum Injection Angle	163
Table C.10: Gasoline: Minimum Ignition Angle.....	163
Table C.11: Gasoline: Maximum Ignition Angle	163
Table C.12: Gasoline: Minimum Ignition Angle.....	163
Table C.13: Gasoline: Minimum Low Injection Duration.....	163
Table C.14: Gasoline: Maximum Low Injection Duration.....	164
Table C.15: Gasoline: Maximum High Injection Duration	164
Table C.16: Gasoline: Minimum High Injection Duration.....	164
Table C.17: E85: Minimum Ignition Angle.....	164
Table C.18: E85: Maximum Injection Angle	164
Table C.19: E85: Minimum Injection Angle	165
Table C.20: E85: Minimum Ignition Angle.....	165
Table C.21: E85: Maximum Ignition Angle.....	165
Table C.22: E85: Average Injection Angle.....	165
Table C.23: E85: Maximum Injection Angle	165

Table C.24: E85: Minimum Injection Angle	166
Table C.25: E85: Average Ignition Angle	166
Table C.26: E85: Maximum Ignition Angle	166
Table C.27: E85: Minimum Ignition Angle.....	166
Table C.28: E85: High Minimum: Injection Duration.....	166
Table C.29: E85: High Maximum: Injection Duration	167
Table C.30: E85: Low Minimum: Injection Duration	167
Table C.31: E85: Low Maximum: Injection Duration.....	167

LIST OF FIGURES

	Page
Figure 2.1: Engine Idle Speed System (Guzzella & Onder, 2004).....	18
Figure 4.1: Diagram for Hardware Setup with LabView	58
Figure 4.2: Screen of LabView Program for Analog Input	62
Figure 4.3: Front Panel of LabView Analog Input Program	63
Figure 4.4: Frame 0 LabView Block Diagram Code for Quadrature Encoder.....	68
Figure 4.5: Frame 1 LabView Block Diagram Code for Quadrature Encoder.....	69
Figure 4.6: Frame 2 LabView Block Diagram Code for Quadrature Encoder.....	69
Figure 4.7: LabView Front Panel for Encoder Program.....	70
Figure 4.8: Diagram for Hardware Setup with for xPC Target	73
Figure 4.9: SimuLink Screen with xPC Target Blocks	74
Figure 4.10: Stand for Mounting Rotary Encoder to DC Motor Shaft.....	83
Figure 4.11: Top View of DC Motor with VR Sensor	83
Figure 4.12: Stand for VR Sensor.....	84
Figure 4.13: Output Tachometer Voltage versus NECO DC Motor Speed	84
Figure 4.14: Plotted data of encoder position versus VR sensor.....	85
Figure 4.15: Laminar Flowmeter Analog Output (Meriam,2010).....	88
Figure 4.16: Meriam Laminar Flow System (LFS) (Meriam, 2010).....	89
Figure 4.17: Mariam Laminar Flow Element (LFE) Z50MC2-2 (Meriam, 2010).....	89
Figure 4.18: Engine Throttle Positioning Sensor	90
Figure 4.19: Voltage versus Throttle Angle for TPS.....	91
Figure 4.20: MOSFET Injector Sampling Circuit	93
Figure 4.21: The Encoder Signal and Injector using First Injector Circuit	94
Figure 4.22: Circuit for inverting injector signal.....	95
Figure 4.23: Wideband Air to Fuel Ratio Sensor (Bosch, n.d.).....	97
Figure 4.24: Banebots Encoder Dividers to PCI-QUAD04.....	99
Figure 4.25: Inductive Clamp Signal Conditioning Circuit.....	103
Figure 4.26: Simulink Block for Injector Signal	103
Figure 4.27: Inductive Clamp Signal versus Time	104
Figure 4.28: Spark Signal versus Crank Angle	104
Figure 6.1: Gasoline: 1200 rpms at 0 Percent Open Throttle	111
Figure 6.2: Gasoline: 1200 rpms at 5 Percent Open Throttle.....	111
Figure 6.3: Gasoline: 1200 rpms at 10 Percent Open Throttle.....	112
Figure 6.4: Gasoline: 1200 rpms at 15 Percent Open Throttle.....	112
Figure 6.5: Gasoline: 1200 rpms at 20 Percent Open Throttle.....	113
Figure 6.6: E85: 1200 rpms at 0 Percent Open Throttle.....	113
Figure 6.7: E85: 1200 rpms at 5 Percent Open Throttle.....	114
Figure 6.8: E85: 1200 rpms at 10 Percent Open Throttle.....	114
Figure 6.9: E85: 1200 rpms at 15 Percent Open Throttle.....	115
Figure 6.10: E85: 1200 rpms at 20 Percent Open Throttle.....	115
Figure 6.11: Gasoline: Contour Plot Engine Speed vs. Percentage of Throttle Opening and Intake Mass Air Flow	116
Figure 6.12: E85: Contour Plot Engine Speed vs. Percentage of Throttle Opening and Intake Mass Air Flow.....	117
Figure 7.1: Estimation of Intake Air Mass Flow of Briggs and Stratton Engine	118

Figure 7.2: E85 Adjusted Predicted Intake Mass Air Flow	119
Figure 7.3: Gasoline Adjusted Predicted Intake Mass Air Flow	119
Figure 7.4: Throttle Angle Signal Versus Time at 1200 rpm	121
Figure 7.5: Throttle Angle Signal Versus Time at 2400 rpm	121
Figure 7.6: Throttle Angle Signal Versus Crank Angle at 1200 rpm and 0% Throttle Opening	122
Figure 7.7: Throttle Angle Signal Versus Crank Angle at 2400 rpm and 20% Throttle Opening	123
Figure C.1: Mass Air Flow and 1200 rpm and 0% Throttle	155
Figure C.2: Mass Air Flow and 1200 rpm and 5% Throttle	156
Figure C.3: Mass Air Flow and 1200 rpm and 10% Throttle	156
Figure C.4: Mass Air Flow and 1200 rpm and 15% Throttle	157
Figure C.5: Mass Air Flow and 1200 rpm and 20% Throttle	157
Figure C.6: E85 Mass Air Flow and 1200 rpm and 0% Throttle	158
Figure C.7: E85 Mass Air Flow and 1200 rpm and 0% Throttle	159
Figure C.8: E85 Mass Air Flow and 1200 rpm and 10% Throttle	160
Figure C.9: E85 Mass Air Flow and 1200 rpm and 15% Throttle	160
Figure C.10: E85 Mass Air Flow and 1200 rpm and 20% Throttle	161

CHAPTER 1

INTRODUCTION

The objective of this thesis research is to develop an instrumentation system to measure the operating characteristics of a single cylinder spark ignition fuel injection (SIFI) engine in order to develop a mathematic model of said engine sufficient to control the engine in real time. There are many of these small motors in use for various applications, and aspects of the motor's performance such as idle speed exhaust emissions and fuel efficiency can be better manipulated by computer control. These aspects of the engine's operations have an impact on the environment and cost of operating these motors, however controlling such a nonlinear system presents many challenges. The first challenge is to generate an accurate linear model that represents the engine system.

The reason the single cylinder engine is the engine of choice for controls is because there are millions of them and they are not very efficient in the amount of fuel it uses. The engines are also not very clean which caused more stringent regulations on emissions being put in place by the Environmental Protection Agency. The new regulations can be seen in Table 1.1 for non-handheld engines.

Engine Class Model Year	Model Year	HC+NO _x [g/kW-hr]	CO _a [g/kW-hr]
Class I (>80cc to <225cc) ^b	2012	10.0	610
Class II (≥225cc) ^a	2011	8.0	610

Table 1.1: Small SI Non-Handheld Engine Exhaust Emission Standards

^a 5 g/kW-hr CO for Small SI engines powering marine generators.

^b Nonhandheld engines at or below 80cc will be subject to the emission standards for handheld engines.

Environmental Protection Agency (2008)

These engines need to produce less pollutant emissions such as nitrogen oxide (NO_x), hydrocarbon (HC) and carbon monoxide (CO). These reductions in emissions can come from a change in fuel from gasoline to Ethanol 85% mix (E85). Changes in the fueling map and spark timing will be necessary.

A model of the engine must be researched, tested and then validated in order to complete the controls task. The engine model details the engines physical parameters. There are different models that can represent the same physical section of an engine, such as the filling and emptying model or the wave action charge model for the air intake system. Certain assumptions had to be made in order to simplify and generate a model that fit the needs of the research. For example, an assumption the intake manifold is an isothermal orifice helps simplify calculations. Not just any model would fit the criteria to effectively simulate the dynamics of the engine.

The engine model equations are comprised of engine level variables such as intake manifold pressure and engine speed with constants that either pertains to the engine or surrounding conditions. Some of the constant coefficients need to be found experimentally, while some need to be pre-calculated. System identification must be performed using the measured engine data in order to model the engine dynamics. The system identification will be performed at idle speed for the first test with measurements of variables such as engine speed, intake manifold pressure and intake air mass flow.

The non-linear engine model has to be linearized around several operating points. These operating points are the engine speed and intake manifold air pressure. The resulting model will be a linear gain schedule model in state space form.

The following constants, acronyms and variable notations will be used throughout this report.

1.1 Nomenclature

p_m	Pressure downstream, manifold pressure [Pa]
ω_e	Engine speed [rad/s]
\dot{m}_α	Air mass flow through throttle area [kg/s]
\dot{m}_β	Air mass flow exiting manifold [kg/s]
ϑ_α	Intake Manifold Temperature upstream of engine cylinder [K]
ϑ_m	Air Manifold Temperature [K]
p_e	Back pressure exhaust manifold [Pa]
p_α	Pressure upstream, ambient pressure [Pa]
u_α	Control signal input to throttle [0...1]
u	Velocity of air flow at position x [m/s ²]
A_α	Open area of throttle [m ²]
$\alpha_{th,0}$	Angle of throttle fully closed [degrees]
α_{th}	Throttle opening angle [degrees]
$A_{th,leak}$	Throttle opening area when $\alpha_{th} = \alpha_{th,0}$ [m ²]
R	Specific gas constant [J/kg K]
k	Ratio of specific heats [-]
\dot{m}_e	Engine Mass Flow [kg/s]
p_e	Exhaust manifold pressure [Pa]
V_d	Cylinder Displacement [m ³]
V_c	Compression volume at TDC [m ³]
V_m	Volume of intake manifold [m ³]
Θ_e	Engine Inertia [kg/m ²]
T_e	Engine Torque [Nm]
T_l	Actual Load Torque [Nm]
H_l	Lower Heating Value www.afdc.energy.gov HI=116,090 Btu/gal [J/m ³]
d_{th}	Throttle Diameter [m]
$t - \tau_{inj \rightarrow TC}$	Transport Delay [s]
γ_0	Volumetric Efficiency Coefficient 1 [-]
γ_1	Volumetric Efficiency Coefficient 2 [s]
γ_2	Volumetric Efficiency Coefficient 3 [s ²]
η_0	Willansparameter 1 [J/kg]
η_1	Willansparameter 2 [J s/kg]
β_0	Willansparameter 3 [Nm]
β_2	Willansparameter 4 [Nm s ²]
λ	Air to Fuel Ratio [-]
σ_0	Stoichiometric Air/fuel Ratio for Gasoline [-]
C_d	Discharge Coefficient [-]
A_T	Area of Nozzle or Orifice Throat [m ²]
p_0	Stagnation Pressure [Pa]
T_0	Stagnation Temperature [K]
p_T	Pressure of Nozzle or Orifice Throat [Pa]
\dot{m}	Mass Flow [kg/s]
\dot{f}	Rate of Change of Fuel Fraction [-]
f_j	Fuel Mass Fraction [-]

f	Fuel Fraction [-]
ρ	Density [kg/m^3]
V	Volume [m^3]
\dot{Q}_w	Total Heat Transfer Rate Across the Boundary [W]
ϕ	Fuel/ Air Equivalence Ratio []
\dot{m}_i	Mass flow through intake valve [kg/s]
\dot{m}_e	Mass flow through exhaust valve [kg/s]
p_c	Cylinder pressure [Pa]
l	Connecting rod length [m]
r	Crank radius [m]
ϕ	Crank angle [$^\circ$ or rad]
SI	Effect of spark advance angle on the engine torque [-]
MBT	Minimum spark advance for best brake torque [-]
A_p	Area of the piston [m^2]
V_{cyl}	Volume of cylinder [m^3]
W	Work output of engine [J]
CYL	Number of cylinders [-]
a	Sound speed [m/s]
U	Internal Energy [J]
a_0	Friction Loss Coefficient [-]
a_1	Friction Loss Coefficient [-]
a_2	Friction Loss Coefficient [-]
b_0	Pumping Loss Coefficient [-]
b_1	Pumping Loss Coefficient [-]
N	Pade Approximation Order [-]
MVM	Mean Value Engine Model [-]
DEM	Discrete Event Model [-]

CHAPTER 2

LITERATURE REVIEW

There have been many models created in the attempt to control the nonlinear engine process. Previous researchers have used models to fit their control needs. For different control strategies this portion of the thesis will outline the most commonly referenced engine models.

One very well referenced text on the internal combustion engine is Heywood's (1988) *Internal Combustion Engine Fundamentals*. Heywood gives details on real engine models that take into account fluid dynamics, heat-transfer, thermodynamics and kinetics fundamentals, or combinations of the four. Heywood gives details of models that simulate the engine dynamics, such as intake and exhaust flow models, thermodynamic in-cylinder models, and fluid dynamic models. The level of detail of these models is too complex for engine control purposes using computers in real-time. (Heywood, 1988)

Heywood's equations on engines start out as a basic, open thermodynamics system. Systems that can be described in this form include the cylinder volume and the intake and exhaust manifolds. This system can be used when the composition and state of the gas can be assumed to be uniform and when variations of the state and composition occur over time because of heat transfer, work transfer and mass flow across the systems boundaries. The important equations for thermodynamic based systems are the conservation of mass and conservation of energy; these equations use either time or crank angle as their independent variable.(J. Heywood, 1988)

Heywood defines the mass of fuel flow and the change in the fuel to air equivalence ratio, using the equations of conservation of mass, while for the conservation of energy the first law of thermodynamics is used. This set of equations fundamentally defines energy production of the

engine. The conservation of energy equations take into account the heat-transfer rate into the system and work-transfer rate out of the system, which is defined by the position displacement and equal to cylinder pressure times change in volume. The heat released by combustion is defined in the energy and enthalpy terms. Heywood defines the internal energy, enthalpy and density of the fluid as being characterized by the fluid temperature, pressure and fuel/air equivalence ratio (J. Heywood, 1988). The completed model is best understood by considering the major subsystems shown in Figure 2.1.

The engine system can be broken down into two main systems. Each system uses a dynamic equation that governs the whole system as well as algebraic equation that describes the engine physical system. These systems can be referred to as the air system and the mechanical system. The air system is primarily made up of mass air flow entering the manifold, intake manifold pressure, the mixing of the fuel and air that influences the air to fuel ratio. The level variable that governs over the air system is the intake manifold pressure. The mechanical system deals with the engines physical dynamic and therefore its combustion and torque production. The dynamic engine speed governs the mechanical system.

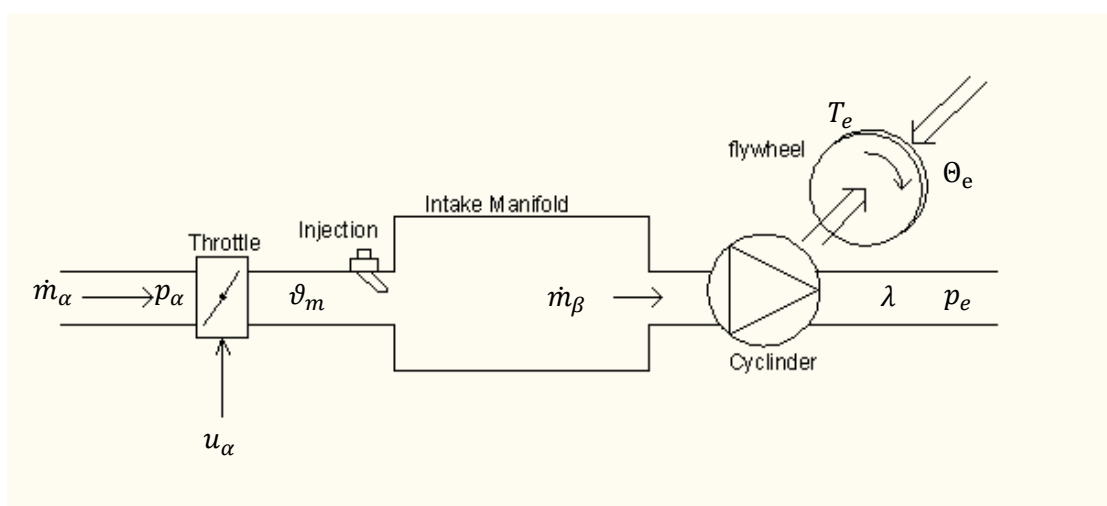

Figure 2.1: Engine Idle Speed System (Guzzella & Onder, 2004)

2.1 Throttle Body/ Intake Manifold/ Air /Fuel Mixture Models and Engine

Heywood details three intake and exhaust flow models. These models fall into the category of (1) quasi-steady model, (2) filling and emptying model and (3) gas dynamics model. Each will be further explained.

2.1.1 Quasi-Steady

The quasi-steady model concerns the flow around restrictions such as throttle port, air cleaner, and valves. The gas flow rate through each component is considered quasi steady. Guzzella and Onder (2004) use the same equations for flows around restrictions as the quasi-steady model presented by Heywood, as seen in Equation (2.1) and Equation (2.2). The two equations represent two conditions of compressible flow. Where Equation (2.1) is for subcritical flow and Equation (2.2) for choked flow. The variables in Equation (2.1) and Equation (2.2) are \dot{m}_α which is the mass air flow entering the intake manifold, c_d for the discharge coefficient which is the ratio of the real flow velocity through the orifice and the ideal flow velocity, A_T is throttle area, p_0 is the stagnation pressure, p_T is the pressure around the throttle, T_0 is the stagnation temperature, R is the gas constant and k is the ratio of specific heats. States within the equation include the pressure through the throttle (p_T) this would be equivalent to the engines intake manifold pressure. These equations are one-dimensional flow equations for mass flow rate into each cylinder. The quasi-steady models are used to calculate flow into and out of the cylinder through restrictions and mass flow rates into and out of the cylinder. Each of the restriction components are connected by the gas flow passing through them.

Quasi-steady models are useful for calculations of mass flow “into and out of the cylinder through the inlet and exhaust valves” as stated by Heywood (1988). A disadvantage of this, model as stated by Heywood (1988), is that the method cannot predict “the variations of

volumetric efficiency with engine speed, however, because many of the phenomena which govern this variation are omitted from this modeling approach.” This model also requires more knowledge on the engines operation than some of the later models that will be discussed.

$$\dot{m}_\alpha = \frac{C_d A_T p_0}{\sqrt{RT_0}} \left(\frac{p_T}{p_0}\right)^{1/\gamma} \left\{ \frac{2k}{k-1} \left[1 - \left(\frac{p_T}{p_0}\right)^{(k-1)/k} \right] \right\}^{1/2} \quad (2.1)$$

$$\dot{m}_\alpha = \frac{C_d A_T p_0}{\sqrt{RT_0}} k^{1/2} \left(\frac{2}{k+1}\right)^{(k+1)/2(k-1)} \quad (2.2)$$

2.1.2 Filling and Emptying Model

The second model is the filling and emptying model. This model takes into account the finite volume of critical components. The intake manifold can be analyzed as a single control volume where the mass of gas can increase or decrease with time. This model can be used to describe the how the air flow passing the throttle varies with increase in throttle angle. A simplified version of this model is used by Guzzella and Onder (2004) to describe the mass air flow rate entering the manifold, and some of the same assumptions are used. Such as the assumption the model represents a finite volume, and there is no change in volume with time. This model also assumes the composition of the gas does not change. The assumptions allow the filling and emptying model to be attractively simplified.

The filling and emptying model is able to predict the average variations of manifold dynamics over time, but not the spatial variations of the gas properties, because of unsteady gas dynamics. Heywood uses equations for mass and energy conservation as seen in Equation (2.3), Equation (2.4), Equation (2.5), Equation (2.6) and Equation (2.7). Along with Equation (2.1) and Equation (2.2) as was used with the quasi-steady model for flows around restrictions.

Where Equation (2.3) is the sum of mass flow. The simplification of the models by assuming a fixed volume and static gas composition makes calculations easier.(J. Heywood, 1988)

$$\dot{m} = \sum_j \dot{m}_j \quad (2.3)$$

Equation (2.4) details the rate of change of the fuel fraction which is a function of mass flows and fuel fractions.

$$\dot{f} = \sum_j \left(\frac{\dot{m}_j}{m} \right) (f_j - f) \quad (2.4)$$

Equation (2.5) details the dynamic of the pressure entering the open system. The variables include the density(ρ), volume(V), fuel air equivalence ratio(ϕ), temperature(ϑ), and mass.

$$\dot{p} = \frac{\rho}{\partial\rho/\partial p} \left(-\frac{\dot{V}}{V} - \frac{1}{\rho} \frac{\partial\rho}{\partial\vartheta} \dot{\vartheta} - \frac{1}{\rho} \frac{\partial\rho}{\partial\phi} \dot{\phi} + \frac{\dot{m}}{m} \right) \quad (2.5)$$

Then dynamic temperature of the open system can be solved using either Equation (2.6) or Equation (2.7). Where new variable u and h are the specific internal energy and specific enthalpy respectively.

$$\dot{\vartheta} = \left[B - \frac{p}{D} \frac{\partial u}{\partial p} \left(\frac{\dot{m}}{m} - \frac{\dot{V}}{V} + \frac{\partial R}{\partial\phi} \frac{\dot{\phi}}{R} \right) - \frac{\partial u}{\partial\phi} \dot{\phi} \right] / \left(\frac{\partial u}{\partial\vartheta} + \frac{C}{D} \frac{p}{\vartheta} \frac{\partial u}{\partial p} \right) \quad (2.6)$$

$$B = -R\vartheta \frac{\dot{V}}{V} + \frac{1}{m} \left(\dot{Q}_w + \sum_j \dot{m}_j h_j - \dot{m}u \right)$$

$$C = 1 + \frac{\vartheta}{R} \frac{\partial R}{\partial\vartheta}$$

$$D = 1 - \frac{p}{R} \frac{\partial R}{\partial p}$$

$$\dot{\vartheta} = \frac{B'}{A'} \left[\frac{\dot{m}}{m} \left(1 - \frac{h}{B'} \right) - \frac{\dot{V}}{V} - \frac{C'}{B'} \dot{\phi} + \frac{1}{B'm} \left(\sum_j \dot{m}_j h_j - \dot{Q}_w \right) \right] \quad (2.7)$$

$$A' = \frac{\partial h}{\partial \vartheta} + \frac{\partial \rho / \partial \vartheta}{\partial \rho / \partial p} \left(\frac{1}{\rho} - \frac{\partial h}{\partial p} \right)$$

$$B' = \frac{1 - \rho(\partial h / \partial p)}{\partial \rho / \partial p}$$

$$C' = \frac{\partial h}{\partial \phi} + \frac{\partial \rho / \partial \phi}{\partial \rho / \partial p} \left(\frac{1}{\rho} - \frac{\partial h}{\partial p} \right)$$

The Equation (2.3) through Equation (2.7) can be simplified for intake and exhaust flows since the volumes are fixed. Also the composition of the gases is assumed to be fixed.

The intake manifold dynamics can be modeled using Equation (2.8) with the filling and emptying model. Where η_v is the volumetric efficiency, V_d is the displacement of the volume, ω_e is the engine speed,

$$\frac{dp_m}{dt} + \frac{\eta_v V_d \omega_e}{2V_m} p_m = \dot{m}_{a,th} \frac{R\vartheta_m}{V_m} \quad (2.8)$$

2.1.3 Gas Dynamic Models

The gas dynamic model takes into account the volume variations in flow and pressure throughout the manifold. This model is used to study the engine gas exchange processes. The model takes into account many variables which include the length and cross-sectional area of both primary and secondary runners, the volume and location of the plenums, cylinder dimensions, number of cylinders, intake and exhaust port and valve design, and valve lift timing. Some variables such as enthalpy, heat-transfer, internal energy and changes with respect to

distance inside the engine cannot be measured in real-time. The equations include the unsteady flow equation. The model requires partial differential equations to solve many of the variables, and thus is too complex to solve in real time. (Heywood, 1988)

The gas dynamic model has the disadvantage compared to the previous mention models because the model requires dimensions and locations of engine features such as cross-sectional area and the entrance and exit angle at junctions of runners as well as intake and exhaust port designs.(J. B. Heywood, 1988)

To simplify these complex equations uses the method of characteristic and the finite difference method. The method of characteristics is used to solve hyperbolic partial differential equations, by changing the partial differential equation into an ordinary differential equation. As stated by Heywood, “the finite difference methods is used to solve one-dimensional unsteady flow equations in intake and exhaust manifolds” which is “proving more efficient and flexible that the method of characteristics.” (J. Heywood, 1988)

Mass Conservation:

$$\frac{\partial \rho}{\partial t} + \frac{\partial}{\partial x}(\rho U) + \frac{\rho U}{A} \frac{dA}{dx} = 0 \quad (2.9)$$

$$D = (4A/\pi)^{1/2} \quad (2.10)$$

$$\xi = \tau_w / \left(\frac{1}{2} \rho U^2 \right) \quad (2.11)$$

where t is time in seconds, x is the linear distance D is the equivalent diameter; ξ is the friction coefficient and is the τ_w shear stress on the walls.

Mass and Momentum Conservation:

$$\frac{\partial U}{\partial t} + U \frac{\partial U}{\partial x} + \frac{1}{\rho} \frac{\partial p}{\partial x} + 2\xi \frac{U^2}{D} = 0 \quad (2.12)$$

Energy Conservation:

$$\frac{\partial p}{\partial t} + U \frac{\partial p}{\partial x} - a^2 \left(\frac{\partial p}{\partial t} + U \frac{\partial p}{\partial x} \right) - (k-1)\rho \left(\dot{q} + 2\xi \frac{U^3}{D} \right) = 0 \quad (2.13)$$

$$a^2 = \left(\frac{\partial p}{\partial \rho} \right)_s = k \frac{p}{\rho} \quad (2.14)$$

where isentropic process is designated by the subscript s is used to solve for the sound speed (a) of an ideal gas as seen in Equation (2.14).

2.1.4 Extensions of Heywood's Intake and Air/ Fuel Mixing Models

The authors Kiencke and Nielson (2000) of "Automotive Control Systems for Engine, Driveline and Vehicles" introduces their models that depend on the control objective. Kiencke and Nielson (2000) models the engine separately first with the intake manifold. Whereas Heywood describes the IC engine models from a purely physical perspective, Kiencke and Nielson (2000) approach the task of engine modeling from a control perspective, building on Heywood's models. Guzzella and Onder (2004) extended the work of Kiencke and Nielson (2000).

For idle speed control the model uses dynamic equations for the intake manifold pressure. The equation takes into account constant intake manifold volume, gas constant, ambient air temperature, specific heat ratio, mass air flow into the manifold and mass air flow into the cylinder.

The equation differs from that of Guzzella and Onder (2004) by the introduction of the specific heat ratio, and ambient air temperature instead of intake manifold temperature. The mass air flow entering the cylinder (\dot{m}_β) is not computed in real time but rather uses a look-up table $f_1(\omega_e, p_m)$. The \dot{m}_β depends on the engine speed (ω_e) and intake manifold pressure (p_m) which are measured at steady state conditions, and assume $\frac{d}{dt}\omega_e(t) = 0$ and $\frac{d}{dt}p_m(t) = 0$. The constants are then replaced by integration constant noted as $\frac{1}{\tau}$.

The same above equation is then used by the Kiencke and Nielson (2000) to arrive at \dot{m}_α . As seen in the equation

$$\dot{m}_\alpha(t) = \tau \cdot \frac{d}{dt}p_m(t) + f_1(\omega_e, p_m) \quad (2.15)$$

The air system takes into account the prediction of the amount of air entering the manifold. One method of predicting the air mass intake into the cylinder is illustrated more succinctly by Guzzella and Onder (2004). They use a model that takes into account the pressure outside and inside the intake manifold, the temperature inside the intake manifold, open area around the throttle, the gas constant for air and the discharge coefficient of the intake manifold. The equation used is for an isentropic one-dimensional compressible flow equation.

$$\dot{m}_\alpha = c_d A_\alpha(t) \frac{p_\alpha(t)}{\sqrt{R\vartheta_\alpha}} \Psi \left(\frac{p_a(t)}{p_m(t)} \right) \quad (2.16)$$

where Ψ is the flow function in Equation (2.16).

For compressible fluids it is assumed that the orifice of the pipe is isothermal, which is constant temperature. With compressible fluids there are two key assumptions that allow one to separate the flow behavior. First, no losses occur in the accelerating part of the orifice up to the narrowest point, which is the throttle valve opening. Also, the potential energy that is stored in the flow is converted isentropically in kinetic energy. Second, after passing the throttle plate all the flow is fully turbulent and the kinetic energy gained in the first assumption is dissipated into thermal energy. Therefore, no recuperation of pressure takes place (Guzzella & Onder, 2004).

Given these assumptions the pressure downstream of the narrowest point and the pressure at the narrowest point are equal. Also the temperature before and after the orifice is assumed to be the same.

The equation used to calculate the mass air flow entering the engine is derived from the thermodynamic relationships for isentropic expansion. This equation will take into account open area of throttle for a given throttle input, ambient air pressure (which is pressure up stream of throttle plate) the ambient air temperature, ideal gas constant, discharge coefficient, ratio of specific heats, and pressure downstream of throttle plate (which is considered the manifold pressure). The discharge coefficient has to be experimentally validated and is assumed constant thereafter. Other assumed constants are the gas constant, ratio of specific heats, and ambient pressure and temperature. The same equations as used by Guzzella and Onder (2004) when modeling air intake is used by Wu, Chen, and Hsieh (2007) when modeling a single-cylinder engine as seen in Equation (2.15), Equation (2.16) , Equation (3.2) and Equation (3.23). This same model was also used by Yuh-Yih Wu, Bo-Chiuan Chen, Feng-Chi Hsieh, Ming-Lung Huang and Ying-Huang Wu (2006) for modeling a 125 cc motorcycle engine, and is referred to as a filling-and-emptying model.

Another representation of the engine air delivery is the wave action charge model. This model, used by Wu, Chen, and Hsieh (2007), has the same output as the model used by Guzzella and Onder (2004) for engine systems, but uses different factors. The wave action charge model uses partial differential equations that take into account the air flow velocity (u) at a particular time (t) and position (x), the ratio of specific heats (k), the sound speed (a), the pressure (p) and cross-sectional area as seen in Equation (2.17) through Equation (2.19). Wu, Chen, and Hsieh (2007) also state that the wave action charge model can be used to study physical design of the manifold such as valve seat diameter, valve timing, pipe length and diameter, etc.

$$\frac{\partial \rho}{\partial t} + \rho \frac{\partial u}{\partial x} + u \frac{\partial \rho}{\partial x} = 0 \quad (2.17)$$

$$\frac{\partial u}{\partial t} + u \frac{\partial u}{\partial x} + \frac{1}{\rho} \frac{\partial p}{\partial x} = 0 \quad (2.18)$$

$$a^2 = \left(\frac{\partial p}{\partial \rho} \right)_s = \frac{k p}{\rho} = k R T \quad (2.19)$$

Since the mass flow of the actual air entering the cylinder of the engine cannot be measured directly it must be estimated. Different authors use different equations to calculate the air mass flow leaving the intake manifold. Guzzella and Onder (2004) use Equation (3.12) through Equation (3.16) that considers only air mass flow exiting the intake manifold. This equation cannot account for variations in fuel mass flow but makes calculations simpler. This mass flow can be calculated by assuming the engine is a volumetric pump, which is a device where in volume flow varies directly to speed. This calculation takes into account intake manifold density, volumetric efficiency, displaced volume of cylinder, and number of

revolutions per cycle. Some key assumptions are made by Guzzella and Onder (2004) in calculating the air mass flow entering the engine. They include no drop in pressure in the intake runners and the drop in temperature from the evaporation of fuel is disregarded because the heating effect of the hot intake walls, the air/fuel ratio is assumed constant and at stoichiometric value (14.7 for gasoline) for idle speed control, (and will be handled by a separate controller) and the exhaust manifold pressure maybe assumed to be constant (if not measured will have to be estimated) Guzzella and Onder (2004).

The volumetric efficiency of the engine must be calculated from experimental measurements. The volumetric efficiency approximation is a multilinear formula that is influenced by the manifold pressure and engine speed. The component dependent on the pressure must take into account compression volume, displacement volume, exhaust pressure, manifold pressure and ratio of specific heats. This portion of the volumetric efficiency describes the effects caused by the trapped exhaust gas at top dead center (TDC). The speed dependent component is a nonlinear equation that is comprised of multiple engine speed measurements and three coefficients that must be experimentally validated. Experimental validation is done using least-squares methods and measurements of manifold pressure, mass air flow and engine speed (Guzzella & Onder, 2004). Guzzella and Onder (2004) also state that evaporation of fuel can cause a change in temperature of the mixture and therefore an increase in volumetric efficiency. Alternately, Wu, Chen and Hsieh (2007) use experimental regression that considered engine speed and manifold pressure for finding volumetric efficiency.

Guzzella and Onder (2004) also give a scenario for port injection engines where mass of the fuel delivered to the cylinder can be taken into account. The fuel's temperature, specific heat

and gas constant must be known. This also assumes that the fuel has been fully evaporated and therefore the density of the air and fuel mixture must be calculated.

The filling and emptying model will be used to model the dynamics of the intake air. This model was chosen for its simplicity compared to other models that require greater knowledge of dynamic process within the intake manifold.

2.2 In-Cylinder Combustion Models

There exist several models for the combustion process within the engine producing torque. These models have evolved over the years and become simplified to be better for controls purposes. These models cover in-cylinder process and lead to estimation of torque production.

2.2.1 Thermodynamic/ In-Cylinder Combustion Models

Thermodynamic-based in-cylinder models are used to predict the engine operating characteristics, such as indicated power, mean effective pressure, specific fuel consumption, etc. This model requires many of the engine dynamics to be known, Heywood (1988) states that when “the mass transfer into and out of the cylinder during intake and exhaust, the heat transfer between the in-cylinder gases and the cylinder, piston, and cylinder liner, and rate of charge during (or energy release from the fuel) are all known, the energy and mass conservation equations permit the cylinder pressure and the work transfer to the piston to be calculated.”

The thermodynamic-based in-cylinder model follows the changing states of the thermodynamics, chemical states, and working fluid through the engine’s intake, compression, combustion, expansion, and exhaust procedures. These are referred to as the four stroke cycle. The intake and compression of the engine system is thought to be a single open system. Heywood (1988) then uses the conservation of energy and mass equation to define the model. A set of three equations is used for both intake and compression. There are three equations used for \dot{m} , \dot{q} and \dot{f} to derive mass conservation, energy conservation and fuel. The intake stroke Equation (2.20) through Equation (2.22) and three slightly different equations for these variables during the compression stroke Equation (2.23) through Equation (2.25). The six equations are then solved to find the pressure of the flow. During intake and compression the working fluid’s

composition is considered stationary. The compression and exhaust process can be calculated using Equation (2.23) through Equation (2.25) and Equation (2.26) through Equation (2.28) respectively. The thermodynamics and composition properties of the fluid can be determined with those assumptions using another set of equations. Heywood (1988) states the unsteady gas dynamic equations are more accurate to calculate the mass flow through the valve openings

Intake Equations:

$$\dot{m} = \dot{m}_i - \dot{m}_e \quad (2.20)$$

$$\dot{f} = \frac{\dot{m}_i}{m} (f_i - f) - \frac{\dot{m}_e}{m} (f_e - f) \quad (2.21)$$

$$\dot{\phi} = \frac{B}{A} \left[\frac{\dot{m}}{m} \left(1 - \frac{h}{B} \right) - \frac{\dot{V}}{V} - \frac{C}{B} \phi + \frac{1}{Bm} (\dot{m}_i h_i - \dot{m}_e h_e - \dot{Q}_w) \right] \quad (2.22)$$

Modeling of the combustion process is very complex. The simplest method, as stated by Heywood (1988), is to use a one-zone model which assures one thermodynamic system to represent the entire combustion chamber contents.

The expansion of the gases in the cylinder is treated as a continuation of the combustion process or separately after the combustion. The mass, fuel, and energy conservation equation can be used. The equations Heywood used are for one-zone open system model. This set of equations requires knowing the enthalpy of the flow. This enthalpy is admittedly hard to measure in real-time.

The working fluid state can be found around the open cycle, this is done using Equation (2.28), which is “the work transferred to the piston per cycle”. Then, using the working fluid

state, which is the work output, along with the mass of fuel and air and engine speed, characteristics of the engine such as the power, torque, mean effective pressure, specific fuel consumption etc. can be found. (J. Heywood, 1988)

Compression Equation:

$$\dot{m} = 0 \quad (2.23)$$

$$\dot{f} = 0 \quad (2.24)$$

$$\dot{\phi} = \frac{B}{A} \left[-\frac{\dot{V}}{V} - \frac{\dot{Q}_w}{Bm} \right] \quad (2.25)$$

Exhaust Equation:

$$\dot{m} = -\dot{m}_e \quad (2.26)$$

$$\dot{f} = -\frac{\dot{m}_e}{m} (f_e - f) \quad (2.27)$$

$$\dot{\phi} = \frac{B}{A} \left[-\frac{\dot{m}_e}{m} \left(1 - \frac{h}{B} \right) - \frac{\dot{V}}{V} - \frac{C}{B} \phi + \frac{1}{Bm} (-\dot{m}_e h_e - \dot{Q}_w) \right] \quad (2.28)$$

Open Cycle Equation:

$$W_c = \oint p \, dV \quad (2.29)$$

2.2.2 Spark-Ignition (SI) In-Cylinder Combustion Models

This model allows simplification of the thermodynamic model because the fuel, air, and residual gas charge is essentially uniformly premixed. For the spark ignition engine model Heywood (1988) focuses on the combustion sub-model. Modeling of the SI engine allows some assumptions for simplification to be made. Heywood states some assumptions for the SI engine, “thermodynamic modeling are: (1) the fuel, air, residual gas charge is essentially uniformly premixed; (2) the volume occupied by the reaction zone where the fuel-air oxidation process actually occurs is normally small compared with the clearance volume—the flame is a thin reaction sheet even though it becomes highly wrinkled and convoluted by the turbulent flow as it develops;” and “(3) thermodynamic analysis, the contents of the combustion chamber during combustion can be analyzed as two zones—an unburned and a burned zone.”

The spark ignition engine model can be used for engine design. The model can be used to calculate the flame geometry and predict the mass fraction burned of the fuel. Using the thermodynamic-based simulation structure, when combined with a combustion model, can predict the rate of fuel burning. The combustion model can either be empirically based, or “based on the highly wrinkled, thin reaction-sheet flame model” states Heywood (1988). The equations used in this model cannot be used for controls purposes because the equations require the measurement of in-cylinder phenomena such as the shape of the combustion cylinder, burning area, mass burning rate, etc. cannot be done in real-time. Variables such as spherical burning area and burned gas volume require must be solved using partial differential equations relative to burned gas radius.

$$V_b(r_b, r_c, \alpha_c, z_b) = V_b(p, \theta) \quad (2.30)$$

2.2.3 Fluid-Mechanic Model

The Fluid-Mechanics based models, as stated by Heywood, allow the modeling of fluids within the intake and exhaust port. The models are three-dimensional and give more detail about the working fluid in contrast to the one-dimensional models, since the flows inside the intake manifold are inherently unstable and three dimensional.

Predictions of patterns of gas-flow can be done best by comparing to fuel spray and combustion calculations. The partial differential equations that represent the conservation of mass, momentum, energy, and species concentrations are solved by engine process. Heywood states that for a computer to solve these partial differential equations the entire volume must be decomposed into multiple finite volumes.

Heywood breaks down the multidimensional engine flow model as follows: (1) the turbulence model is a mathematical model that describes the small-scale characteristics of the flow which cannot be directly calculated. (2) The differential equations are transformed using the discretization procedures into algebraic relations between discrete values of velocity, pressure, temperature, etc. (3) Then there is the solution algorithm that solves the algebraic equations. (4) Last, there is the computer code which provides an interface between input and output for information and most importantly converts numerical algorithm into computer language.

2.2.4 Extension to Heywood's In-Cylinder Combustion Models

Other authors have taken models and derived control oriented models from Heywood (1988) engine equations.

Kiencke and Nielson (2000) derive the equations for the energy conversion model and torque balance. They represent the combustion torque (T_{comb}) using a nonlinear map $f_2(\omega_e, p_m)$ which is measured at each of the engine's operating points. The dynamics of the combustion torque is linearized separately by using a first order lag $T_{l,e}$ and dead time $T_{d,e}$. The $T_{l,e}$ and $T_{d,e}$ can be approximated using Equation (2.31) and Equation (2.32) respectively.

$$T_{l,e} \approx \frac{2(CYL - 1)}{CYL} \cdot \frac{1}{\omega_e} \quad (2.31)$$

$$T_{d,e} \approx \frac{3}{4\omega_e} \quad (2.32)$$

Kiencke and Nielson then consider the torque balance at the crank shaft to be as follows:

$$2\pi\Theta_e \frac{d}{dt} \omega_e(t) = T_{comb}(t) - T_l(t) \quad (2.33)$$

They then state for an open clutch the moment of inertia can range from $\Theta_e = 0.15 \dots 0.30 \text{ kg m}^2$. Normalized variables are then placed into the equation noted by the subscript "0" in Equation (2.34).

$$2\pi \cdot \frac{\Theta_e \cdot \omega_{e,0}}{T_0} \cdot \frac{d(\omega_e/\omega_{e,0})}{dt} = \frac{T_{comb}}{T_0} - \frac{T_l}{T_0} \quad (2.34)$$

Where $\omega_{e,0}$ and T_0 are the nominal engine speed and nominal torque respectively in Equation (2.34).

2.2.4.1 Torque Production/ Combustion

Since the torque production is not measured directly it must be estimated. The torque production is nonlinear and can be comprised of many variables such as fuel mass in cylinder, air/fuel ratio, engine speed, ignition, injection timing and exhaust gas regulation. Guzzella and Onder (2004) use a Willan's approximation to describe the dynamic actions of the engine torque. For their engine torque production model they make several assumptions. They assume at constant speed the torque primarily depends on manifold pressure. "Usually thermodynamic simulations are used to predict the engine torque, but for controls those calculations are too time consuming" as stated by Guzzella and Onder (2004).

Guzzella and Onder (2004) explain there are two possible solutions to have engine torque data for controls purposes. One is to measure or calculate the engine torque for all possible operating conditions and store this data in grid form for later on-line use. The second and the more likely choice are to use physical knowledge of the system and some assumptions to predict the engine torque.

2.2.4.1.1 The Willan's Approximation:

The Willan's approximation is used to approximate an engine's torque and efficiency. This is done by splitting the problem into multiple parts. The simplification is done by thinking of the engine as a Willan's machine. The engine torque is a function of the brake mean effective pressure (p_{me}). This equation for calculation of brake mean effective pressure is normalized

formulation that takes into account displacement volume (V_d) and engine torque (T_e) as seen in Equation (2.35). Fuel mean effective pressure ($p_{m\phi}$) is also used in the calculation of engine efficiency. The fuel mean effective pressure is a function of the lower heating value (H_l) of the fuel, burnt per combustion cycle mass (m_ϕ) and volume displacement (V_d) as seen in Equation (2.36). The Willan's approximation notes that there is a simple relationship between mean fuel pressure and mean effective pressure that approximates real engine behavior very well. This approximation clearly shows the contributing factors between internal effects such as thermodynamic effects ($e(\cdot)$) and external effects such as friction and gas exchange on the engine efficiency represented by ($p_{me0}(\cdot)$). The internal effect take into account the lower heating value, air/fuel ratio (λ), displacement volume (V_d), engine speed (ω_e) and mass flow of air into the cylinder. Within the torque generation calculations there is a time delay between injection and torque center. The time delay needs to be taken into account because the torque production does not respond immediately to an increase in manifold pressure. (Guzzella & Onder, 2010)

Losses such as gas exchange (p_{me0g}) and friction losses (p_{me0f}) are also taken into account for the torque production. The loss due to gas exchange (p_{me0g}) is the cycle-average pressure difference between intake manifold pressure and exhaust manifold pressure. Equation (2.39) is the best for solving the friction losses directly by knowing the intake and exhaust pressures. Later an assumption is made that if the exhaust gas (p_3) is deposited into the atmosphere is the atmospheric pressure (p_α). Losses due to friction within the engine have been presented in many, forms the one presented in Guzzella and Onder (2004) takes into account engine speed and displaced volume. The model also uses experimental validation for some coefficients.

$$p_{me} = \frac{T_e \cdot 4\pi}{V_d} \quad (2.35)$$

$$p_{m\varphi} = \frac{H_l \cdot m_\varphi}{V_d} \quad (2.36)$$

$$p_{me} = e(m_\varphi, \omega_e, \lambda, \zeta, x_{egr}, \dots) \cdot p_{m\varphi} - p_{me0}(\omega_e, m_\beta, \vartheta_e, \dots) \quad (2.37)$$

$$p_{me0}(\omega_e, \dot{m}_\beta, \vartheta_e, \dots) = p_{mfe0}(\omega_e, \vartheta_e, \dots) + p_{me0g}(\dot{m}_\beta) \quad (2.38)$$

$$p_{me0g} = p_3 - p_2 \quad (2.39)$$

2.2.4.1.2 Other Torque Models

In contrast to other models, authors Sun, Kolmanovsky, Cook and Buckland (2005) describe the engine rotational dynamics taking into account engine brake and load torque. Brake torque is the ability of the engine to do work on the brake i.e. stator of dynamometer. The brake torque is broken down into indicated torque and total friction.

Authors Wu, Chen and Hsieh (2007) use three different models to estimate the indicated torque. The first torque-function is a simple function to estimate the indicated engine torque as seen in Equation (2.40). Where $c_{tor,i}$ is the coefficient from curve fitting of steady state experimental results and “SI is the effort of the spark advance angle on the engine torque” which is solved using Equation (2.41). Where in Equation (2.41) SI is solved as a function of new variables spark advance (SA) and minimum spark advance for best brake torque (MBT). The second is a mean-value combustion torque module that considers the first law of

thermodynamics as seen in Equation (2.42). Where W is the work output of the engine. The third is an instantaneous combustion torque model which considers the first law of thermodynamics and crank geometry as seen in Equation (2.44). Where A_p is the area of the piston, p_c is the in-cylinder pressure, p_a is the ambient air pressure, r is the radius of the crank, l is the length of the connecting rod and ϕ is the crank angle in units of radians. The work output can be solved using Equation (2.43).

Friction torque is modeled using mean-value and dynamic friction modules. The mean-value model input is the engine speed only.

The dynamic torque model takes into account the piston assembly friction and crankcase assembly friction as seen in Equation (2.44). The inputs to the dynamic torque model are the engine cylinder pressure and crank angle. (Y-Y Wu et al., 2007)

$$T_{ind} = c_{tor,1} (c_{tor,2} - c_{tor,3} P_m^{c_{tor,4}} - c_{tor,5} \omega_e^{c_{tor,6}}) m_\beta SI \quad (2.40)$$

$$SI = [c_{SI,1} \cos(SA - MBT)]^{SI,2} \quad (2.41)$$

$$T_{ind} = \frac{W}{4\pi} \quad (2.42)$$

$$\frac{dW}{d\phi} = p_c \frac{dV_{cyl}}{d\phi} \quad (2.43)$$

$$T_{ind} = (p_c - p_a) A_p r \left[\sin \phi + \frac{(l/r) \sin(2\phi)}{\sqrt{1 - (l/r)^2 \sin^2 \phi}} \right] \quad (2.44)$$

$$T_{fric} = \frac{V_d (C_1 \omega_e^2 + C_2) \sqrt{SD_{CM}/B}}{4\pi} \quad (2.45)$$

$$T_e = T_{ind} - T_{fric} - T_l = I_e(\phi) a + b \omega_e \quad (2.46)$$

Equation (2.46) the engine torque is solved as a function of the indicated torque, friction torque and engine load. The variables are a the crankshafts angular acceleration, b is the damping constant of the crankshaft bearing and non-linear rotational inertia I_e changes with the rotation and movement of the crank assembly. The rotational inertia is a function of the rotational inertia of crankshaft and connecting rod, mass of the piston and connecting rod, and the length of the connecting rod. Wu, Chen and Hsieh (2007) also use a mean-value engine model that simplifies the rotational inertia equation.

The torque equation takes into account the engines speed dynamics. This model deals with the inertia of the engine, torque production and torque load which is considered a disturbance by Guzzella and Onder (2004). The torque load in a real engine can take the form of an alternator or power steering pump.

$$\frac{d}{dt} \omega_e(t) = \frac{1}{\Theta_e} [T_e(t) - T_l(t)] \quad (2.47)$$

The previous equations will need to be linearize around an operating point. Using the equations described above or similar ones the model can be simulated in Matlab/ Simulink as noted in Herman and Franchek (2000), Guzzella and Onder (2004). Wu, Y-Y., Chen, B-C., & Hsieh, F-C. (2007) uses similar equations as Guzzella and Onder (2004). Wu, Y-Y., Chen, B-C., & Hsieh, F-C. (2007) use a detailed calculation that takes into account the variations in crank shaft and piston geometry during engine operation.

2.2.4.1.3 Other Variations

Rajamani (2006) takes two approaches to the mean-value model of SI Engines. The first uses parametric equations for the model and the second uses look-up tables with equations. The focus of the model for a SI engine is the air flow model for the intake manifold and the rotational dynamics of the crankshaft. Rajamani (2006) start off with the engine rotational dynamics. The dynamics of the engine rotational moment of inertia, engine speed dynamics, indicated combustion torque, external load torque and pumping and frictional torque are lumped as one term.

For the indicated torque the authors use an equation from authors Hendricks and Sorenson. The indicated torque is a function of the fuel energy constant, thermal efficiency multiplier that accounts for the cooling and exhaust system losses, and the fuel mass flow rate into the cylinder is a value in the Equation (2.48). (Rajamani, 2006)

$$T_{ind} = \frac{H_u \eta_i \dot{m}_f}{\omega_e} \quad (2.48)$$

The indicated and friction torque varies as the engine proceeds through cycles. Rajamani (2006) also states that the dynamics of rotation are averaged with a mean value model.

The hydrodynamic and pumping friction losses are found using Equation (2.49) through Equation (2.51). Both equations are polynomials with the hydrodynamic friction losses being a function of engine speed which is taken from Heywood (1988). The pumping friction loss is a function of engine speed and manifold pressure which is taken from Hendricks and Sorenson (1990).

$$F_{loss} = a_0\omega_e^2 + a_1\omega_e + a_2 \quad (2.49)$$

$$P_{loss} = b_0\omega_e \cdot p_{man} + b_1p_{man} \quad (2.50)$$

$$T_f = a_0\omega_e^2 + a_1\omega_e + a_2 + b_0\omega_e \cdot p_{man} + b_1p_{man} \quad (2.51)$$

The manifold pressure equations are the same as used by Guzzella and Onder (2004). The mass air flow going into the cylinder is as in Guzzella and Onder (2004). The only unknown aspect is the volumetric efficiency, which Rajamani (2006) does not detail with the simple mean-value engine model. The model for the intake into the intake manifold is similar to Guzzella and Onder (2004).

Rajamani (2006) also details an engine model that includes look-up maps. Many of the previously mentioned functions such as indicated torque, total friction and pumping loss, mass air flow into the intake manifold and mass air flow into the cylinder are found using a dynamometer. The look-up maps can be presented in tabular form or plotted data. These models that use look-up tables are considered second order engine models because each function has two dependent variables. (Rajamani, 2006)

CHAPTER 3

ENGINE MODELING

The initial intention of this research was to study, investigate and ultimately create a model that represent a single cylinder engine, starting with studying “Introduction to Modeling and Control of Internal Combustion Engine Systems” written by Guzzella and Onder (2004), which covers the creation of engine models for gasoline and diesel engines. The focus of this thesis was to study port-injection gasoline engines. Within the text by Guzzella and Onder (2004) the engine is broken down into sections in order to simplify the calculations.

The initial modeling attempt was to create an idle speed controller. This model was to be created in order to simulate an engine running under idle conditions. This requires an understanding of the various systems within an engine and the assumptions needed when creating a control oriented model (COM). The sections are broken down into the air system which includes throttle plate nonlinearities, mass air flow through throttle, and air mass flow into engine cylinder and intake manifold pressure dynamics. Second is the mechanical system which governs the mechanical output after engine combustion this includes the dynamics engine speed, torque production and simulation of engine load.

3.1 Intake Manifold Dynamics

The intake manifold of an engine is modeled as a receiver as stated by Guzzella and Onder (2004). Thus this receiver is considered a fix volume and therefore the thermodynamic states are considered to be constant.

The engines air system is comprised of the fluid dynamics of the air charge from the beginning of the intake manifold to air flow around the throttle and mass air flow or air and fuel mixture entering the manifold. Also, since a lot of the various changes taking place inside the

engine manifold cannot always be measured with every engine cycle, certain assumptions must be made. The air mass entering the manifold can be estimated by Equation (2.16) repeated here.

For compressible fluids i.e. air, it's assumed that the orifice of the pipe is isothermal, which is constant temperature. With compressible fluids there are two key assumptions that allow you to separate the flow behavior. First, no losses occur in the accelerating part of the orifice up to the narrowest point which is the throttle valve opening. Also the potential energy that is stored in the flow is converted isentropically in kinetic energy. Second, after passing the throttle plate all the flow is fully turbulent and the kinetic energy gained in the first assumption is dissipated into thermal energy. Therefore no recuperation of pressure takes place (Guzzella & Onder, 2004).

Given these assumptions the pressure downstream of the narrowest point and the pressure at the narrowest point are equal.

$$\dot{m}_\alpha = c_d A_\alpha(t) \frac{p_\alpha(t)}{\sqrt{R\vartheta_\alpha}} \Psi \left(\frac{p_\alpha(t)}{p_m(t)} \right) \quad (2.16)$$

where \dot{m}_α is the mass air flow entering the manifold in kilograms per second, c_d is the dimensionless discharge coefficient of the intake manifold, A_α is the open area of the throttle in m^2 , ϑ_α is the temperature in the intake manifold in Kelvin, p_α is the atmospheric pressure upstream of the intake manifold in dimensions of Pascal, R is the gas constant for air in Joules per kilogram Kelvin, p_m is the manifold pressure in Pascal, and $\Psi \left(\frac{p_\alpha(t)}{p_m(t)} \right)$ is the flow function defined in Equation (3.1).

$$\Psi\left(\frac{p_a(t)}{p_m(t)}\right) = \begin{cases} \sqrt{k \left[\frac{2}{k+1}\right]^{\frac{k+1}{k-1}}} \text{ for } \frac{p_m(t)}{p_a(t)} < \left[\frac{2}{k+1}\right]^{\frac{k}{k-1}} \\ \left[\frac{p_a(t)}{p_m(t)}\right]^{1/k} \cdot \sqrt{\frac{2k}{k-1} \cdot \left[1 - \frac{p_m(t)}{p_a(t)}\right]^{\frac{k-1}{k}}} \text{ for } \frac{p_m(t)}{p_a(t)} \geq \left[\frac{2}{k+1}\right]^{\frac{k}{k-1}} \end{cases} \quad (3.1)$$

where the new constant k is the isentropic exponent. Guzzella and Onder (2004) make the assumption for simplification that $k \approx 1.4$ for working fluids such as intake air and exhaust gas at lower temperatures, and is the ratio of specific heat. The discharge coefficient c_d is assumed to be 1 for simplification and is the most ideal case. Equation (2.16) and Equation (3.1) become as seen in Equation (3.2) and Equation (3.3).

$$\dot{m}_\alpha(t) = A_\alpha(t) \frac{p_\alpha}{\sqrt{R\vartheta_\alpha}} \frac{1}{\sqrt{2}} \text{ for } \frac{p_m(t)}{p_a} < \frac{1}{2} \quad (3.2)$$

$$\dot{m}_\alpha(t) = A_\alpha(t) \frac{p_\alpha}{\sqrt{R\vartheta_\alpha}} \sqrt{2 \frac{p_m(t)}{p_\alpha} \left[1 - \frac{p_m(t)}{p_\alpha}\right]} \text{ for } \frac{p_m(t)}{p_a} \geq \frac{1}{2} \quad (3.3)$$

Since the p_m and p_α can be measured in real-time the ratio $\frac{p_m(t)}{p_a}$ can be measured.

Therefore the controller is able to switch between the predictions of $\dot{m}_\alpha(t)$ in real time.

The area around the throttle A_α is considered nonlinear and is described by the Equation (3.4) and Equation (3.5).

$$\alpha_{th} = \alpha_{th,0} + \left(\frac{\pi}{2} - \alpha_{th,0}\right) \cdot u_{\alpha} \quad (3.4)$$

$$A_{\alpha}(\alpha_{th}) = \frac{\pi d_{th}^2}{4} \cdot \left(1 - \frac{\cos \alpha_{th}}{\cos \alpha_{th,0}}\right) + A_{th,leak} \quad (3.5)$$

where α_{th} is the angle of the throttle in units of degrees, $\alpha_{th,0}$ is the angle of the throttle when closed fully in the units of degrees, u_{α} is the control signal input between 0% and 100%, $A_{th,leak}$ is the area of the throttle when α_{th} and $\alpha_{th,0}$ are equal in units of m^2 , d_{th} is the diameter in meters that becomes nonlinear.

To increase the accuracy of predictions of manifold pressure entering the intake manifold \dot{m}_{α} an adjustment can be made to the nonlinear d_{th} . This is performed by predicting \dot{m}_{α} from known user selected throttle angle that will vary with each prediction and therefore will change with each measurement.

For all operation conditions of the engine in idle speed control, the manifold pressure is considered to be below 0.5 bars (50,000 Pascal). This assumption simplifies the calculations and allows for the nonlinear function Ψ to be constant. The diameter of the throttle d_{th} enters in a nonlinear way as seen in Equation (3.6) a substitution must be made to form a linear in the parameters problem. This substitution can be seen in the equation below

$$\delta = \frac{\pi \cdot d_{th}^2}{4} \quad (3.6)$$

$$\tilde{y}_\alpha = \begin{bmatrix} \dot{\tilde{m}}_{\alpha,1} \\ \dot{\tilde{m}}_{\alpha,2} \\ \dots \\ \dot{\tilde{m}}_{\alpha,N} \end{bmatrix} \in \mathfrak{R}^{N \times 1}, M_\alpha = k_\alpha \cdot \begin{bmatrix} 1 & 1 - \frac{\cos \alpha_{th}}{\cos \alpha_{th0,1}} \\ 1 & 1 - \frac{\cos \alpha_{th}}{\cos \alpha_{th0,2}} \\ \dots & \dots \\ 1 & 1 - \frac{\cos \alpha_{th}}{\cos \alpha_{th0,N}} \end{bmatrix} \in \mathfrak{R}^{N \times 2} \quad (3.7)$$

Equation (3.7) shows a vector \tilde{y}_α which is the predicted mass air flow entering the manifold, M_α is a matrix of two columns derived from Equation (3.2) to Equation (3.7). Where the gain k_α is $k_\alpha = \frac{p_\alpha}{\sqrt{R\theta_\alpha}} \frac{1}{\sqrt{2}}$ as from Equation (3.2) and Equation (3.3), $\dot{\tilde{m}}_{\alpha,N}$ is the n-th prediction of the intake manifold mass air flow entering the manifold, δ is the nonlinear correction factor. The full column rank of M_α from the experimental data used to determine the coefficients is rank of 2.

The system shown in Equation (2.16) and Equation (3.1) through Equation (3.5) with Equation (3.6) and Equation (3.7) can be rewritten as seen in Equation (3.8).

$$\tilde{y}_\alpha = M_\alpha \cdot [A_{th,leak}, \delta]^T \quad (3.8)$$

The solution of equation $[A_{th,leak}, \delta]^T$ that minimizes error is shown in Equation (3.9).

$$E_{LS} = \sum_{i=1}^N (\dot{m}_{\alpha,i} - \dot{\tilde{m}}_{\alpha,i})^2 \quad (3.9)$$

Then using Equation (3.10) below δ can be found.

$$[A_{th,leak}, \delta]^T = [M_\alpha^T \cdot M_\alpha]^{-1} \cdot M_\alpha^T \cdot \tilde{y}_\alpha \quad (3.10)$$

Using the δ value found in Equation (3.10) the appropriate d_{th} can be found using Equation

(3.11)

$$d_{th} = \sqrt{\frac{\delta}{\pi}} \quad (3.11)$$

The d_{th} found using Equation (3.11) will then be used for real time predictions of \dot{m}_α with an acceptable amount of error.

3.2 Engine Air Mass Flow

The engine is considered a volumetric pump when modeling the air mass charge entering the engine cylinder. Therefore the air volume flow is approximately proportional to the engine speed. The air mass flow entering the cylinder is described using a set of nonlinear equations. Equation (3.12) through Equation (3.16) describe the engine air mass flow entering the engine cylinder.

$$\dot{m}_e(t) = \frac{p_m(t)}{R\vartheta_m(t)} \cdot \lambda_l(\omega_e(t), p_m(t)) \cdot \frac{V_d}{N} \cdot \frac{\omega_e(t)}{2\pi} \quad (3.12)$$

Where Equation (3.12) describes the mass of the mixture of fuel and air entering the cylinder; where $\lambda_l(\omega_e(t), p_m(t))$ is the volumetric efficiency, N is the number of revolutions per cycle, which N=2 for a four stroke engine, ϑ_m is the temperature of the intake manifold in Kelvin and V_d is the displacement volume of the cylinder.

$$\lambda_l(\omega_e(t), p_m(t)) = \lambda_{l\omega}(\omega_e(t)) \cdot \lambda_{lp}(p_m(t)) \quad (3.13)$$

Describes the volumetric efficiency and is broken down into its engine speed dependent part in Equation (3.14) and its manifold pressure dependent part in Equation (3.15).

$$\lambda_{l\omega}(\omega_e(t)) = \gamma_0 + \gamma_1 \cdot \omega_e + \gamma_2 \cdot \omega_e^2 \quad (3.14)$$

Equation (3.14) is a polynomial that depends on speed only as the dynamic variable to solve for the volumetric efficiency.

$$\lambda_{lp}(p_m(t)) = \frac{V_c + V_d}{V_d} - \frac{V_c}{V_d} \cdot \left(\frac{p_e}{p_m(t)} \right)^{1/k} \quad (3.15)$$

Equation (3.15) describes the manifold pressure dependant section of the volumetric efficiency. With p_e as the exhaust manifold pressure and considered a constant.

$$\dot{m}_\beta(t) = \frac{\dot{m}_e(t)}{1 + \frac{1}{\lambda\sigma_0}} \quad (3.16)$$

Finally the mass air flow exiting the manifold is described by Equation (3.16) where λ the air / fuel ratio is assumed to be 1 and σ_0 is the stoichiometric air to fuel ratio assumed to be 14.7 for gasoline engine at ideal. While for E85 the stoichiometric is 9.9.(Grabner, Eichlseder, & Eckhard, 2010), (Varde & Manoharan, 2009)

Coefficients γ_0 , γ_1 and γ_2 from Equation (3.17) can be solved experimentally using measurements of engine speed $\omega_e(t)$, manifold pressure $p_m(t)$ and intake air mass flow $\dot{m}_\alpha(t)$. Knowing these measurements the volumetric efficiency can be written as seen in Equation (3.18).

$$\gamma_0 + \gamma_1 \cdot \omega_{e,i} + \gamma_2 \cdot \omega_{e,i}^2 = \Psi(\omega_{e,i}, p_{m,i}, \dot{m}_{\alpha,i}) \quad (3.17)$$

The right side of Equation (3.17) is then solved as seen in Equation (3.18).

$$\psi(\omega_{e,i}, p_{m,i}, \dot{m}_{\alpha,i}) = \frac{R \vartheta_m(t)}{p_{m,i}} \cdot \left(\frac{V_c + V_d}{V_c} - \frac{V_c}{V_d} \left(\frac{p_{\alpha}}{p_{m,i}} \right)^{1/k} \right)^{-1} \cdot \dot{m}_{\alpha,i} \cdot \left(\frac{1 + \sigma_0}{\sigma_0} \right) \cdot \frac{4\pi}{\omega_{e,i} V_d} \quad (3.18)$$

As was previously done with Equation (3.6) through Equation (3.11) the coefficients of the volumetric efficiency can be solved using Equation (3.18) and Equation (3.19). The full column rank of M_{η} from the experimental data used to determine the coefficients is rank of 3.

$$\tilde{y}_{\eta} = \begin{bmatrix} \psi_1 \\ \psi_2 \\ \dots \\ \psi_N \end{bmatrix} \in \mathfrak{R}^{N \times 1}, M_{\eta} = \begin{bmatrix} 1 & \omega_{e,1} & \omega_{e,1}^2 \\ 1 & \omega_{e,2} & \omega_{e,2}^2 \\ \dots & \dots & \dots \\ 1 & \omega_{e,N} & \omega_{e,N}^2 \end{bmatrix} \in \mathfrak{R}^{N \times 3} \quad (3.19)$$

$$[\gamma_0, \gamma_1, \gamma_2]^T = [M_{\eta}^T \cdot M_{\eta}]^{-1} \cdot M_{\eta}^T \cdot \tilde{y}_{\eta} \quad (3.20)$$

The predicted versus the measured engine speed error is found using Equation (3.22).

$$E = \sum_{i=1}^N [(\omega_{e,i} - \tilde{\omega}_{e,i})^2] \quad (3.22)$$

The algebraic result of Equation (3.22) ideal to be as small as possible.

$$\frac{d}{dt} p(t) = \frac{k \cdot R}{V_m} \cdot [\dot{m}_{\alpha}(t) \cdot \vartheta_{in}(t) - \dot{m}_{\beta}(t) \cdot \vartheta(t)] \quad (3.23)$$

$$\frac{d}{dt} \vartheta(t) = \frac{R \cdot \vartheta_m}{p \cdot V_{m \cdot c_v}} \cdot [c_p \cdot \dot{m}_{\alpha}(t) \cdot \vartheta_{in} - c_p \cdot \dot{m}_{\beta}(t) \cdot \vartheta - c_v \cdot (\dot{m}_{\alpha}(t) - \dot{m}_{\beta}(t)) \cdot \vartheta] \quad (3.24)$$

An adiabatic formulation as seen in Equation (3.26) is considered a very good approximation of the receiver's behavior. The dynamics of the intake manifold are described by a lumped parameter model under isothermal conditions. Where the volume is constant.

$$\frac{d}{dt}p_m(t) = \frac{R \cdot \vartheta_m}{V_m} \cdot [\dot{m}_\alpha(t) - \dot{m}_\beta(t)] \quad (3.25)$$

$$\vartheta_m(t) = \vartheta_{in}(t) \quad (3.26)$$

The purpose of the engine is to produce torque. Torque generation is defined as the mean value torque which is a nonlinear function defined in Equation (3.27). The mean value engine torque is a function of as stated by Guzzella and Onder (2010)“fuel mass cylinder, air/ fuel ratio, engine speed, ignition or injection timing, EGR rate etc.”

$$T_e = f(\dot{m}_\varphi, \lambda, \omega_e, \zeta, x_{egr}, \dots) \quad (3.27)$$

To correctly predict the engines torque output detailed thermodynamics simulations are needed. Thermodynamics simulations are impractical for engine control in real time because of their time consuming nature. Using knowledge from the engines physical properties Guzzella and Onder (2004) states “use some physical insight to separate the different influencing variables and to divide the modeling task into several low-dimensional problems.”

The torque generation of the engine is simplified as a Willan's machine. The Willan's approximation is done to simplify an engine's torque and efficiency characteristics. This

approximation also details the difference between the effects of internal and external factors on engine efficiency. The engine's torque and efficiency characteristics are shown in Equation (3.28) through Equation (3.31).

$$T_e(t) = (e \cdot p_{m\phi} - p_{meof} - p_{meog}) \cdot \frac{V_d}{4\pi} \quad (3.28)$$

where $e \cdot p_{m\phi}$ is the thermodynamics properties of the engine and p_{meof} and p_{meog} represent the friction and gas exchange losses respectively. The cycle-averaged pressure difference p_{meog} is between the intakes and exhaust ports of the engine and directly defined in Equation (3.31).

$$e \cdot p_{m\phi} = (\eta_0 + \eta_1 \cdot \omega_e) \cdot H_l \cdot \frac{\dot{m}_\beta(t - \tau_{inj \rightarrow TC}) \cdot 4\pi}{\lambda \cdot \sigma_0 \cdot \omega_e(t - \tau_{inj \rightarrow TC}) \cdot V_d} \quad (3.29)$$

$$p_{meof} = (\beta_0 + \beta_2 \cdot \omega_e^2) \cdot \frac{4\pi}{V_d} \quad (3.30)$$

$$p_{meog} = p_{exhaust} - p_m \quad (3.31)$$

Where η_0 , η_1 , β_0 , and β_2 are Willan's parameters, $\tau_{inj \rightarrow TC}$ is the induction to power stroke delay which is considered a transportation delay, λ is the lambda value and σ_0 is the stoichiometric constant. The Willan's parameters are found experimentally under steady state conditions. Induction to power stroke delay has to be determined. The stoichiometric constant is found using the equation below.

$$\sigma_0 = 137 \frac{b + \frac{a}{4}}{12 * b + a} \quad (3.32)$$

Where for hydrogen based fuel b is for carbon atoms and a is for hydrogen atoms. The change in engine speed with respect to time is a level variable as shown in Equation (3.33).

$$\frac{d}{dt} \omega_e(t) = \frac{1}{\Theta_e} [T_e(t) - T_l(t)] \quad (3.33)$$

Using the above equations that represent the engines dynamics a model was to be created under certain conditions. This model was intended to represent the engine dynamics under idle conditions to be later linked with a controller. Within the next section the process of measuring and determining the constants necessary to fully describe the state space model will be detailed.

CHAPTER 4

METHODOLOGY

Most of the control models mentioned in Chapter 3 depend on a set of measured variables. Therefore it's necessary to characterize the engine to be controlled by measuring variables such as engine speed, crank angle, intake manifold pressure, intake mass air flow, air/fuel ratio, intake air temperature, ignition signal and injection signal.

The test engine is set up on table. The engine is hooked to a hydraulic dynamometer at the motors shafts that produces a disturbance on the engine. This disturbance simulates real world disturbance such as heavy grass for testing purposes.

Bore	93.99 mm
Stroke	77.77 mm
Displacement	540 cc

Table 4.1: Test Engine Characteristics

4.1 LabView for Data Acquisition

To acquire the signals produced by the engine a data acquisition system had to be researched and implemented within the Georgia Southern's Renewable Energy Laboratory. This software and hardware combination must record the changing dynamics of the engine. The engine is expected to be operated at a maximum of 3000 rpms. This is one of the engine's many dynamics that created a challenge for the research. The first attempt used a well-known software package known as Lab View from National Instruments (www.ni.com). The initial data acquisition hardware setup was comprised of an Intel Pentium 4 desktop computer with data

acquisition cards that will be described throughout sections of this paper. A diagram of this system with the many connections can be seen in Figure 4.1.

In order to ensure this software will be able to keep track of the changing engine system dynamics in real time simple tests needed to be performed to measure this accuracy, without running the engine and using up fuel. It was chosen to substitute electric motors and function generators to initially test the LabView response.

Measurement Computing Inc. (www.mccdaq.com) provided the data acquisition hardware which connects sensors and instruments to the PCI communications backplane of a personal computer. Measurement Computing also provided software drivers to move measured data into LabView database. National Instruments measurement hardware was not sufficiently fast to provide the speed of data acquisition required. Within Table 4.2 the types of measurements needed, the sensors used to take those measurements and the expected maximum frequency of change is shown.

Sensor Number	Measurement	Sensor	Frequency of Measurement (Hz)
1	Engine Crank Angle and Engine Speed	Rotary Encoder	100K (electrical)
2	Throttle Angle	Potentiometer	100
3	Intake Air Temperature	Thermal Couple Type: K	0.25
4	Exhaust Air Temperature	Thermal Couple Type: K	0.25
5	Injector Timing	Injector	200K
6	Intake Mass Air Flow	Laminar Flow System	30
7	Ignition Timing	Inductive Clamp	200K

Table 4.2: List of Sensors, Measured Variables and Expected Maximum Frequency of Change

DAQ Assistant is a tool implemented within LabView by the software creators National Instruments. DAQ Assistant is made to work easily with National Instruments data acquisition hardware and includes a nice user friendly graphical user interface (GUI). To program LabView for data acquisition required the use of Measurement Computing Boards drivers. Therefore the usual means of using LabView's easily and familiar DAQ Assistant was not available and the Measurement Computing boards would not even show up in DAQ Assistant. Therefore implementing the new Measurement Computing hardware system presented a challenge when trying to record data.

Measurement Computing Universal Libraries adds additional set of VIs (virtual instruments) to LabView. The VI is LabView's program file type. A LabView VI is represented by an icon which is moveable blocks used as the user level programming language to provide an interface with data acquisition hardware.

A second piece of software called InstaCal is necessary for the interface between LabView and Measurement Computing data acquisition hardware. This software creates a configuration file that lists details about the installed Measurement Computing data acquisition boards. InstaCal also allows the data acquisition cards to be tested for proper operation.

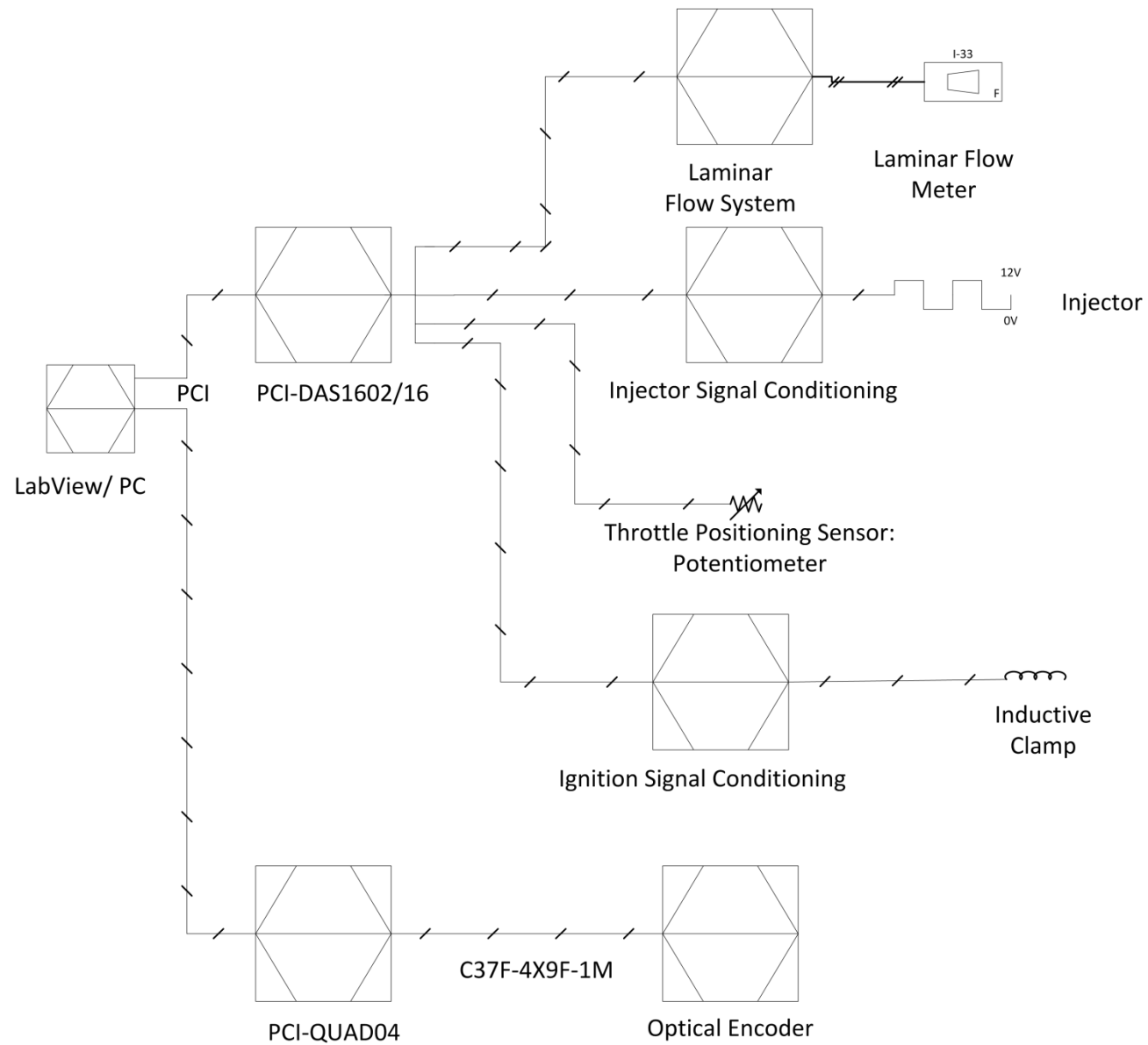

Figure 4.1: Diagram for Hardware Setup with LabView

4.1.1 LabView Limit Testing

4.1.1.1 Sine Wave

The first attempt at testing the limits of LabView was to use a function generator. The function generator is used to input a sine wave at known frequency to see if the signal could be recorded accurately. The signal was taken using Measurement Computing's PCI-DAS1602/16. This data acquisition card is able to sample signals at 200 kHz. An example provided by Measurement Computing is seen in Figure 4.2. The example allows a range of signals to be scanned, number of analog samples to collect, and sample rate in scans per second.

LabView uses many different data types. The different data types are designated by the color of the lines that connect the virtual instruments. The blue lines on the top left side of Figure 4.2 coming from inputs such as *Count*, *LowChan*, *HighChan*, *BoardNum*, *Rate*, and *Range* are 32-bit integer data, which are inputs into *AInScBg*. While the green *Cont/Sngl* is a Boolean data type that which is an input into *AInScBg*.

The new virtual instruments (VI) incorporated by Measurement Computing in Figure 4.2 include *AInScBg*, *GetStatus*, *ToEng*, *OptAIn*, *StopBg*, and *ErrMsg*. The inputs are first taken as shown on the Front Panel as seen in Figure 4.3. The *AInScBg*, located in the middle left side, has many inputs and outputs and is the main VI that defines the A/D data transfer for the background operation. *BoardNum* which designates the board number as appointed in *InstaCal* is set. The setting for *LowChan* and *HighChan* are set which designates which channels the program looks for analog signals. The *Count* designates the number of samples taken for the analog to digital conversion. The *Rate* designates the desired rate of scanning which is an input. The *Range* designates the expected voltage level of the incoming signal. The option *Continuous* if set to true the program runs in a never ending loop, else if false the program stops after the maximum

designated counts is reached as set in the *Count* argument. *InterChannel Delay* is used to specify the time between scanning individual channels. Outputs of the block are either passed on to other VIs or their individual status is displayed on the frontpanel. The *Actual Rate* of scanning shows the real rate of scanning. The main output of the *AInScBg* is the *Context*, which carries the data from a background process. Last, the error code is handling by the *ErrCode* output. The *AInScBg* outputs are then taken in by other various VIs. The *Options*, located at the bottom left, allows the method of trigger and transfer to be designated. The default option is *DEFAULTIO* this option is the easiest and chooses the best sampling mode defined by the type of DAQ board used.

The *Context* output goes to the *GetStatus* virtual instrument in bottom right of Figure 4.2. The *GetStatus* outputs the status of the background process controlled by *AInScBg*. Other outputs include the *CurCount* which is the current accumulated number of samples taken and is displayed on the front panel. The *DataArray* is output to the Front Panel and into the *ToEng* VI. The *Context* is sent to the *StopBg* for controlling the background process. Overall program is kept running using the *Running* output, which is a Boolean true or false. *Running* is then ANDed with a true false input located on the front panel in series with a not. This logic will then be if the stop is pressed and the *Running* is true the program stops. If the *Running* is true and the stop has not been pressed the process continues to run.

The output of the *ToEng* VI is the voltage value as being read by the data acquisition card. Inputs of *Range* and *BoardNum* input from the front panel and *DataArray* from the *GetStatus* are taken into the VI.

The *ErrMsg* VI takes the error Code designated by *ErrCode* which is an integer 32-bit data type. The error code is then interpreted and displayed on the Front Panel through the *ErrMsg* output as plain text.

Where the main VI *AInScBg* is used to scan analog input channels in the back ground and exports the results to the *GetStatus*. The accumulated count gets displayed on the front panel out of the *GetStatus* VI.

An analog signal was input in the data acquisition card using a differential wiring setup to minimize interference. The sine wave data was outputted to an Excel readable file to better observe what was recorded and insure that data could be recorded. The first attempts seemed to acquire a signal accurately. Further testing using the data acquisition system needed to be performed using sensors that would be used on the engine.

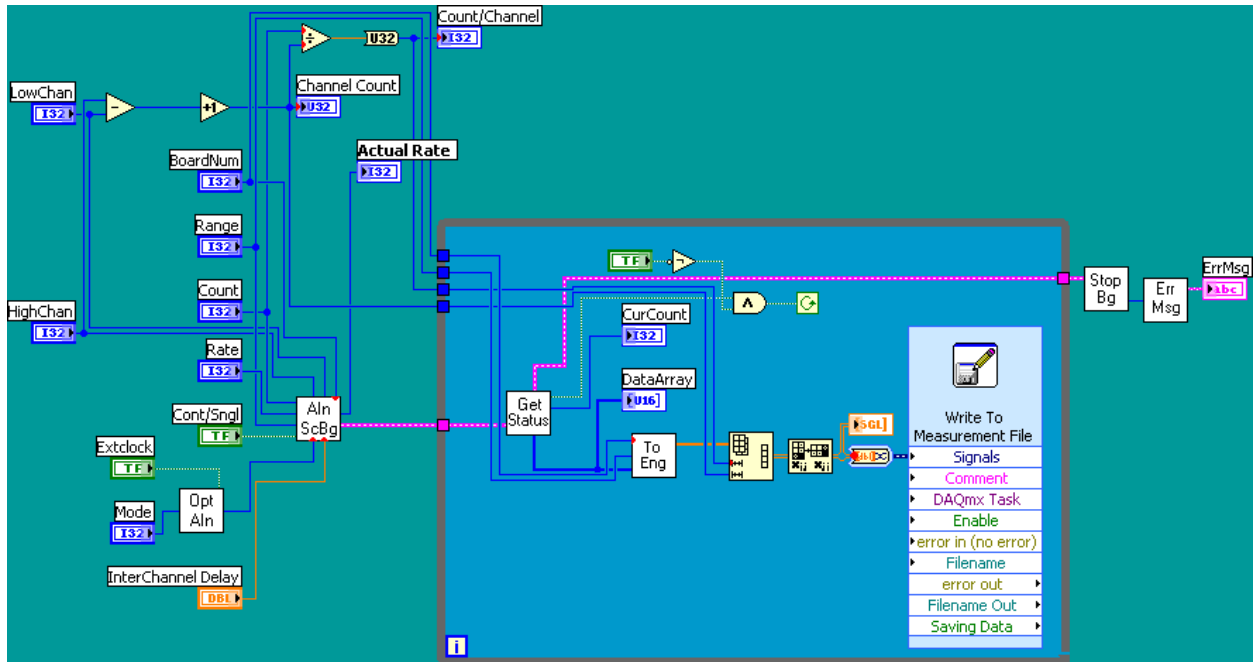

Figure 4.2: Screen of LabView Program for Analog Input

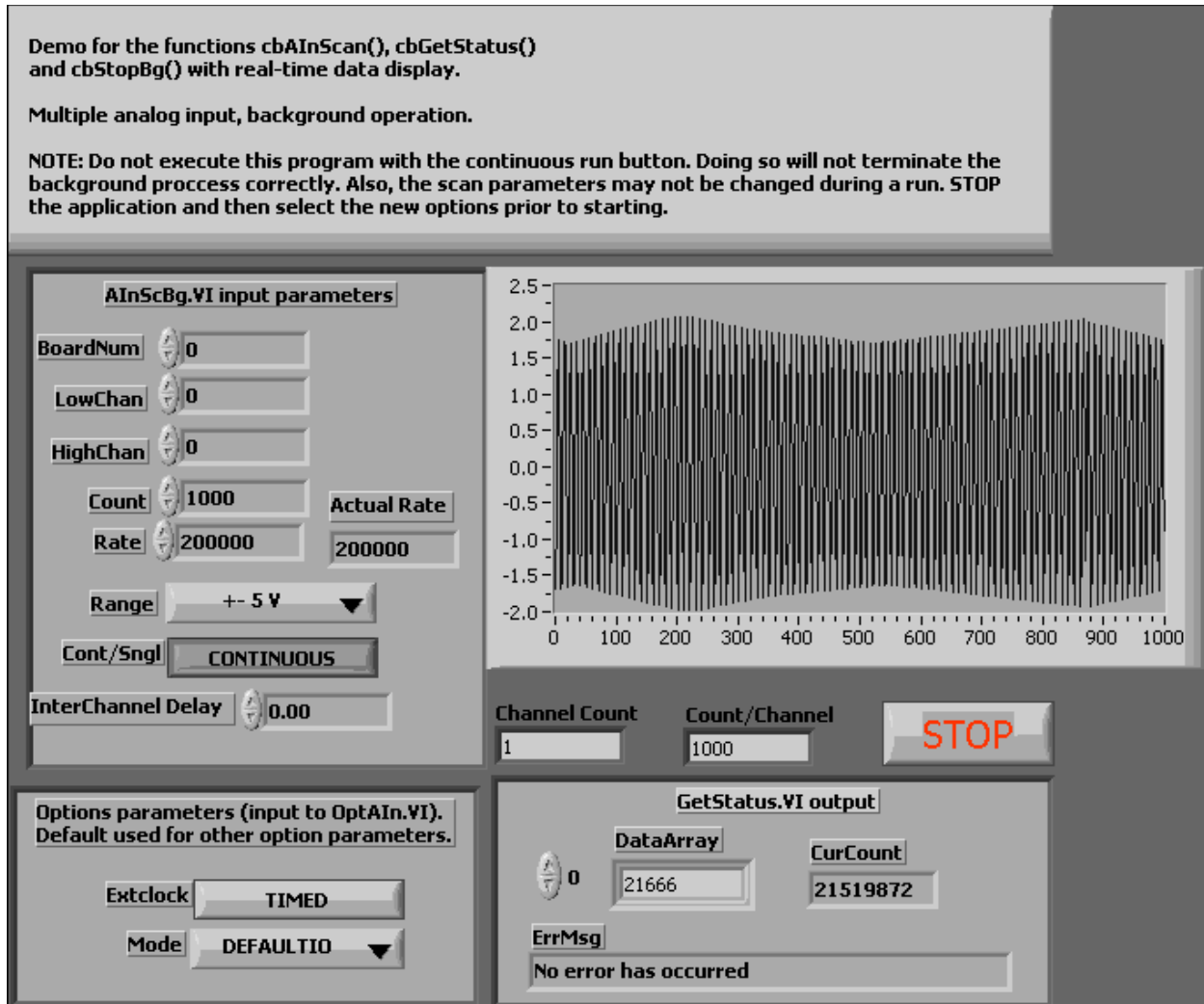

Figure 4.3: Front Panel of LabView Analog Input Program

4.1.1.2 Quadrature Encoder

The quadrature encoder signal is produced by Omron rotary encoders (E6CZ-CWZ3E). The encoder produces a signal that is a pulse train with on and off states. The three pulse trains are called channels. The first two channels, usually noted as channels A and B, are comprised of 2000 pulses for the rotary encoder used within this experiment. Channels A and B are identical in every way but are aligned out of phase by 90 degrees. The two channels with their phase shift create the encoders quadrature signal because of the four possible states of the signal produced. The quadrature signal also allows the direction of the encoder rotation to be discerned. The third

channel is usually designated the Z channel or Index. The Z channel is used to give an absolute starting position for the encoder and does this by generating one pulse per revolution. The Z channel is used to reset the encoder counts in data acquisition and to sync the encoder with top dead center (TDC) of the engine. With an encoder of such precision the encoder is able to have an accuracy of 0.18 degrees per pulse. At the expected maximum speed of the engine the encoder will be able to produce a signal with a frequency of 100 kHz.

4.1.1.3 Encoder Signal

To record the encoder's pulse and therefore discern the engine speed and crank angle the encoder signal is captured by the quadrature encoder card (PCI-QUAD04) input card. This card is able to take the pulse train produced by the rotary encoder and at a clock frequency of 1.2 MHz maximum. This translates into 36,000 revolutions per minute (rpm) using the 2000 pulses per revolution encoder, which is faster than the engine will ever operate.

$$1.2\text{MHz} = 1.2 * 10^6 \frac{\text{pulses}}{\text{second}} * \frac{\text{revolution}}{2000 \text{ pulses}} * \frac{60 \text{ seconds}}{1 \text{ minute}} = 36,000 \frac{\text{revolutions}}{\text{minutes}} \quad (4.1)$$

The encoder card keeps track of the count and outputs the number of counts to the data acquisition computer. The card is only required to keep up with no more than the maximum expected encoder count of 500 pulses per revolution, after dividing.

4.1.1.4 LabView with Rotary Encoder

The LabView code example given by Measurement Computing for use with LabView and the PCI-QUAD04 data acquisition card was the starting point of data acquisition. The example uses modules specific to the counter IC on the PCI-QUAD04. The PCI-QUAD04 uses

a LS7266R1, which is a 24-bit dual axis quadrature counter. The LS7266R1 and LabView interface for the chip gives many options for use with encoders.

The setting for the desired operation with the Omron rotary encoders (E6CZ-CWZ3E) are shown in Table 4.3 below. These settings include specifying the board number (*BoardNum*), counter number (*CounterNum*), the quadrature mode, counting mode (*CountingMode*), data encoding type (*DataEncoding*), index mode (*IndexMode*), inverting of index signal (*InvertIndex*), flag pin setting (*FlagPins*), gating and finally Load Value.

The code used is once again the block programming language as discussed in the previous section. The code used can be seen in Figure 4.4 through Figure 4.6. The program takes the inputs as mentioned in the previous paragraph and uses them to configure the chip used in the PCI-QUAD04. The program uses multiple frames that give a sequential order to progress. The first VI is the *C7266Config* which configures the 7266 chip to gather data and is located in the first frame designated frame 0 as seen in Figure 4.4. Every setting as mentioned above is an input into the *C7266Config*. The only output of the *C7266Config* is the error code that goes into the *ErrMsg* VI. The *ErrMsg* VI then outputs an error message to the Front Panel if an error occurs. On the second frame, marked as 1 at the top of the frame contains *Cload32* and *ErrMsg* VI with an output that displays the error message on the Front Panel as seen below in Figure 4.5.

For the third and last frame marked as 2 on the top of the frame as seen in Figure 4.6. Within the final frame the results as the program runs are displayed onto the Front Panel. The final frame contains the VIs *CIn32* and *CStatus* as the main VIs. Where the *CIn32* outputs a 32-bit integer after reading the current count. This VI takes the *BoardNum* and *CounterNum* as inputs and also outputs an *ErrCode*. The *ErrCode* is then output to an *ErrMsg* VI. The *CStatus* VI used in this portion of the program to interpret the status of the encoder card and the signal

being recorded. The CStatus outputs a signal that is in matrix form and is split for each using an Index Array. The split data type are Boolean and as follows, the Underflow, Overflow, Compare, Sign, Valid Index, Up(on)/Down (off), and Error. The Underflow is displayed as true when the count goes down below zero and Overflow is set to true when the count goes over the maximum limit. The Compare becomes true when the preset register is equal to the current count. The Error is set to true when an error occurs due to unwarranted noise. With all three being reset when the CStatus is called upon. The Sign is set to true when the MSB (most significant bit) is 1 and false when the MSB of the count is 0. Valid Index is set to true when the index signal passes and is reset after it passes. The Up/Down is true when the current count is incremented and is false when the count decrements.

Setting	Setting Value
Board number	2
Counter number	1
Quadrature mode	X1_QUAD
Counting mode	NORMAL_MODE
Data encoding type	BINARY_ENCODING
Index mode	RESET_CTR
Inverting of index signal	ENABLED
Flag pin setting	CARRY_BORROW
Gating	DISABLED
Load Value	0

Table 4.3: LabView Settings for Quadrature Encoder Card

There are many setting that need to be set properly in order to get an accurate count measurement. The setting can be set on the front panel as seen in Figure 4.7. First, the board number must be referenced by looking up the PCI-Quad04 in Measurement Computing's InstaCal software and the setting that value in LabView. Next, the counter number should be set by looking at the C37F-4X9F-1M cable and taking note of the plug number on one of the four ends. Then, the quadrature mode is set using the drop down menu next to "Quadrature" to X1_QUAD.

The quadrature setting is a multiplier that can double (X2_QUAD) or quadruple (X4_QUAD) the number of counts. Next, the CountingMode setting was set to NORMAL_MODE, which means the counter functions as a 24-bit counter that rolls over when the maximum count is reached. Then, the DataEncoding setting is set to BINARY_ENCODING for use with an incremental encoder or BCD for use with absolute encoders. The IndexMode is set to REST_CTR to reset the counter when the Z channel pulse is read every revolution from the encoder. Next, the FlagPins setting is set to CARRY_BORROW. Gating is disabled because index mode is being used.

After the correct settings have been made the LabView code outputs the number of counts produced by the rotation of the 2000 pulse per revolution encoder. Using the count output, data can be manipulated to get degrees of rotation as shown. The math is simply done by dividing by the maximum number of pulses and then multiplying by 360.

Next, an attempt was made to estimate the angular velocity of the DC motor coupled to the rotary encoder. This was attempted by subtracting the current measured degrees from the previous measured value and dividing by the known time interval. The result is a measurement in degrees per second that is then converted into rpm.

Preliminary results indicated that the velocity measurement is not constant and oscillates between two values even at an assumed constant velocity. This is assumed to happen because during one measurement interval half a pulse is measured and during the next the second part of that half is assumed to a whole pulse. Since the computer does not distinguish between whole and half a pulse. The computer counts everything as a whole. The inaccuracy as a result of encoder measurements and speed estimation could be compensated for by averaging multiple measurements.

4.1.1.5 Encoder Signal Testing

A small test apparatus was constructed next, consisting of a DC motor coupled to a rotary encoder. The DC motor was simply a geared dc motor rated at 5 rpm for an input voltage of 4.5 volts. The encoder is a 2000 pulse per revolution optical encoder. Therefore at the maximum operation speed the encoder is expected to have maximum change of frequency of 100 kHz. The encoder's quadrature signal was fed into the PCI-QUAD04. With an input voltage of 3 volts to the motor, LabView only logged 1430 counts within one full rotation out of the maximum of 2000. This speed was noticeable less than the 5 rpm rated speed. This count will become more sporadic with the increase in speed to 3000 rpm. Therefore simply using LabView running under Windows XP will not suffice for the data acquisition needs. Sample of the data collected is presented in the appendix of this report.

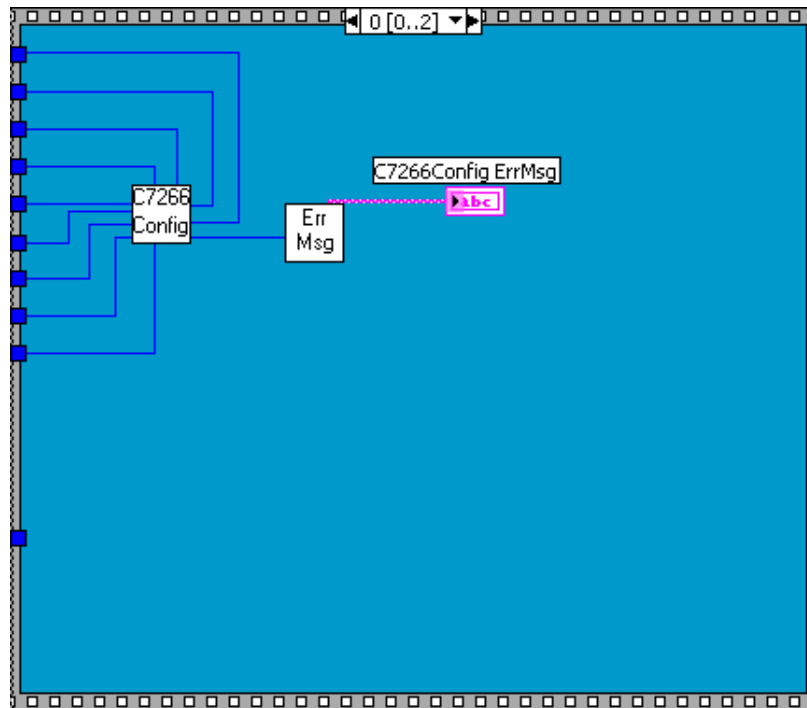

Figure 4.4: Frame 0 LabView Block Diagram Code for Quadrature Encoder

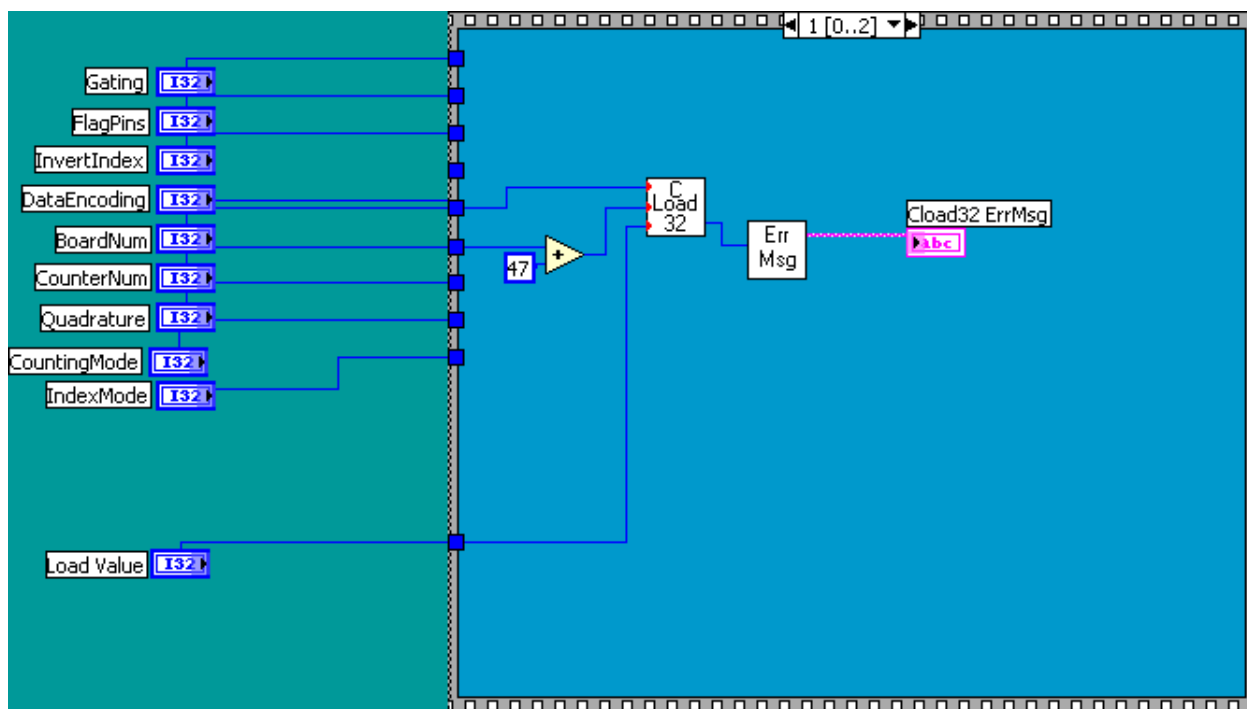

Figure 4.5: Frame 1 LabView Block Diagram Code for Quadrature Encoder

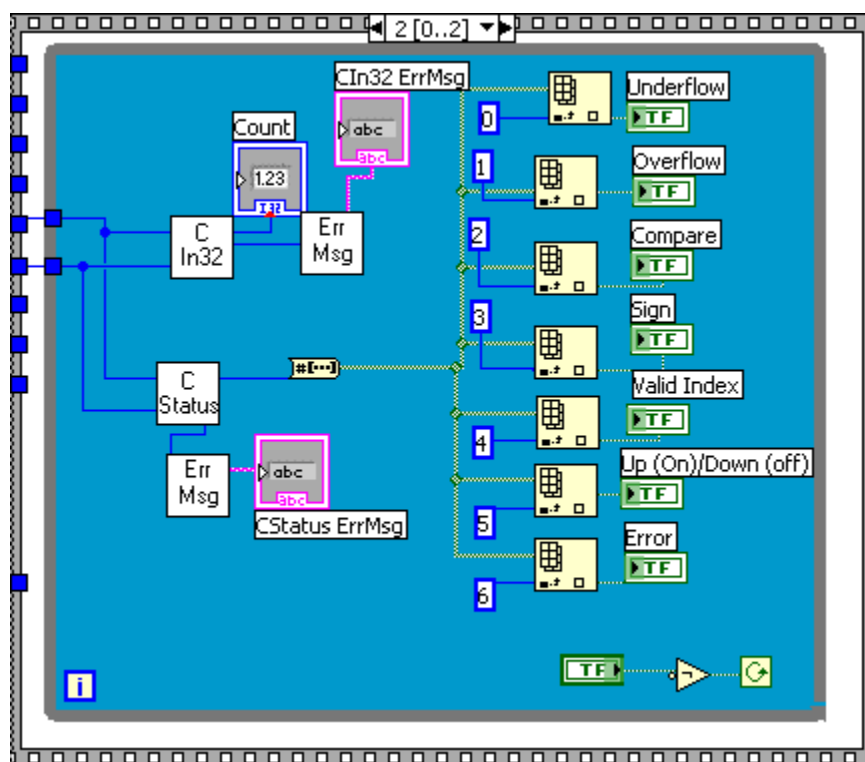

Figure 4.6: Frame 2 LabView Block Diagram Code for Quadrature Encoder

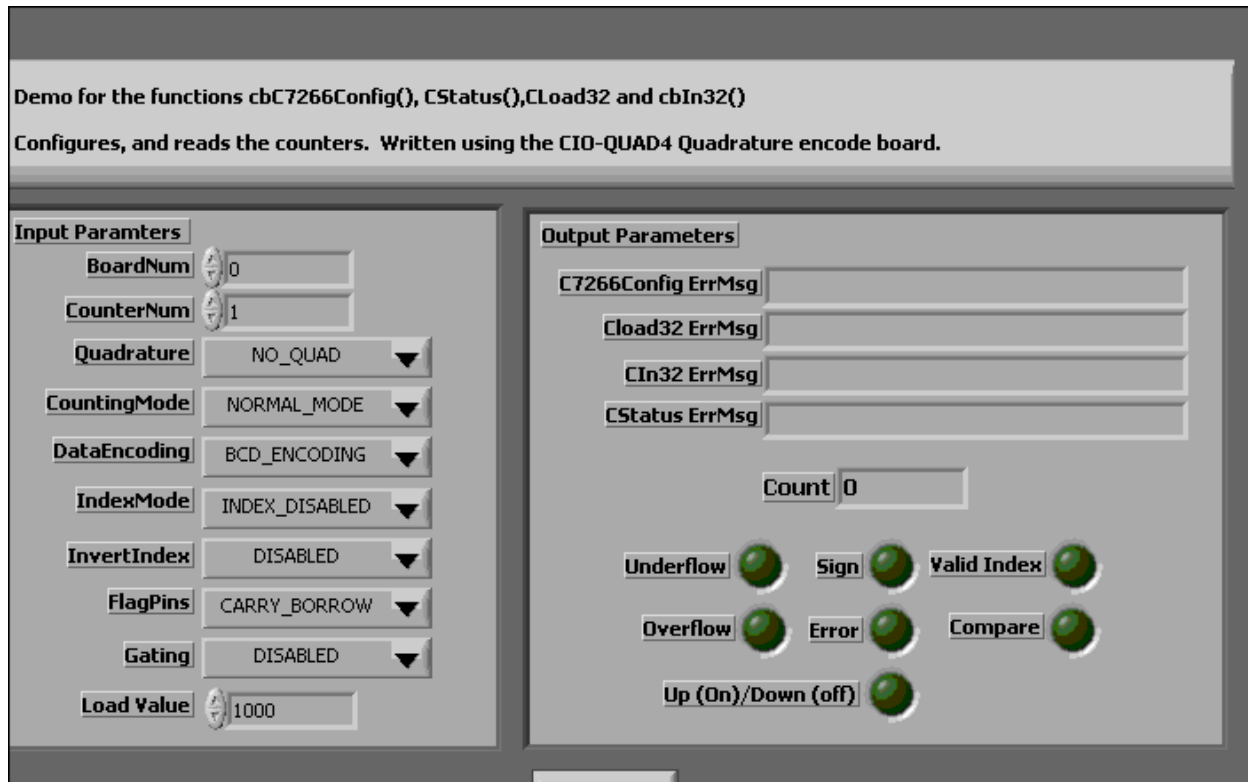

Figure 4.7: LabView Front Panel for Encoder Program

4.2 The Switch to MatLab/Simulink/xPC Target

As stated in the previously section LabView is not adequate for sampling the encoder signal and a new option was researched. The new option came in the form of MatLab with Simulink as the block language for programming. MatLab and Simulink were run under Windows XP for programming the data acquisition experiment. The significant difference was the xPC Target, which runs on a separate “target” computer and has the ability to execute simulations that access the data acquisition boards in real time. The new setup is illustrated in Figure 4.8 below with the main difference being the addition of second desktop computer.

For the desktop computer to process and acquire data in real-time an xPC Target kernel must be implemented. The target computer must be loaded into a different mode. This mode is

induced by what MatLab calls xPC Target kernel. This mode allows the Target computer to execute Simulink models and gather data in real time.

The new data acquisition system is programmed by using the Simulink block programming language. Boards can be found by simply searching by name or going through the block libraries tree. MatLab provides a set of driver blocks sorted by signal type and board manufacturer. For instance the PCI-QUAD04 is used to acquire quadrature encoder signals and therefore is listed in the Simulink library tree under Encoder and then Measurement Computing Inc. because they manufacture the board. The necessary sampling rate is set by double clicking the source block.

The target machine also has a monitor to observe signal operations. Target Scopes are added from the block library to view these signals on the monitor. The Target Scope is one of three xPC Target specific scopes. To send data to the MatLab work space an Out1 block is added. Depending on the automatically assigned Out1 block determines the position of the signal in the acquired data matrix. This system helps keep track of the multiple signals being acquired. The code used to import the data is shown in the Appendix section of this paper. The Out blocks and xPC Target data acquisition blocks can be seen in Figure 4.9.

Using xPC Target system the options when scanning channels differs between analog and digital inputs. For analog inputs the drivers provided by MathWorks only allows one to scan a range of channels and not select individual channels. For instance, one cannot just scan channel five, one must scan channels one through five. Therefore, if only the signal from channel five is needed the connections must be switched or they could affect the overall bandwidth for a test. Digital signals can be picked individually and scanned.

Once data acquisition is completed for one run the data is automatically sent to the host machine. The data is in what is called a target object. This chunk of data is split up by using specific xPC target commands. The first is “tg.timelog” which acquires the target time. Another is “tg.outputlog” which is a matrix of all the output signals. The number of data points remaining in the “tg.outputlog” object is determined by the size of the data buffer. This buffer rolls over after it is filled and starts writing over the first data set. The buffer size is limited by the amount of RAM available on the Target Computer. The buffer size is set under View> Configuration Parameters >Real-Time Workshop>xPC Target options>Data logging options. This value also determines the overall maximum number of data points logged and for each signal this value is divided. The way MatLab calculates this value is by dividing the maximum by the number of signals taken. This calculation can be done in MatLab using the command $\text{floor}(x)$ and the command window, where x is simply replaced by the quotient equation.

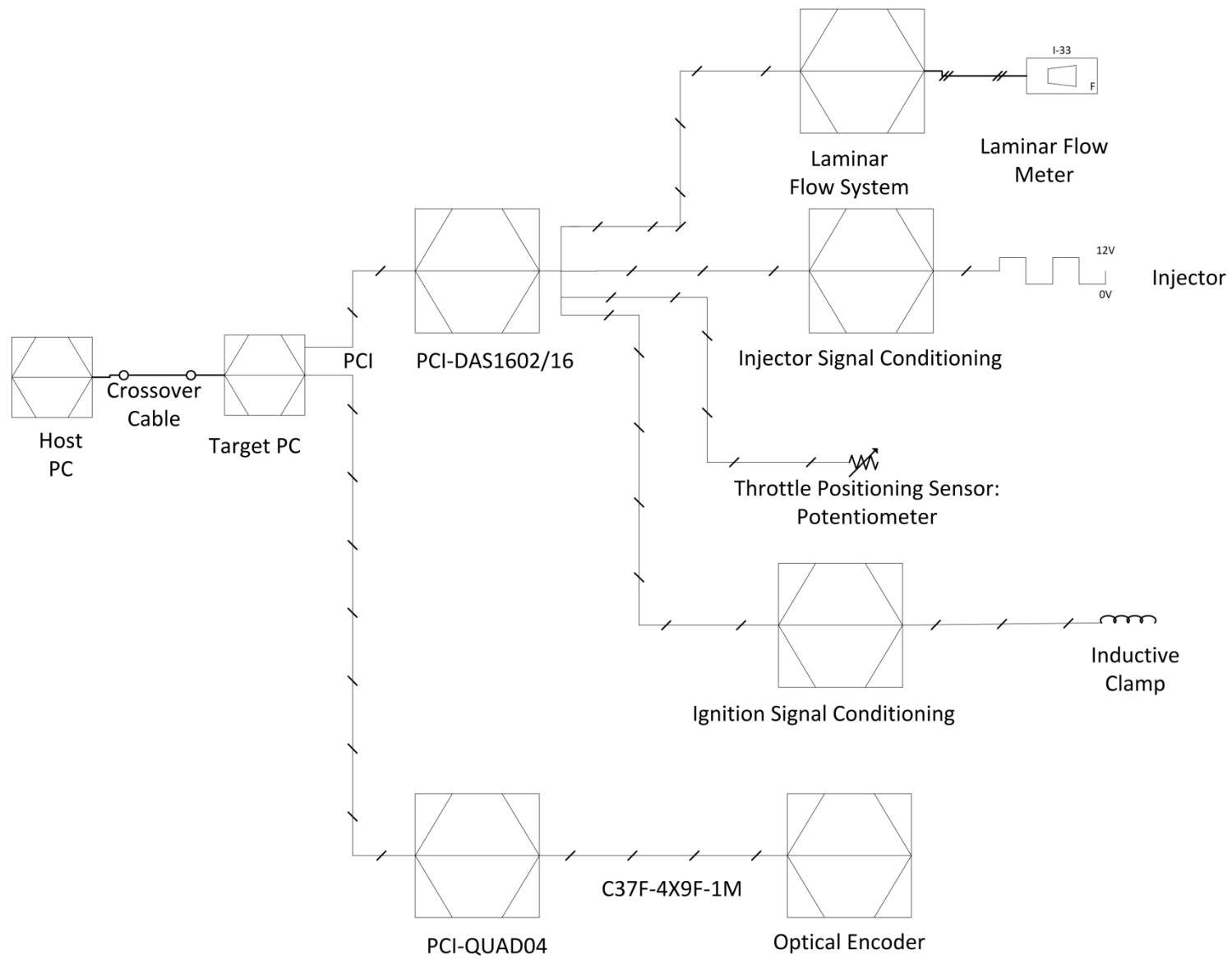

Figure 4.8: Diagram for Hardware Setup with for xPC Target

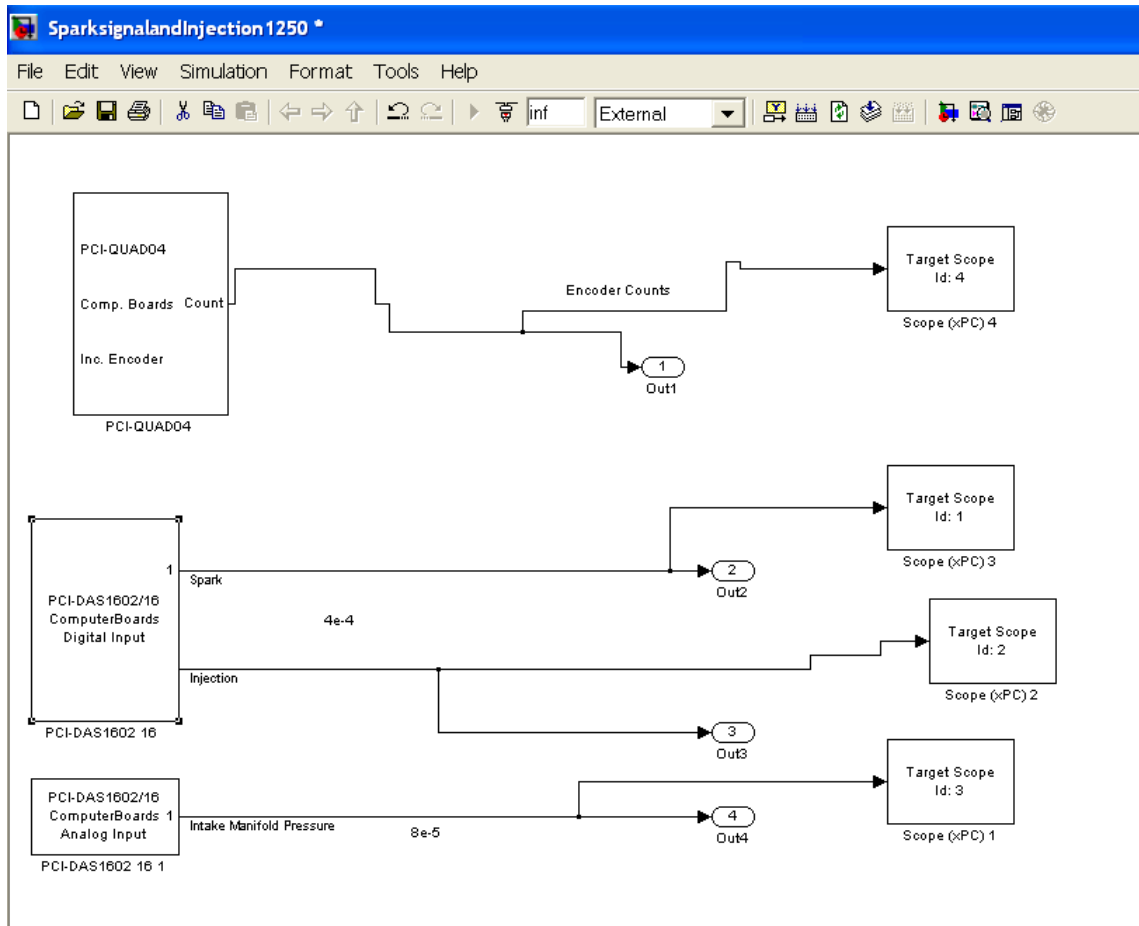

Figure 4.9: SimuLink Screen with xPC Target Blocks

The encoder signal count is reset each time the index is triggered. The index is aligned with top dead center of the engine to give a correlation of how many degrees before or after other signals are triggered such as spark timing and injection timing. Setting for the PCI-QUAD04 can be seen in below. The block programming to capture encoder signals in real time is displayed in Figure 4.9. Where the input block at the far left is the PCI-QUAD04

Parameter	Parameter Value
Channel	1
Index input resets counter	Check Mark
Index Polarity	Negative Index
Counting Mode	Normal
Count Limit or Reset Value	0
Count Range	$-2^{23} \dots +2^{23}-1$
Count Speed	1x
Filter prescale factor	0
Sample Time	0.00004
PCI slot	-1

Table 4.4: PCI-QUAD04 settings in MatLab

The engine sensors will be connected to a computer based data acquisition system. The necessary equipment needed to acquire data from the engine and its various sensors includes a variety of data acquisition boards placed within a personal desktop computer considered the Target PC. The details on the host and target computer used in this study are detailed in Table 4.5 below. A list of these data acquisition boards, the type of signals they can acquire and maximum input frequency can be seen in Table 4.6 below.

Computer	Host Computer	Target Computer
CPU	Pentium 4 3.40 Ghz	Pentium 4
RAM	1 GB	1GB
Operating System	Windows XP	xPC Target real-time kernel
PCI Card Slots		5

Table 4.5: Host and Target Computer System Properties

PCI Cards	Card Description	Maximum Input Frequency (Hz)
PCI-6024E	16Analog-Input Multifunction DAQ	200 kS/s
PCI-DIO48H	Logical-Level Digital I/O Board	
PCI-QUAD04	Encoder Card	1.2 M
PCI-DIO96	96-bit Digital I/O Board	2 M
PCIM-DDA06/16	Analog Output and Digital I/O Board	
PCI-DAS1602/16	Analog and Digital I/O Board	200 k

Table 4.6: Maximum Input Frequency of PCI Data Acquisition Cards

Each PCI card can handle either input or output signals or both. They can accept either digital or analog data as inputs. For the first part of the study of this thesis, data needs to be gathered from different dynamics of the engine. The maximum input frequency of the data acquisition boards and the latency created when using these boards affect the data collection and possible sampling times of each signal.

4.2.1 Analog and Digital Signals

Digital and analog signals are brought into the data acquisition computer using an Analog and Digital input/ output (IO) board (PCI-DAS1602/16). This card is used to sample injector signals, flow meter analog outputs i.e. the intake manifold pressure and intake mass air flow, throttle angle and air/ fuel ratio.

For analog input signals the PCI-DAS1602/16 has software selectable input configuration of 8 differential inputs or 16 single-ended inputs. The PCI-DAS1602/16 has a maximum sampling rate of 200 kHz and a 512 FIFO to help with sampling data and not losing any data. Setting used for analog connections can be seen in Table 4.7 below and digital connection settings in Table 4.8 and Table 4.9. Differences in setting are based on expected input signal and expected maximum frequency of change.

The Figure 4.9 shows the portion of the Simulink code used to program the xPC Target machine for the injector signal. This block code contains a digital input block labeled with the name of the data acquisition card and the type of signal input. An output block is added labeled Out1 to get the gathered data into the MATLAB workspace. Finally a Target Scopes is added to display the data as its being gathered.

Parameter	Parameter Value
Number of channels	4
Range vector	$\pm 5V$
Input coupling	8 channels
Sample time	$5e-5$
PCI slot	-1

Table 4.7: Settings for Analog Input for PCI-1602/16

Parameter	Parameter Value
Channel vector	1
Port	A
Sample time	$5e-5$
PCI slot	-1

Table 4.8: Settings for Digital Input of PCI-1602/16 for Injector Timing

Parameter	Parameter Value
Channel vector	2
Port	A
Sample time	$5e-5$
PCI slot	-1

Table 4.9: Settings for Digital Input of PCI-1602/16 for Spark Timing

4.2.2 Target Machine Benchmark

A benchmark was performed on the target machine to get some idea of the performance capability of the target computer. The performance was done using the internal command “xpcbench”. This command runs the target machine through a battery of tests running increasing more complex models. The does not take into account latency produced by the data acquisition cards currently installed

4.2.3 DC Motor and Offline Testing

Further offline testing was needed to insure that signals could be recorded at the fastest expected change of a signal while doing engine testing. This testing is considered offline because the single cylinder Briggs and Stratton engine is not being used to simply test system limits. The advantage of such testing is the gas is not wasted, the system is simple enough that taking repeated measurements does not take much time and the quickest changing dynamics can be tested i.e. the rotary encoder.

The test setup was comprised of a Normand Electrical Company (NECO) DC shunt motor rated at a velocity of 3000 rpm. Sensors used for testing include a rotary encoder and variable reluctance (VR) sensor. The motor can be seen in to Figure 4.11 below. The figures show a side and top view. The encoder is used to discern crank angle and speed once again, and the VR sensor is used as a second signal to sync with the encoder changes.

4.2.4 Building Stands and Assembly

To get this system put together two stands were made using scrap pieces of aluminum. One stand will be used to hold the rotary encoder in line with the motor shaft and the other holds the VR sensor near the engine shaft.

The encoder was coupled to the DC motor using a Lovejoy coupling. This particular coupling has an inside diameter of 5/8 inches on one end and 1/2 inches on the other for the DC motor shaft and rotary encoder respectively. The Lovejoy coupling is able to withstand speeds of 18,000 rpm as stated in the data sheet. Therefore testing of the xPC Target data acquisition should be able to run up to the 3,000 rpm, which is the rated speed of the motor.

The scraps of aluminum were machined to provide the necessary alignment for the encoder. The center of the shaft was located using a height gage and painting the sheet with blue layout fluid. Using a center punch and the aluminum sheet metal holes were translated from the motor stand to the sheet metal. These holes will be used to mount the aluminum stand to the motor stand. Using bolts that were previously mounted on the motor, the aluminum sheet was attached to the motor. Then, Blue Layout Fluid was applied to the aluminum sheet in the general area where the center of the motor shaft would be. Then, the end of the height gage was placed on top of the rounded portion of the motor shaft. Next, the radius of the shaft (0.25 inches) was subtracted from the value on the height gage. This new height was locked into place and then etched into the Blue Layout Fluid to get a horizontal indicator line. Then the process was repeated for the vertical line with the motor turned on its side. This leaves a center indication where the center of the shaft is located.

With this center point the other three screw holes were located in order to mount the encoder. The other holes were located by first drilling the center hole then using the vertical end mill drilling the hole directly below the center at a distance of 19 mm. The other two holes were located by trigging out the 120 degree rotation from the center to the other two holes on either side of the center hole.

Spacers were added to the sheet metal to finish the stand. These spacers give enough space between the motor shaft and encoder to allow the coupling to connect the two and also provide some rigidity to the structure. The spacers were attached by simply drilling two holes into each spacer and assembling them with screws and locknuts.

Next, the stand that holds the VR sensor was machined using the end mill. The stand is held together with bolts and screws. The base of the stand was counter sunk to allow the stand to sit flat on a surface.

4.2.5 DC Motor Setup Issues

Issues arose when trying to complete this project. Longer bolts were needed to mount the bracket to the motor. First, the original bolts located on the base of the motor were threaded with a usual thread. The screw was threaded with 22 threads per inch with an outside diameter of 5/16 inches. The bolts are believed to have been 5/16 British Standard Fine (BSF) threads. The 5/16 BSF threaded bolt could not be purchased in Statesboro, GA. The solution was to drill out the threads and re-tap the whole with standard thread and bolt size that could be easily purchased.

4.3 Preparation for System Testing

The DC shunt motor was operated to get a correlation between motor speed and tachometer output voltage. The motor speed was measured using a photo tachometer pointed at a piece of reflective tape on the black encoder wheel that was attached to the motor shaft. The voltage versus speed correlation will be used for the control of the dc motor. The expected voltage output is 2 volts per 1000 rpm. As seen in Figure 4.13 below when plotting the tachometer voltage output versus speed the slope of the line is 0.0026 which means about 2.6 volts per 1000 rpm.

The VR sensor and two metal nuts and screws are used to generate a signal every time one of the screws passes the sensor. The VR sensor with stand can be seen in Figure 4.12. The VR signal will then be logged with the crank angle using xPC Target.

4.3.1 Control of DC Motor

In the attempt to control the DC motor to aid in the testing process digital control strategy was attempted. The strategy included the use of a Basic Stamp 2 microcontroller, H-Bridge, and Schottky Diodes. The assumption was that using the above components and pulse width modulation to either the shunt or armature of the dc motor the motor could be controlled. The DC motor already had a tachometer on the back of the motor that could be used as a feedback signal. The output of the voltage of the tachometer was to be divided to protect the microcontroller.

Reasons for the inability to drive the motor could come from lack of knowledge in how shunt motor control works or the microcontroller being unable to produce enough pulses to ultimately drive the test system.

The microcontroller setup was abandoned and switched to using the DC power supply. Using the power supply the armature and shunt of the motor were powered separately. Using this simple configuration and an oscilloscope to monitor the tachometer voltage for speed confirmation the test set-up became very useful. The test setup still required a little tuning to make the speed stable.

The test set could be used to generate data at up to 3000 rpms that then can be taken into Matlab for further manipulation such as sending the data to Excel.

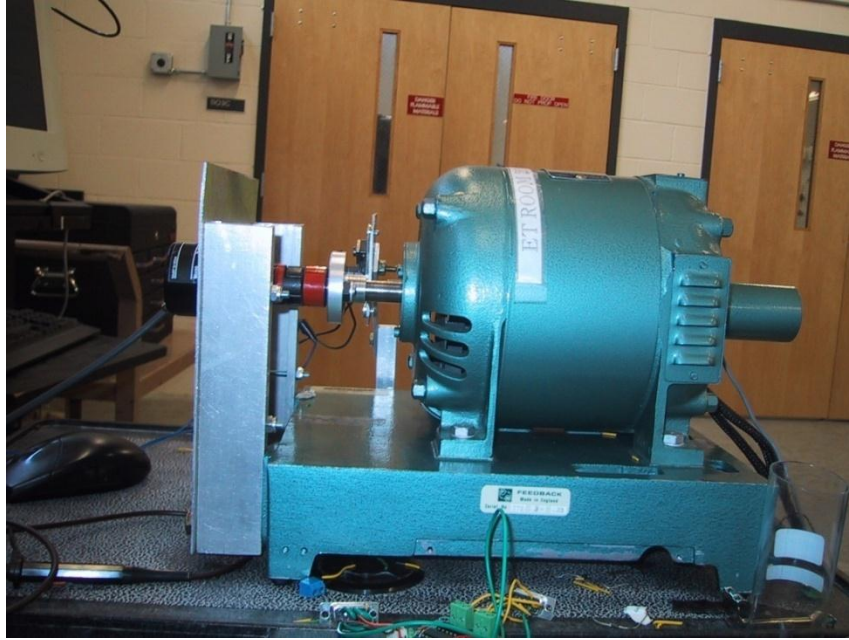

Figure 4.10: Stand for Mounting Rotary Encoder to DC Motor Shaft

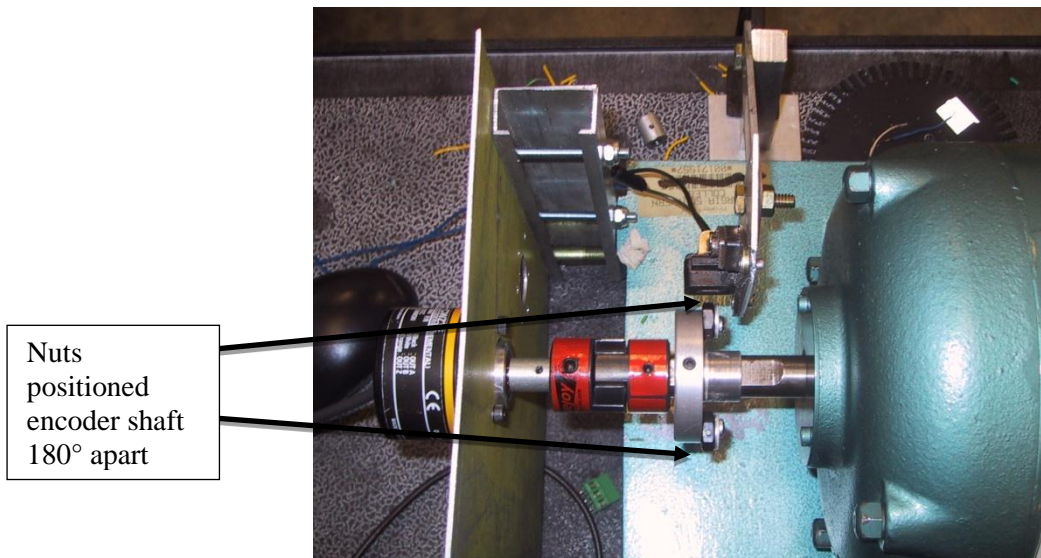

Figure 4.11: Top View of DC Motor with VR Sensor

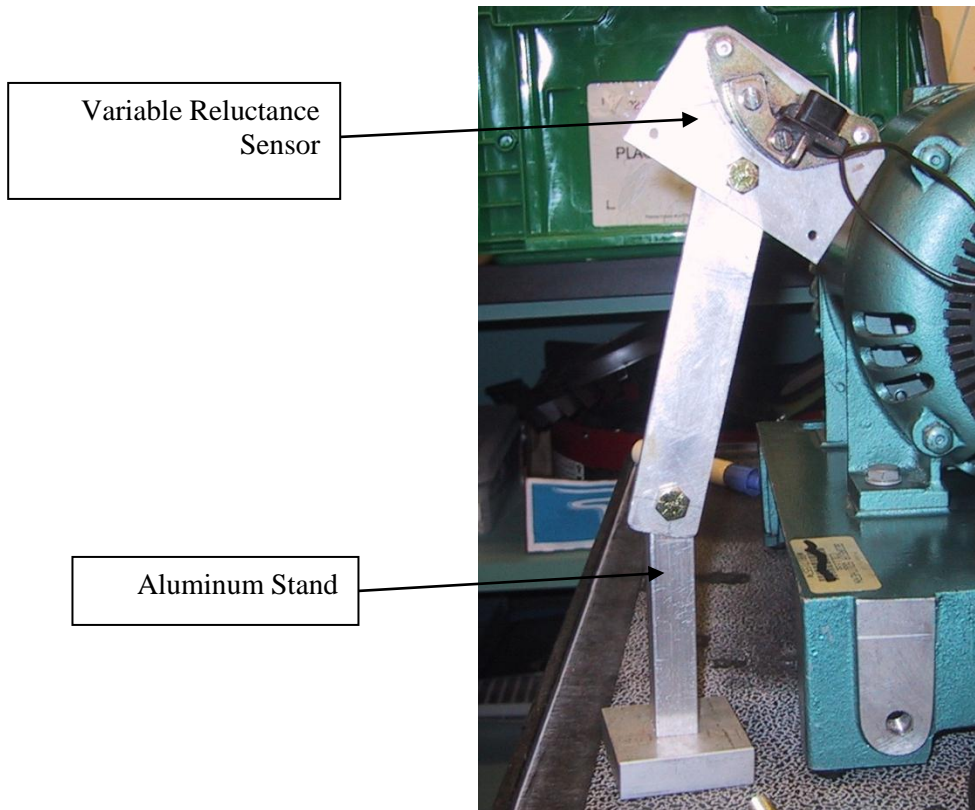

Figure 4.12: Stand for VR Sensor

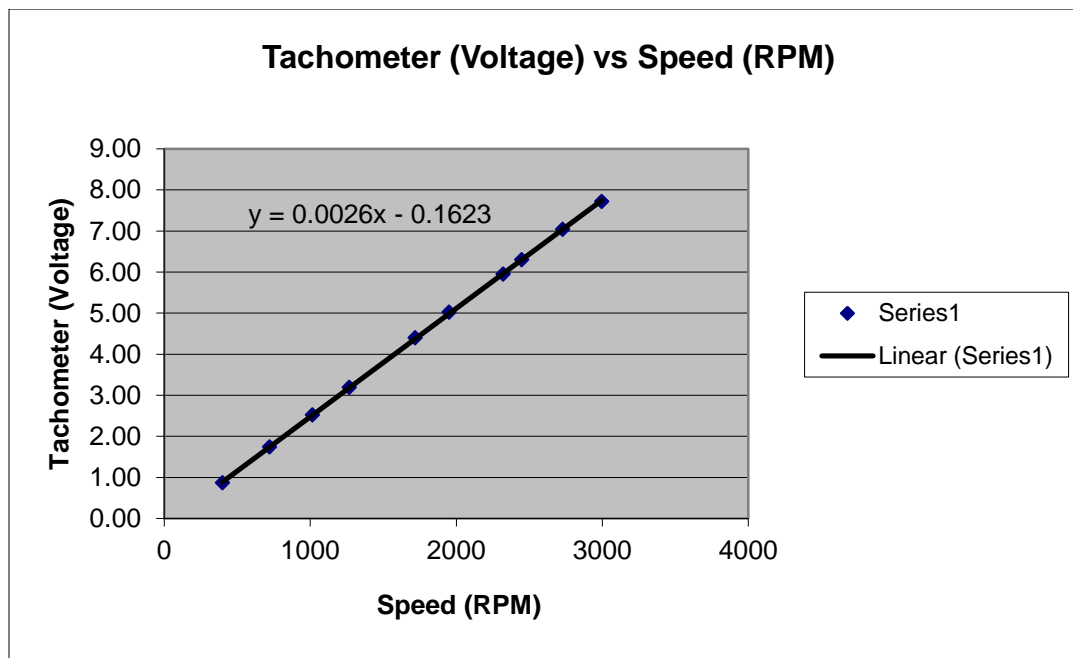

Figure 4.13: Output Tachometer Voltage versus NECO DC Motor Speed

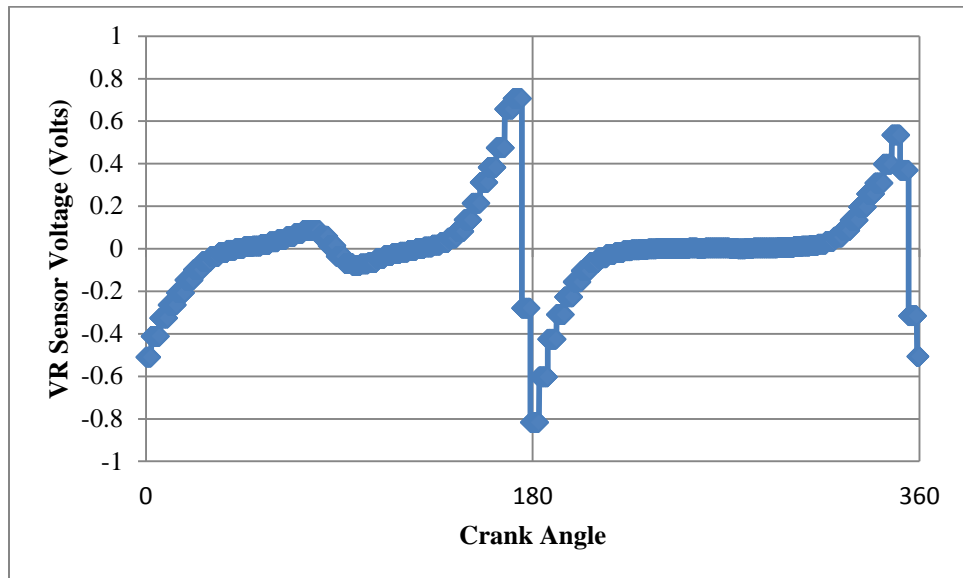

Figure 4.14: Plotted data of encoder position versus VR sensor

Through plotting of this data as seen in Figure 4.14 the data shows that the VR sensor can be captured and plotted using the xPC based data acquisition system. The transition from positive to negative voltage represents the position of the two nuts placed 180 degrees apart on the electric motor shaft as seen in Figure 4.11.

The xPC Target computer does not have enough bandwidth to capture all the pulses of the rotary encoder and include other signals. Therefore the encoder signal needs to be divided. In order to divide the signal a circuit is needed to divide and reduce the maximum amount of pulse between each Index passing. This reduced the resolution of absolute angular measurement, but this can be alleviated by averaging over many counts.

4.4 Sensors

Other devices used for gathering the engine dynamics include a rotary encoder, type K thermocouples and mass air flow measurement system. The rotary encoder is used to measure engine speed and crank angle. There are two thermocouples used to measure intake and exhaust manifold temperatures. Final, the mass air flow measurement system comprised of a differential pressure laminar flow element (LFE) and laminar flow system (LFS). The frequencies of change of these devices are listed in Table 4.10.

Sensor Number	Sensor	Measurement	Frequency of Measurement (Hz)
1	Rotary Encoder	Engine Crank Angle and Engine Speed	100K electrical
2	Potentiometer	Throttle Angle	100
3	Thermal Couple Type: K Tolerance Class 1	Intake Air Temperature	0.25
4	Thermal Couple Type: K	Exhaust Air Temperature	Not Available at the Moment
5	Injector	Injector Timing	200K
6	Horiba	Emissions Gas Analysis	CO, HC, CO ₂ 15 s (0.067 Hz) O ₂ 15s (0.067 Hz) NO 40s (0.025 Hz)
7	Oxygen Sensor	Air/Fuel Ratio	Not Available at the Moment
8	Inductive	Spark Plug	200K
9	Laminar Flow System	Intake Mass Air Flow	30 values per second (30 Hz)

Table 4.10: Sensors and Maximum Frequency of Measure

4.4.1 Crankshaft Rotary Encoder

The crankshaft is a key measurement point. The cranks shaft with the connecting rod translates the reciprocating motion of the engine into rotations. This connecting point provides a point to measure engine speed and crank angle.

To measure the engines speed and crank angle an Omron incremental rotary encoder is used. The encoder works by having a disc inside with multiple equally spaced slits cut out. These slits allow light emitted from a LED internal to the encoder to hit a sensor inside the encoder. Therefore, as the encoder spins pulses are generated when the sensor picks up the LED light. There are three tracks of these slots called channels. The first two channels are usually called channel A and B. Channel A and B generate a signal when the encoder is spun that is 90 degrees out of phase with each other. This difference in phase allows the direction the encoder is spinning to be identified. The third channel usually designated the index or channel Z, generates only one pulse per revolution. The Z channel is used to reset the encoder counts in data acquisition and to sync the encoder with top dead center (TDC) of the engine.

The encoder is coupled to the engine crank shaft parallel with the engine spinning axis. The rotary encoder has a resolution of 2,000 pulses per revolution. This resolution provides an accuracy of 0.18 degrees per pulse. Therefore there are 4,000 pulses or counts within one four stroke process. These 2,000 pulses per revolution can generate a change on frequency at 3,000 rpm engine speed of 100 kHz. At 100 kHz the bandwidth of the data acquisition computer will be almost total used up on the one signal alone. Therefore the signal needs to be divided in order to ensure the encoder signal is not sporadic. To divide the encoder signal a commercially available encoder divider from BaneBots was selected. The encoder divider enables divisions of 4, 8 or 16. The results of this division and the effects on resolution and the bandwidth usage can be seen in the table below.

4.4.2 Flow System Measurements

The Laminar Flow System requires a plug to connect to the two analog outputs. A Neutrik NC5MX five pin plug is used to provide an external connection. Pins 1 and 2 are the positive

and negative outputs respectively of the first analog output while pins 3 and 4 are the positive and negative outputs of the second analog output as seen in the Figure 4.15. Pin 5 is connected to ground on the target computer and the LFS. The first analog output is for the mass air flow and absolute air pressure for the first and second analog output respectively. A diagram of the connection can be seen in Figure 4.15.

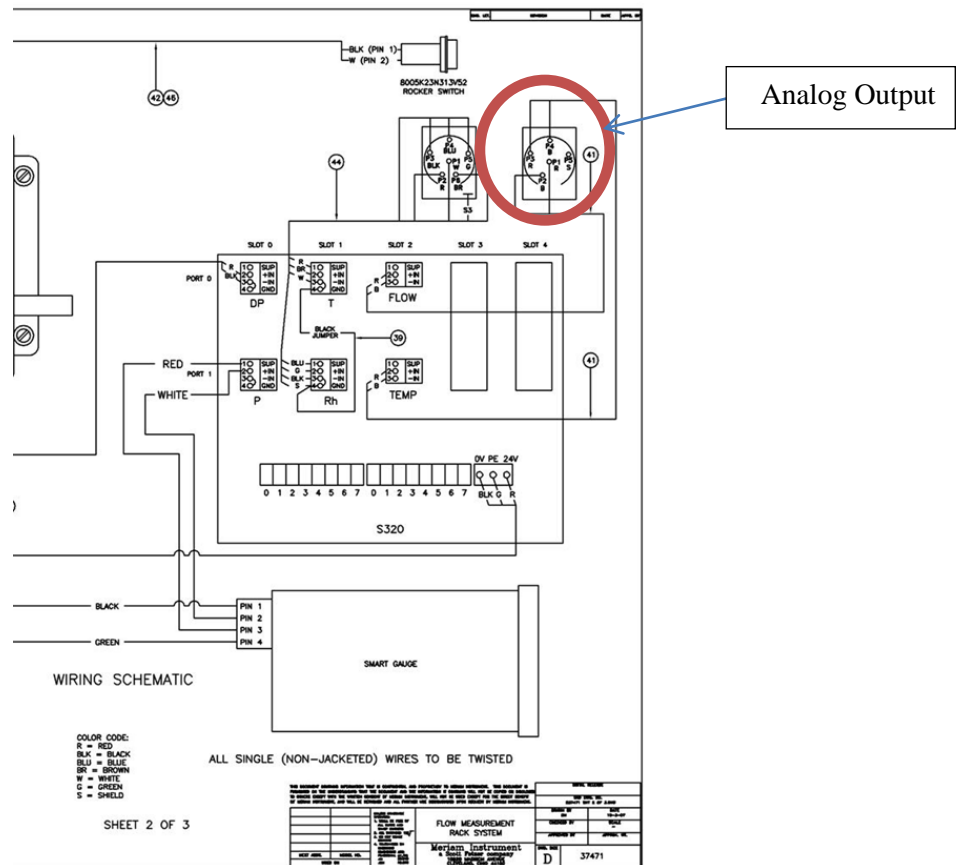

Figure 4.15: Laminar Flowmeter Analog Output (Meriam,2010)

The LFS-1 Analog output can be changed by the serial port or manually using the front panel of the S320. The parameters that need to be changed are in section Px900 of the parameter blocks.

4.4.3 Mass Air Flow

The mass air flow and absolute manifold pressure meter is measured using the Meriam pressure measurement system. The Meriam system includes two devices, the Laminar Flow Element (LFE) and Laminar Flow System (LFS), seen in Figure 4.16 and

Figure 4.17 respectively. The LFS measures the pressure drop across the LFE using a pressure transducer within the LFS. Then, using a probe to measure humidity and the surrounding air temperature upstream of the LFE, the LFS does flow calculations and corrections. These two measurements, the mass air flow entering the manifold and the pressure reading inside the manifold are very important. The mass air flow is calculated using the pressure difference across the LFE and the pressure is taken from the high flow entrance of the LFE. The analog output from the LFS is a linear output of 0-10V for representing the mass airflow and pressure read by the data acquisition PC.



Figure 4.16: Meriam Laminar Flow System (LFS) (Meriam, 2010)



Figure 4.17: Meriam Laminar Flow Element (LFE) Z50MC2-2 (Meriam, 2010)

4.4.4 Throttle Position Sensor (TPS)

The TPS is the main input signal for engine control. To identify the angle the throttle is open a potentiometer is positioned on the underside of the intake manifold directly under the throttle plate. The potentiometer outputs a signal from 0.901 to 4.44 volts from closed to wide open throttle. For engine testing the throttle will be set to a constant angle. The image of the TPS can be seen in Figure 4.18.

A correlation between the throttle angle and voltage output is simply made using an oscilloscope and the percentage of open throttle using the Engine Management Systems' electronic control unit (ECU) display. As seen in Figure 4.19.



Figure 4.18: Engine Throttle Positioning Sensor

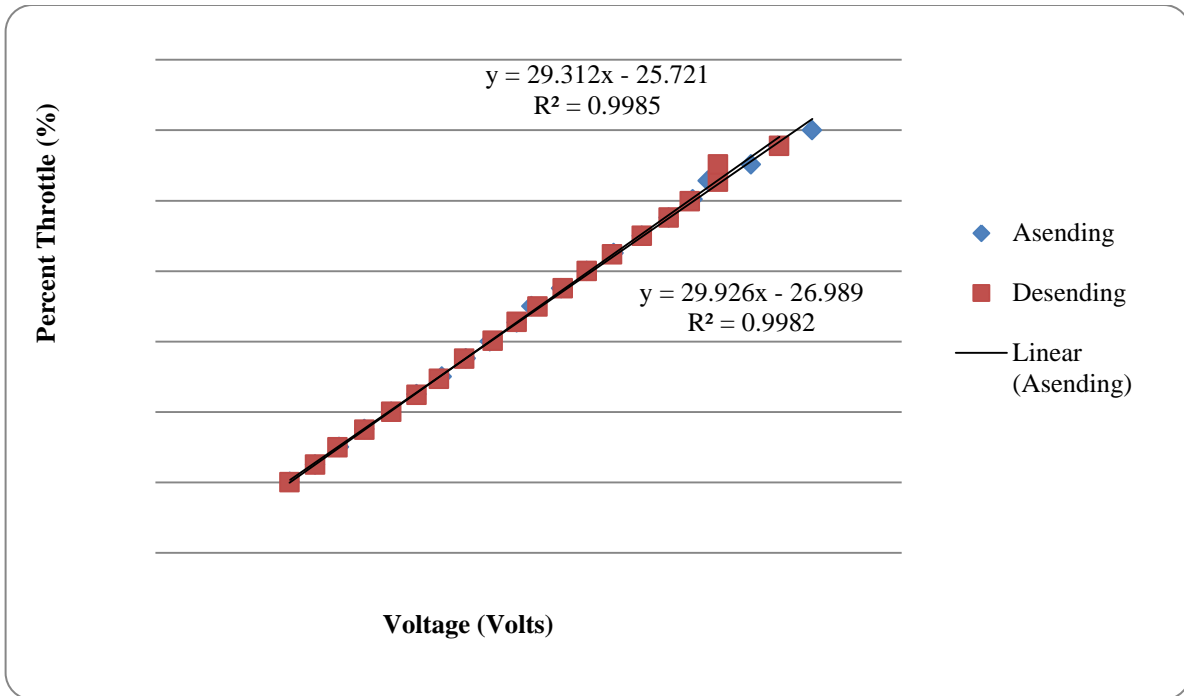

Figure 4.19: Voltage versus Throttle Angle for TPS

4.4.5 Injection Sampling Circuit

Reading when the injector fires and the duration of the firing signal is essential for generating any model needing injection timing. The injection timing needs to be sampled without affecting the operation of the injector. Therefore a direct connection between the data acquisition hardware and the ECU to injector signal is not ideal as any voltage above 15 volts could damage the data acquisition card.

The ECU signal going to the injector needs to be read while taking care not to reduce power going to the injector or damage the computer, data acquisition equipment, or people taking data. This will be accomplished by using a MOSFET based circuit. As seen in the Figure 4.20. The MOSFET used is an IRF630 which is an N-channel enhanced mode MOSFET.

The MOSFET is will be setup with the 12 volt injector signal being applied to the gate. The drain will have a constant 5 voltage signal coming from the PCI-DAS1602/16 digital and analog card. A 1 kilo ohm resistor is placed in series with the source output. The voltage across the 1 kilo ohm resistor will then be read by the PCI-DAS1602 as a digital signal.

With the MOSFET setup for the injector signal when the injector fires a channel is created within the MOSFET that allows the 5 volts from the PC to be sensed at the source. By only reading the 5 volts that passes through the MOSFET and not the 12 volts directly from the ECU, the data acquisition system will be safe. The circuit design can be seen in Figure 4.20.

A diode was added to the gate of the MOSFET as seen in the Figure 4.20. The diode was added to fix a grounding issue. That was caused when the engines ECU tried to find a grounding point on the data acquisition computer. The injector was a Bosch Suzuki injector with model number 2500431 with impedance of 20 ohms. A diagram of the circuit can be seen in Figure 4.20.

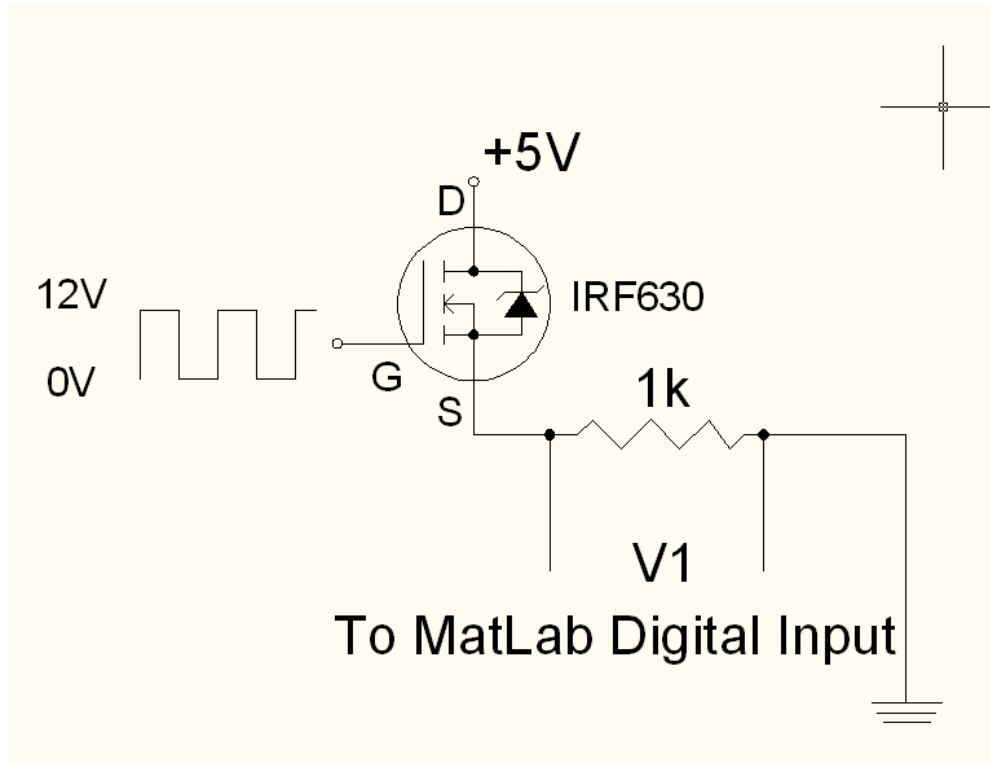

Figure 4.20: MOSFET Injector Sampling Circuit

4.4.6 Second Injector Sampling Circuit

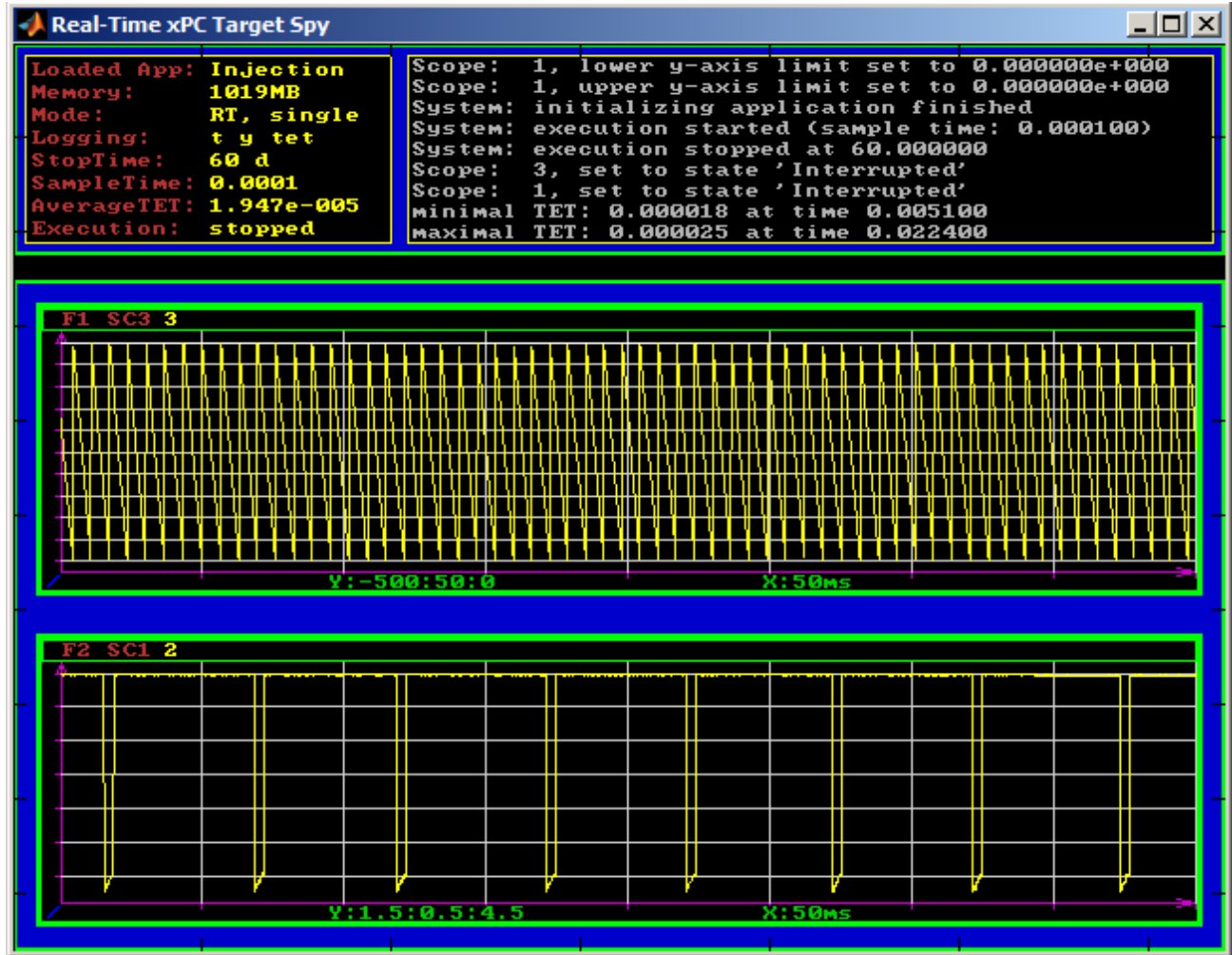

Figure 4.21: The Encoder Signal and Injector using First Injector Circuit

The injector signal would not register as a digital signal. The signal registers as remaining high because as seen in the figure the signal is not pulled all the way down to zero. The signal only as low as 1.5 V, but the digital input on the PCI-DAS1602/16 needs the signal to go as low as 0.8 V. To solve this issue the suggestion is to invert the incoming signal using two MOSFETs. The researched configuration requires the use of two MOSFETs one P type and the other N type. The first test using the engine resulted in the FETs getting hot to the touch, therefore testing stopped. The circuit will be retried using a signal generator and oscilloscope.

The circuit was redone and tested using a function generator and oscilloscope. The actual injector signal was compared to the output of the inverting MOSFET. The results were as expected with the output of the circuit was the inverse of the injector signal.

The results of the retest sampling the actual injector proved reliable and enabled further engine testing to resume. The final inverting can be seen in Figure 4.22.

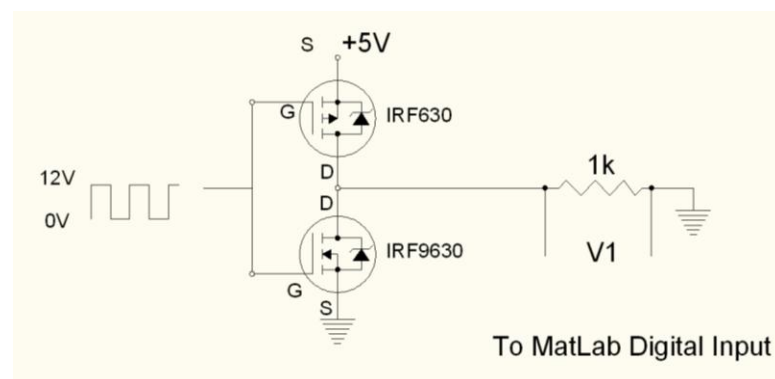

Figure 4.22: Circuit for inverting injector signal

4.4.7 Thermocouple

Thermocouples are used to measure the temperature of the air at the intake and the exhaust gas as it exits the engine. Type K thermocouples are used for both measurement points. A type K thermocouple works by having two dissimilar metals welded together at the tip of the thermocouple probe. When the two dissimilar metals come into contact a thermoelectric junction is formed. The standard type K thermocouple is comprised of Nickel Chromium alloy and a Nickel Aluminum alloy leads. Type K thermocouples have a temperature range of -270 to 1372 °C. The diameter and type of thermocouple determines the frequency of change in temperature can be noticed. (Alciatore & Histan, 2005) (National Institute of Standards and Technology, 1995)

4.4.8 Thermocouple Data Acquisition

The sensors for the current study will be attached as follows. The PCI-6024E is connected to a SCC-2345 signal conditioning board. The SCC-2345 contains two SCC-TC01 thermocouple input modules. The SCC-TC01 takes in the thermocouple voltage and does cold-junction compensation using a thermistor to measure the reference temperature. Then, the thermocouple voltage and cold-junction compensation voltage are used to calculate the thermocouple temperature. The temperature is correlated to the temperature voltage read by the target machine.

To acquire temperature measurements from thermocouples a conversion is needed between the thermocouple voltage and temperature. To get this correlation a known temperature is compared to the voltage. The known temperature measurement was provided by an Extech 470 which can read between -20 to 750 Celsius with a resolution of 1 degree Celsius. The Extech provides an accuracy of 3.0% for the reading for the measurement circuit and 3 digits for the analog to digital converter. The correlation was attempted by using boiling water in beaker and measuring the temperature with the Extech 470 and computer based data acquisition. Then the voltage and temperature were recorded. With this method a temperature of only 94 degrees Celsius can be reached because the water starts boil.

Since the above testing limits the range of possible temperatures to only 94 degrees Celsius another method will be attempted. Using an E5CS Omron Temperature Controller to read the exhaust temperature and comparing that to the actively recorded voltage of the data acquisition system to get a new correlation at those extreme temperatures.

The second and final solution is to use the later purchased temperature controllers. The controller is an Omega temperature controller with a linear output of 4 – 20 ma. A 250 ohm

resistor will be connected to give a maximum of 5 Volts as the output. The resulting voltage will be fed to the data acquisition analog connection.

4.4.9 Wideband O₂ Sensor

The wideband oxygen sensor allows the air to fuel ratio of the engine to be recorded. This sensor can also be used in data acquisition and closed loop control of the engines emissions. The lambda sensor is a Bosch Lambda Sensor LSU 4.2. The lambda sensor has an accuracy at lambda values of 1, 0.8 and 1.70 of 1.016 ± 0.007 , 0.80 ± 0.01 1.70 ± 0.05 respectively. (“LSU42.pdf,” n.d.)

The Bosch sensor is then interpreted by Zeitronix Zt-3 Wideband Air/ Fuel Ratio Meter. The Zt-3 is capable of reading lambda values between 1.43 to 0.64 and air to fuel ratios from 21.0 to 9.0. For data acquisition the Zt-3 outputs an analog signal representing the air to fuel ratio value. An example of the sensor used can be seen in Figure 4.23. (Zeitronix, 2011)



Figure 4.23: Wideband Air to Fuel Ratio Sensor (Bosch, n.d.)

4.5 Signal Conditioning and Sensors

4.5.1 First Attempt Encoder Dividers

The rotary encoder has a resolution of 2,000 pulses per revolution. This resolution provides an accuracy of 0.18 degrees per pulse. Therefore there are 4,000 pulses or counts within one four stroke process. These 2,000 pulses per revolution can generate a change on frequency at 3,000 rpm engine speed of 100 kHz. At 100 kHz the bandwidth of the data acquisition computer will be almost completely used up on the one signal alone. Therefore the signal needs to be divided in order to ensure the encoder signal is not sporadic. To divide the encoder signal a commercially available encoder divider from BaneBots was selected. The encoder divider enables divisions of 4, 8 or 16. The results of this division and the effects on resolution and the bandwidth usage can be seen in the table below.

The data acquisition setup and encoder dividers were tested to ensure the set-up would work. Two BaneBots encoder dividers are used for channels A and B. Each channel is fed into both encoders, but the primary signal is switched to divide each channel. A diagram of the connections can be seen in the Figure 4.24.

The “division amount” affects the frequency of the input signal into the quadrature encoder card PCI-QUAD04. In Table 4.11 the division amount can be seen.

Encoder Divide Amount	Maximum Encoder Counts After Division	Resolution (Degrees per Pulse)	Frequency of change at 3000 rpm
4	500	0.72	25000
8	250	1.44	12500
16	125	2.88	6250

Table 4.11: Results of Dividing Encoder Counts on Resolution and Frequency

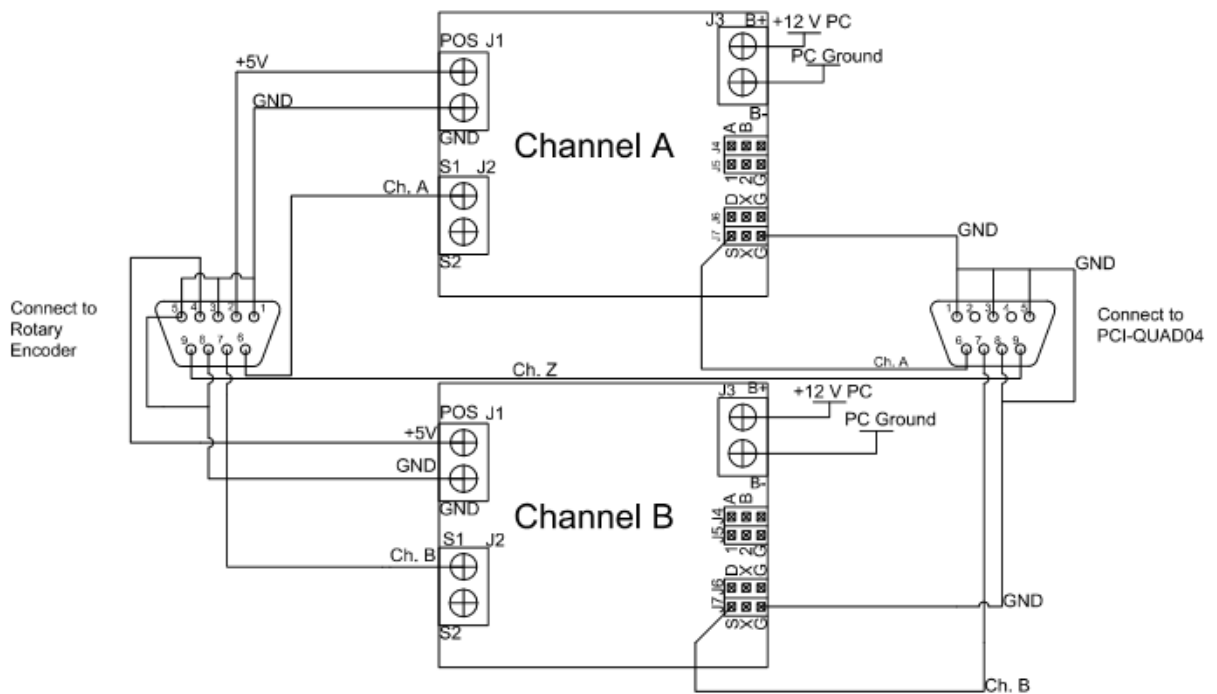

Figure 4.24: Banebots Encoder Dividers to PCI-QUAD04

4.5.2 Encoder Signal Issues

The process to diagnose the encoder issue will be presented in the section below.

Originally the encoder signal became unpredictable while running the engine and using the simulation with the dc motor. The encoder signal would either become jagged with respect to time or decrement when expected to increment upwards. From observing output of the encoder dividers the signal became unpredictable.

In the attempt to sample data from the rotary encoder, injection signal, inductive clamp and manifold pressure from the laminar flow meter simultaneously, the encoder failed to produce a signal. In an attempt to solve the issue, the encoder was checked alone without encoder divider to see if a signal could be produced and recorded by the data acquisition xPC Target machine and host. This attempt was successful. The assumption was to then check the encoder divider box.

The encoder divider box was checked to see if it would produce a signal. At first the signal was not as expected. The encoder divider for dividing the B channel was not dividing the channel as expected. Then a continuity check was done on the encoder divider to check particularly the grounded points using the BaneBots Encoder Divider Card Manual and schematic as a guide. It was found that the ground at block J4 was not soldered correctly. The points were re-soldered and the encoder was checked again using the DC motor and Oscilloscope. The connections appeared to be as expected with channel A and B having the ideal 90 degrees phase shift and same amount of divisions. Last, a test was done again with DAQ system and Briggs engine. No signal was seen on the target machine.

The next attempt used LabView to test the connection. With the encoder divider plugged in between the encoder and the input to the encoder card a signal was recorded. The issue occurs inconsistently.

The 90 degrees shift in phase usually need to discern the direction of rotation of the encoder was not of the normal state, instead channel B seemed to be leading channel A versus the norm of the reversal. Oddly the DAQ computer still read the signal proceeding in a clock wise direction with the count value increasing from 0 to 500 and resetting back to zero. A solution for this could be an opto-isolator or a D-Type Flip Flop to extend the signal. The encoder issue was solved by not splitting each channel as they entered the signal conditioning box. According to the encoder manual specification only one signal needs to be divided, while the other is used for direction. Only the input into S1 is needed to divide the encoder signal. The splitting of each of the encoder signal channels is believed to have caused fan-out and therefore unpredictable results. Therefore channel A goes to S1 of one encoder

divider and channel B goes to S1 of the second encoder. The encoder dividers problems reoccurred later in testing where in channels A and B did not have the 90 degrees phase shift.

If the encoder divider problem persists a D-type flip flop may be implemented. From researching the recurring issue a potential solution of increasing the distance between the phase of channel A and B could give the target machine more time to discern the direction the encoder is spinning. This will ideally cause less problematic behavior in the generated signal.

4.5.3 Second Encoder Divider

Considering the issues generated from the previous Banebot encoder divider setup another encoder divider was purchased from US Digital. This encoder divider has an input frequency of 1.0 MHz

4.5.4 Wiring of Signals

In an effort to decrease noise within the signal all analog input connections were switched from single-end input to differential connections. These connections included analog output from mass air flow sensor, air to fuel ratio from Zeitronix wide air band sensor and throttle positioning sensor (TPS). The switch seemed to improve the signal, but not totally clean up the signal. Further conditioning will be attempted following the guide given by Measurement Computing. ("Guide to Signal Connections," 2006)

4.5.5 Inductive Sensor

The spark signal was coupled to the crank angle to get the firing angle relative to top dead center. To record the point when the spark plug fires relative to crank angle an inductive sensor was used. A clamp containing the sensor is placed around the spark plug wire. The inductive pick-up is an off the shelf clamp that conveniently has an audio jack connection. The

inductive signal is fed into a circuit that eliminates the noise and produces a square wave with an up time of about 2.0 milliseconds. The circuit consists of three 1N4148 diodes, a BT149 SCR, one 10nF, one 100nF, one 47nF, one 1K ohm, one 3K3 ohm, one 10K ohm and 18K ohm resistor and a NE555 555 Timer. The 555 Timer produces the square wave signal with the 100 nF capacitor and 18K ohm resistor which determines the duration of time the signal is at the high state. This duration can be determined by the equation below.

$$\Delta T = 1.1 * R * C \quad (4.2)$$

where R is the value of the resistor and C is the value of the capacitor.

Substituting the values of the 18k ohm resistor and 100 nF capacitor into Equation (4.2) the results are seen in Equation (4.3).

$$\Delta T = 1.1 * 18K * 100 \text{ nF} \quad (4.3)$$

$$\Delta T = 0.00198 \text{ seconds}$$

Therefore with the 555 Timer the signal output to the DAQ computer will stay high for about 2 ms. Through inspection of a set of data the pulse high was 1.8 ms. The spark duty cycle can be seen in Figure 4.27. The spark timing relative to crank angle is presented in Figure 4.28.

The shows the inductive clamp circuit and the purchased inductive clamp. The clamp has a 3.5 mm jack that can be easily integrated with the circuit to gather the low inductive voltage.

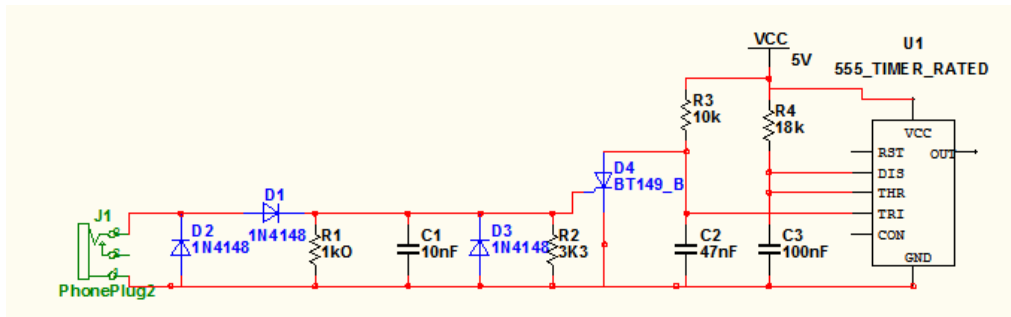

Figure 4.25: Inductive Clamp Signal Conditioning Circuit

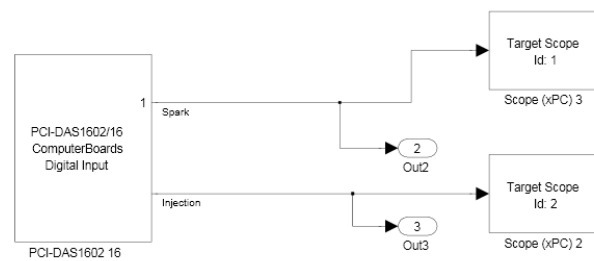

Figure 4.26: Simulink Block for Injector Signal

Figure 4.26 illustrates the injector signal Simulink programming blocks. The injector signal is sampled as a digital signal using the block on the left. The next two blocks enables the signal display on the target machine and the output block to the MatLab workspace for further processing.

4.5.6 Preliminary Data from Inductive Clamp

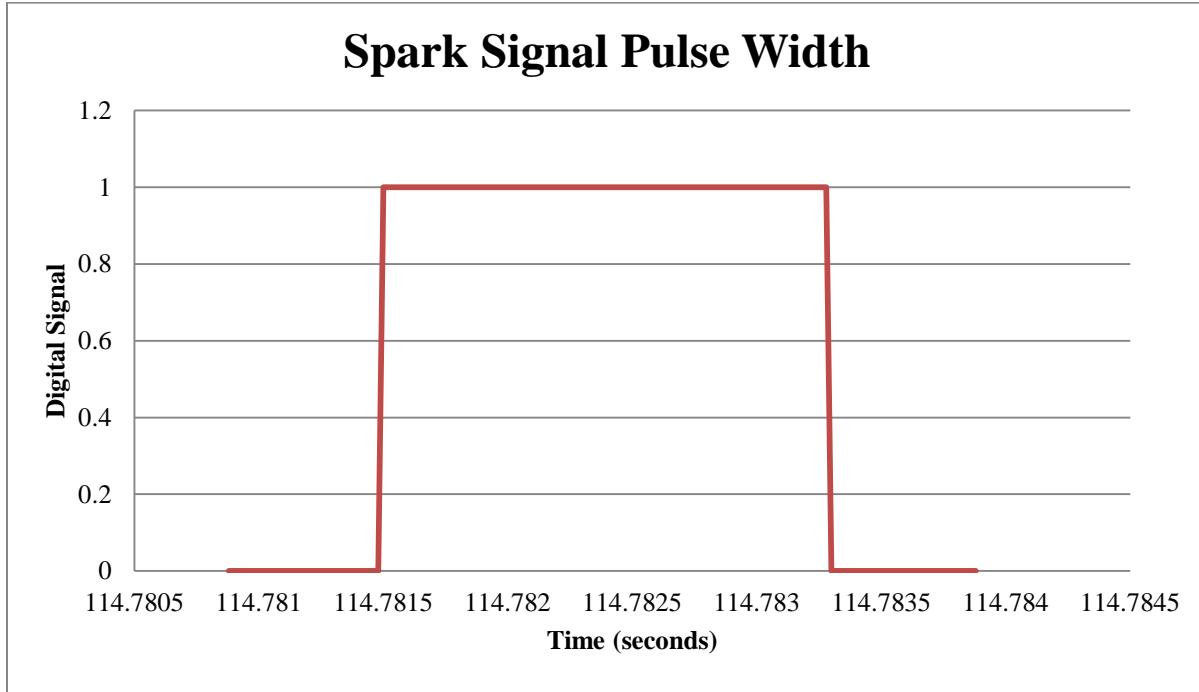

Figure 4.27: Inductive Clamp Signal versus Time

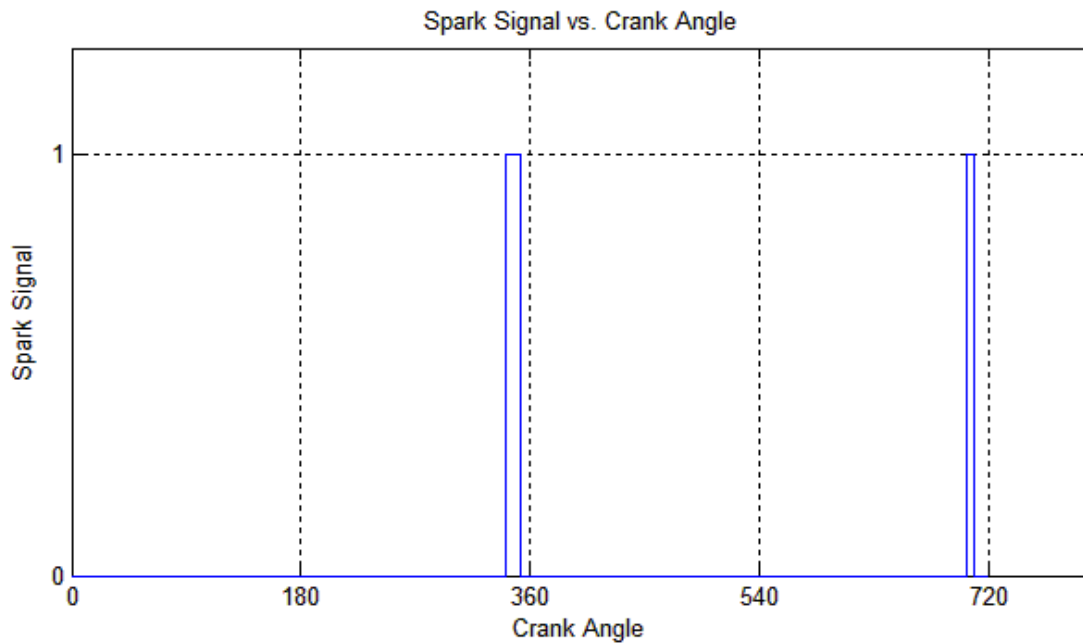

Figure 4.28: Spark Signal versus Crank Angle

4.5.7 Single Cable Connection

To aid in the frequent movement of the data acquisition system a serial connection was implanted. This male to female serial connection combines all of the wires going from the engine sensors to the data acquisition system. These wires were placed in a DB-9 connector. The five connections are shown in Table 4.12 below. The signals come from the injector, throttle position, and the analog output of the air to fuel ratio from the Zeitronix Wideband sensor.

Serial Connection Pin Position	Signal Type
1	Injector
2	Throttle Position LO
3	Throttle Position HI
4	Air to Fuel Ratio Signal Output LO
5	Air to Fuel Ratio Signal Output HI

Table 4.12: Serial Connection Position

4.6 MatLab Code and System Status

The MATLAB® file to acquire data from the target machine was modified in order to list more information about the experiment being run. Information such as sample time (the overall sample time of the target machine), start time (the target machine starts), stop time (the target machine stops), number of log wraps (the number of times the target data buffer has wrapped over since the start of data acquisition), execution time (the amount of time since the task has started), and CPU overload (a value detected when a CPU overload occurs). Specific target object commands are used to get target machine state information and are seen Figure 4.29. The rest of the code is presented in the Appendix section of this report.

```
% Acquires the sample time of the target
sampletime=sg.sampletime;

% Number of times the buffer data wrapped over
numberofdatawraps=sg.numlogwraps;

% Amount of time since task was started
TET_Time=sg.ExecTime;

% Gives a value of 'detected' a CPU overload occurs
CPUoverload=sg.CPUoverload;

% The Average Time for one execution of the model
AverageExecution=sg.AvgTET;
```

Figure 4.29: Matlab Code for xPC Target Statuses

CHAPTER 5

ENGINE MAPS

Using the above mentioned data acquisition equipment engine maps will be created. The maps will include fuel injection timing, ignition timing, intake air mass flow into manifold, throttle behavior, volumetric efficiency, air to fuel ratio correlated with engine speed, manifold pressure and throttle angle.

5.1 Fuel Injection

The fuel injection timing is recorded from the current Engine Management System brand electronic control unit (ECU). This ECU is able to successfully keep the engine running. The purpose of collecting the injection timing is to learn what does work in order to duplicate on future ECU designs that are planned for later research. The fuel injection map will include the injection signal coming from the Engine Management System ECU, the current engine speed, intake manifold pressure, and engine crank angle.

5.2 Spark Timing

The spark timing was measured to get a nominal spark timing map. The current spark timing is being controlled mechanically by a magneto positioned next to the fly wheel. The fly wheel contains a magnet and as the fly wheel spins a charge is generated in the magneto that discharges at some angle. This map will include a representation of the spark signal, engine speed, and intake manifold pressure. The crank angle was measured to get the actual point when the spark fires relative to crank angle.

The engine testing was done by running the engine steady state conditions. The steady state condition was achieved by maintaining a constant throttle opening from 0° to 20° in 5° increments.

Changes in engine load are created by changing the resistance to the motor shaft turning. This resistance is created using a hydraulic dynamometer. The resistance is varied by restricting the flow going to the hydraulic pump. The pump is driven by the engine at a one to one gear ratio, therefore as the fluid flow is more restricted therefore the energy required to maintain a particular speed must increase. To maintain the idle speed of 1200 rpm at larger throttle openings the load must increase with the throttle angle.

CHAPTER 6

EXPERIMENTAL DATA

The data collected from experimental runs taking measurements of the crank angle, intake manifold pressure, intake mass air flow, injection, spark plug, throttle position, wideband O₂ sensor and air temperatures using thermocouples. The electrical signal recorded by the data acquisition system are converted into SI units. Data from the engine testing was plotted and processed using Matlab. Code used for this process is presented in Appendix C. Plots at a set point of 1200 rpm and 0 to 20 are presented in Figure 6.1 through Figure 6.5 for intake mass air flow plotted versus crank angle of gasoline. The maximum mass air flow and crank angle position are shown designated in the figures as well. At 1200 rpm and throttle percentage openings of 0, 5, 10, 15 and 20 percent open throttle the maximum intake air mass flow are 2.679×10^{-4} , 6.357×10^{-4} , 4.799×10^{-4} , 4.17×10^{-4} , and 3.163×10^{-4} kg/s at positions of 198.4, 4.3, 189.7, 239.5, 24.5 degrees respectively with respect to TDC at the 0 position. For E85 the same crank angle positions were used 2.465×10^{-4} , 2.594×10^{-4} , 2.312×10^{-4} , 4.855×10^{-4} , and 5.969×10^{-4} kg/s respectively and crank angle points of 145.7, 18.76, -6.493, 110.4, and 21.64 with respect to TDC at the 0 position. The Figure 6.6 through Figure 6.10 show plots from running E85 in the test engine.

The rest of the engine dynamic measurements are presented in Appendix C for set point measurements at 1500, 1800, 2100, 2400 rpm at throttle angles of 5°, 10°, 15°, 20° and 10°, 15°, and 20° and 10°, 15°, 20° respectively. The average of this data is presented in Table C.1 for E85 and Table C.2 for gasoline. The data listed in this section will be used in Section 7 the results section, to find the constants need for the engine model discussed in Section 3.

The data in Appendix C in Table C.1 and Table C.2 are listed with respect to the average speed at that the steady state engine measurement. The average speed ranges from 1187.35 rpm to 2453.77 rpm for E85 in Table C.1 with lowest intake mass air flow of 2.39E-04 to 5.27E-04 kg/s and intake manifold air pressure of 584.69 to 789.89 Pa. For Gasoline in Table C.2 the average speed ranges from 1235.85 to 2465.29 rpm, for intake mass air flow 2.70E-04 to 6.85E-04 kg/s for intake manifold pressure and 1333.76 to 1406.59 Pa. . Averaging was done at every crank angle point and the plotted versus 720 degrees of engine crank angle.

The expected changes of the intake manifold pressure and mass air flow with respect to changes in engine crank angel were not present in the collected data. The results were a mistake in the expected frequency of change. The Laminar Flow System is able to take measurements at measurement periods of up to every 0.1 seconds. The measurement period is set in program block Px701. The data can still be used to discern an average intake air mass flow and intake manifold pressure than can be used in creating a model.

The maximum mass air flow during intake was found as seen in Figure 6.1 through Figure 6.10 at set-points of 1200 rpm to 2400 rpm in steps and 0 percent throttle opening to 20 percent. The graphed data in the figure below reflects one portion of the engine cycles and is not averaged as done previously with the data in Appendix C.

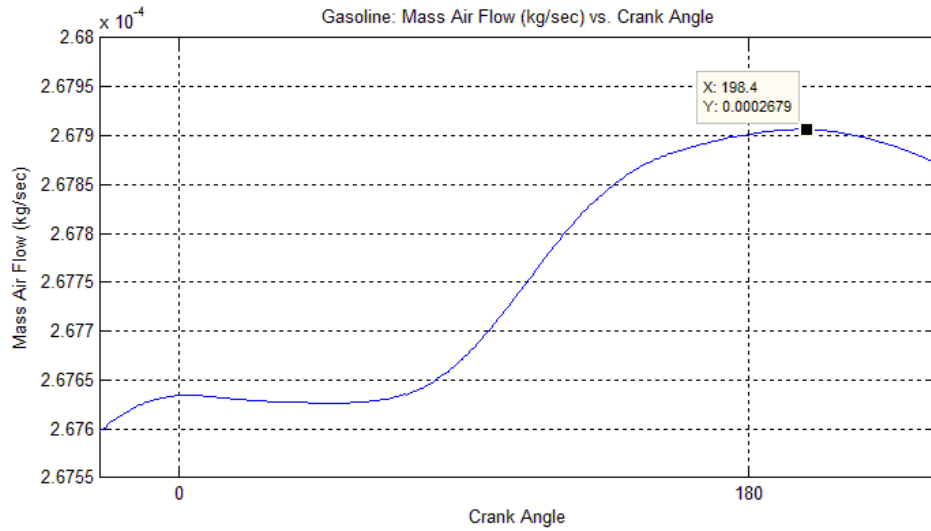

Figure 6.1: Gasoline: 1200 rpms at 0 Percent Open Throttle

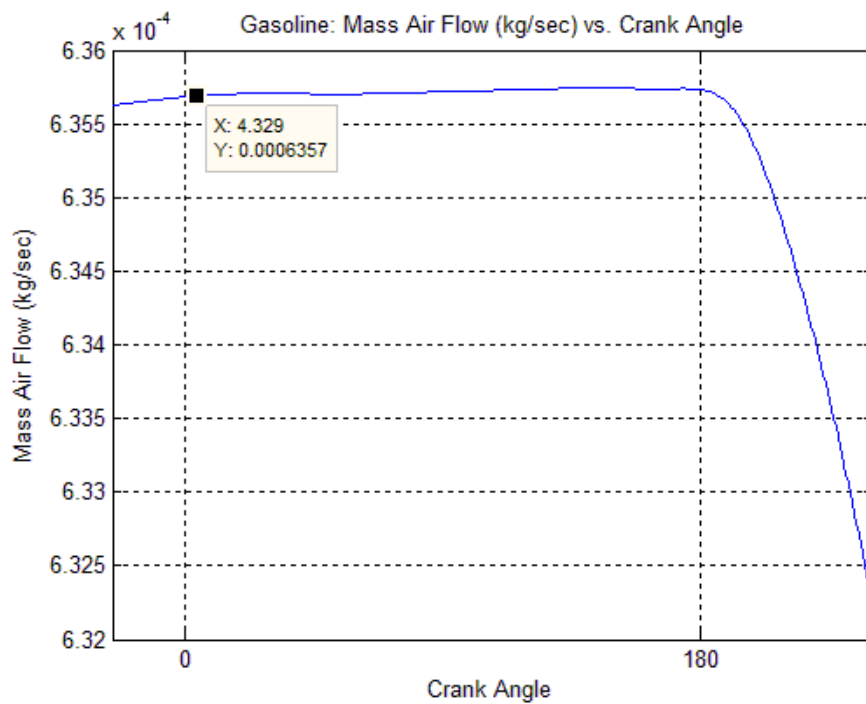

Figure 6.2: Gasoline: 1200 rpms at 5 Percent Open Throttle.

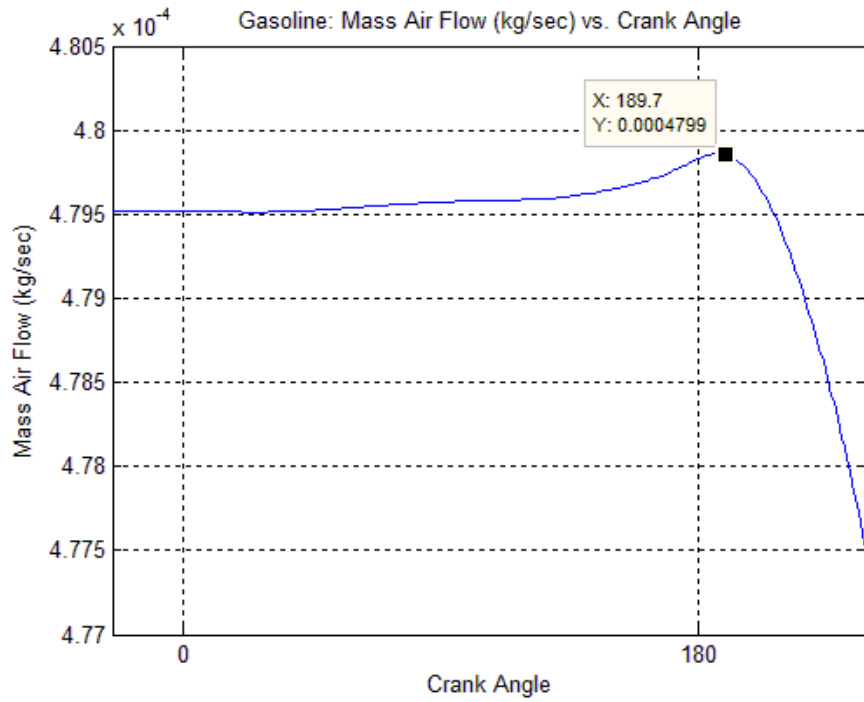

Figure 6.3: Gasoline: 1200 rpms at 10 Percent Open Throttle.

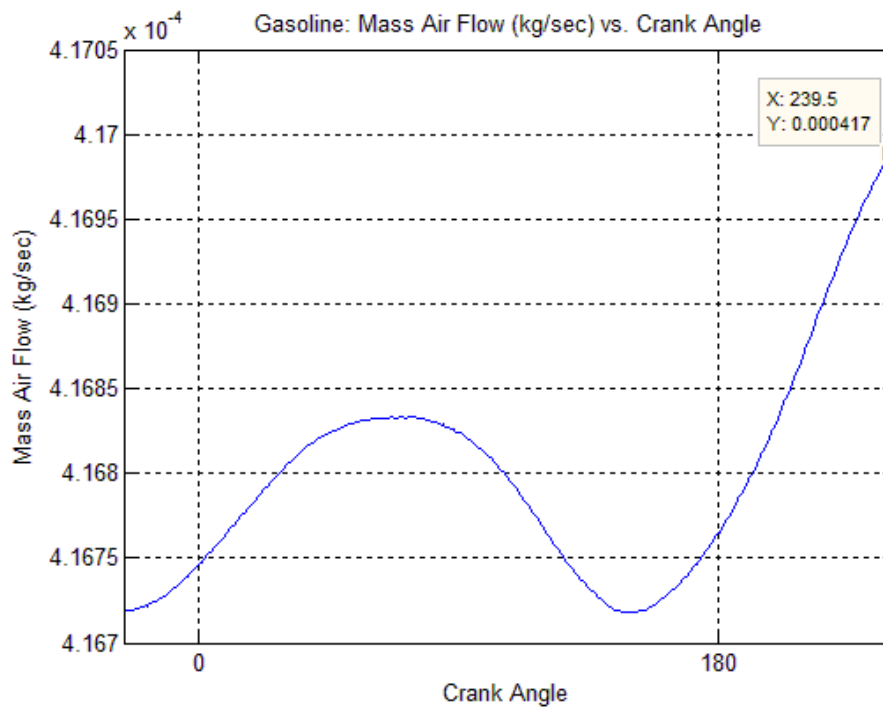

Figure 6.4: Gasoline: 1200 rpms at 15 Percent Open Throttle.

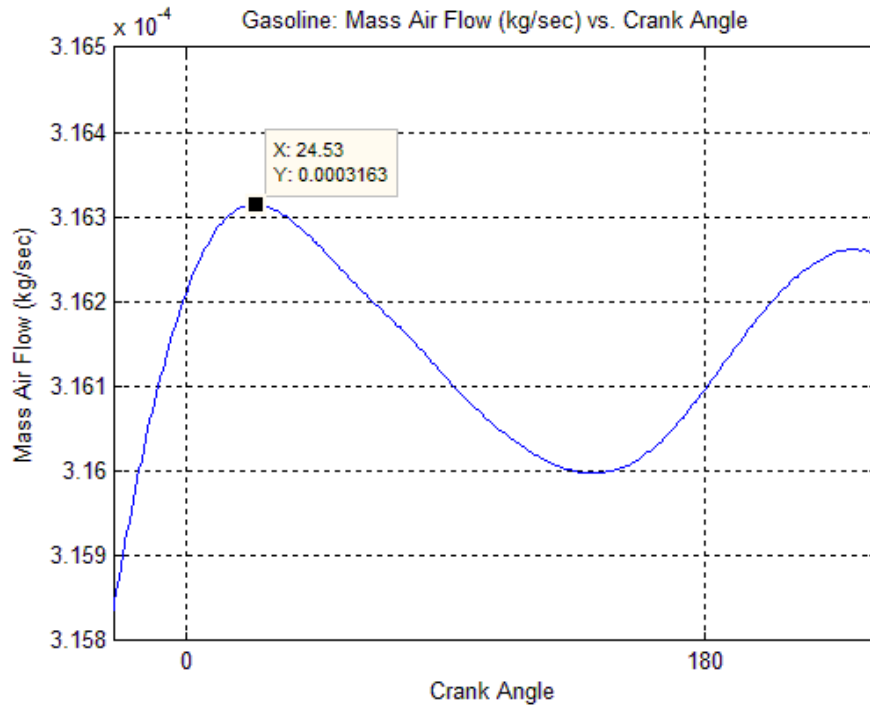

Figure 6.5: Gasoline: 1200 rpms at 20 Percent Open Throttle.

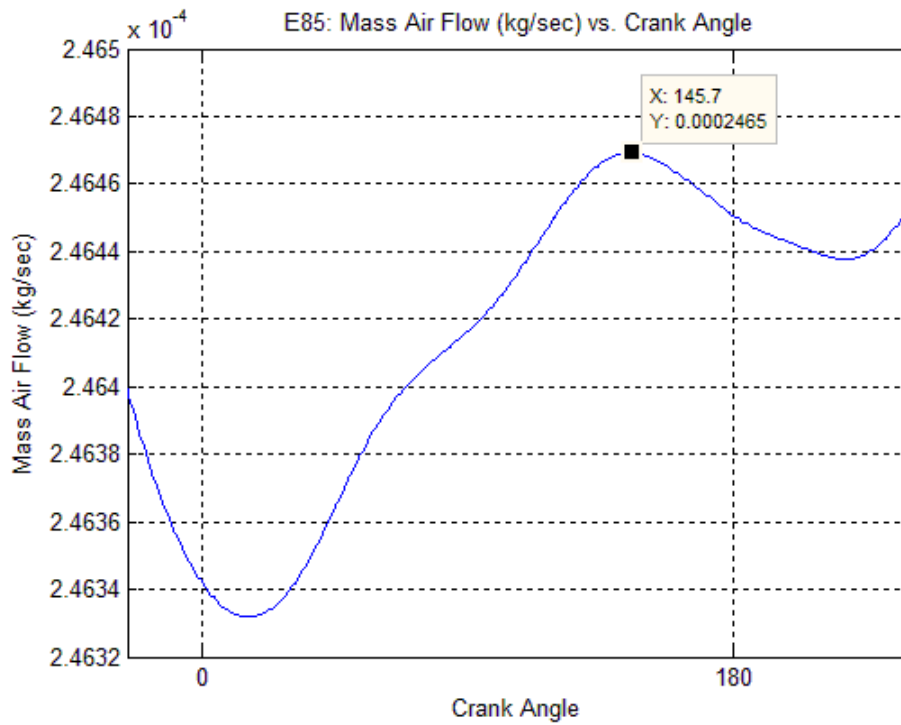

Figure 6.6: E85: 1200 rpms at 0 Percent Open Throttle.

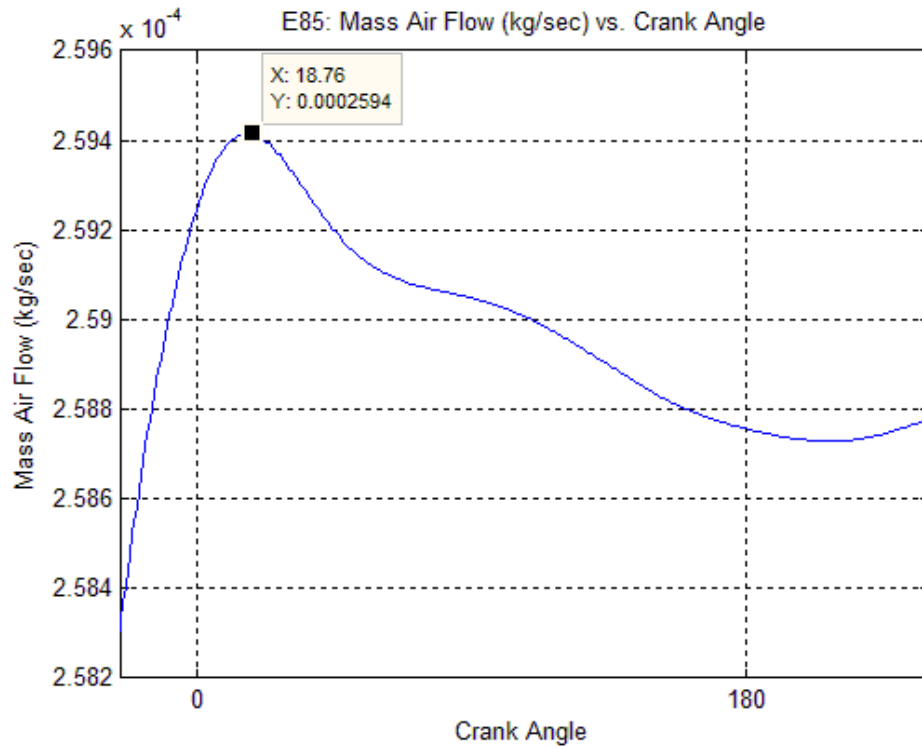

Figure 6.7: E85: 1200 rpms at 5 Percent Open Throttle.

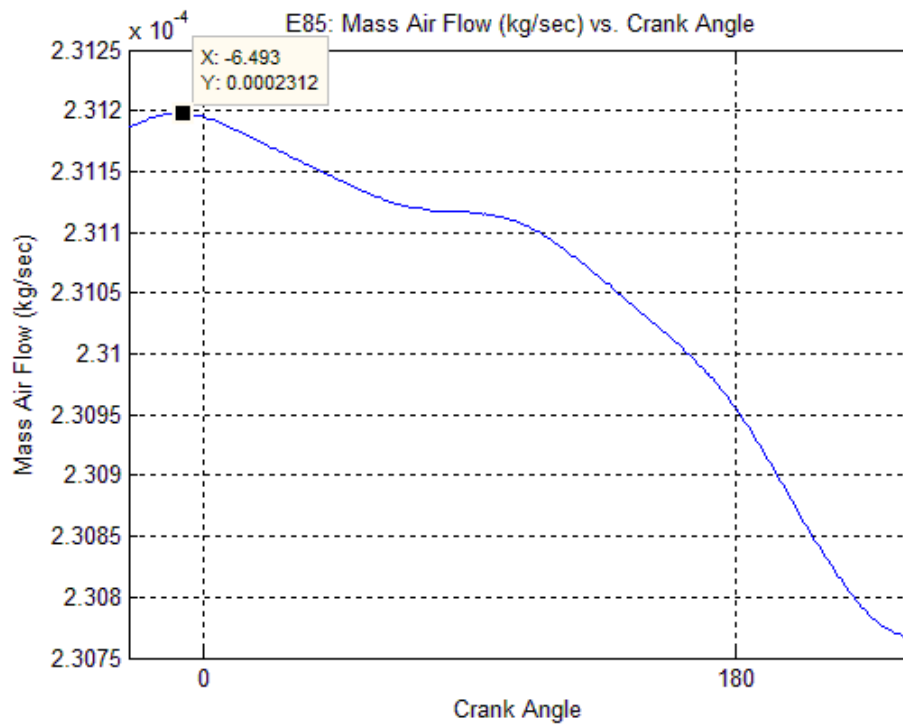

Figure 6.8: E85: 1200 rpms at 10 Percent Open Throttle.

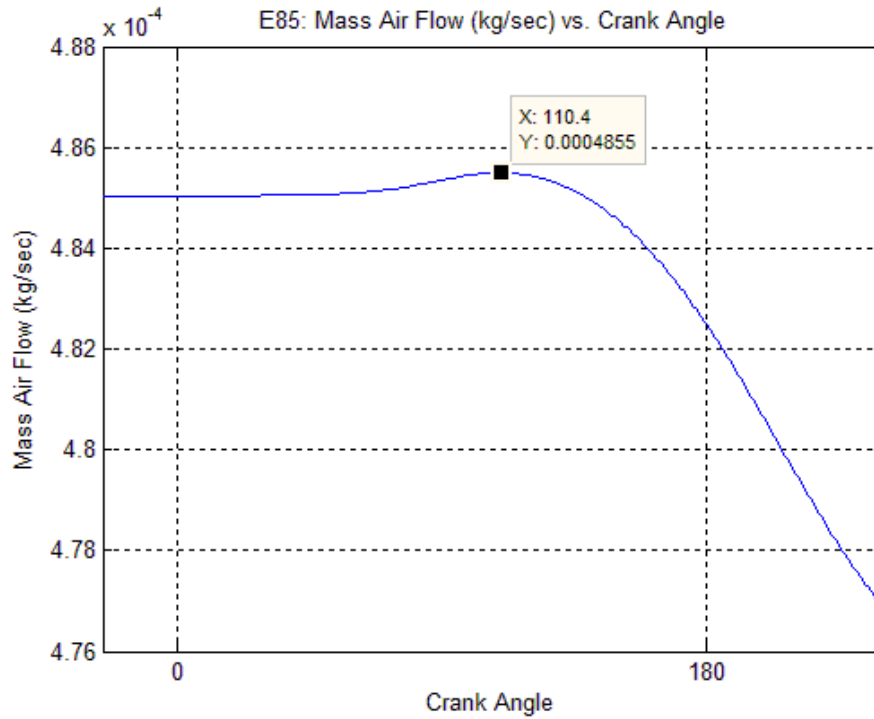

Figure 6.9: E85: 1200 rpms at 15 Percent Open Throttle.

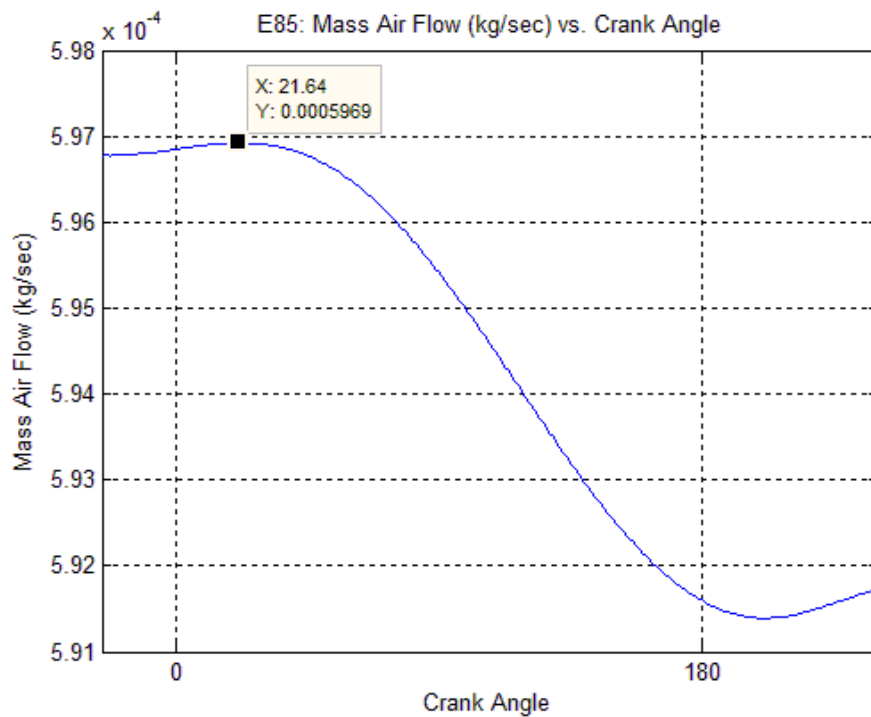

Figure 6.10: E85: 1200 rpms at 20 Percent Open Throttle.

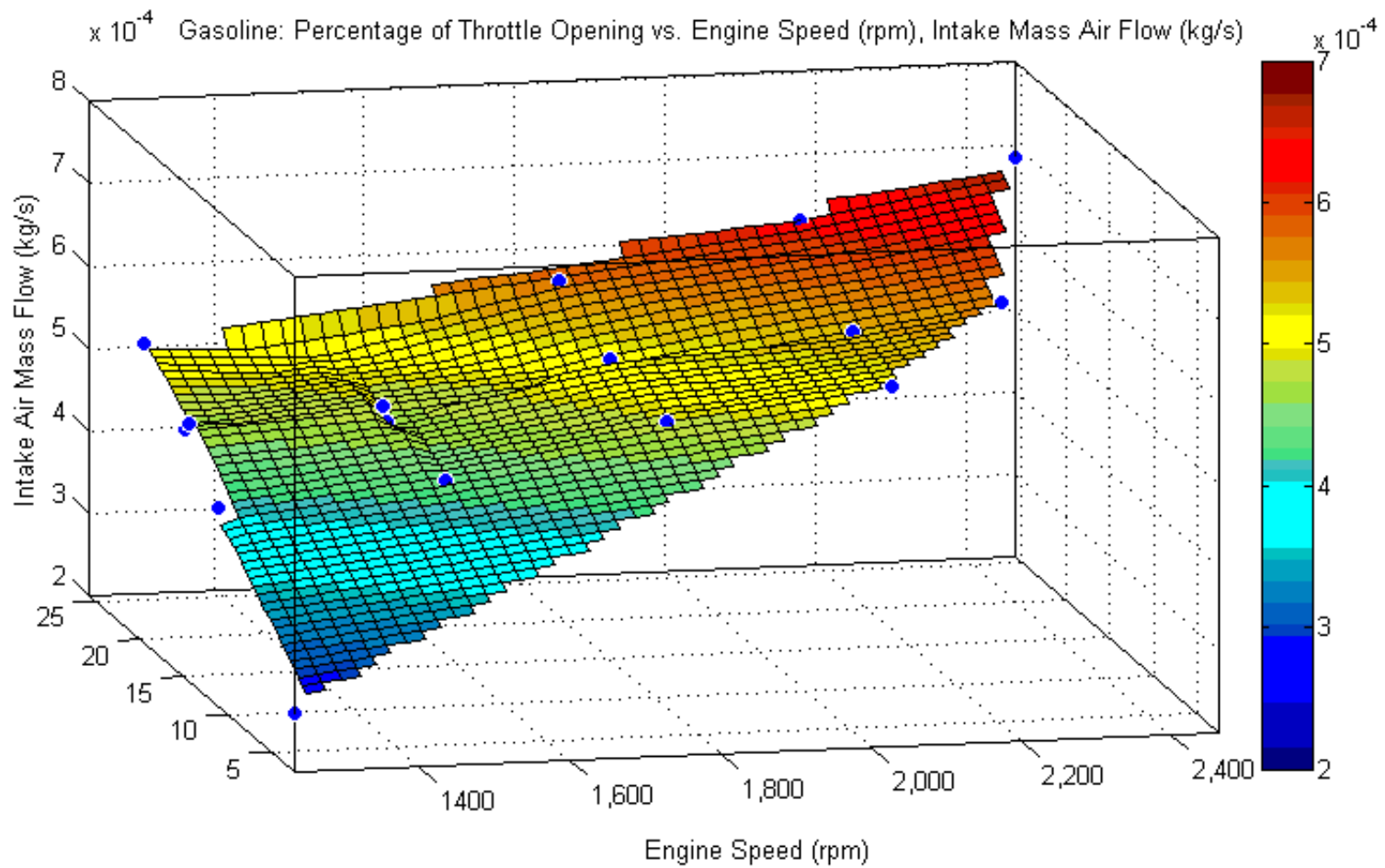

Figure 6.11: Gasoline: Contour Plot Engine Speed vs. Percentage of Throttle Opening and Intake Mass Air Flow

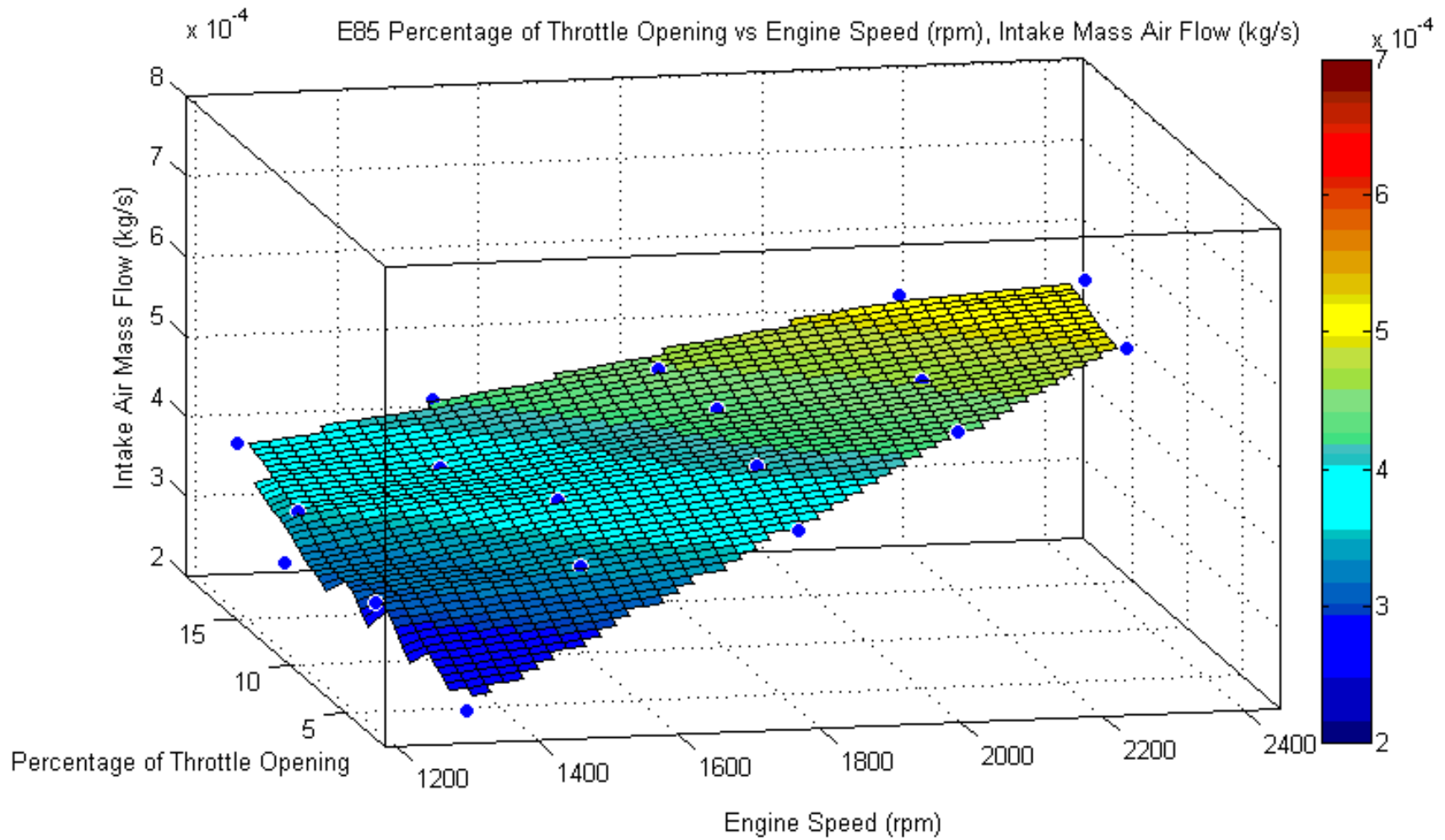

Figure 6.12: E85: Contour Plot Engine Speed vs. Percentage of Throttle Opening and Intake Mass Air Flow

CHAPTER 7

RESULTS

The estimation for the intake air mass flow was done using Equation (3.3) through Equation (3.6). The estimation ranges from 9.933×10^{-4} kg/s at closed throttle to 0.041 at 20% throttle opening.

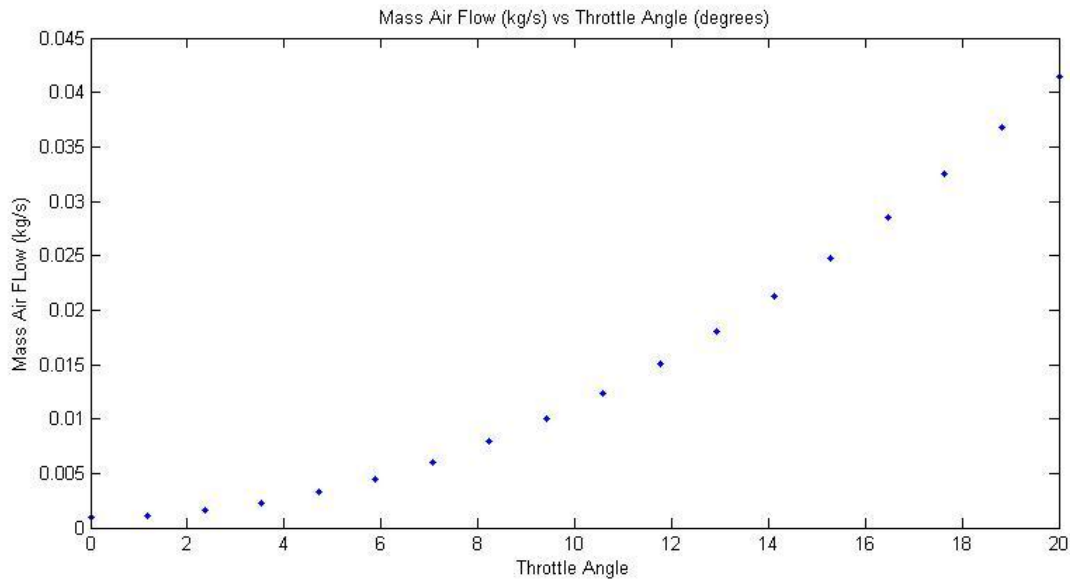

Figure 7.1: Estimation of Intake Air Mass Flow of Briggs and Stratton Engine

In order to characterize the engine, coefficients equations had to be determined using experimental means. Measurements were taken of the intake air mass flow, throttle angle, intake manifold pressure, and engine velocity. Using Equation (3.2) through Equation (3.11) for the mass air flow coefficient. The results of the system identification are found in Figure 7.2, Figure 7.3 and Table 7.1. The prediction made in Figure 7.2 and Figure 7.3 had to be adjusted creating a difference between the predictions. The adjustment was made by decreasing the throttle area leak ($A_{th_{leak}}$) value. This adjustment had to be made due to a previously unknown bend in the intake manifold.

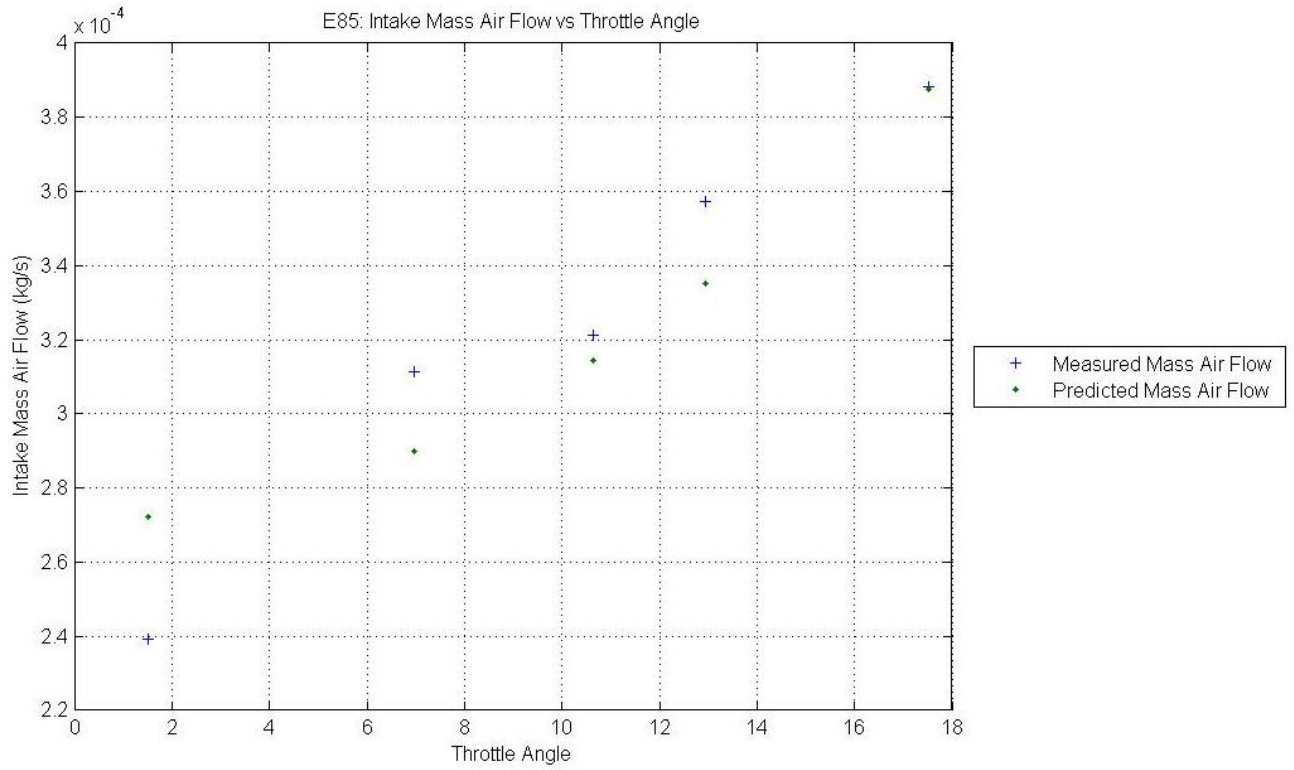

Figure 7.2: E85 Adjusted Predicted Intake Mass Air Flow

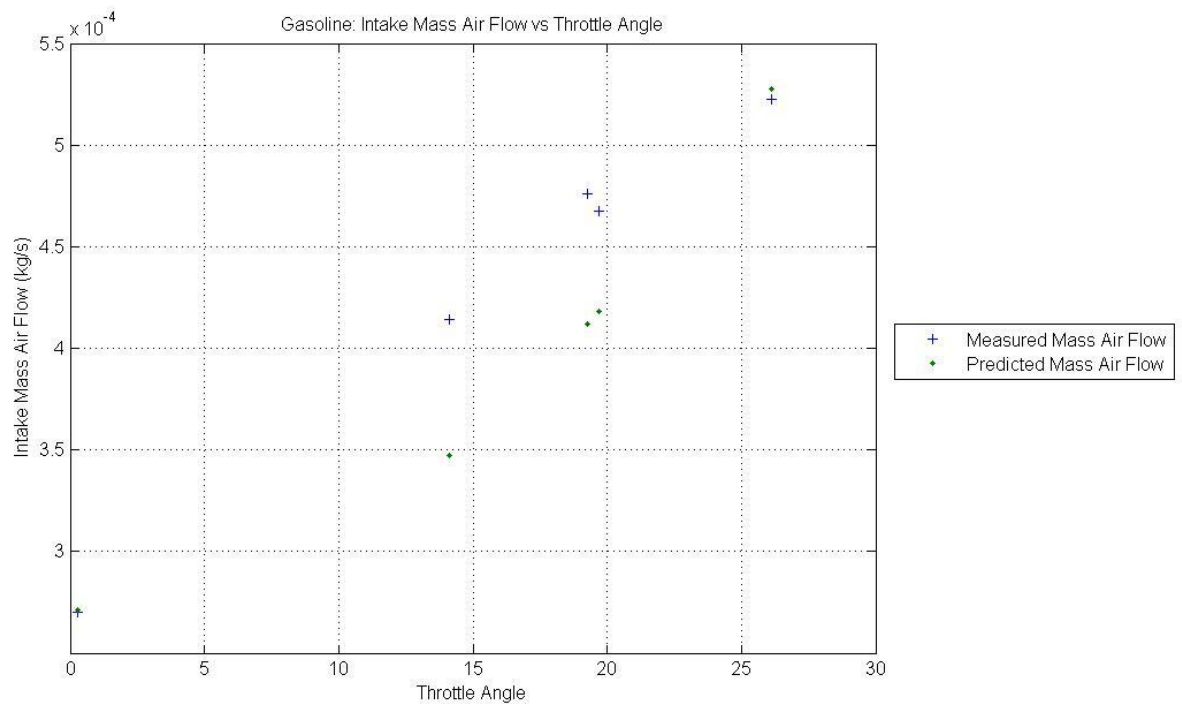

Figure 7.3: Gasoline Adjusted Predicted Intake Mass Air Flow

Coefficients	Fuel Type: E85	Fuel Type: Gasoline
Throttle Diameter d_{th}	3.58E-03	3.68E-03
Throttle Leak Area A_{thleak}	8.70E-07	8.70E-07
Coefficient 1 γ_0	2.62E+00	-5.55E-02
Coefficient 2 γ_1	-4.36E-03	2.45E-05
Coefficient 3 γ_2	1.79E-06	-4.15E-09
Williansparamter 1 η_0		
Williansparamter 2 η_1		
Williansparamter 3 β_0		
Williansparamter 4 β_2		

Table 7.1: Steady State Coefficients for Briggs and Stratton Engine

The engines throttle signal has become susceptible to repeated interference which is believed to be in sync with the injector signal. A plot of these two signals can be seen in

Figure 6.11 and

Figure 6.12. The interference is not major and does not conflict with the usability of the throttle signal. The repeatable noise can be seen to increase in frequency with respect to time and this is assumed that the noise is possibly produced by the injection signal or spark signal. Therefore with an increase in speed the frequency of the noise increase as seen in Figure 7.4 and Figure 7.7. The throttle angle signal is then plotted with respect to crank angle in Figure 7.6 at a set point of 1200 rpm and 0% throttle opening. The noise in the signal starts at 358.2 crank angle degrees and ends at 376.2 crank angle degrees. To show how the signal changes with engine speed the throttle signal is also plotted at 2400 rpm and 20% throttle opening. The set point is plotted as seen in Figure 7.7. Where the noise occurs at 359.6 crank angle degrees and 426.7 crank angle degrees. These two set points show idle and the extreme of the test points.

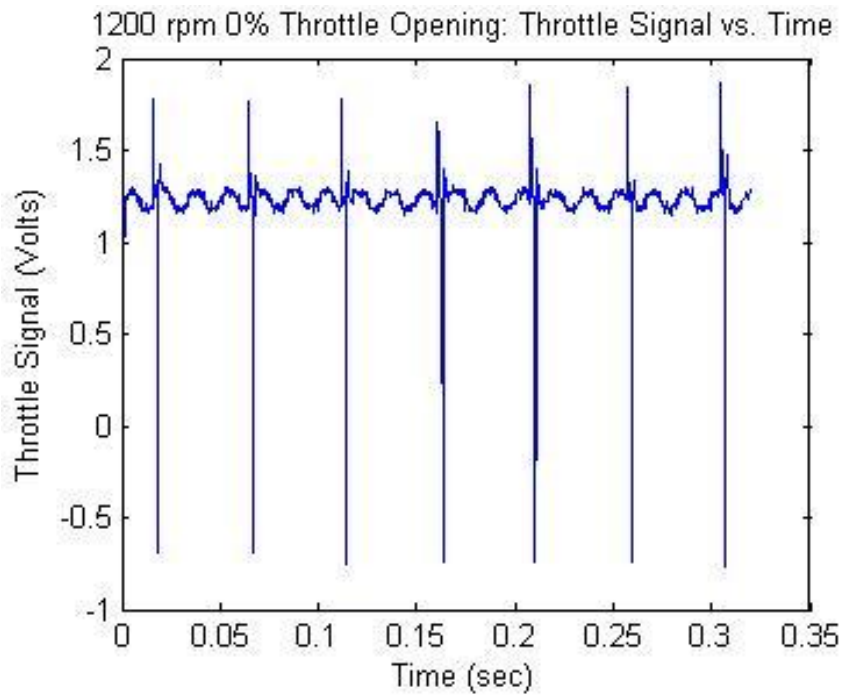

Figure 7.4: Throttle Angle Signal Versus Time at 1200 rpm

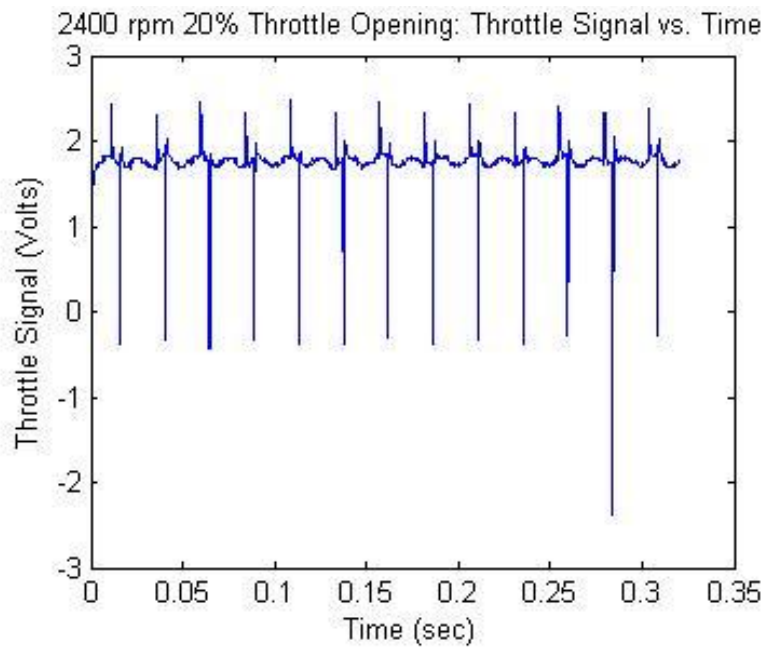

Figure 7.5: Throttle Angle Signal Versus Time at 2400 rpm

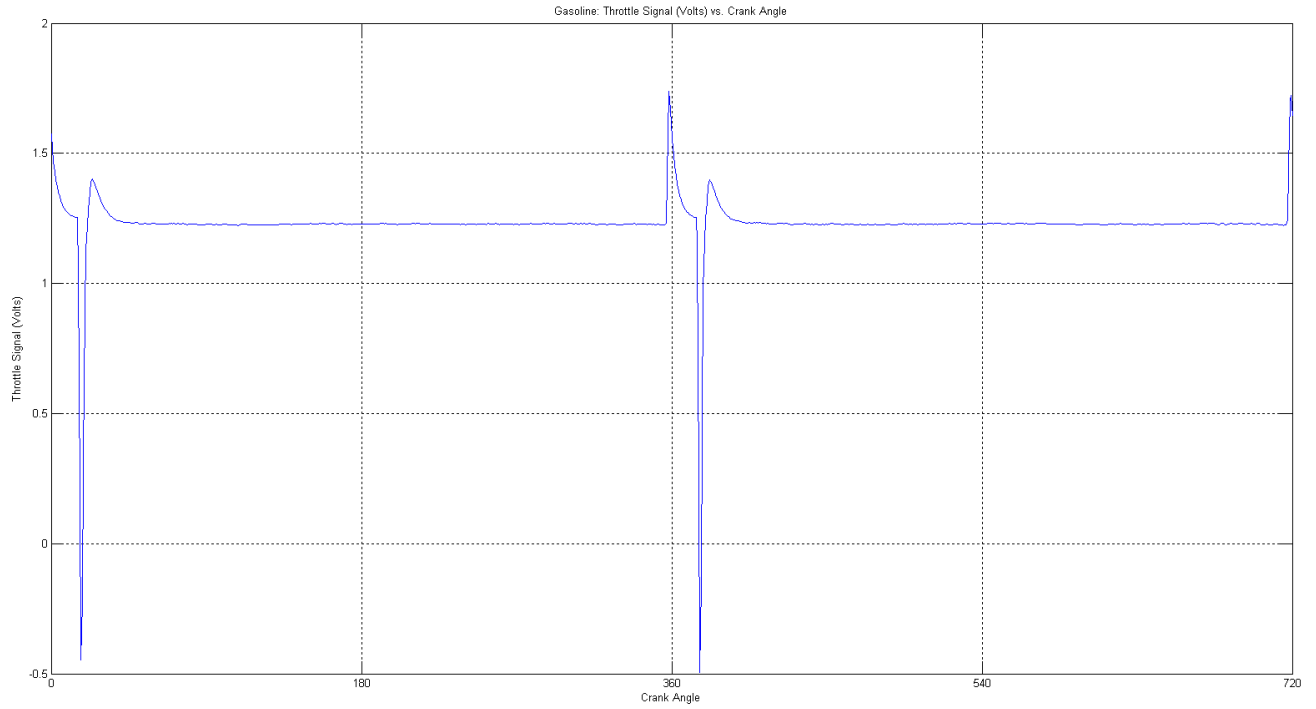

Figure 7.6: Throttle Angle Signal Versus Crank Angle at 1200 rpm and 0% Throttle Opening

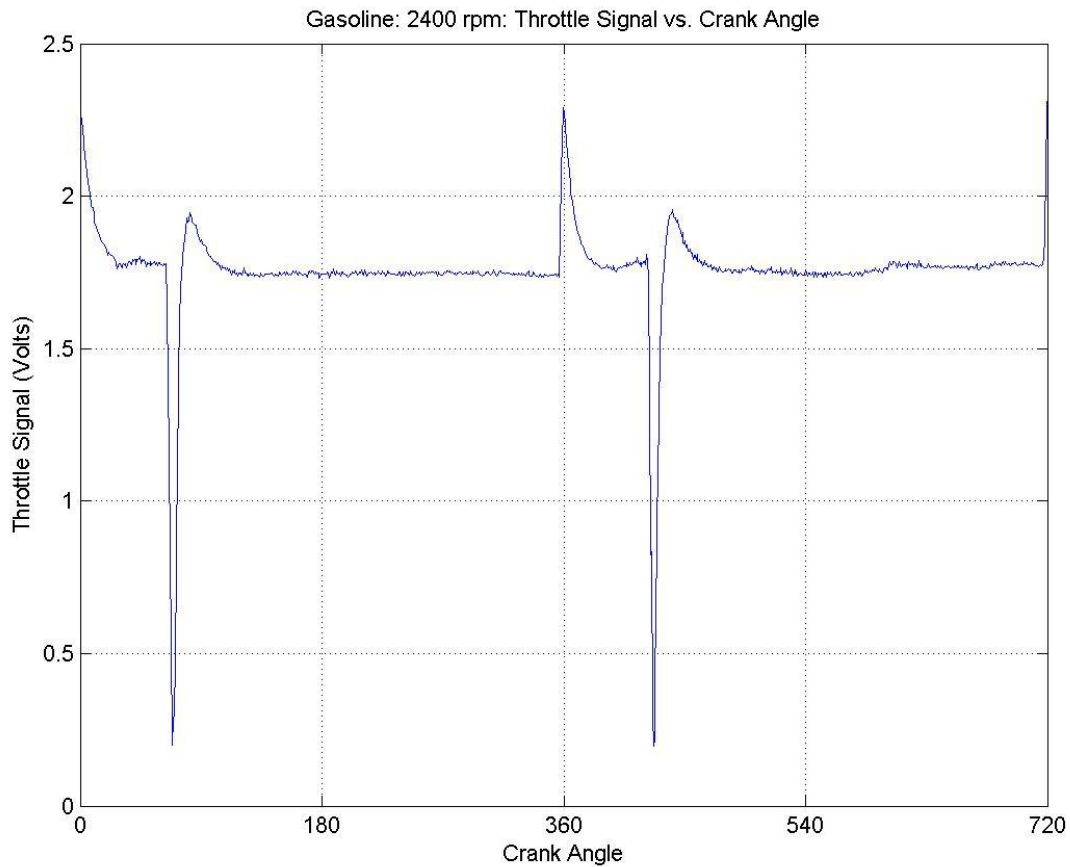

Figure 7.7: Throttle Angle Signal Versus Crank Angle at 2400 rpm and 20% Throttle Opening

The injector signal and spark ignition signal are plotted with respect to crank angle and time. This data can be used later for the initially design of the ECU. The data is presented in Table 7.2 through Table 7.5 for gasoline and Table 7.6 through Table 7.9 for E85. Where Table 7.2 is the average injection angle at each set point during the intake cycle for gasoline and Table 7.6 is the average injection angle for running under E85. Under gasoline the injection angle ranges form 18.85° at 0° throttle opening and 1200 rpm and 73.39° at 20% throttle opening and 2400 rpm. Data was also taken for the spark ignition signal as shown in Table 7.3 for gasoline engine test and Table 7.7 for E85 test. Running under gasoline the ignition angle ranges from 338.48° at 20% throttle angle and 1200 rpm to 343.68° at 15% throttle angle and 2400 rpm. The

current ECU also injects later during the engine cycle and that data will be presented in Appendix C. The duration of the injection timing high and low are presented in Table 7.4 and Table 7.5 respectively for gasoline and high and low under E85 in Table 7.8 and Table 7.9 respectively.

Percentage of Throttle Opening	1200 (rpm)	1500 (rpm)	1800 (rpm)	2100 (rpm)	2400 (rpm)
20	35	44	57	65	73
15	30	37	46	53	60
10	24	30	37	42	
5	23	31	37		
0	19				

Table 7.2: Gasoline: Average Injection Angle During Intake Stroke

Percentage of Throttle Opening	1200 (rpm)	1500 (rpm)	1800 (rpm)	2100 (rpm)	2400 (rpm)
20	338	340	341	342	343
15	339	339	341	342	344
10	339	340	341	342	
5	339	340	341		
0	339				

Table 7.3: Gasoline: Average Ignition Angle During Expansion Stroke

Percentage of Throttle Opening	1200 (rpm)	1500 (rpm)	1800 (rpm)	2100 (rpm)	2400 (rpm)
20	0.0043	0.0045	0.0041	0.0045	0.0045
15	0.0037	0.0039	0.0037	0.0037	0.0037
10	0.0031	0.0031	0.0031	0.0030	
5	0.0029	0.0030	0.0031		
0	0.0026				

Table 7.4: Gasoline: Average Low Injection Duration

Percentage of Throttle Opening	1200 (rpm)	1500 (rpm)	1800 (rpm)	2100 (rpm)	2400 (rpm)
20	0.0428	0.0348	0.0217	0.0230	0.0197
15	0.0432	0.0366	0.0284	0.0240	0.0212
10	0.0446	0.0365	0.0293	0.0248	
5	0.0460	0.0354	0.0294		
0	0.0494				

Table 7.5: Gasoline: Average High Injection Duration

Percentage of Throttle Opening	1200 (rpm)	1500 (rpm)	1800 (rpm)	2100 (rpm)	2400 (rpm)
20	45	52	55	63	64
15	43	47	51	55	60
10	33	42	44	49	
5	32	34	40		
0	23				

Table 7.6: E85: Average Injection Angle

Percentage of Throttle Opening	1200 (rpm)	1500 (rpm)	1800 (rpm)	2100 (rpm)	2400 (rpm)
20	338	340	341	342	343
15	340	340	341	342	343
10	339	340	341	342	
5	340	340	341		
0	339				

Table 7.7: E85: Average Ignition Angle

Percentage of Throttle Opening	1200 (rpm)	1500 (rpm)	1800 (rpm)	2100 (rpm)	2400 (rpm)
20	0.043592	0.034254	0.028046	0.023556	0.020921
15	0.041123	0.033073	0.028559	0.023945	0.021301
10	0.045381	0.035161	0.029589	0.024318	
5	0.043422	0.035684	0.029086		
0	0.04769				

Table 7.8: E85: High Average: Injection Duration in Seconds

Percentage of Throttle Opening	1200 (rpm)	1500 (rpm)	1800 (rpm)	2100 (rpm)	2400 (rpm)
20	0.005864	0.005286	0.004558	0.004497	0.004008
15	0.005154	0.004583	0.004284	0.003828	0.003801
10	0.004325	0.004263	0.003679	0.003477	
5	0.004035	0.003467	0.003314		
0	0.003049				

Table 7.9: E85: Low Average: Injection Duration in Seconds

CHAPTER 8

CONCLUSION

In conclusion the data acquisition system was able to measure the dynamics of the engine. Data such as mass air flow, intake manifold pressure, engine speed and crank angle, engine injection and ignition signals. Engine coefficients need to discern an accurate model could be determined using the data gathered with this system. Further, work will need to be done to determine all of the coefficients need for an accurate model. Engine model coefficients that require dynamic none steady statements need to be determined such as injection to top center transportation delay, engine inertia and volume of the intake manifold.

REFERENCES

- Environmental Protection Agency. (2008) Control of emissions from marine si and small si engines, vessels, and equipment final regulatory impact analysis. Retrieved from [http://www.epa.gov/oms/regs/nonroad/marinesi-equiold/420r08014.pdf\(EPA.gov\)](http://www.epa.gov/oms/regs/nonroad/marinesi-equiold/420r08014.pdf(EPA.gov))
- Bosch. (n.d.). Wideband A/F Oxygen Sensors. Retrieved June 13, 2011, from <http://www.boschautoparts.com/OxygenSensors/Pages/WidebandOxygenSensors.aspx>
- Grabner, P., Eichlseder, H., & Eckhard, G. (2010). *Potential of E85 Direct Injection for Passenger Car Application* (No. 2010-01-2086). Warrendale, PA: SAE International. Retrieved from <http://papers.sae.org/2010-01-2086/>
- Greene, A. B., & Lucas, G. G. (1969). *Testing of Internal Combustion Engines*. Hodder & Stoughton Ltd.
- Guzzella, L., & Onder, C. (2010). *Introduction to Modeling and Control of Internal Combustion Engine Systems* (1st ed.). Springer.
- Hendricks, E., & Sorenson, S. C. (1990). *Mean Value Modelling of Spark Ignition Engines* (No. 900616). Warrendale, PA: SAE International. Retrieved from <http://papers.sae.org/900616/>
- Herman, P., & Franchek, M. A. (2000). Engine idle speed control using actuator saturation. *Control Systems Technology, IEEE Transactions on*, 8(1), 192-199.
doi:10.1109/87.817704
- Heywood, J. (1988). *Internal Combustion Engine Fundamentals* (1st ed.). McGraw-Hill Science/Engineering/Math.

- Heywood, J. B. (1988). *Internal combustion engine fundamentals* / John B. Heywood. New York : McGraw-Hill Book Company. Retrieved from http://platon.serbi.ula.ve/librum/librum_ula/ver.php?ndoc=271732
- Jing Sun, Kolmanovsky, I., Cook, J. A., & Buckland, J. H. (2005). Modeling and control of automotive powertrain systems: a tutorial. *American Control Conference, 2005. Proceedings of the 2005* (pp. 3271-3283 vol. 5). Presented at the American Control Conference, 2005. Proceedings of the 2005. doi:10.1109/ACC.2005.1470476
- Kiencke, U., & Nielsen, L. (2010). *Automotive Control Systems: For Engine, Driveline, and Vehicle* (2nd ed.). Springer.
- LSU42.pdf. (n.d.). . Retrieved from <http://www.bosch-motorsport.com/pdf/sensors/lambda/LSU42.pdf>
- National Institute of Standards and Technology. (1995). ITS-90 Thermocouple Database, Web Version 2.0. *NIST ITS-90 Thermocouple Database*. Retrieved June 13, 2011, from <http://srdata.nist.gov/its90/main/>
- Rajamani, R. (2005). *Vehicle Dynamics and Control* (1st ed.). Springer.
- Rajamani, R. (2006). *Vehicle dynamics and control*. Birkhäuser.
- Varde, K. S., & Manoharan, N. K. (2009). *Characterization of Exhaust Emissions in a SI Engine using E85 and Cooled EGR* (No. 2009-01-1952). Warrendale, PA: SAE International. Retrieved from <http://papers.sae.org/2009-01-1952/>
- Wu, Yuh-Yih, Chen, Bo-Chiuan, Hsieh, Feng-Chi, Huang, M.-L., & Wu, Y.-H. (2006). *Development of Hardware-In-the-Loop Simulation for Scooter Engine Control* (No. 2006-01-0614). Warrendale, PA: SAE International. Retrieved from <http://papers.sae.org/2006-01-0614/>

Wu, Y-Y, Chen, B-C, & Hsieh, F-C. (2007). Modulization of four-stroke single-cylinder spark-ignition air-cooled engine models. *Proceedings of the Institution of Mechanical*

Engineers, Part D: Journal of Automobile Engineering, 221(8), 1015-1026.

doi:10.1243/09544070JAUTO184

Zeitronix. (2011). Zeitronix Software : Zeitronix Data Logger (ZDL) Updates, Screen Shots, 3rd Party Software. *Zeitronix: Wideband Engine Datalogging Systems and Accessories*.

Retrieved June 13, 2011, from <http://www.zeitronix.com/zdl/index.shtml#latest>

Measurement Computing Guide to Signal Connections www.mccdaq.com Revision 4 October, 2006

Matlab (R2010a) [High Level Computational language] Natick, Massachusetts :Mathworks, Inc.

<http://www.mathworks.com/>

xPC Target (4.3) [Rapid Prototyping Kernel] Natick, Massachusetts :Mathworks, Inc.

<http://www.mathworks.com/>

LabVIEW (2010) [Measurement Interface Software] Austin, TX :National Instruments

Corporation <http://www.ni.com/labview/>

APPENDICES

Appendix A LINEARIZATION

Idle Speed Linearize

These equations are from

$$A_{\alpha}(\alpha_{th}) = \frac{\pi d_{th}^2}{4} \cdot \left(1 - \frac{\cos \alpha_{th}}{\cos \alpha_{th,0}} \right) + A_{th,leak} \quad (A.1)$$

$$\alpha_{th} = \alpha_{th,0} + \left(\frac{\pi}{2} - \alpha_{th,0} \right) \cdot u_{\alpha} \quad (A.2)$$

Equation (A.1) was algebraically manipulated to separate the cosine with the α_{th} variable from the rest of the constants. Equation (A.2) was also inserted into Equation (A.1). The results can be seen in Equation (A.3).

$$A_{\alpha}(\alpha_{th}) = \frac{\pi d_{th}^2}{4} \left(1 - \frac{1}{\cos \alpha_{th,0}} \cdot \cos \left(\alpha_{th,0} + \left(\frac{\pi}{2} - \alpha_{th,0} \right) \cdot u_{\alpha} \right) \right) + A_{th,leak} \quad (A.3)$$

Next, Equation (A.3) was substituted into Equation (A.5) The results can be seen in Equation (A.5).

$$\dot{m}_{\alpha}(t) = A_{\alpha}(t) \frac{p_{\alpha}}{\sqrt{R\vartheta_{\alpha}}} \frac{1}{\sqrt{2}} \quad (A.4)$$

$$\dot{m}_{\alpha}(t) = \frac{p_{\alpha}}{\sqrt{R\vartheta_{\alpha}}} \cdot \frac{1}{\sqrt{2}} \cdot \left(\frac{\pi d_{th}^2}{4} \left(1 - \frac{1}{\cos \alpha_{th,0}} \cdot \cos \left(\alpha_{th,0} + \left(\frac{\pi}{2} - \alpha_{th,0} \right) \cdot u_{\alpha} \right) \right) + A_{th,leak} \right) \quad (A.5)$$

A Maclaurin Equation (A.6) series approximation was then used for the cosine function in Equation (A.5) as seen below in Equation (A.6) and Equation (A.7). With the substitution in

Equation (A.6) there is an error difference between the right and left hand side of the equation.

The percent difference is 4.17E-08% with no input signal and at wide open throttle the error is

3.82E+17 % which is unacceptable. Assuming the throttle will only open at a maximum of 30%

the error is 0.24 %.

$$\cos x = 1 - \frac{1}{2}x^2 \quad (\text{A.6})$$

$$x = \alpha_{th,0} + \left(\frac{\pi}{2} - \alpha_{th,0}\right) \cdot u_\alpha \quad (\text{A.7})$$

$$x^2 = \alpha_{th,0}^2 + \alpha_{th,0}^2 u_\alpha^2 - 2\alpha_{th,0}^2 u_\alpha + \pi\alpha_{th,0}u_\alpha + \pi\alpha_{th,0}u_\alpha^2 + \frac{\pi^2}{4}u_\alpha^2 \quad (\text{A.8})$$

$$\begin{aligned} & \cos\left(\alpha_{th,0} + \left(\frac{\pi}{2} - \alpha_{th,0}\right) \cdot u_\alpha\right) \\ &= 1 - \frac{1}{2}\left(\alpha_{th,0}^2 + \alpha_{th,0}^2 u_\alpha^2 - 2\alpha_{th,0}^2 u_\alpha + \pi\alpha_{th,0}u_\alpha + \pi\alpha_{th,0}u_\alpha^2 + \frac{\pi^2}{4}u_\alpha^2\right) \end{aligned} \quad (\text{A.9})$$

Then the cosine function is linearized because of the u_α^2 term as seen in Equation (A.10) Equation (A.11).

$$\dot{m}_\alpha(t) = \frac{p_\alpha}{\sqrt{R\vartheta_\alpha}} \cdot \frac{1}{\sqrt{2}} \cdot \left(\frac{\pi d_{th}^2}{4}\right) \quad (\text{A.10})$$

$$- \frac{\pi d_{th}^2}{4 \cos \alpha_{th,0}} \left(1 - \frac{1}{2}\left(\alpha_{th,0}^2 + \alpha_{th,0}^2 u_\alpha^2 - 2\alpha_{th,0}^2 u_\alpha + \pi\alpha_{th,0}u_\alpha + \pi\alpha_{th,0}u_\alpha^2 + \frac{\pi^2}{4}u_\alpha^2\right)\right) + A$$

$$\begin{aligned} & \frac{\partial f(\dot{m}_\alpha(t))}{\partial u_\alpha} = \frac{p_\alpha}{\sqrt{R\vartheta_\alpha}} \cdot \frac{1}{\sqrt{2}} \\ & \cdot \frac{\pi d_{th}^2}{8 \cdot \cos \alpha_{th,0}} \left(0 + 2\alpha_{th,0}^2 u_\alpha - 2\alpha_{th,0}^2 + \pi\alpha_{th,0} + 2\pi\alpha_{th,0}u_\alpha + \frac{\pi^2}{2}u_\alpha\right) \end{aligned} \quad (\text{A.11})$$

This equation simplifies into

$$\frac{\partial f(\dot{m}_\alpha(t))}{\partial u_\alpha} = \frac{p_\alpha}{\sqrt{R\vartheta_\alpha}} \frac{1}{\sqrt{2}} \frac{\pi d_{th}^2}{8 \cos \alpha_{th,0}} \left(2\pi \alpha_{th,0} u_\alpha + 2\alpha_{th,0}^2 u_\alpha + \frac{\pi^2}{2} u_\alpha - 2\alpha_{th,0}^2 + \pi \alpha_{th,0} \right) \quad (\text{A.12})$$

Then Equations (A.15) and Equation (A.16) were substituted into Equation (A.14) then the results were placed in Equation (A.13) The results of these multiplications can be seen in Equation (A.17).

$$\dot{m}_e(t) = \frac{p_m(t)}{R\vartheta_m(t)} \cdot \lambda_l(\omega_e(t), p_m(t)) \cdot V_d \cdot \frac{\omega_e(t)}{4\pi} \quad (\text{A.13})$$

$$\lambda_l(\omega_e(t), p_m(t)) = \lambda_{l\omega}(\omega_e(t)) \cdot \lambda_{lp}(p_m(t)) \quad (\text{A.14})$$

$$\lambda_{l\omega}(\omega_e(t)) = \gamma_0 + \gamma_1 \cdot \omega_e + \gamma_2 \cdot \omega_e^2 \quad (\text{A.15})$$

$$\lambda_{lp}(p_m(t)) = \frac{V_c + V_d}{V_d} - \frac{V_c}{V_d} \cdot \left(\frac{p_e}{p_m(t)} \right)^{1/k} \quad (\text{A.16})$$

$$\dot{m}_e(t) = \frac{p_m(t)}{R\vartheta_m(t)} \cdot (\gamma_0 + \gamma_1 \cdot \omega_e + \gamma_2 \cdot \omega_e^2) \cdot \left(\frac{V_c + V_d}{V_d} - \frac{V_c}{V_d} \cdot \left(\frac{p_e}{p_m(t)} \right)^{1/k} \right) \cdot V_d \cdot \frac{\omega_e(t)}{4\pi} \quad (\text{A.17})$$

Then Equation (A.15) and Equation (A.16) was distributed throughout Equation (A.14) through Equation (A.21)

$$\dot{m}_e(t) = \frac{p_m(t)}{R\vartheta_m(t)} \cdot V_d \cdot \frac{\omega_e(t)}{4\pi} \cdot \left[\frac{V_c + V_d}{V_d} \cdot (\gamma_0 + \gamma_1 \cdot \omega_e + \gamma_2 \cdot \omega_e^2) - \frac{V_c}{V_d} \cdot \left(\frac{p_e}{p_m(t)} \right)^{\frac{1}{k}} \cdot (\gamma_0 + \gamma_1 \cdot \omega_e + \gamma_2 \cdot \omega_e^2) \right] \quad (\text{A.18})$$

The p_e (exhaust manifold pressure) divide by $p_m(t)$ (manifold pressure) to the $1/k$ power was separated to get the manifold pressure alone. Then p_m and ω_e (engine speed) were distributed as necessary as seen blow. Equation (A.27) through Equation (A.30) was then algebraically manipulated to see effects of state spaces variable upon each other.

$$\dot{m}_e(t) = \frac{V_d}{R\vartheta_m(t)4\pi} \quad (\text{A.19})$$

$$\cdot \left[\frac{V_c + V_d}{V_d} \cdot (\gamma_0 \cdot \omega_e \cdot p_m + \gamma_1 \cdot \omega_e^2 \cdot p_m + \gamma_2 \cdot \omega_e^3 \cdot p_m) \right]$$

$$\cdot \left[-\frac{p_e^{\frac{1}{k}} \cdot V_c}{V_d} \cdot p_m^{\frac{k}{k}} \cdot \left(\frac{1}{p_m(t)} \right)^{\frac{1}{k}} \cdot (\gamma_0 \omega_e + \gamma_1 \omega_e^2 + \gamma_2 \cdot \omega_e^3) \right]$$

Next, the $p_m^{k/k}$ term and $\left(\frac{1}{p_m(t)} \right)^{\frac{1}{k}}$ are multiplied to result as seen in Equation (A.20).

$$p_m^{k/k} \cdot \left(\frac{1}{p_m(t)} \right)^{\frac{1}{k}} = p_m^{\frac{k-1}{k}} \quad (\text{A.20})$$

This results in Equation (A.21).

$$\dot{m}_e(t) = \frac{V_d}{R\vartheta_m(t)4\pi} \quad (\text{A.21})$$

$$\cdot \left[\frac{V_c + V_d}{V_d} \cdot p_m \cdot (\gamma_0 \cdot \omega_e + \gamma_1 \cdot \omega_e^2 + \gamma_2 \cdot \omega_e^3) - \frac{p_e^{\frac{1}{k}} \cdot V_c}{V_d} \cdot p_m^{\frac{k-1}{k}} \right]$$

$$\cdot (\gamma_0 \omega_e + \gamma_1 \omega_e^2 + \gamma_2 \cdot \omega_e^3)$$

The above equation was then inserted into Equation (A.22)

$$\dot{m}_\beta(t) = \frac{\dot{m}_e(t)}{1 + 1/(\lambda\sigma_0)} \quad (\text{A.22})$$

The results are seen below.

$$\dot{m}_\beta(t) = \frac{1}{1 + \frac{1}{(\lambda\sigma_0)}} \cdot \frac{V_d}{R\vartheta_m(t)4\pi} \cdot \left[\begin{array}{l} \frac{V_c + V_d}{V_d} \cdot p_m \cdot (\gamma_0 \cdot \omega_e + \gamma_1 \cdot \omega_e^2 + \gamma_2 \cdot \omega_e^3) \\ - \frac{p_e^{\frac{1}{k}} \cdot V_c}{V_d} \cdot p_m^{\frac{k-1}{k}} \cdot (\gamma_0 \omega_e + \gamma_1 \omega_e^2 + \gamma_2 \cdot \omega_e^3) \end{array} \right] \quad (\text{A.23})$$

Then the above equation was linearize by taking partial derivatives with respect to the manifold pressure p_m and then the engine speed ω_e . The results can be seen in Equation (A.24) and Equation (A.25).

$$\frac{\partial f(\dot{m}_\beta(t))}{\partial p_m} = \frac{1}{1 + \frac{1}{(\lambda\sigma_0)}} \cdot \frac{V_d}{R\vartheta_m(t)4\pi} \cdot \left[\begin{array}{l} \frac{V_c + V_d}{V_d} \cdot (\gamma_0 \cdot \omega_e + \gamma_1 \cdot \omega_e^2 + \gamma_2 \cdot \omega_e^3) \\ - \frac{p_e^{\frac{1}{k}} \cdot V_c}{V_d} \cdot \frac{k-1}{k} \cdot p_m^{\frac{-1}{k}} \cdot (\gamma_0 \omega_e + \gamma_1 \omega_e^2 + \gamma_2 \cdot \omega_e^3) \end{array} \right] \quad (\text{A.24})$$

$$\frac{\partial f(\dot{m}_\beta(t))}{\partial \omega_e} = \frac{1}{1 + \frac{1}{(\lambda\sigma_0)}} \cdot \frac{V_d}{R\vartheta_m(t)4\pi} \cdot \left[\begin{array}{l} \frac{V_c + V_d}{V_d} \cdot p_m \cdot (\gamma_0 + \gamma_1 \cdot 2\omega_e + \gamma_2 \cdot 3\omega_e^2) - \frac{p_e^{\frac{1}{k}} \cdot V_c}{V_d} \cdot p_m^{\frac{k-1}{k}} \\ \cdot (\gamma_0 + \gamma_1 \cdot 2\omega_e + \gamma_2 \cdot 3\omega_e^2) \end{array} \right] \quad (\text{A.25})$$

Then the two Equation (A.24) and Equation (A.25) are linearized about engine manifold pressure and engine speed set points. The results of the linearization are the placed into the Equation (A.26)

$$\frac{d}{dt} p_m(t) = \frac{R \cdot \vartheta_m}{V_m} \cdot [\dot{m}_\alpha(t) - \dot{m}_\beta(t)] \quad (\text{A.26})$$

Next, the engine torque equation is linearized using the Equations (A.27) through Equation (A.31)

$$T_e(t) = (e \cdot p_{m\varphi} - p_{me0f} - p_{me0g}) \cdot \frac{V_d}{4\pi} \quad (\text{A.27})$$

$$e \cdot p_{m\varphi} = (\eta_0 + \eta_1 \cdot \omega_e) \cdot H_l \cdot \frac{\dot{m}_\beta \cdot 4\pi}{\lambda \cdot \sigma_0 \cdot \omega_e \cdot V_d} \quad (\text{A.28})$$

$$p_{me0f} = (\beta_0 + \beta_2 \cdot \omega_e^2) \cdot \frac{4\pi}{V_d} \quad (\text{A.29})$$

$$p_{me0g} = p_{exhaust} - p_m \quad (\text{A.30})$$

The engine torque equation fully expanded is shown in the Equation (A.31).

$$T_e(t) = \left((\eta_0 + \eta_1 \cdot \omega_e) \cdot H_l \cdot \frac{\dot{m}_\beta \cdot 4\pi}{\lambda \cdot \sigma_0 \cdot \omega_e \cdot V_d} - (\beta_0 + \beta_2 \cdot \omega_e^2) \cdot \frac{4\pi}{V_d} - (p_e - p_m) \right) \cdot \frac{V_d}{4\pi} \quad (\text{A.31})$$

Next, \dot{m}_β is replaced with its represented equation. The results are seen in Equation (A.32).

$$T_e(t) = \tag{A.32}$$

$$\left((\eta_0 + \eta_1 \cdot \omega_e) \cdot H_l \right.$$

$$\cdot \frac{4\pi}{\lambda \cdot \sigma_0 \cdot \omega_e \cdot V_d} \left(\frac{1}{1 + \frac{1}{(\lambda \sigma_0)}} \cdot \frac{V_d}{R \vartheta_m(t) 4\pi} \right.$$

$$\cdot \left[\frac{V_c + V_d}{V_d} \cdot p_m \cdot (\gamma_0 \cdot \omega_e + \gamma_1 \cdot \omega_e^2 + \gamma_2 \cdot \omega_e^3) - \frac{p_e^{\frac{1}{k}} \cdot V_c}{V_d} \cdot p_m^{\frac{k-1}{k}} \right.$$

$$\cdot (\gamma_0 \omega_e + \gamma_1 \omega_e^2 + \gamma_2 \cdot \omega_e^3) \left. \right] - (\beta_0 + \beta_2 \cdot \omega_e^2) \cdot \frac{4\pi}{V_d}$$

$$\left. - (p_{exhaust} - p_m) \right) \cdot \frac{V_d}{4\pi}$$

The engine volume over four times pi is distributed and the equation is simplified and values distributed as necessary.

$$T_e(t) = \tag{A.33}$$

$$\left(\frac{(\eta_0 + \eta_1 \cdot \omega_e) \cdot H_l \cdot V_d}{\lambda \cdot \sigma_0 \cdot \omega_e \cdot R \cdot \vartheta_m(t) \cdot 4\pi \left(1 + \frac{1}{(\lambda \sigma_0)}\right)} \right.$$

$$\left. \left(\left[\frac{V_c + V_d}{V_d} \cdot p_m \cdot (\gamma_0 \cdot \omega_e + \gamma_1 \cdot \omega_e^2 + \gamma_2 \cdot \omega_e^3) - \frac{p_e^{\frac{1}{k}} \cdot V_c}{V_d} \cdot p_m^{\frac{k-1}{k}} \cdot (\gamma_0 \omega_e + \gamma_1 \omega_e^2 + \gamma_2 \cdot \omega_e^3) \right] - (\beta_0 + \beta_2 \cdot \omega_e^2) \cdot \frac{4\pi}{V_d} \right. \right.$$

$$\left. \left. - (p_{exhaust} - p_m) \right) \cdot \frac{V_d}{4\pi} \right)$$

The terms $(\eta_0 + \eta_1 \cdot \omega_e)$ and $\frac{1}{\omega_e}$ are distributed thru the equation as seen in Equation (A.34).

$$T_e(t) = \left(\frac{H_l \cdot V_d}{\lambda \cdot \sigma_0 \cdot R \cdot \vartheta_m(t) \cdot 4\pi \left(1 + \frac{1}{(\lambda \sigma_0)}\right)} \left(\left[\frac{V_c + V_d}{V_d} \cdot p_m \cdot (\eta_0 + \eta_1 \cdot \omega_e) \right. \right. \right. \quad (\text{A.34})$$

$$\cdot (\gamma_0 + \gamma_1 \cdot \omega_e + \gamma_2 \cdot \omega_e^2) - \frac{p_e^{\frac{1}{k}} \cdot V_c}{V_d} \cdot p_m^{\frac{k-1}{k}} \cdot (\eta_0 + \eta_1 \cdot \omega_e)$$

$$\left. \left. \left. \cdot (\gamma_0 + \gamma_1 \omega_e + \gamma_2 \cdot \omega_e^2) \right] \right) - (\beta_0 + \beta_2 \cdot \omega_e^2) - (p_{exhaust} - p_m) \cdot \frac{V_d}{4\pi} \right)$$

The torque equation was then inserted into the engine inertia equation as seen in Equation (A.36).

$$\frac{d}{dt} \omega_e(t) = \frac{1}{\Theta_e} [T_e(t) - T_l(t)] \quad (\text{A.35})$$

$$\frac{d}{dt} \omega_e(t) = \frac{1}{\Theta_e} \left[\left(\frac{H_l \cdot V_d}{\lambda \cdot \sigma_0 \cdot R \cdot \vartheta_m(t) \cdot 4\pi \left(1 + \frac{1}{(\lambda \sigma_0)}\right)} \left(\left[\frac{V_c + V_d}{V_d} \cdot p_m \cdot (\eta_0 + \eta_1 \cdot \omega_e) \right. \right. \right. \quad (\text{A.36})$$

$$\cdot (\gamma_0 + \gamma_1 \cdot \omega_e + \gamma_2 \cdot \omega_e^2) - \frac{p_e^{\frac{1}{k}} \cdot V_c}{V_d} \cdot p_m^{\frac{k-1}{k}} \cdot (\eta_0 + \eta_1 \cdot \omega_e)$$

$$\left. \left. \left. \cdot (\gamma_0 + \gamma_1 \omega_e + \gamma_2 \cdot \omega_e^2) \right] \right) - (\beta_0 + \beta_2 \cdot \omega_e^2) - (p_{exhaust} - p_m) \cdot \frac{V_d}{4\pi} \right)$$

$$\left. - T_l(t) \right]$$

Next, the partial derivative was taken with respect to manifold pressure and then with respect to engine speed. It was assumed that the torque load was zero for the time being. The results are seen in Equations (A.38) through Equation (A.44).

$$\begin{aligned} \frac{\partial f(\omega_e)}{\partial p_m} = \frac{1}{\Theta_e} & \left[\frac{H_l \cdot V_d}{\lambda \cdot \sigma_0 \cdot R \cdot \vartheta_m(t) \cdot 4\pi \left(1 + \frac{1}{(\lambda\sigma_0)}\right)} \left(\left[\frac{V_c + V_d}{V_d} \cdot (\eta_0 + \eta_1 \cdot \omega_e) \right. \right. \right. \\ & \cdot (\gamma_0 + \gamma_1 \cdot \omega_e + \gamma_2 \cdot \omega_e^2) - \frac{p_e^{\frac{1}{k}} \cdot V_c}{V_d} \cdot \frac{k-1}{k} \cdot p_m^{\frac{-1}{k}} \cdot (\eta_0 + \eta_1 \cdot \omega_e) \\ & \left. \left. \left. \cdot (\gamma_0 + \gamma_1 \omega_e + \gamma_2 \cdot \omega_e^2) \right] \right) - (0) - (-1) \cdot \frac{V_d}{4\pi} \right] \end{aligned} \quad (\text{A.37})$$

$$\begin{aligned} \frac{\partial f(\omega_e)}{\partial \omega_e} = \frac{1}{\Theta_e} & \left[\frac{H_l \cdot V_d}{\lambda \cdot \sigma_0 \cdot R \cdot \vartheta_m(t) \cdot 4\pi \left(1 + \frac{1}{(\lambda\sigma_0)}\right)} \left(\left[\frac{V_c + V_d}{V_d} \cdot p_m \right. \right. \right. \\ & \cdot \left((\eta_1) \cdot (\gamma_0 + \gamma_1 \cdot \omega_e + \gamma_2 \cdot \omega_e^2) + (\eta_0 + \eta_1 \cdot \omega_e) \cdot (\gamma_1 + 2\gamma_2 \cdot \omega_e) \right) \\ & - \frac{p_e^{\frac{1}{k}} \cdot V_c}{V_d} \cdot p_m^{\frac{k-1}{k}} \\ & \cdot \left((\eta_1) \cdot (\gamma_0 + \gamma_1 \cdot \omega_e + \gamma_2 \cdot \omega_e^2) + (\eta_0 + \eta_1 \cdot \omega_e) \right) \\ & \left. \left. \left. \cdot (\gamma_1 + 2 \cdot \gamma_2 \cdot \omega_e) \right] \right) - (2 \cdot \beta_2 \cdot \omega_e) - (0) \cdot \frac{V_d}{4\pi} \right] \end{aligned} \quad (\text{A.38})$$

$$\begin{aligned} \frac{\partial f(\omega_e)}{\partial p_m} = \frac{1}{\Theta_e} & \left[\frac{H_l \cdot V_d}{\lambda \cdot \sigma_0 \cdot R \cdot \vartheta_m(t) \cdot 4\pi \left(1 + \frac{1}{(\lambda\sigma_0)}\right)} \left(\left[\frac{V_c + V_d}{V_d} \cdot (\eta_0 + \eta_1 \cdot \omega_e) \right. \right. \right. \\ & \cdot (\gamma_0 + \gamma_1 \cdot \omega_e + \gamma_2 \cdot \omega_e^2) - \frac{p_e^{\frac{1}{k}} \cdot V_c}{V_d} \cdot \frac{k-1}{k} \cdot p_m^{\frac{-1}{k}} \cdot (\eta_0 + \eta_1 \cdot \omega_e) \\ & \left. \left. \left. \cdot (\gamma_0 + \gamma_1 \omega_e + \gamma_2 \cdot \omega_e^2) \right] \right) + \frac{V_d}{4\pi} \right] \end{aligned} \quad (\text{A.39})$$

$$\frac{\partial f(\omega_e)}{\partial \omega_e} = \frac{1}{\Theta_e} \left[\frac{H_l \cdot V_d}{\lambda \cdot \sigma_0 \cdot R \cdot \vartheta_m(t) \cdot 4\pi \left(1 + \frac{1}{(\lambda \sigma_0)}\right)} \left(\left[\frac{V_c + V_d}{V_d} \cdot p_m \right. \right. \right. \quad (\text{A.40})$$

$$\cdot ((\eta_1) \cdot (\gamma_0 + \gamma_1 \cdot \omega_e + \gamma_2 \cdot \omega_e^2)) + (\eta_0 + \eta_1 \cdot \omega_e) \cdot (\gamma_1 + 2\gamma_2 \cdot \omega_e))$$

$$\left. - \frac{p_e^{\frac{1}{k}} \cdot V_c}{V_d} \cdot p_m^{\frac{k-1}{k}} \right. \left. \cdot ((\eta_1) \cdot (\gamma_0 + \gamma_1 \cdot \omega_e + \gamma_2 \cdot \omega_e^2)) + (\eta_0 + \eta_1 \cdot \omega_e) \cdot (\gamma_1 + 2 \cdot \gamma_2 \cdot \omega_e) \right) \left. \right]$$

$$- (2 \cdot \beta_2 \cdot \omega_e) \left. \right]$$

$$\dot{\omega}_{ed} = \frac{1}{T_d} (\omega_e - \omega_{ed}) \quad (\text{A.41})$$

$$\dot{m}_{\beta d} = \frac{1}{T_d} (\dot{m}_\beta - \dot{m}_{\beta d}) \quad (\text{A.42})$$

$$\dot{m}_\beta(t) = \frac{1}{1 + \frac{1}{(\lambda \sigma_0)} R \vartheta_m(t)} \cdot p_m(t) \quad (\text{A.43})$$

$$(\gamma_0 + \gamma_1 \cdot \omega_e + \gamma_2 \cdot \omega_e^2) \cdot \left(\frac{V_c + V_d}{V_d} - \frac{V_c}{V_d} \cdot \left(\frac{p_e}{p_m(t)} \right)^{1/k} \right) \cdot V_d \cdot \frac{\omega_e(t)}{4\pi}$$

$$T_e(t) = \quad (\text{A.44})$$

$$\left(\frac{(\eta_0 + \eta_1 \cdot \omega_e) \cdot H_l \cdot \dot{m}_\beta(t - \tau_{inj \rightarrow TC}) \cdot 4\pi}{\lambda \cdot \sigma_0 \cdot \omega_e(t - \tau_{inj \rightarrow TC}) \cdot V_d} - (\beta_0 + \beta_2 \cdot \omega_e^2) \cdot \frac{4\pi}{V_d} - (p_e - p_m) \right)$$

$$\cdot \frac{V_d}{4\pi}$$

Appendix B SIGNAL GATHERING CODE

B.1 Injection and Ignition angle and timing

```

%Injection Timing
%Change the save of matrix to multiple vectors.
%Let PC Warm-up for 15 minutes
outputlog=tg.outputlog;

time=tg.timelog;
%Acquires the overall sample time of the target daq session
sampletime=tg.sampletime;

%Number of times the buffer data wrapped over
numberofdatawraps=tg.numlogwraps;
%Amount of time since task was started
TET_Time=tg.ExecTime;
%Gives a value of 'detected' a CPU overload occurs
CPUoverload=tg.CPUoverload;
%The Average Time for one execution of the model
AverageExecution=tg.AvgTET;
MATfilename=inputdlg('MAT-file File Name (.mat)', 'Input Current File
Name of Excel File');
%User Input
SteadyStateEngineSpeed=inputdlg('Engine Speed', 'Current Engine
Speed');
DynoPres=inputdlg('Load (PSI)', 'Dyno Pressure');
DynoTemp=inputdlg('Dyno Temperature (degrees C)', 'Temperature');
IMT=inputdlg('Intake Manifold Temperature', 'Intake Manifold
Temperature (Degrees C)');
EngOilTemp=inputdlg('Engine Oil Temperature', 'Engine Oil Temperature
(Degrees C)');
AFR=inputdlg('Lambda', 'Air to Fuel Ratio');
counts=outputlog(:,1);           %Crank Angle
Spark=outputlog(:,2);           %Spark Signal
Injection=outputlog(:,3);       %Injection Signal
throttle=outputlog(:,4);        %Intake Manifold Pressure
Range=size(time);
MinTET=tg.MinTET;
MaxTET=tg.MaxTET;
%matrix of time and logged signals
A=[time counts Spark Injection throttle ];
%Matrix of target pc status
%Create the cell array containing the column headers

```

```

statusHeader1={'Sample Time (sec)', 'Number of Circular Buffer
Wraps', 'MinTET', ...
    'Ideal Engine Speed (rpms)', 'Dyno Temperature (degrees C)', 'Air
to Fuel Ratio'};
targetstatus1=[sampletime numberofdatawraps MinTET
SteadyStateEngineSpeed DynoTemp AFR];
statusHeader2={'Average Execution Time (sec)', 'Execution
Time', 'MaxTET', 'Load (PSI)', ...
    'Intake Manifold Temperature (degrees C)', 'Engine Oil Temperature
(Degrees C)'};
targetstatus2=[AverageExecution TET_Time MaxTET DynoPres IMT
EngOilTemp];

columnHeader={'Time (sec) ', 'Counts', 'Spark
Signal', 'Injection', 'throttle'};
%Changes the numerical array into a cell array
numericalData= num2cell(A);
%Combines both status data and numerical data with headings
Combinedata=[columnHeader; numericalData];
statusofdaq=[statusHeader1;targetstatus1;statusHeader2;targetstatus2]
;
%When compining cells number of colums must be the same
% http://www.mathworks.com/help/techdoc/import\_export/braidzi-1.html
% http://www.mathworks.com/help/techdoc/import\_export/braidzi-1.html#br\_4ten
% -----
% -----
% -----
savefile=char(MATfilename);%-----
% -----
% -----
% -----

save(savefile, 'Combinedata', 'time', 'statusofdaq', 'counts',
'Spark', 'Injection', 'throttle')

```

B.2 Mass Air Flow

```

%Throttle Dynamic and Volumetric Efficiency Measurement
%Let PC Warm-up for 15 minutes
outputlog=tg.outputlog;

time=tg.timelog;
%Acquires the sample time of the target
sampletime=tg.sampletime;
MinTET=tg.MinTET;
MaxTET=tg.MaxTET;
% not execute
%Number of times the buffer data wrapped over
numberofdatawraps=tg.numlogwraps;
%Amount of time since task was started
TET_Time=tg.ExecTime;
%Gives a value of 'detected' a CPU overload occurs
CPUoverload=tg.CPUoverload;
%The Average Time for one execution of the model
AverageExecution=tg.AvgTET;
MATfilename=inputdlg('MAT-file File Name (.mat)', 'Input Current File
Name of Excel File');
%   a={'ab','cde','fghi'};
%   as1=char(Excelfilename) % note: a char mat
%   as2=cat(2,Excelfilename{:}) % note: no spaces between cells
%   as3=sprintf('%s|',Excelfilename{:}); % the most versatile
%   as3(end)=''
SteadyStateEngineSpeed=inputdlg('Engine Speed', 'Current Engine
Speed');
DynoPres=inputdlg('Load (PSI)', 'Dyno Pressure');
DynoTemp=inputdlg('Dyno Temperature (degrees C)', 'Temperature');
IMT=inputdlg('Intake Manifold Temperature', 'Intake Manifold
Temperature (Degrees C)');
EngOilTemp=inputdlg('Engine Oil Temperature', 'Engine Oil Temperature
(Degrees C)');
AFR=inputdlg('Lambda', 'Air to Fuel Ratio');
MAF=outputlog(:,2); %Volume Air Flow L/m
Pressure=outputlog(:,1); %Intake Manifold Pressure mbar
Throttle=outputlog(:,3); %Throttle Angel
ENCounts=outputlog(:,4); %Encoder output count
Datamatrix=[time ENCounts Pressure MAF Throttle]; %matrix of

```

```

time and logged signals
%Create the cell array containing the column headers

%Create the cell array containing the column headers
statusHeader1={'Sample Time (sec)', 'Number of Circular
Buffer Wraps', 'MinTET', ...
    'Ideal Engine Speed (rpms)', 'Dyno Temperature (degrees
C)', 'Air to Fuel Ratio'};
targetstatus1=[sampletime numberofdatawraps MinTET
SteadyStateEngineSpeed DynoTemp AFR];
statusHeader2={'Average Execution Time (sec)', 'Execution
Time', 'MaxTET', 'Load (PSI)', ...
    'Intake Manifold Temperature (degrees C)', 'Engine Oil
Temperature (Degrees C)'};
targetstatus2=[AverageExecution TET_Time MaxTET DynoPres
IMT EngOilTemp];
columnHeader={'Time (sec) ', 'Encoder Counts', 'Intake
Manifold Pressure', 'Volume Air Flow'...
    'Throttle Angel'};
%Changes the numerical array into a cell array
%Combines both status data and numerical data with headings
%Changes the numerical array into a cell array
numericalData= num2cell(Datamatrix);
%combube the two cell arrays into one
throttledynamic= [columnHeader; numericalData];           %Puts
all data and heading in Matrix
%Shows status of data collection
statusofdaq=[statusHeader1;targetstatus1;statusHeader2;targ
etstatus2];
savefile=char(MATfilename);%-----
-----
% -----
-----
% -----
-----

save(savefile, 'throttledynamic', 'statusofdaq',
'Pressure', 'MAF', 'Throttle', 'ENCOUNTS');

```

B.3 Processing for throttle dynamic and volumetric efficiency coefficients

```

%Analysis of the first 180 degrees. Averaging over the first 180
degrees.
%% Loads each file to execute
% function intakeplotdynamic2()
clear
maActV=zeros(18,1);%the row value is the total number of data points
ThrActV=zeros(18,1);
PaActV=zeros(18,1);
weAct=zeros(18,1);
inTempAct=zeros(18,1);
savedir='C:\Documents and Settings\Cory\Desktop\Image';
Index=1;
rootname='thr_04212011_gas';%Root folder location of .mat files
fueltype='gas';
filename='thr_04212011_';

for I=0:5:20                                %Loads the different files 1200
%     directory='';
testpoint='1200';
ffilename=['_',int2str(I),'.mat'];
filenamesave=[filename, fueltype,'_', testpoint, ffilename];
file=[rootname filesep filenamesave]
[IMPmean0_180 MAFmean0_180 THRmean0_180 intaketemp
enginespeed]=searchandfifotest5(file,testpoint);
weAct(Index,1)=mean(enginespeed);
maActV(Index,1)=mean(MAFmean0_180);
ThrActV(Index,1)=mean(THRmean0_180);
PaActV(Index,1)=mean(IMPmean0_180);
inTempAct(Index,1)=intaketemp;
Index=Index+1;

end

for I=5:5:20%1500
testpoint='1500';
ffilename=['_',int2str(I),'.mat'];
filenamesave=[filename, fueltype,'_', testpoint, ffilename];
file=[rootname filesep filenamesave]
[IMPmean0_180 MAFmean0_180 THRmean0_180 intaketemp
enginespeed]=searchandfifotest5(file,testpoint);
weAct(Index,1)=mean(enginespeed);
maActV(Index,1)=mean(MAFmean0_180);
ThrActV(Index,1)=mean(THRmean0_180);
PaActV(Index,1)=mean(IMPmean0_180);
inTempAct(Index,1)=intaketemp;
Index=Index+1;

end

```

```

for I=5:5:20%1800
    testpoint='1800';
    filename=['_',int2str(I),'.mat'];
    filenamesave=[filename, fueltype,'_', testpoint, filename];
    file=[rootname filesep filenamesave]
    [IMPmean0_180 MAFmean0_180 THRmean0_180 intaketemp
enginespeed]=searchandfifotest5(file,testpoint);
    weAct(Index,1)=mean(enginespeed);
    maActV(Index,1)=mean(MAFmean0_180);
        ThrActV(Index,1)=mean(THRmean0_180);
        PaActV(Index,1)=mean(IMPmean0_180);
            inTempAct(Index,1)=intaketemp;

    Index=Index+1;
end

for I=10:5:20%2100
    testpoint='2100';
    filename=['_',int2str(I),'.mat'];
    filenamesave=[filename, fueltype,'_', testpoint, filename];
    file=[rootname filesep filenamesave]
    [IMPmean0_180 MAFmean0_180 THRmean0_180 intaketemp
enginespeed]=searchandfifotest5(file,testpoint);
    weAct(Index,1)=mean(enginespeed);
    maActV(Index,1)=mean(MAFmean0_180);
        ThrActV(Index,1)=mean(THRmean0_180);
        PaActV(Index,1)=mean(IMPmean0_180);
            inTempAct(Index,1)=intaketemp;
    Index=Index+1;
end

for I=15:5:20%2400
    testpoint='2400';
    filename=['_',int2str(I),'.mat'];
    filenamesave=[filename, fueltype,'_', testpoint, filename];
    file=[rootname filesep filenamesave]
    [IMPmean0_180 MAFmean0_180 THRmean0_180 intaketemp
enginespeed]=searchandfifotest5(file,testpoint);
    weAct(Index,1)=mean(enginespeed);
    maActV(Index,1)=mean(MAFmean0_180);
        ThrActV(Index,1)=mean(THRmean0_180);
        PaActV(Index,1)=mean(IMPmean0_180);
            inTempAct(Index,1)=intaketemp;
    Index=Index+1;
end

```

```

%% Determines the start of crank based in engine speed
function [IMPmean0_180 MAFmean0_180 THRmean0_180 intaketemp
enginespeed]=searchandfifotest5(file,testpoint,~, ~, ~)

% file ='thr_04212011_gas\thr_04212011_gas_2100_20.mat';

%Loads the .mat file w/ vectors ENCounts MAF Pressure Throttle
vars={'ENCounts', 'Pressure', 'Throttle', 'time',
'MAF','statusofdaq'};
load(file, vars{:});
%X is the encoder count and Y is the value to be interpolated
v=1;
X=zeros(size(ENCounts(:)));
ytime=zeros(size(ENCounts(:)));
yIMP=zeros(size(ENCounts(:)));
yMAF=zeros(size(ENCounts(:)));
yThr=zeros(size(ENCounts(:)));
ENCounts=abs(ENCounts);

for Index=1:length(ENCounts)
    if Index == length(ENCounts)      %To Aquire the last value
in the vector
        v=v+1;
        X(v,1)=ENCounts(Index,1);
        ytime(v,1)=time(Index,1);
        yIMP(v,1)=Pressure(Index,1);
        yMAF(v,1)=MAF(Index,1);
        yThr(v,1)=Throttle(Index,1);
    end
    %Current and Next evaluated counts are the same value. Nothing
    %changes new value is placed in to vector X.
    if Index<=length(ENCounts)-1
        if ENCounts(Index,1) == ENCounts(Index+1,1)
            X(v,1)=ENCounts(Index,1);
            ytime(v,1)=time(Index,1);
            yIMP(v,1)=Pressure(Index,1);
            yMAF(v,1)=MAF(Index,1);
            yThr(v,1)=Throttle(Index,1);
            v=v+1;
        end
        %The next count value has increased by one. Count based to
X vector
        if ENCounts(Index+1,1) == ENCounts(Index,1)+1
            X(v,1)=ENCounts(Index,1);
            ytime(v,1)=time(Index,1);

```

```

        yIMP(v,1)=Pressure(Index,1);
        yMAF(v,1)=MAF(Index,1);
        yThr(v,1)=Throttle(Index,1);
        v=v+1;
    end
    %If the next value is not the same and a difference on one a
value
    %needs to be added in the next slot. Could Assume the next
value
    %has a difference of only 2 and the difference of one value
needs
    %to be added.
    if ENCounts(Index,1) ~= ENCounts(Index+1,1)
        if ENCounts(Index+1,1) ~= ENCounts(Index,1)+1
            X(v,1)=ENCounts(Index,1);
            ytime(v,1)=time(Index,1);
            yIMP(v,1)=Pressure(Index,1);
            yThr(v,1)=Throttle(Index,1);
            yMAF(v,1)=MAF(Index,1);

            v=v+1;

            ytime(v,1) =(0.5)*(time(Index,1)-
time(Index+1,1))+ (time(Index+1,1));
            yIMP(v,1)=(0.5)*(Pressure(Index,1)-
Pressure(Index+1,1))+ (Pressure(Index+1,1));
            yMAF(v,1)=(0.5)*(MAF(Index,1)-
MAF(Index+1,1))+ (MAF(Index+1,1));
            yThr(v,1)=(0.5)*(Throttle(Index,1)-
Throttle(Index+1,1))+ (Throttle(Index+1,1));

            if ENCounts(Index,1)==499 && ENCounts(Index+1,1)~=0
                X(v,1)=0;
                X(v,2)=1;
                v=v+1;
            end
            if ENCounts(Index,1)+1 ~= 500
                X(v,1)=ENCounts(Index,1)+1;
                X(v,2)=1;
                v=v+1;
            end
        end
    end
end
end
end
junk0=find(ytime(:,1)== 0)
junkNaN = find(isnan(ytime(:,1)))==1)

```

```

%% Find the
clear ENCounts time Pressure MAF
ENCounts=X(:,1);
time=ytime(:,1);
Pressure=yIMP;
MAF=yMAF;
Throttle=yThr;
clear X ytime yIMP yMAF

ind0=find(ENCounts == 0);           %Position of zero values
zerotime=time(ind0);
zerocount=[zerotime,ind0,zeros(length(ind0),1)];

ind499=find(ENCounts == 499);       %Position of 499 aka end of
count
endtime=time(ind499);
endcount=[endtime,ind499,ones(length(ind499),1)*499];
sorted=sortrows([zerocount;endcount],1);
if sorted(1,2)>sorted(2,2)
    sorted(1,:)=[];
end
%% Determining engine stroke based on encoder position and time
stamp
    %Preallocation
    cycle=zeros(10000,10); %Number of rows arbitrarily selected
    K=0;
    T=0;
    %Determine the stroke four strokes.
% while loop continues until slower cycle ie (1) is smaller than
cycle(2)
%Where cycle(1) is considered the the 360 degrees of intake and
compression
%stroke and cycle(2) is the expansion to exhaust stroke.
if K<= length(sorted)%loop continues until the speed in cycle 1 is
greater than the speed in cycle 2
K=K+1; %Increments the K value.
T=T+1;
while (cycle(T,1) >= cycle(T,2)) && (K<length(sorted))%Stops the
loop when cycle(1) is greater than cycle(2)
    if cycle(T,1) == 0
        if sorted(K,3) == 0 && cycle(T,3) == 0
            cycle(T,3) = sorted(K,1) ;           %The first zero
value
            cycle(T,5) = sorted(K,2) ;           %The index of the
first value
            K=K+1;
        end
    end
end
    %Logic to acquire the end value for the cycle

```

```

        If cycle(T,1)>cycle(T,2) && cycle(T,2) > 0
            T=T+1;
        end
    end
end
end
clear T K
%Clears not full cycles and remaining zeros.

G= cycle(:,1)== 0;
cycle(G,:)=[];
G= cycle(:,2)== 0;
cycle(G,:)=[];
cycle2=cycle;
% Deletes rows of incorrect cycles
% delrows=
find(cycle(:,1)>((1/str2double(testpoint))*60)+0.005)
% cycle2(delrows,:)=[];

delrows= cycle(:,1)>((1/str2double(testpoint))*60)+0.005;
cycle2((delrows==1),:)=[];
%% Extract the first 180 degrees of crank angle (complete)
MAFlist=zeros(length(cycle2),1);
IMPlist=zeros(length(cycle2),1);
THRlist=zeros(length(cycle2),1);

for v=1:size(cycle2,1)
    %Gives the index ie row value of count 250
    search1=find((ENCOUNTS(cycle2(v,5):cycle2(v,6))== 250));
    search2=find((ENCOUNTS(cycle2(v,5):cycle2(v,6))== 251));
    searchmin=min([search1;search2])+cycle2(v,5)-1;
    MAFlist(v,1)=nanmean(MAF(cycle2(v,5):searchmin));
    IMPlist(v,1)=nanmean(Pressure(cycle2(v,5):searchmin));
    THRlist(v,1)=nanmean(Throttle(cycle2(v,5):searchmin));
end

IMPmean0_180=(IMPlist);
MAFmean0_180=(MAFlist);
THRmean0_180=(THRlist);
enginespeed=2.*((1./(cycle2(:,1)+cycle2(:,2))).*60);
intaketemp=str2double(statusofdaq(4,5))+273.19;

```

B.4 Willan's Line

The Willan's Line is a method of approximating indicated power for either a multi or single cylinder engine. The method is based on that at light engine load a little fuel is pumped into the air stream entering the engine cylinder. Therefore there is a lot of air available for combustion resulting in almost constant combustion efficiency. Greene and Lucas (1969) states "this method is not suitable for use with petrol engines." (Greene & Lucas, 1969) With the constant speed approximation made by Guzzella and Onder (2004). This approximation is used in

Appendix C EXPERIMENTAL DATA

Average Engine Speed (rpm)	Intake Mass Air Flow (kg/s)	Intake Manifold Pressure (Pa)
1303	2.39E-04	584.69
1259	3.11E-04	616.19
1187	3.21E-04	712.56
1240	3.57E-04	727.31
1226	3.88E-04	806.05
1555	3.41E-04	633.08
1579	3.81E-04	705.69
1470	3.83E-04	737.52
1513	4.24E-04	789.89
1866	3.74E-04	663.75
1862	4.11E-04	703.65
1869	4.36E-04	748.78
1823	4.58E-04	785.92
2154	4.39E-04	676.53
2155	4.63E-04	750.88
2194	5.15E-04	771.90
2443	4.95E-04	763.08
2454	5.27E-04	769.76

Table C.1: E85- Mass Air Flow and Intake Manifold Pressure

Average Engine Speed (rpm)	Intake Mass Air Flow (kg/s)	Intake Manifold Pressure (Pa)
1236	2.70E-04	1333.76
1278	4.76E-04	1378.07
1268	4.14E-04	1380.50
1276	4.67E-04	1394.24
1285	5.22E-04	1398.07
1534	4.90E-04	1379.79
1563	4.39E-04	1384.29
1541	4.69E-04	1398.54
1500	5.08E-04	1398.47
1848	5.26E-04	1375.69
1872	4.88E-04	1396.18
1846	5.02E-04	1344.57
1834	5.77E-04	1406.59
2172	5.19E-04	1395.18
2172	5.44E-04	1330.65
2169	6.28E-04	1390.97
2372	5.70E-04	1346.79
2465	6.85E-04	1389.41

Table C.2: Gasoline-Mass Air Flow and Intake Manifold Pressure

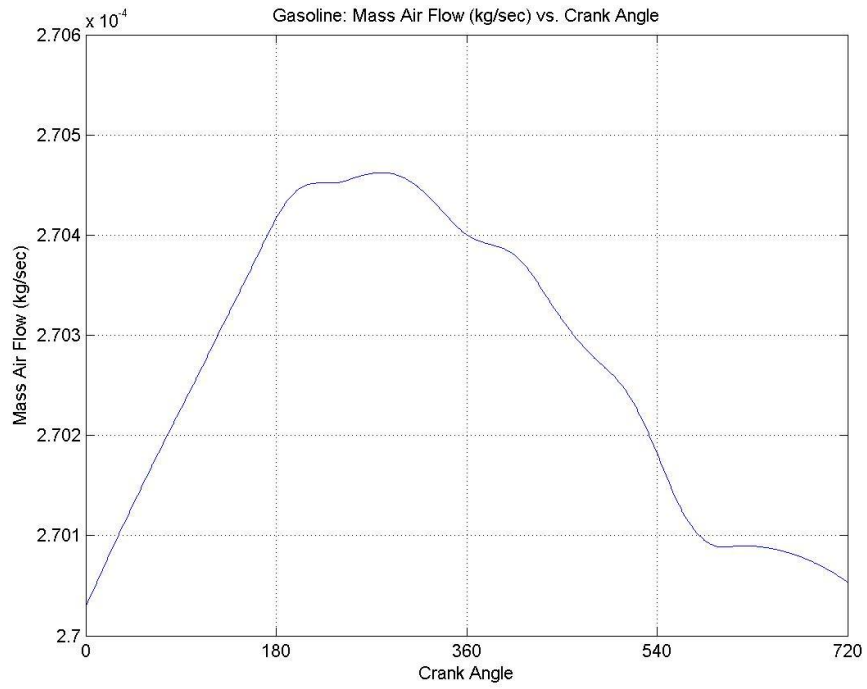

Figure 0.1: Mass Air Flow and 1200 rpm and 0% Throttle

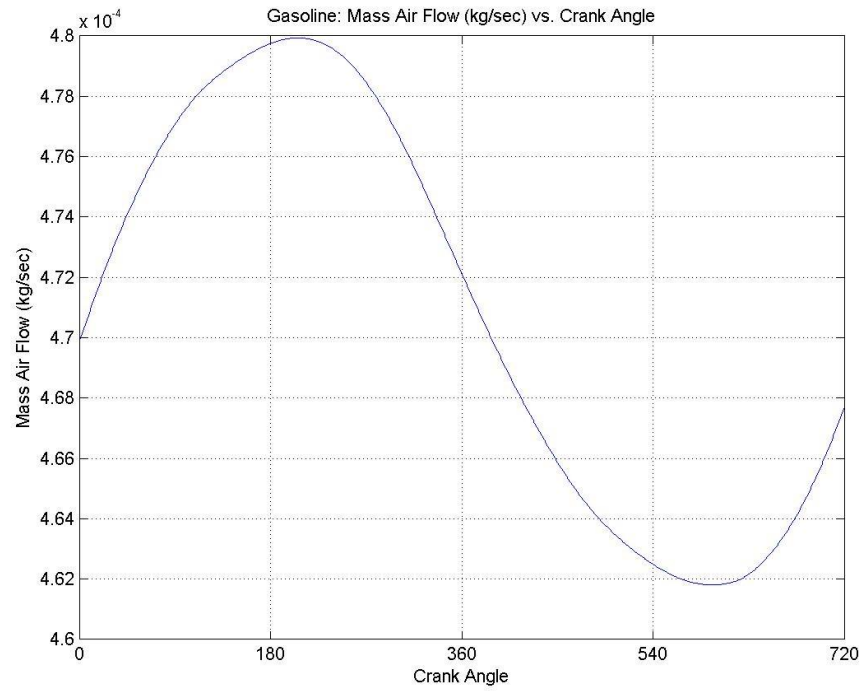

Figure 0.2: Mass Air Flow and 1200 rpm and 5% Throttle

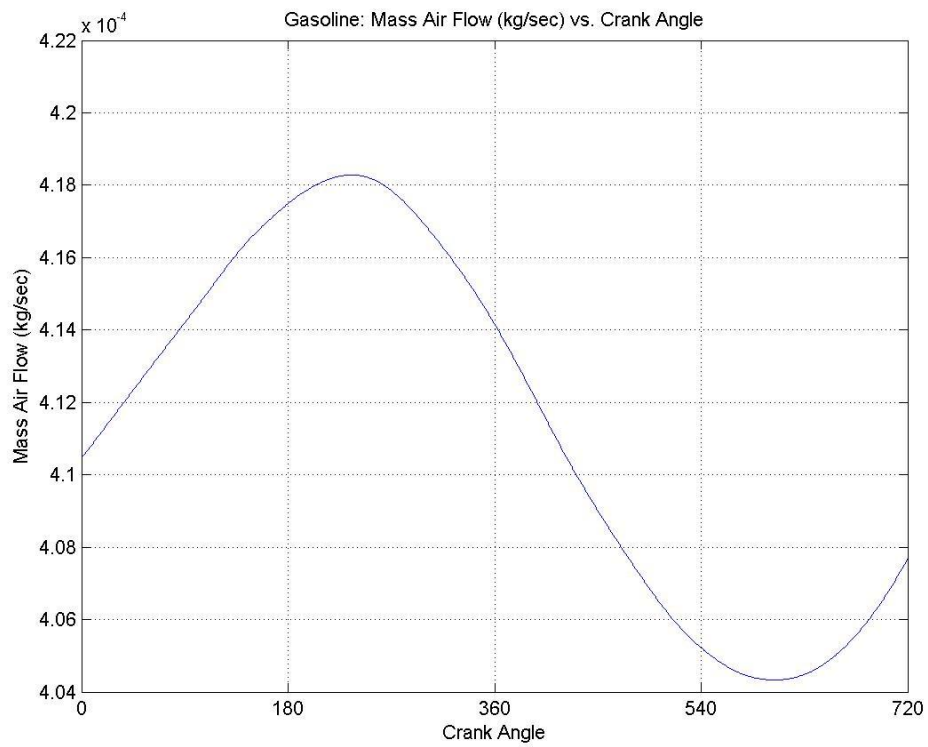

Figure 0.3: Mass Air Flow and 1200 rpm and 10% Throttle

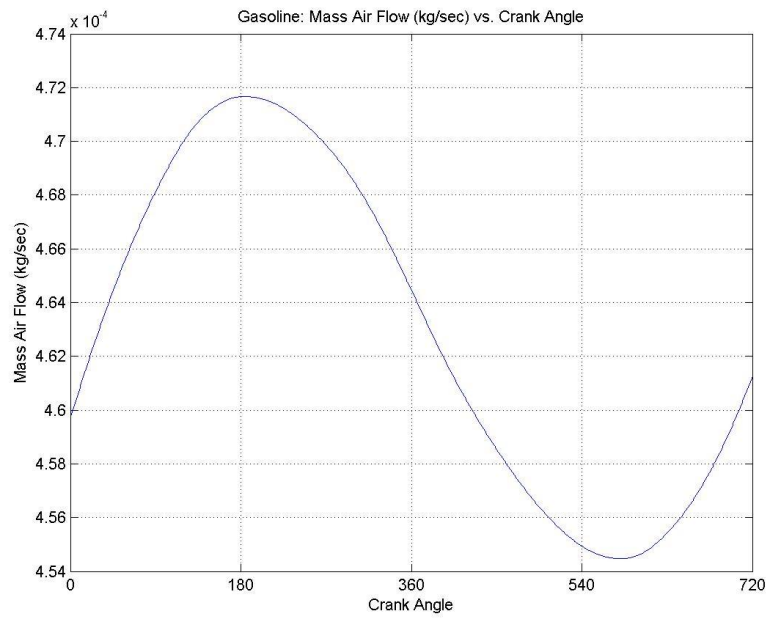

Figure 0.4: Mass Air Flow and 1200 rpm and 15% Throttle

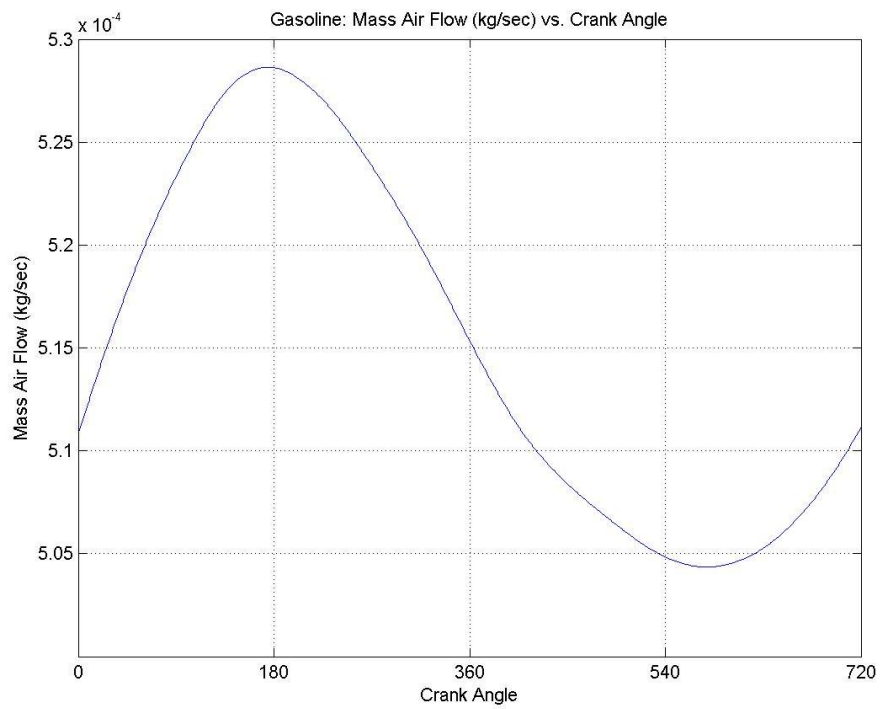

Figure 0.5: Mass Air Flow and 1200 rpm and 20% Throttle

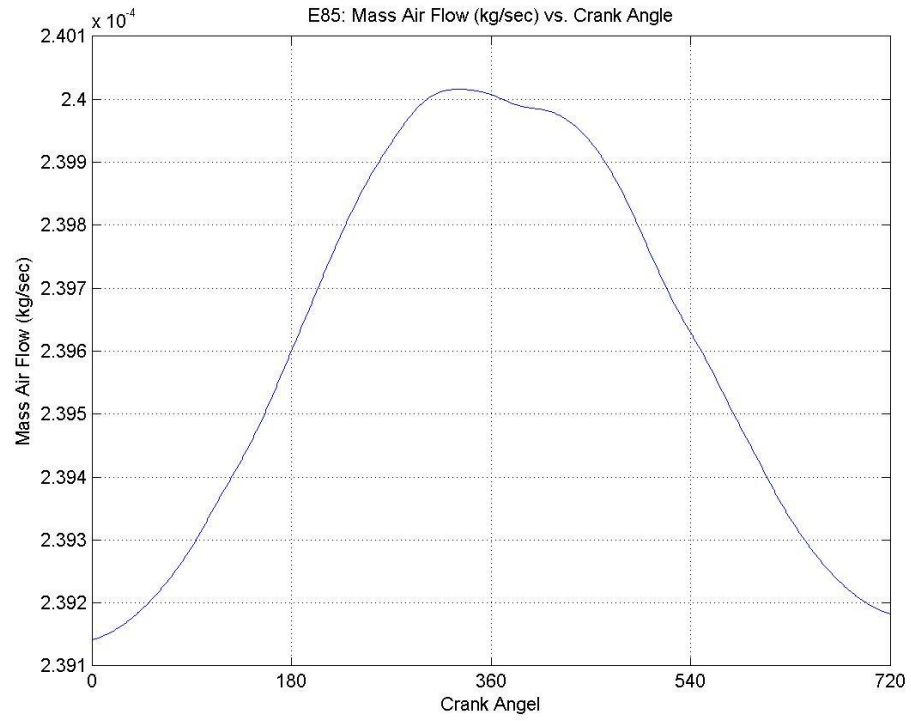

Figure 0.6: E85 Mass Air Flow and 1200 rpm and 0% Throttle

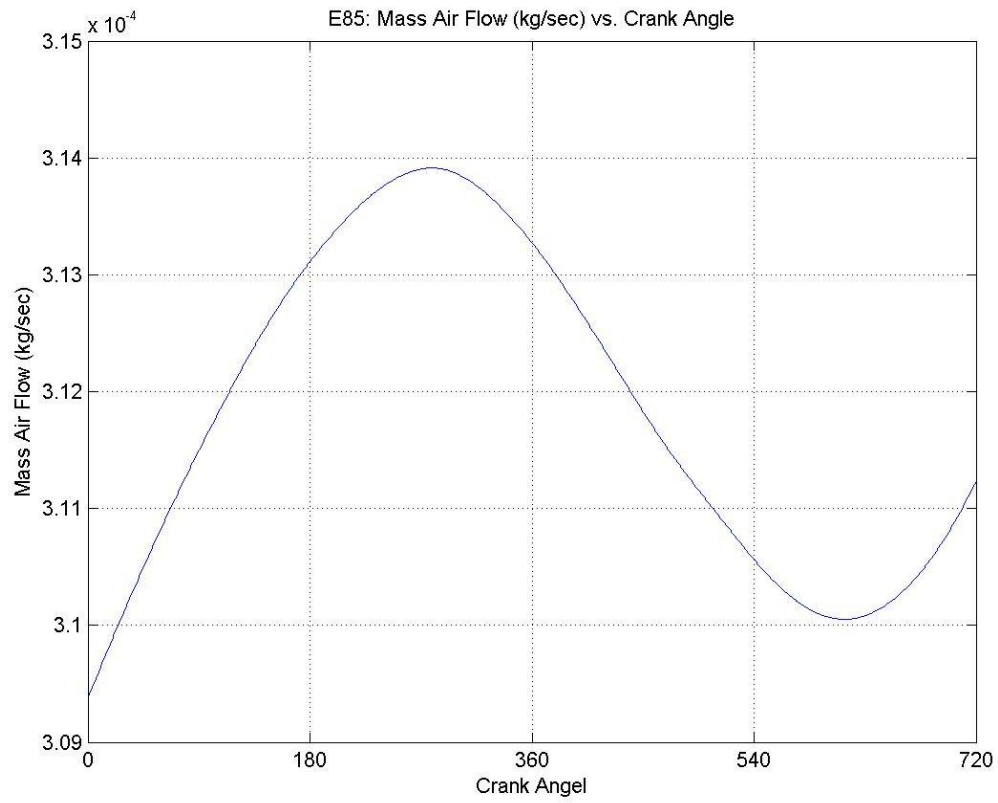

Figure 0.7: E85 Mass Air Flow and 1200 rpm and 0% Throttle

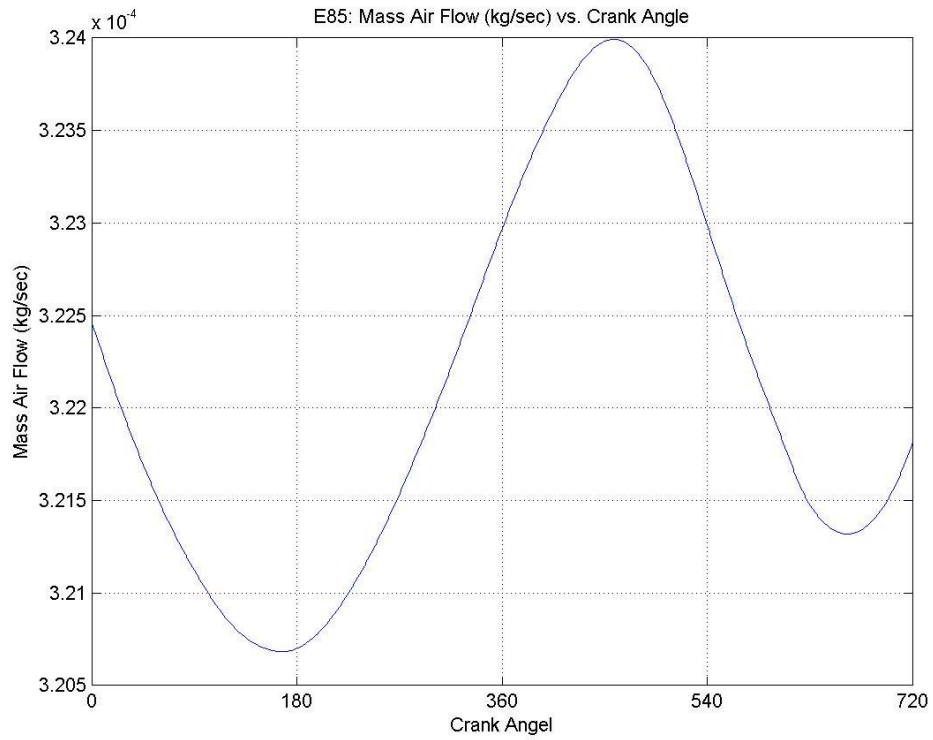

Figure 0.8: E85 Mass Air Flow and 1200 rpm and 10% Throttle

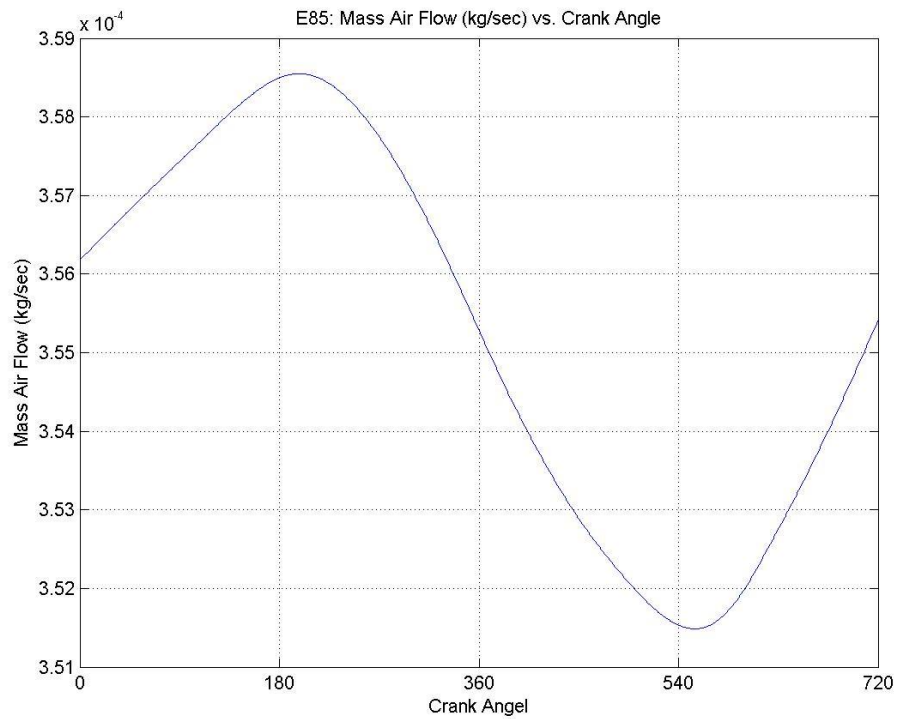

Figure 0.9: E85 Mass Air Flow and 1200 rpm and 15% Throttle

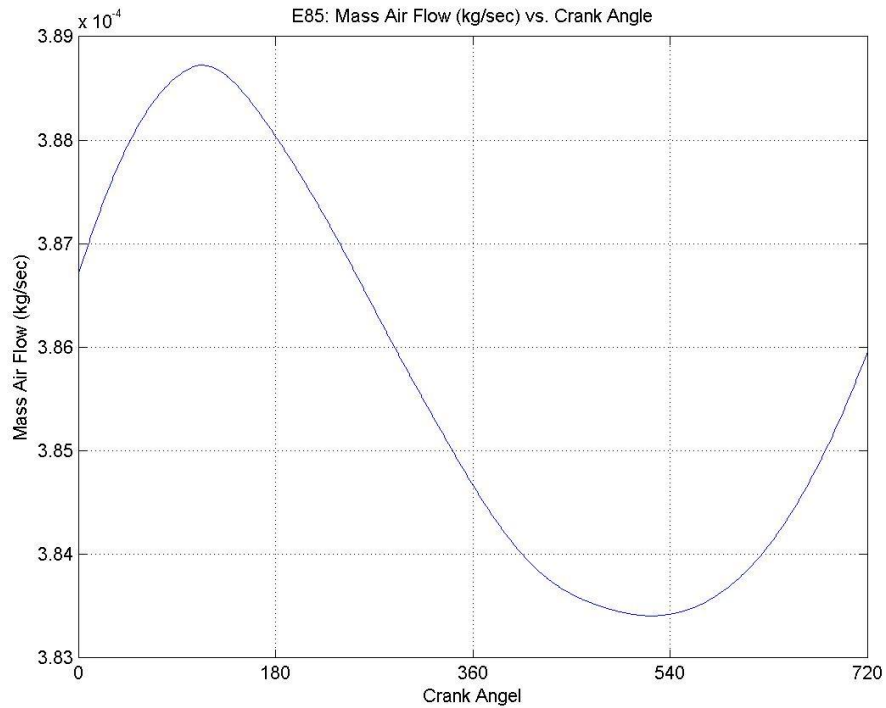

Figure 0.10: E85 Mass Air Flow and 1200 rpm and 20% Throttle

Injection and Spark

Throttle Angle	1200 (rpm)	1500 (rpm)	1800 (rpm)	2100 (rpm)	2400 (rpm)
20	383	392	405	413	422
15	381	387	397	403	408
10	377	382	389	395	
5	376	383	390		
0	374				

Table C.3: Gasoline: Minimum Injection Angle

Throttle Angle	1200 (rpm)	1500 (rpm)	1800 (rpm)	2100 (rpm)	2400 (rpm)
20	390	405	606	431	441
15	389	396	408	418	425
10	384	392	401	408	
5	382	392	401		
0	380				

Table C.4: Gasoline: Maximum Injection Angle

Throttle Angle	1200 (rpm)	1500 (rpm)	1800 (rpm)	2100 (rpm)	2400 (rpm)
20	699	700	702	702	703
15	700	700	701	702	703
10	699	701	701	702	
5	699	702	701		
0	699				

Table C.5: Gasoline: Average Ignition Angle

Throttle Angle	1200 (rpm)	1500 (rpm)	1800 (rpm)	2100 (rpm)	2400 (rpm)
20	703	705	707	708	710
15	703	705	707	718	710
10	703	705	707	708	
5	703	705	707		
0	703				

Table C.6: Gasoline: Maximum Ignition Angle

Throttle Angle	1200 (rpm)	1500 (rpm)	1800 (rpm)	2100 (rpm)	2400 (rpm)
20	39	51	6	73	83
15	35	42	52	60	68
10	29	36	43	51	
5	26	35	43		
0	23				

Table C.7: Gasoline: Maximum Injection Angle

Throttle Angle	1200 (rpm)	1500 (rpm)	1800 (rpm)	2100 (rpm)	2400 (rpm)
20	386	398	472	420	431
15	384	392	406	411	416
10	381	387	395	401	
5	379	388	396		
0	377				

Table C.8: Gasoline: Average Injection Angle

Throttle Angle	1200 (rpm)	1500 (rpm)	1800 (rpm)	2100 (rpm)	2400 (rpm)
20	31	38	51	56	64
15	27	32	40	46	52
10	21	26	31	36	
5	19	27	31		
0	16				

Table C.9: Gasoline: Minimum Injection Angle

Throttle Angle	1200 (rpm)	1500 (rpm)	1800 (rpm)	2100 (rpm)	2400 (rpm)
20	695	695	696	695	695
15	695	695	695	696	695
10	695	695	695	695	
5	695	696	695		
0	695				

Table C.10: Gasoline: Minimum Ignition Angle

Throttle Angle	1200 (rpm)	1500 (rpm)	1800 (rpm)	2100 (rpm)	2400 (rpm)
20	342	343	346	348	350
15	342	343	346	348	349
10	343	344	346	348	
5	343	345	346		
0	342				

Table C.11: Gasoline: Maximum Ignition Angle

Throttle Angle	1200 (rpm)	1500 (rpm)	1800 (rpm)	2100 (rpm)	2400 (rpm)
20	335	335	335	335	335
15	335	335	336	336	336
10	336	335	335	336	
5	336	335	336		
0	335				

Table C.12: Gasoline: Minimum Ignition Angle

Throttle Angle	1200 (rpm)	1500 (rpm)	1800 (rpm)	2100 (rpm)	2400 (rpm)
20	0.0040	0.0040	0.0010	0.0040	0.0040
15	0.0030	0.0030	0.0030	0.0030	0.0030
10	0.0030	0.0030	0.0030	0.0030	
5	0.0020	0.0030	0.0030		
0	0.0020				

Table C.13: Gasoline: Minimum Low Injection Duration

Throttle Angle	1200 (rpm)	1500 (rpm)	1800 (rpm)	2100 (rpm)	2400 (rpm)
20	0.0050	0.0050	0.0050	0.0050	0.0050
15	0.0040	0.0040	0.0040	0.0040	0.0040
10	0.0040	0.0040	0.0040	0.0040	
5	0.0030	0.0040	0.0040		
0	0.0030				

Table C.14: Gasoline: Maximum Low Injection Duration

Throttle Angle	1200 (rpm)	1500 (rpm)	1800 (rpm)	2100 (rpm)	2400 (rpm)
20	0.0460	0.0370	0.0290	0.0240	0.0210
15	0.0470	0.0390	0.0300	0.0250	0.0220
10	0.0480	0.0380	0.0310	0.0260	
5	0.0490	0.0370	0.0310		
0	0.0520				

Table C.15: Gasoline: Maximum High Injection Duration

Throttle Angle	1200 (rpm)	1500 (rpm)	1800 (rpm)	2100 (rpm)	2400 (rpm)
20	0.0390	0.0320	0.0100	0.0220	0.0190
15	0.0400	0.0350	0.0270	0.0230	0.0200
10	0.0420	0.0350	0.0280	0.0240	
5	0.0430	0.0340	0.0280		
0	0.0470				

Table C.16: Gasoline: Minimum High Injection Duration

Throttle Angle	1200 (rpm)	1500 (rpm)	1800 (rpm)	2100 (rpm)	2400 (rpm)
20	336	336	336	336	336
15	336	336	336	336	336
10	336	336	336	336	
5	336	336	336		
0	336				

Table C.17: E85: Minimum Ignition Angle

Throttle Angle	1200 (rpm)	1500 (rpm)	1800 (rpm)	2100 (rpm)	2400 (rpm)
20	399	411	416	426	429
15	399	408	413	419	426
10	391	403	407	414	
5	394	395	404		
0	384				

Table C.18: E85: Maximum Injection Angle

Throttle Angle	1200 (rpm)	1500 (rpm)	1800 (rpm)	2100 (rpm)	2400 (rpm)
20	392	400	405	412	415
15	392	398	401	405	410
10	384	392	395	400	
5	382	386	393		
0	377				

Table C.19: E85: Minimum Injection Angle

Throttle Angle	1200 (rpm)	1500 (rpm)	1800 (rpm)	2100 (rpm)	2400 (rpm)
20	696	696	695	695	696
15	695	695	696	696	696
10	696	695	695	696	
5	695	695	696		
0	696				

Table C.20: E85: Minimum Ignition Angle

Throttle Angle	1200 (rpm)	1500 (rpm)	1800 (rpm)	2100 (rpm)	2400 (rpm)
20	342	344	346	348	350
15	343	345	346	348	350
10	342	344	346	348	
5	343	344	346		
0	343				

Table C.21: E85: Maximum Ignition Angle

Throttle Angle	1200 (rpm)	1500 (rpm)	1800 (rpm)	2100 (rpm)	2400 (rpm)
20	396	405	410	419	422
15	395	402	407	412	418
10	388	398	401	408	
5	388	391	399		
0	381				

Table C.22: E85: Average Injection Angle

Throttle Angle	1200 (rpm)	1500 (rpm)	1800 (rpm)	2100 (rpm)	2400 (rpm)
20	49	58	61	70	71
15	47	53	58	63	68
10	37	48	51	56	
5	40	40	45		
0	27				

Table C.23: E85: Maximum Injection Angle

Throttle Angle	1200 (rpm)	1500 (rpm)	1800 (rpm)	2100 (rpm)	2400 (rpm)
20	42	46	49	56	56
15	38	43	45	48	53
10	30	37	37	43	
5	26	29	35		
0	19				

Table C.24: E85: Minimum Injection Angle

Throttle Angle	1200 (rpm)	1500 (rpm)	1800 (rpm)	2100 (rpm)	2400 (rpm)
20	701	701	701	703	703
15	700	700	701	702	703
10	699	700	701	702	
5	699	701	701		
0	699				

Table C.25: E85: Average Ignition Angle

Throttle Angle	1200 (rpm)	1500 (rpm)	1800 (rpm)	2100 (rpm)	2400 (rpm)
20	703	705	707	708	711
15	703	706	707	708	710
10	703	705	706	709	
5	703	705	707		
0	703				

Table C.26: E85: Maximum Ignition Angle

Throttle Angle	1200 (rpm)	1500 (rpm)	1800 (rpm)	2100 (rpm)	2400 (rpm)
20	336	336	336	336	336
15	336	336	336	336	336
10	336	336	336	336	
5	336	336	336		
0	336				

Table C.27: E85: Minimum Ignition Angle

Throttle Angle	1200 (rpm)	1500 (rpm)	1800 (rpm)	2100 (rpm)	2400 (rpm)
20	0.0400	0.0320	0.0270	0.0230	0.0200
15	0.0390	0.0320	0.0270	0.0230	0.0200
10	0.0430	0.0330	0.0280	0.0230	
5	0.0400	0.0340	0.0280		
0	0.0450				

Table C.28: E85: High Minimum: Injection Duration

Throttle Angle	1200 (rpm)	1500 (rpm)	1800 (rpm)	2100 (rpm)	2400 (rpm)
20	0.0470	0.0370	0.0290	0.0240	0.0220
15	0.0440	0.0350	0.0300	0.0250	0.0220
10	0.0480	0.0380	0.0310	0.0250	
5	0.0470	0.0370	0.0300		
0	0.0500				

Table C.29: E85: High Maximum: Injection Duration

Throttle Angle	1200 (rpm)	1500 (rpm)	1800 (rpm)	2100 (rpm)	2400 (rpm)
20	0.0050	0.0050	0.0040	0.0040	0.0040
15	0.0050	0.0040	0.0040	0.0030	0.0030
10	0.0040	0.0040	0.0030	0.0030	
5	0.0030	0.0030	0.0030		
0	0.0030				

Table C.30: E85: Low Minimum: Injection Duration

Throttle Angle	1200 (rpm)	1500 (rpm)	1800 (rpm)	2100 (rpm)	2400 (rpm)
20	0.0060	0.0060	0.0050	0.0050	0.0050
15	0.0060	0.0050	0.0050	0.0040	0.0040
10	0.0050	0.0050	0.0040	0.0040	
5	0.0050	0.0040	0.0040		
0	0.0040				

Table C.31: E85: Low Maximum: Injection Duration