

---

Masters Theses

Student Theses and Dissertations

---

Fall 2012

## Reliability evaluation of distribution systems containing renewable distributed generations

Abdulaziz Abdullh Alkuhayli

Follow this and additional works at: [https://scholarsmine.mst.edu/masters\\_theses](https://scholarsmine.mst.edu/masters_theses)



Part of the [Electrical and Computer Engineering Commons](#)

Department:

---

### Recommended Citation

Abdullh Alkuhayli, Abdulaziz, "Reliability evaluation of distribution systems containing renewable distributed generations" (2012). *Masters Theses*. 6945.

[https://scholarsmine.mst.edu/masters\\_theses/6945](https://scholarsmine.mst.edu/masters_theses/6945)

This thesis is brought to you by Scholars' Mine, a service of the Missouri S&T Library and Learning Resources. This work is protected by U. S. Copyright Law. Unauthorized use including reproduction for redistribution requires the permission of the copyright holder. For more information, please contact [scholarsmine@mst.edu](mailto:scholarsmine@mst.edu).



RELIABILITY EVALUATION OF DISTRIBUTION SYSTEMS CONTAINING  
RENEWABLE DISTRIBUTED GENERATIONS

by

ABDULAZIZ ABDDULLAH ALKUHAYLI

A THESIS

Presented to the Faculty of the Graduate School of the  
MISSOURI UNIVERSITY OF SCIENCE AND TECHNOLOGY

In Partial Fulfillment of the Requirements for the Degree

MASTER OF SCIENCE IN ELECTRICAL ENGINEERING

2012

Approved by

Badrul Chowdhury, Advisor  
Mehdi Ferdowsi  
Jonathan Kimball

© 2012

Abdulaziz Abdullah Alkuhayli

All Rights Reserve

## ABSTRACT

Reliability evaluation of distribution networks, including islanded microgrid cases, is presented. The Monte Carlo simulation algorithm is applied to a test network. The network includes three types of distributed energy resources solar photovoltaic (PV), wind turbine (WT) and gas turbine (GT). These distributed generators contribute to supply part of the load during grid-connected mode, but supply the entire load during islanded microgrid operation. PV and WT stochastic models have been used to simulate the randomness of these resources. This study shows that the implementation of distributed generations can improve the reliability of the distribution networks.

## ACKNOWLEDGMENTS

I would like to take this opportunity to thank my advisor, Dr. Badrul Chowdhury, for his support, guidance and encouragement. He has always been very helpful, friendly, patient, and a great teacher.

I would also like to thank Dr. Jonathan Kimball for serving on my committee, taking time to review my thesis, and especially for advising me in my first semester.

I would also like to thank Dr. Mehdi Ferdowsi for serving on my committee, taking time to review my thesis, for being a great instructor, helping me in my application for PhD.

I would like to thank my employer King Saud University for supporting me throughout my graduate studies.

I would like to thank my wife to for her endless support, inspiration, and taking care of our two little daughters.

I would like to thank my friends in Rolla, Faris Al-Faris, Mohammed Al-Arabia, Sulatan Alqhtani, Abdulrhman Aljabbab, Ahmed Alghamdi, Abdullah Alyami, and Majed Alabbas.

Finally, I would like thank my parents for all the sacrifices that they have made in the past.

## TABLE OF CONTENTS

|   | Page |
|---|------|
| ABSTRACT.....   | iii  |
| ACKNOWLEDGMENTS .....                                 | iv   |
| LIST OF ILLUSTRATIONS.....                            | vii  |
| LIST OF TABLES.....                                   | viii |
| SECTION   |      |
| 1. INTRODUCTION.....                                  | 1    |
| 1.1. DISTRIBUTED ENERGY RESOURCES.....                | 2    |
| 1.2. MICROGRIDS.....                                  | 2    |
| 1.3. OBJECTIVE.....                                   | 6    |
| 1.4. LITERATURE REVIEW.....                           | 7    |
| 2. DISTRIBUTED GENERATION MODELS.....                 | 11   |
| 2.1. PHOTOVOLTAIC OUTPUT POWER MODEL.....             | 11   |
| 2.2. WIND TURBINE OUTPUT POWER MODEL.....             | 13   |
| 2.3. GAS TURBINE OUTPUT POWER MODEL.....              | 16   |
| 2.4. STORAGE SYSTEM.....                              | 17   |
| 3. LOAD MODEL.....                                    | 19   |
| 4. RELIABILITY INDICES.....                           | 21   |
| 4.1. AVERAGE FAILURE RATE.....                        | 21   |
| 4.2. AVERAGE INTERRUPTION TIME.....                   | 21   |
| 4.3. SYSTEM AVERAGE INTERRUPTION FREQUENCY INDEX..... | 21   |
| 4.4. SYSTEM AVERAGE INTERRUPTION DURATION INDEX.....  | 22   |
| 4.5. EXPECTED ENERGY NOT SUPPLIED.....                | 22   |
| 5. MONTE CARLO SIMULATION.....                        | 23   |
| 6. SIMULATION PROCEDURE.....                          | 25   |

|  |    |
|--|----|
| 7. CASE STUDY.....                       | 29 |
| 8. CONCLUSION.....                       | 37 |
| 9. FUTURE WORK.....                      | 39 |
| APPENDICES                               |    |
| A. WIND TURBINE OUTPUT POWER MODEL.....  | 40 |
| B. PHOTOVOLTAIC OUTPUT POWER MODEL.....  | 42 |
| C. GAS TURBINE OUTPUT POWER MODEL.....   | 45 |
| D. RELIABILITY EVALUATION OF RBTS 2..... | 47 |
| BIBLIOGRAPHY.....                        | 63 |
| VITA.....                                | 66 |



## LIST OF ILLUSTRATIONS

| Figure  | Page |
|---|------|
| 1.1 Distribution Network Containing Microgrids.....                                 | 4    |
| 1.2 Block Diagram of Energy Management System.....                                  | 5    |
| 1.3 Distribution Network for RBTS Bus 2.....  | 8    |
| 2.1 The Hourly Output Power of PV.....  | 12   |
| 2.2 PV Efficiency vs. Sunlight Intensity.....                                       | 13   |
| 2.3 Wind Turbine Power Curve.....   | 15   |
| 2.4 Hourly Output Power of Wind Turbine in a Year.....                              | 16   |
| 2.5 The Daily Generation Profile of Distributed Gas Turbine.....                    | 17   |
| 2.6 Hourly Charge and Discharge Profile of the Storage.....                         | 18   |
| 3.1 Monthly Weight Factor.....  | 19   |
| 3.2 Hourly Weight Factor.....   | 20   |
| 5.1 Element Operating/Repair History.....   | 24   |
| 6.1 Flowchart of Distribution System Reliability Evaluation Without Microgrids..... | 27   |
| 6.2 Flowchart of Distribution System Reliability Evaluation with Microgrids.....    | 28   |
| 7.1 Distribution System for RBTS Bus 2 Containing Microgrids.....                   | 29   |
| 7.2 Failure Rate of All Load Points.....  | 32   |
| 7.3 Average Interruption Time of All Load Points.....                               | 34   |
| 7.4 Average Interruption Energy of All Load Points.....                             | 35   |

**LIST OF TABLES**

| Table   | Page |
|---|------|
| 7.1 Feeder Lengths.....                               | 30   |
| 7.2 Load Points Data.....                             | 30   |
| 7.3 Reliability Indices of Distribution Elements..... | 30   |
| 7.4 The Monthly Light Intensity.....                  | 31   |
| 7.5 The Wind Velocity and Wind Turbine Data.....      | 31   |
| 7.6 Reliability Indices of RBTS Bus2.....             | 35   |

## 1. INTRODUCTION

In recent years, researchers in the field of power systems engineering have become interested in the implementation of renewable energy resources in power networks. This interest is motivated by environmental issues and rising fossil fuel prices. Since greenhouse gas emissions are the main cause of global warming, using technologies that do not produce Carbon Dioxide emissions would naturally eliminate their effects. Rising fossil fuel prices have made renewable resources more competitive in the market and could encourage more technologies to compete in the power market. For example, plug-in hybrid electric vehicles that are predicted to reshape the transportation future, could interact with power grids as a means of energy storage. Alternative energy can be used to supply these vehicles, and this would reduce the dependency on fossil fuels.

Distributed energy resources take different forms such as wind, solar, geothermal, etc. The United States Department of Energy (DOE) has established a new project called SunShot. This project aims to reduce the solar energy cost by 75% by 2020. In addition, SunShot plans to extend the solar energy generation to reach 15-18 % of the United States' electricity generation capacity by 2030 [1]. In 2011, Germany's PV installed capacity reached about 24 gigawatts (GW) [2]. In 2011, Italy installed 9.3 GW of PV generation capacity which made it the top PV market in that year. Germany and Italy accounted for 59% of Global PV installed capacity. China reached its first GW of PV capacity by installing 2.2 GW in 2011 [3].

The title of an ambitious plan which is supported by the United States government is “20 Percent Wind Energy by 2030 [4]. In 2007, 30 per cent of the installed capacity in

the United States was wind generation. China is massively expanding its wind generation capacity which reached 45 GW in 2010 [5]. Germany reached 30 GW of wind installed capacity generation in 2011[6]. In Spain, 1.5 GW of wind capacity were installed in 2010 and the total capacity has reached 20.5 GW [6].

### **1.1. DISTRIBUTED ENERGY RESOURCES**

In typical power networks, the electricity is generated by large-scale power plants and transported via the transmission and distribution networks to end users. This concept is called centralized generation. Distributed generation or decentralized generation is an approach that implements small-scale generators installed on the low-voltage networks by the customers or the utility companies. The advantages of employing this technology in power systems include:

- Reduction in power losses caused by the power traveling through long transmission lines and high voltage transformers.
- Relieving the congested transmission networks and reducing the need to expand transmission networks.
- Enabling consumers to select the source of energy based on the cost and awareness of the environmental issues.
- Improving the reliability of the power service by providing an alternative source during power disturbance events.

### **1.2. MICROGRIDS**

In the traditional centralized generation version of power networks, the distribution networks are radial that allow the power to flow in one direction. However,

high penetration of distributed generation could change this practice, and more new technologies must be adopted on the distribution networks to prepare power grids to accept high levels of distributed generations. This is explained next.

The microgrids concept is associated with the distribution networks that contain one or more micro generators. The implementation of microgrids would reshape distribution engineering on different aspects such as protection, control and communication systems. Also, microgrids can be operated in an interconnected mode where the distributed generation contributes with power grid to supply the load, or, in an islanded mode where the loads are supplied by the distributed generation only. The integration of microgrids in power systems would pave the way for high penetration of intermittent resources such as wind and solar energy. Figure 1.1 shows an example of a microgrid in a distribution network. Since the breaker is open, microgrid 1 is isolated from the system and operated in island mode. Microgrid 2 is interconnected with the grid where the loads are supplied by the distributed generation and the main grid.

In a conventional distribution network, the power flow is radial which needs simple protection devices such as fuses, unidirectional overcurrent relays and reclosers. These devices don't fulfill the microgrid protection and does not offer the desired flexibility. Different configurations of distribution networks result in changing the short circuit levels which are caused by changing system impedance. In addition, bidirectional power flow is expected in operating distribution networks containing microgrids. For these reasons, protection systems must be reengineered to handle different operating modes. One of the promising features of microgrids is the capability to perform

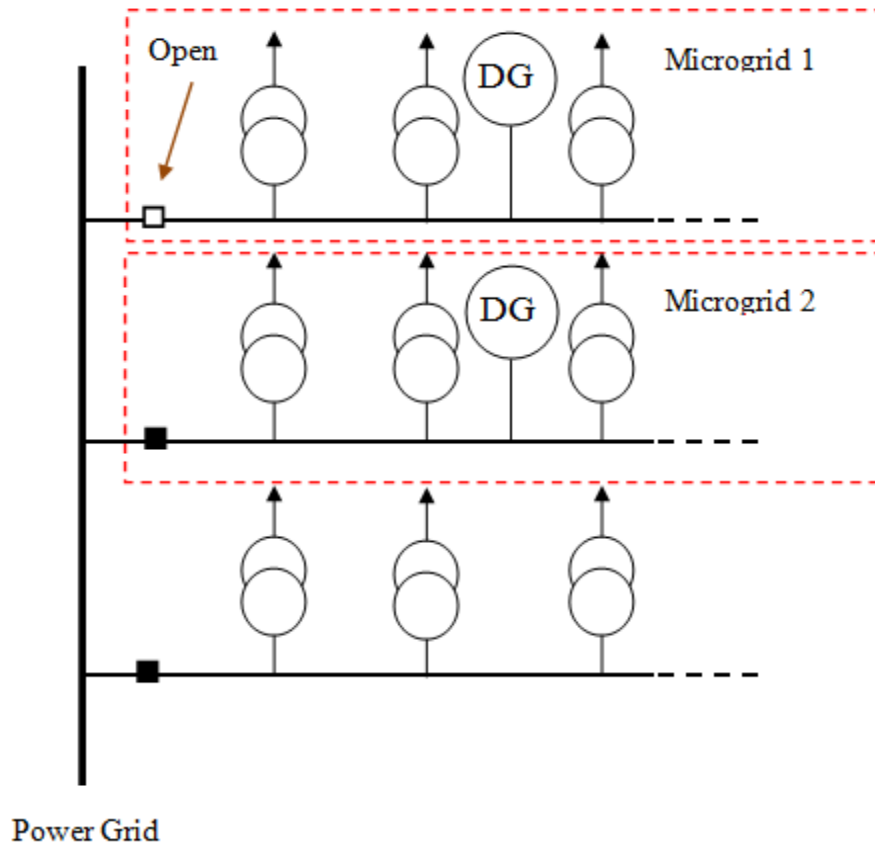

Figure 1.1 Distribution Network Containing Microgrids

autoconfiguration of distribution networks without the interaction of networks operators [7]. This feature makes microgrids self-healing from network components failure or power disturbances, and this will result in fewer interruptions leading to higher reliability. The use of power electronic-based or static switches would provide the protection and control systems of microgrids with faster response compared to convention mechanical circuit breakers [8].

Since the load and distributed generation from renewable resources variable in nature, energy management systems could be useful tools to allocate energy resources

and control power production. Live data needs to be collected and exchanged between within the system. These include, weather, load demand, power production and power outages. Therefore, two lines of communication should be installed in the distribution networks. The energy management system's function is to process the data and achieve an efficient operation of the network with consideration of economic dispatch and system reliability. Figure 1.2 shows an example of a simplified block diagram of energy management system in a distribution network.

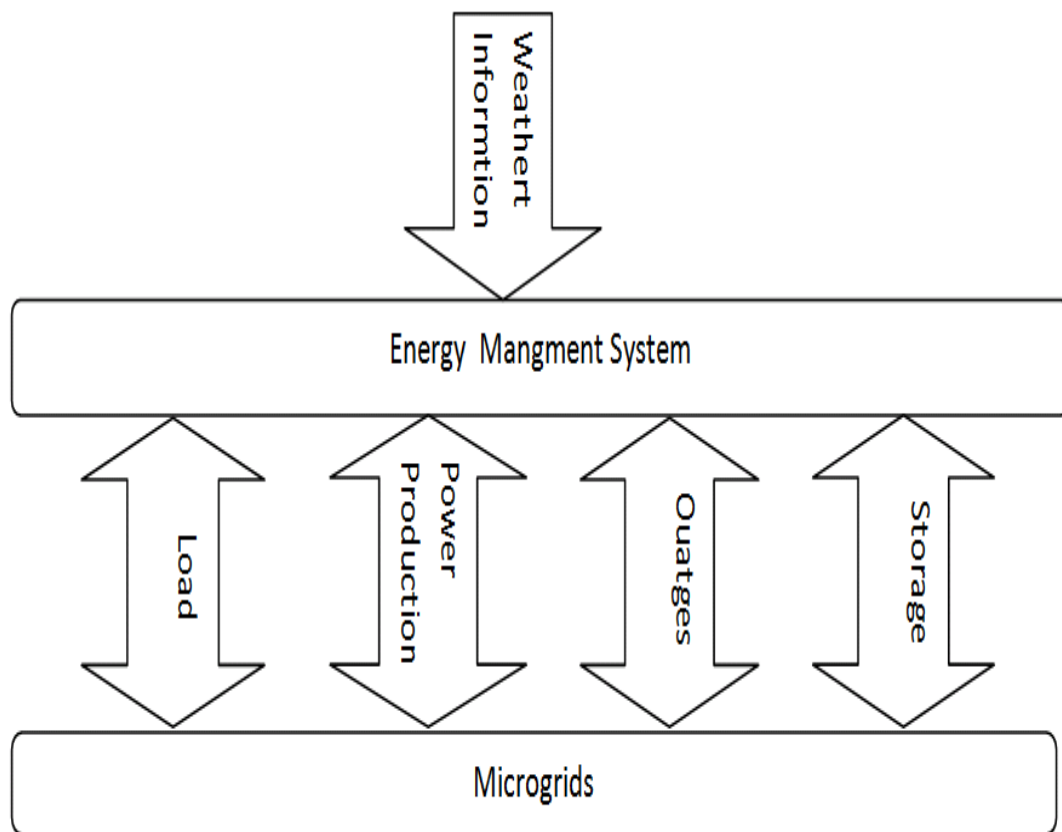

Figure 1.2 Block Diagram of Energy Management System

### 1.3. OBJECTIVE

The reliability of power networks is a major concern for utility companies and consumers. The reliability or availability term refers to the ability of the system to provide continuous service to end users regardless of any failures in the power network.

Most power companies operate their generation and transmission equipment in N-1 or N-2 criterion [9]. This means that if one piece of transmission equipment (transformer, lines, reactor) or generator goes out of operation in N-1 criterion, the system will be able to tolerate this outage without any shortage in power delivery to consumers. It is very important to have an additional capacity in transmission and generation because a shortage of the capacity or failure in these parts of the network can affect large numbers of customers. Due to the fact that distribution circuits are long and the large number of transformers in this part of the network are in contrast to transmission network, N-0 criterion is widely practiced in radial low voltage distribution networks. Therefore, power service would be interrupted when the main components of distribution networks go out. For this reason, the reliability evaluation of distribution networks have drawn the attention of researchers.

There are two main techniques to evaluate the reliability of power systems. The first is the analytical technique which requires a series of mathematical calculations with an approximation in the case of a complex system. In this thesis, Monte Carlo Simulation (MCS) has been proposed for the purpose of reliability evaluation of the distribution network containing microgrids which is a simulative technique. The MCS is widely used in power system studies such as probabilistic power flow, economic dispatch and reliability evaluations [12], [13]. Distribution system reliability evaluation based on



MCS is very useful in complex non-linear systems. This method yields more information on the load point and system reliability indices compared to the analytical method.

Because of the uncertainty of both wind turbine and photovoltaic output power, it is not easy to use the analytical method to evaluate reliability of a system contains these recourses. However, the output power of WT and PV can be predicted by generating a large number of scenarios in desired time. Therefore, using Monte Carlo simulations to simulate the output power of WT and PV can be used to avoid complexities of the analytical method.

A distribution system for RBTS Bus 2 containing four microgrids is used to test the methodology used in this research. In order to make it easier in coding, the sections have been relabeled. The RBTS Bus 2 and Bus 4 are widely used in reliability evaluations of distribution networks studies [10], [11]. These systems are small, and they can be easily analyzed. In addition, they offer sufficient data to conduct reliability studies without the need to power flow analysis. Figure 1.3 shows the distribution system for RBTS Bus 2.

The impact of implementing renewable distributed generation, storage systems, and conventional generation on the reliability of distribution network is studied. To evaluate the reliability of distribution networks containing PV and WT generations, stochastic models have to be built to deal with the uncertainty of these resources.

#### **1.4. LITERATURE REVIEW**

Billiton, et al. [14] have developed a reliability test system for educational purposes which is called the Roy Billiton Test System and is abbreviated as RBTS. The RBTS contains 5 busbars (Bus2-Bus6) [15]. Bus2 and Bus4 are widely used i

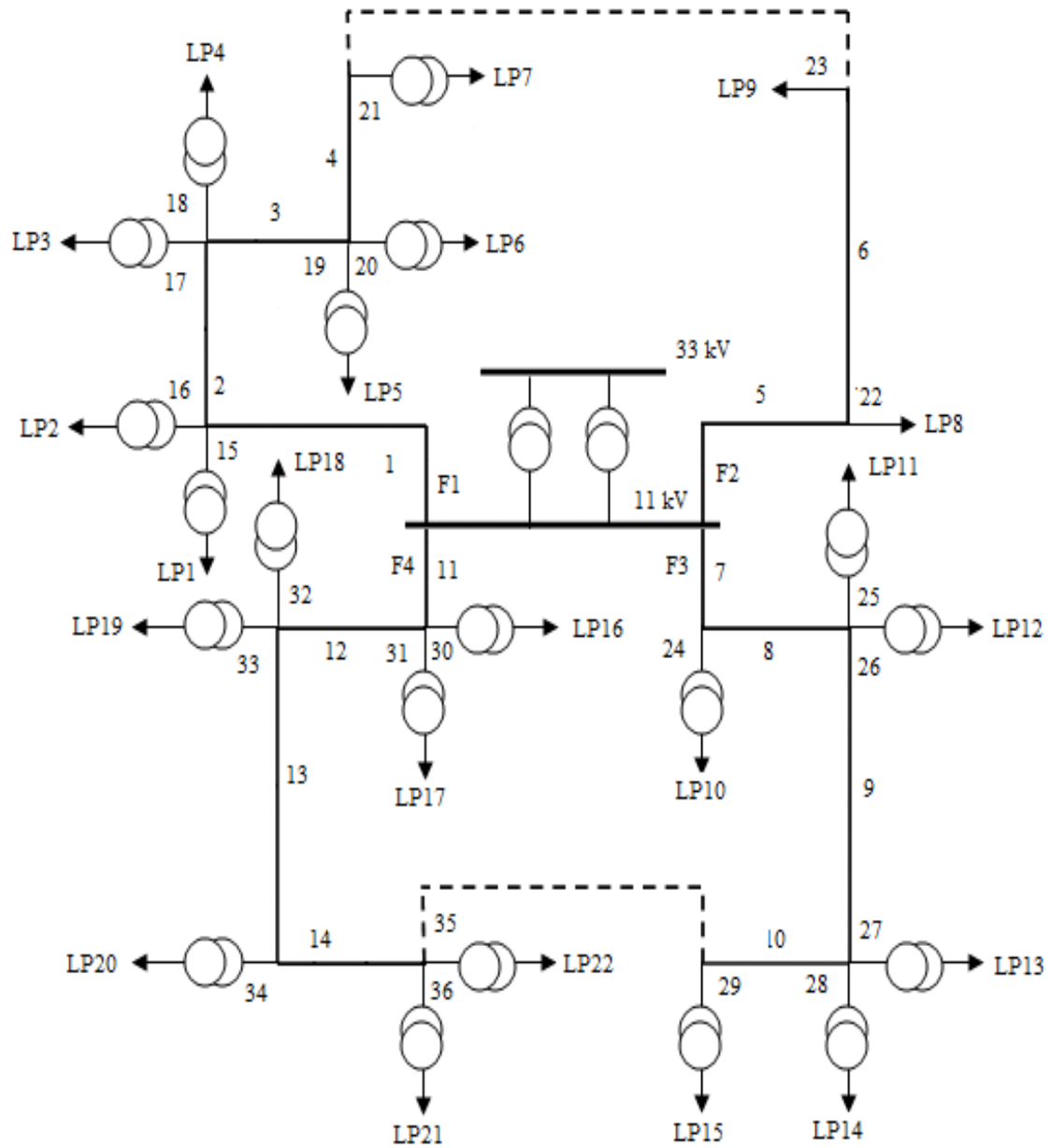

Figure 1.3 Distribution Network for RBTS Bus 2

reliability evaluation of distribution networks because they offer detailed information on distribution system components such as failure rate and average repair time for overhead lines and underground cables systems.

Reliability assessment of distribution networks with distributed generation has drawn attention of researchers in power systems engineering. Many researchers have analyzed distribution systems with renewable resources such as solar and wind energy. In order to implement these resources in reliability studies, a stochastic model of output power must be used. Output power models of stochastic energy resources such as solar radiation and wind energy have been developed by A.K David [16]. His work represents probabilistic methods to predict the fluctuation of these resources for the purpose of reliability studies in power systems. Khallat and Rahman in [17] have studied three different methods to predict the output power of photovoltaic systems, which are Normal, Weibull and Beta distribution. They have compared the obtained results in different seasons from these methods and recommended using Beta and Weibull to represent the intermittency of the solar insolation depending on the desired time. Sutoh, Suzuki and Sekin have developed a probabilistic model of PV output power [18]. Their model represents the average and the variance of the output power of PV. Meteorological data has been collected and compared with the results that were obtained from the model which has proven that the variance of the output power obeys a normal distribution.

In order to develop a reliability model for a wind generator, the intermittency of the wind velocity must be considered in this model to obtain realistic results. Giorsetto and Utsurogi in [19] have developed a method to evaluate the impact of implementing wind turbine on the reliability of the system. They include the effects of forced outage of the wind turbine and the variable wind velocity on the overall reliability by using a probabilistic method. Wang, Dai and Thomas in [20] have studied the impact of wind turbine generators on the reliability of power systems and developed a model which deals

with failure rate of the generators and the associated equipment with it such as DC/AC convertor. Weibull distribution is used to generate the hourly wind velocity. Karki, Hu and Billinton in [21] have taken into account geographical locations of the wind power generation when they developed their wind reliability model. Actual Statistical Data is compared with simulated data of wind speeds in different locations in Canada, and the results were very close.

Billinton and Wang in [22] have developed an algorithm to evaluate the reliability using MCS to be used in complex distribution networks. The program was used on the distribution system of the RBTS, and the obtained results were very close to the analytical method. Reliability evaluation of distribution networks containing microgrids have been studied by Bea and Kim in two cases [10]. The load duration curve model was used in the one case and the peak load was used in a second case to investigate the impact of the load profile on system reliability. The results show that implementing load peak data in reliability studies would give misleading reliability indices. Huishi, Jian and Sige in [11] have investigated the impact of the distributed generations and storage systems on the distribution system reliability. The storage system model was developed and implemented to smooth the fluctuations of the output power of renewable resources.

## 2. DISTRIBUTED GENERATION MODELS

In this study, the reliability of distribution system containing renewable resources such as wind and solar energy was assessed. It is well known that due to the fact that solar insolation and wind speeds are both intermittent, the output powers of PV and WT systems are not deterministic. That brings up the need for a stochastic model to simulate PV and WT outputs. The stochastic model is a simulation-based technique to describe a non-deterministic behavior and the randomness of the system. The probability distribution, therefore, can be used to predict the output power of PV and WT. In order to find statistical data of the wind speed and solar insolation, meteorological data of a variety of weather conditions at one location must be measured. In this study, the distribution system contains distributed gas turbines (DGT's). The output power of the DGT's is modeled. The storage systems is needed to decrease the peak load since the peak of the output power of the PV's and the peak load do not occur at the same time in most load profiles.

### 2.1. PHOTOVOLTAIC OUTPUT POWER MODEL

The sunlight intensity or insolation  $I(t)$  and solar panel area ( $S$ ) have a great impact on PV output power. The intensity of sunlight varies from month to month and reaches the peak during the summer as shown in Figure 2.1 For the sake of the simplicity, a simple model of PV is investigated in this research.

The output power of the PV system can be calculated by the following equation [27]:

$$P_{out} = \begin{cases} \frac{\eta_c}{K} * S * I(t)^2 & 0 < I(t) \leq K \\ \eta_c * S * I(t) & I(t) > K \end{cases} \quad (1)$$

Where  $\eta_c$  is the efficiency of the PV system.  $K$  is a threshold.

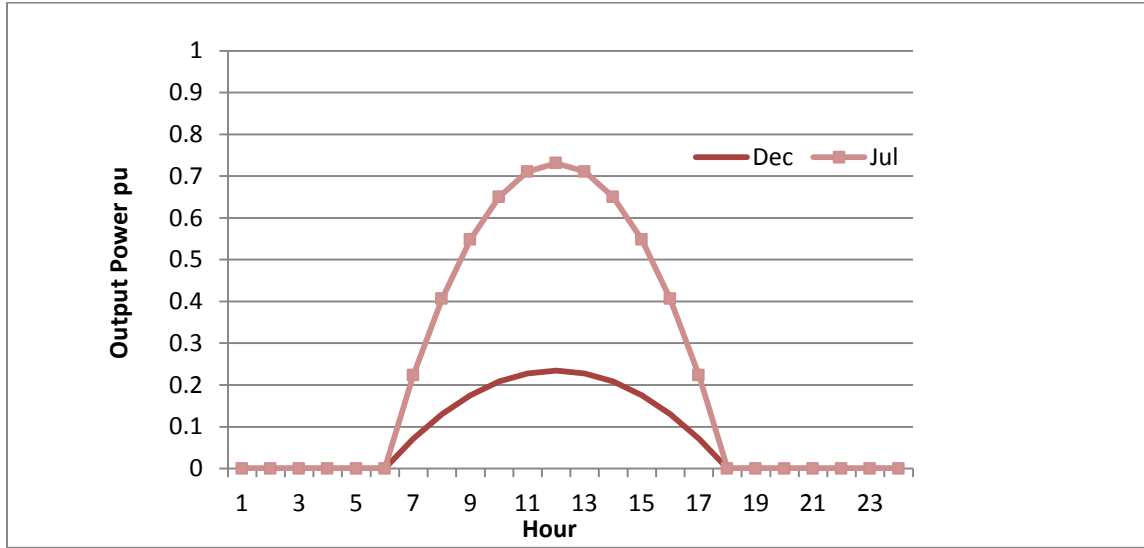

Figure 2.1 The Hourly Output Power of PV

The value of  $\eta_c$  is not a constant when  $I(t)$  is less than or equal  $K$ . However, when  $I(t)$  exceeds  $K$ ,  $\eta_c$  is almost constant. Figure 2.2 shows the relation between  $I(t)$  and  $\eta_c$ . For a typical sunny day, the hourly solar insolation  $I(t)$  can be expressed by the following equation [11]:

$$I(t) = \begin{cases} I_{max} \left( -\frac{1}{36} t^2 + \frac{2}{3} t - 3 \right) & 6 \leq t \leq 18 \\ 0 & 0 \leq t < 6 \text{ and } 18 \leq t \leq 24 \end{cases} \quad (2)$$

The solar insolation can be affected by several factors such as clouds, temperature, and relative humidity. To make the PV model more realistic, a prediction tool should be implemented. Studies have proven that the variation of PV output power ( $\Delta P_{out}$ ) follows a normal distribution [23]. Therefore,  $\Delta P_{out}$  can be expressed by the following equation [23]:

$$f(\Delta P_{out}) = \frac{1}{\sqrt{2*\pi}} * \exp\left(-\frac{\Delta P_{out}^2}{2*\sigma_{PV}^2}\right) \quad (3)$$

Where  $\sigma_{PV}$  is the variance of PV output power.

The predicted PV output power includes  $P_{out}$  on a sunny day plus  $\Delta P_{out}$ . Thus, the PV output can be calculated by the following equation [23]:

$$P_{PV} = P_{out} + \Delta P_{out} \quad (4)$$

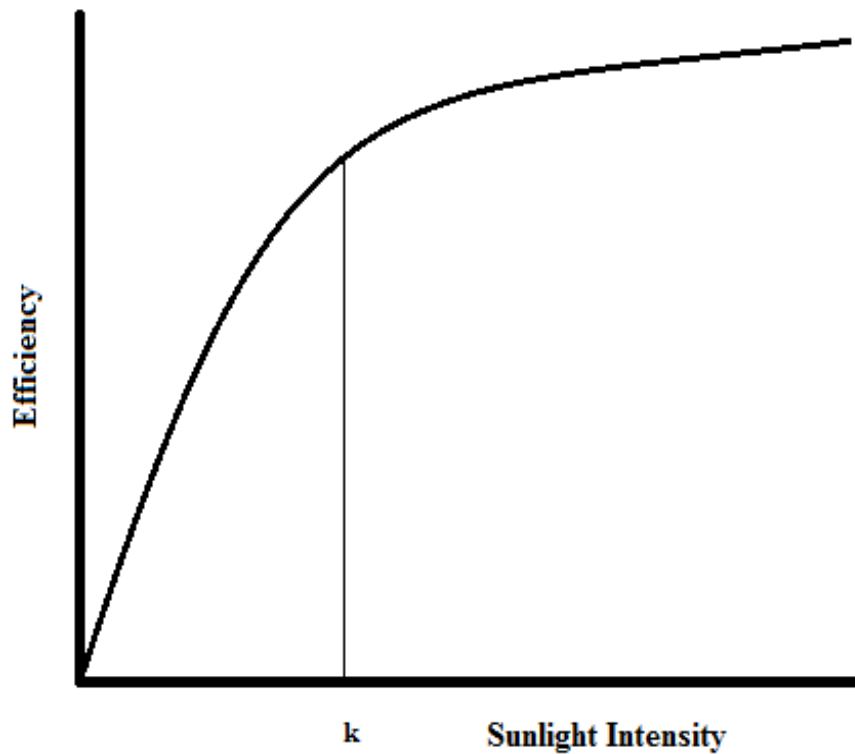

Figure 2.2 PV Efficiency vs. Sunlight Intensity

## 2.2. WIND TURBINE OUTPUT POWER MODEL

The output power of a wind turbine depends on wind velocity. If the wind velocity is below the cut-in speed, there is no enough power to generate power, and the

wind turbine would be tuned off. If the wind velocity is between the cut-in and rated speed, the output power would be variable. If the wind velocity is between the rated and cut-on speed, the output power would be constant. In the case of the wind speed goes above cut-on speed, the wind turbine would be turned off because it exceeds the mechanical safety limit. The relationship between the output power and wind velocity is shown in Figure 2.3, and can be expressed as [19]:

$$f(x) = \begin{cases} 0 & 0 \leq V_t \leq V_{ci} \\ (A + B \cdot V_t + C \cdot V_t^2) P_r & V_{ci} \leq V_t \leq V_r \\ P_r & V_r < V_t \leq V_{co} \\ 0 & V_t > V_{co} \end{cases} \quad (5)$$

Where

$P_r$  rated power output

$V_{ci}$  cut-in wind speed

$V_r$  rated wind speed

$V_{co}$  cut-out wind speed

A, B, and C are constants, and can be calculated as functions of  $V_{ci}$  and  $V_r$  as [19]:

$$A = \frac{1}{(V_{ci} - V_r)^2} \left( V_{ci}(V_{ci} + V_r) - 4V_{ci}V_r \left( \frac{V_{ci} - V_r}{2V_r} \right)^3 \right) \quad (6)$$

$$B = \frac{1}{(V_{ci} - V_r)^2} \left( 4(V_{ci} + V_r) \left( \frac{V_{ci} + V_r}{2V_r} \right)^3 - (3V_{ci} + V_r) \right) \quad (7)$$

$$C = \frac{1}{(V_{ci} - V_r)^2} \left( 2 - 4 \left( \frac{4*V_{ci} + V_r}{2V_r} \right)^3 \right) \quad (8)$$

Wind speed is intermittent by nature, and this will result in variations in output power. Consequently, a probabilistic method should be implemented to simulate the uncertainty of the wind speed. Statistical data has shown that probability distribution of wind speed follows a Weibull distribution [24], [25]. The probability density



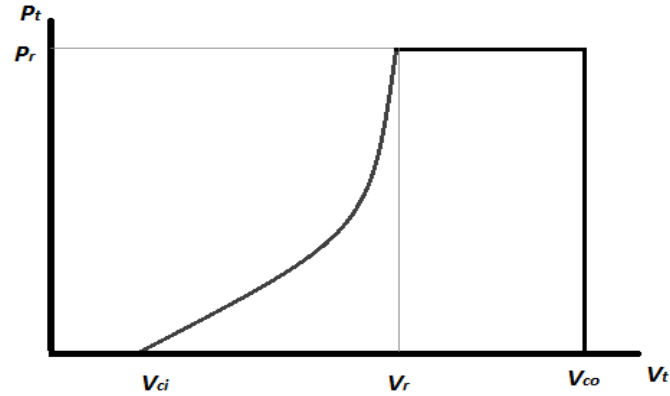

Figure 2.3 Wind Turbine Power Curve

function of a two parameter Weibull distribution is given as [26]:

$$f(v) = \frac{k}{c} \left(\frac{v}{c}\right)^{k-1} \exp\left[-\left(\frac{v}{c}\right)^k\right] \quad (9)$$

Where

$v$  wind speed

$c$  scale parameter

$k$  shape parameter

Both  $c$  and  $k$  can be expressed as functions of average ( $\mu$ ) and standard deviation ( $\sigma$ ) of wind velocity. To find the shape parameter, approximation was used [4].  $k$  can be calculated by the following equation [26]:

$$k = \left(\frac{\sigma}{\mu}\right)^{-1.086} \quad (10)$$

After finding  $k$ ,  $c$  can be calculated by the following equation [26]:

$$c = \frac{\mu}{\Gamma(1+1/k)} \quad (11)$$

Since the Weibull probability function of the wind speed is very sensitive to any change in  $c$  and  $k$ , statistical data of the wind speed at the desired location should be collected for several years. The hourly output power of the wind turbine model in one year is shown in Figure 2.4. It is observed that the output power of the wind turbine is variable throughout the year.

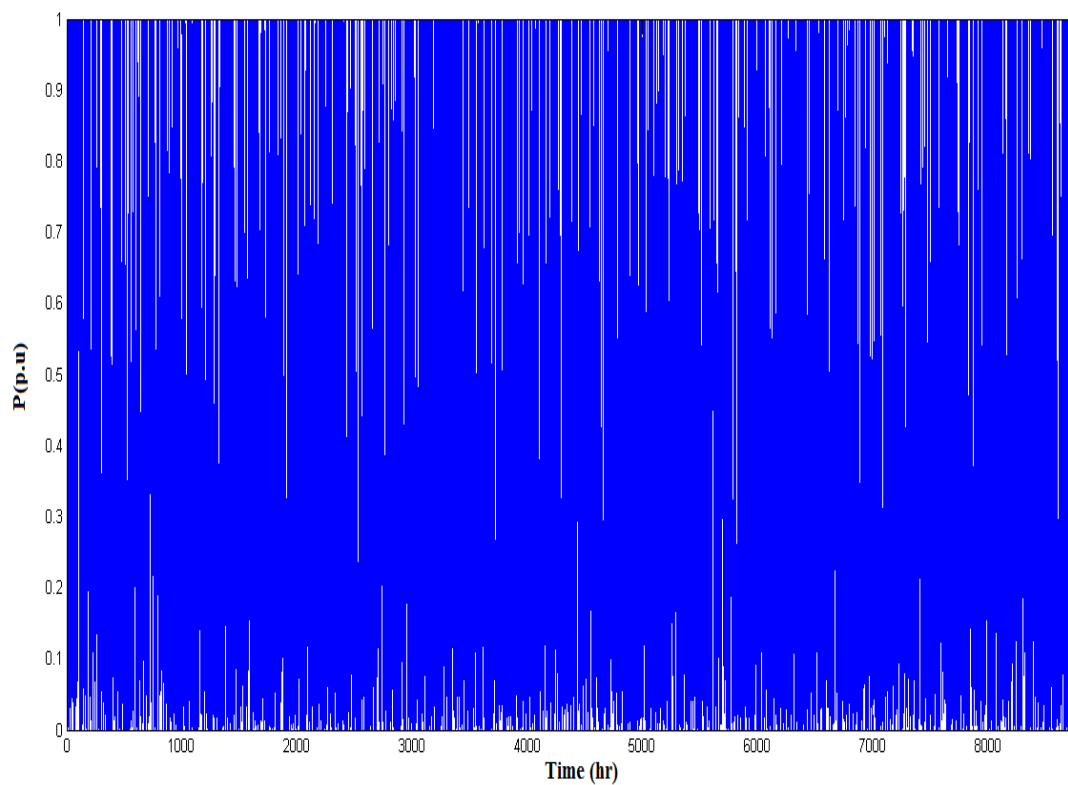

Figure 2.4 Hourly Output Power of Wind Turbine in a Year

### 2.3. GAS TURBINE OUTPUT POWER MODEL

Gas turbine generators (GT's) are widely used in distribution networks. In some cases, GT's are used as back-up source, especially with critical loads or they are

associated with the main grid to supply the load during the peak time. GT is a very reliable source of energy with low rates of failure. Its output power is predictable. Thus, developing an output power model of gas turbine is very simple and depends on the operation hours. In this study, GTs operates for 5 hours in normal conditions, or when there is a shortage from the main grid. In this study, the peak load time occurs between 4:00 pm and 8:00 pm based on the load profile, which will be demonstrated in Section 3. Figure 2.5 shows the generation profile of a GT.

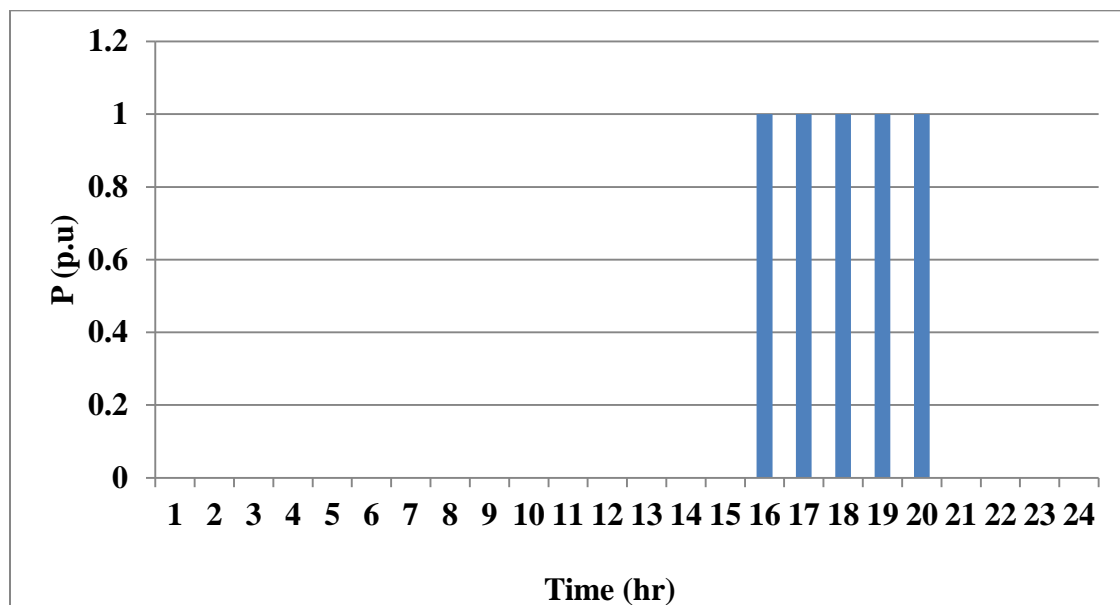

Figure 2.5 The Daily Generation Profile of Distributed Gas Turbine

## 2.4. STORAGE SYSTEM

A storage system can be used with a photovoltaic unit to smooth the fluctuation of the PV output power and shave the peak load by reducing the demand. In addition,

battery storage can associate with the distributed energy resources to supply the load when the main source is not available. In this thesis, a generic battery storage system is developed, which serves the main purpose of this study.

The battery system capacity and the converter capacity are 0.75 MWh and 0.3 MW respectively. Figure 2.6 shows the hourly charge and discharge profile of the battery. From 2:00 am to 6:00 am, the storage draws 0.15 MW continuously to charge the batteries because this time is considered to be off- peak (based on the load profile). From 4:00 pm to 8:00 pm, the storage system is discharged to supply the load during the peak. Because there is no output power of the PV during the night, the storage battery is charged by the main grid. During interruptions in the power network, the load can draw up to 0.3 MWh of energy in 2.5 hours if the battery is fully charged.

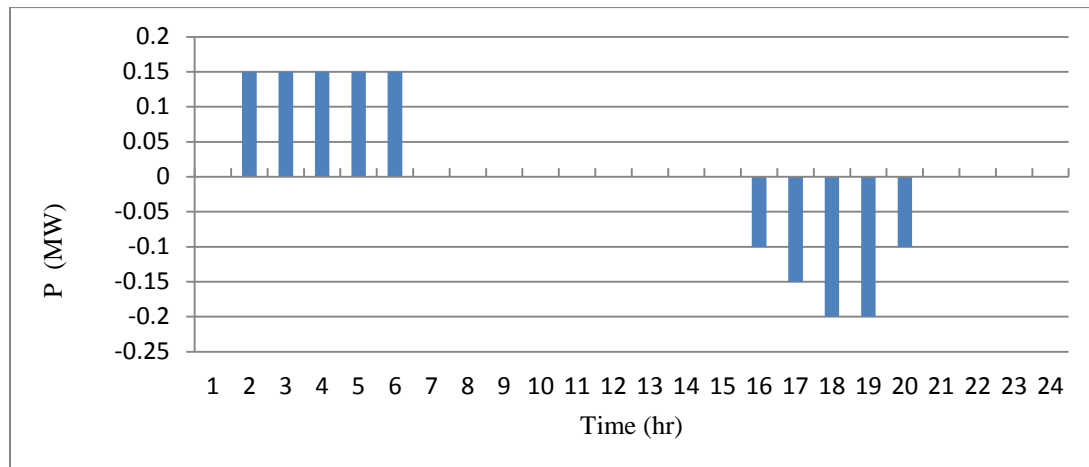

Figure 2.6 Hourly Charge and Discharge Profile of the Storage ( $P > 0$  Charging and  $P < 0$  Discharging)

### 3. LOAD MODEL

Weather conditions and seasonal events affect the load. Fortunately, most of these events take place at the same time annually. Therefore, the behavior of power system loads is a frequent pattern during normal conditions. A time varying load model can be developed by using historical data. Monthly and hourly weight factor data are used to construct a load model. Figures 3.1 and 3.2 show monthly and hourly weight factors [28]. Equation (12) can be used to find the predicted load for load point  $i$  at any desired time.

$$P_i(t) = w_h(h) \times w_m(m) \times P_{Li} \quad (12)$$

Where

$w_h(h)$  hourly weight factor

$w_m(m)$  monthly weight factor

$P_{Li}$  peak load for load point  $i$

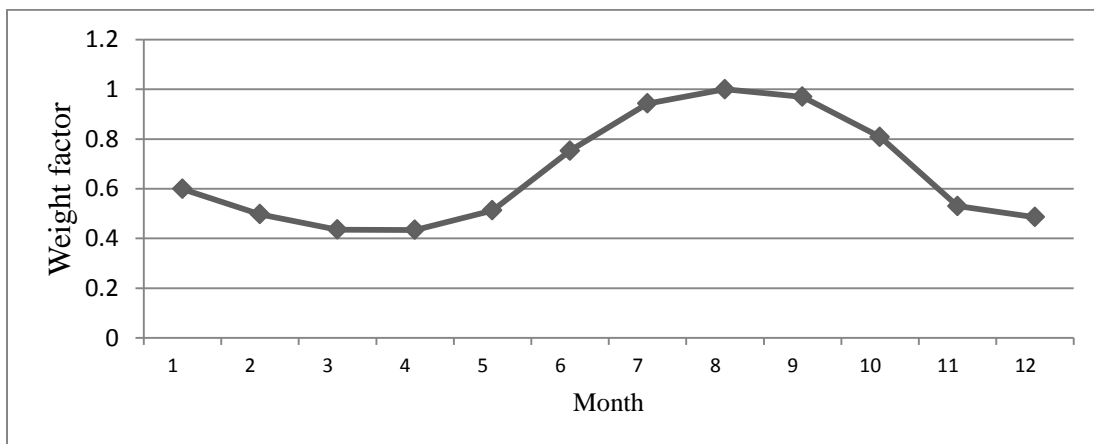

Figure 3.1 Monthly Weight Factor

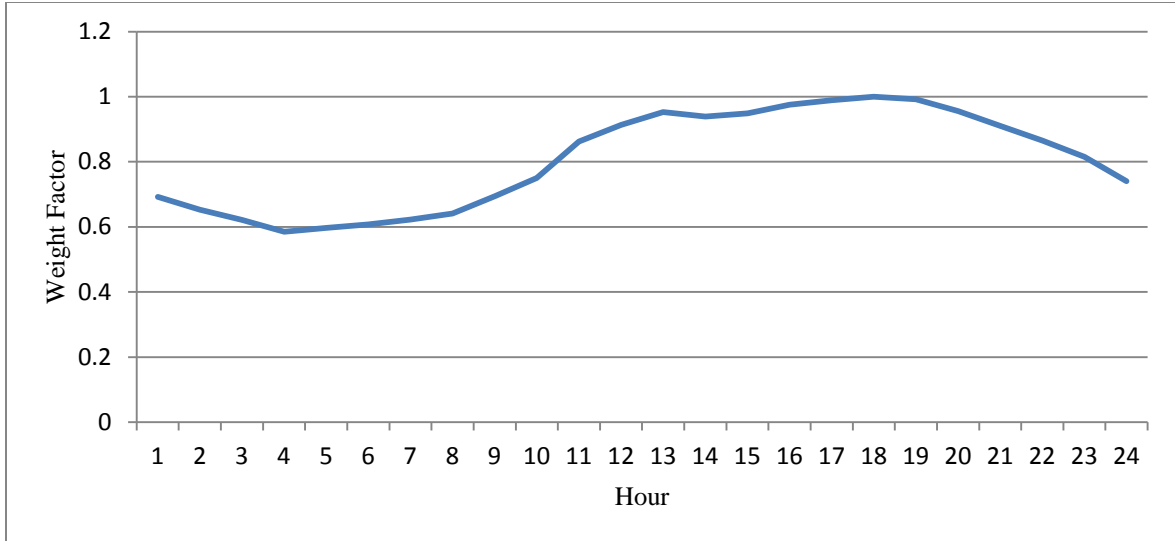

Figure 3.2 Hourly Weight Factor

## 4. RELIABILITY INDICES

Mostly, forced interruptions in power service are included in reliability evaluation. These interruptions occur due to the failure of network components. In this study, some common indices are used to evaluate the reliability of power networks. These include SAIFI, SAIDI, and EENS. These indices can be defined as functions of average failure rate over the total number of customers, and average interruption time.

### 4.1. AVERAGE FAILURE RATE

The average failure rate  $\lambda$  is defined as the probability of failure occurrence during a specific period for load point [29], which can be given by

$$\lambda = \sum_{i=1}^n \lambda_i \quad (13)$$

Where  $\lambda_i$  is the failure rate of the series components from the source point to load point.

### 4.2. AVERAGE INTERRUPTION TIME

The average interruption time  $U$  is defined as the average interruption time of load point in a specific period [29], which can be expressed as:

$$U = \sum_{i=1}^n \lambda_i r_i \quad (14)$$

Where  $r_i$  is average restoration time of network component  $i$ .

### 4.3. SYSTEM AVERAGE INTERRUPTION FREQUENCY INDEX

SAIFI measures the number of permanent interruption that customers would experience in one year [29], which can be calculated by Eq. (15).

$$SAIFI = \frac{\sum_{i=1}^n \lambda_i N_i}{\sum_{i=1}^n N_i} \quad (15)$$

Where  $N_i$  is number of customers per load point.

#### 4.4. SYSTEM AVERAGE INTERRUPTION DURATION INDEX

SAIDI measures the duration of permanent interruption that customers would experience in one year [29], which can be calculated by the following equation:

$$SAIDI = \frac{\sum_{i=1}^n U_i N_i}{\sum_{i=1}^n N_i} \quad (16)$$

#### 4.5. EXPECTED ENERGY NOT SUPPLIED

EENS measures the total of energy interruption that customers would experience in one year [29]. It can be calculated by Equation (17).

$$EENS = \sum_{i=1}^n E_i \quad (17)$$

Where  $E_i$  is the average of average interruption energy per load point.



## 5. MONTE CARLO SIMULATION

Due to the fact that failures in power systems are random in nature, MCS can be used to simulate these failures. MCS is a probabilistic method that can be used to predict the behavior of the system components. Time sequential simulation is one of the MCS types used when the system behavior depends on past events.

An artificial history is needed in time sequential simulation, and this can be obtained by generating the up and down times randomly for the system components. Time to failure (TTF) is the duration that it would take the component to fail. This time is predicted randomly by the following equation [29]:

$$TTF = -\frac{1}{\lambda} \ln(n) \quad (18)$$

Where  $\lambda$  is failure rate of system component and  $n$  is a random number (range from 0 to 1).

Time to repair (TTR) or Time to replace (TTR) is the time required to repair or replace a failed components. Also, this time is predicted randomly by the following equation [29]:

$$TTR = -\frac{1}{\mu} \ln(n) \quad (19)$$

Where  $\mu$  is repair rate of system component.

It is obvious from Equations (18) and (19) that TTF and TTR follow exponential distributions. To predict the artificial history of system components, TTF and TTR can be generated to cover simulation times (e.g. 1 year) in chronological order. Figure 5.1 shows an example of component operating history. In order to obtain an accurate result, MCS have to be performed for a large number of scenarios, and the simulation time can be expanded to be a very long time (e.g 1000 years or more) depending on the case study

and the desired accuracy. After that, the average can be calculated. In this study, the simulation is performed for a time period of one year and 10000 cases.

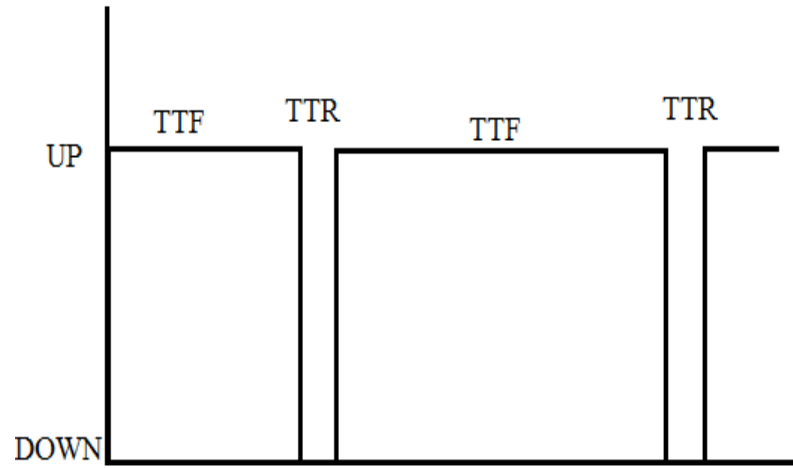

Figure 5.1 Element Operating/Repair History

## 6. SIMULATION PROCEDURE

In this study, two reliability evaluation algorithms are used. The first algorithm is for a distribution network that does not contain microgrids, and the second is for a distribution network containing microgrids. The results from the algorithms give a clear vision of how DGs can impact the reliability. MCS is performed on RBTS Bus 2 system with developed stochastic DGS models to simulate the uncertainty of these resources. Matlab has been used to develop the programs which are shown in the Appendix of this thesis.

Since the main purpose of this study is to evaluate the reliability of distribution systems containing microgrids, the following assumptions were made which should not have a significant effect on the results:

- Only primary main feeder failures are included in the analysis.
- Only permanent faults are included in the study.
- All protection devices operate successfully to isolate faults.
- Each section is protected by a breaker to isolate faults.
- It takes 1 hr to transfer loads from the failed feeder to a neighboring feeder through a normal operating point.
- Each circuit breaker is controlled by a bi-directional protection device.

The following steps are the simulation procedures of reliability evaluation of distribution networks containing distributed generation :

- i. Generate the time to failure for each distribution component using Equations (18).

- ii. Generate the operating/ repair history for each distributed generator using Equations (18) and (19).
- iii. Check the time to failure of one of distribution complement is less than 8760 hr, if no one go to step i.
- iv. Select the distribution component that has the least time to failure.
- v. Find the affected load points connected to the failed feeder, and divide it to two groups. First group, load points can be restored. Second group, load points cannot be restored.
- vi. Generate the time to repair and determine interruption energy for group one.
- vii. Determine the total power of distributed generator that connected to failed feeder by using DG model feeder, and determine the total load of group 2.
- viii. If total power generation is greater than or equal the total load of group 2, go to step x
- ix. Generate the time to repair and determine interruption energy for group one.
- x. Find the distribution component that has next smallest time to failure. If it is less than 8670, go to v or go to xi if not.
- xi. Repeat steps i-x until reached the maximum number of cases
- xii. Determine SAIFI, SAIDI, and EENS by using the Equations (15), (16), and (17) respectively.

Figures 6.1 and 6.2 show the algorithms of distribution system reliability evaluation indices with and without microgrids respectively.

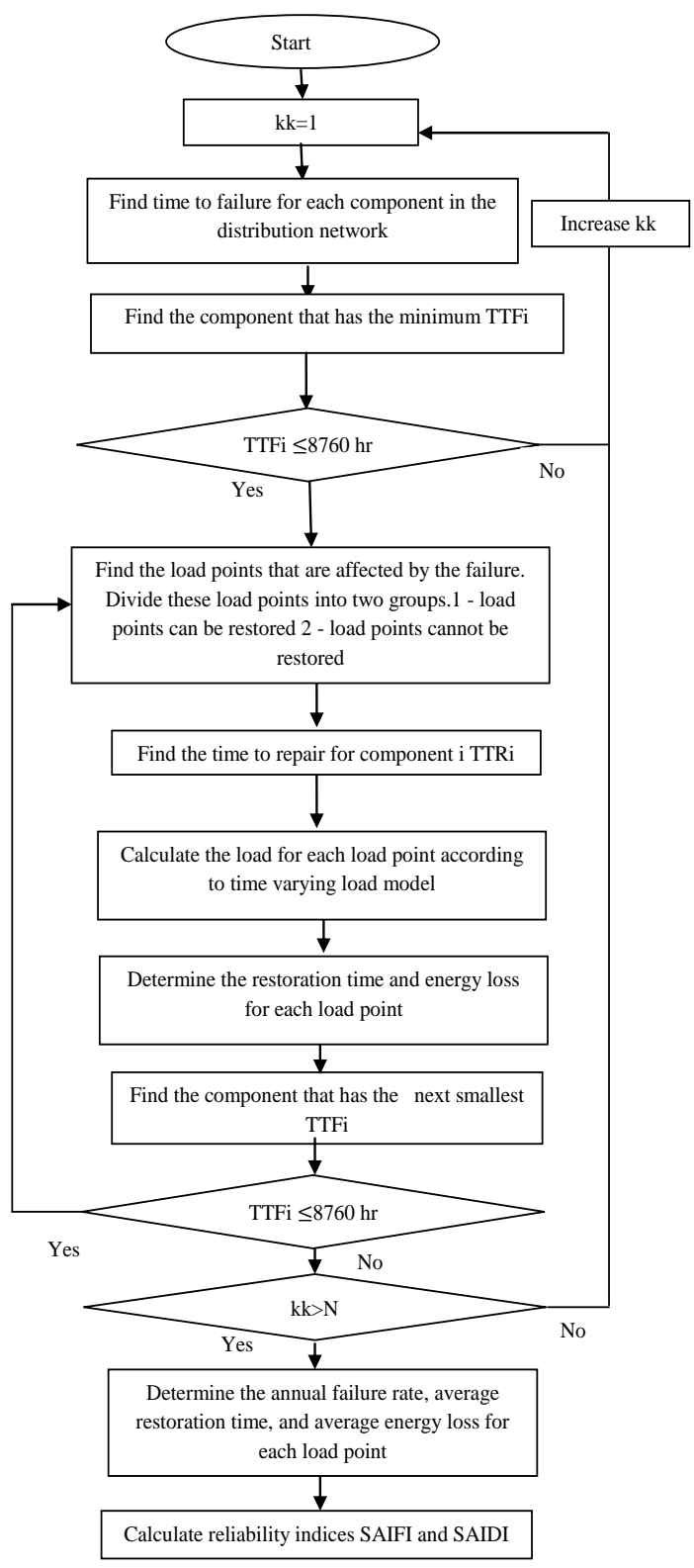

Figure 6.1 Flowchart of Distribution System Reliability Evaluation Without Microgrids

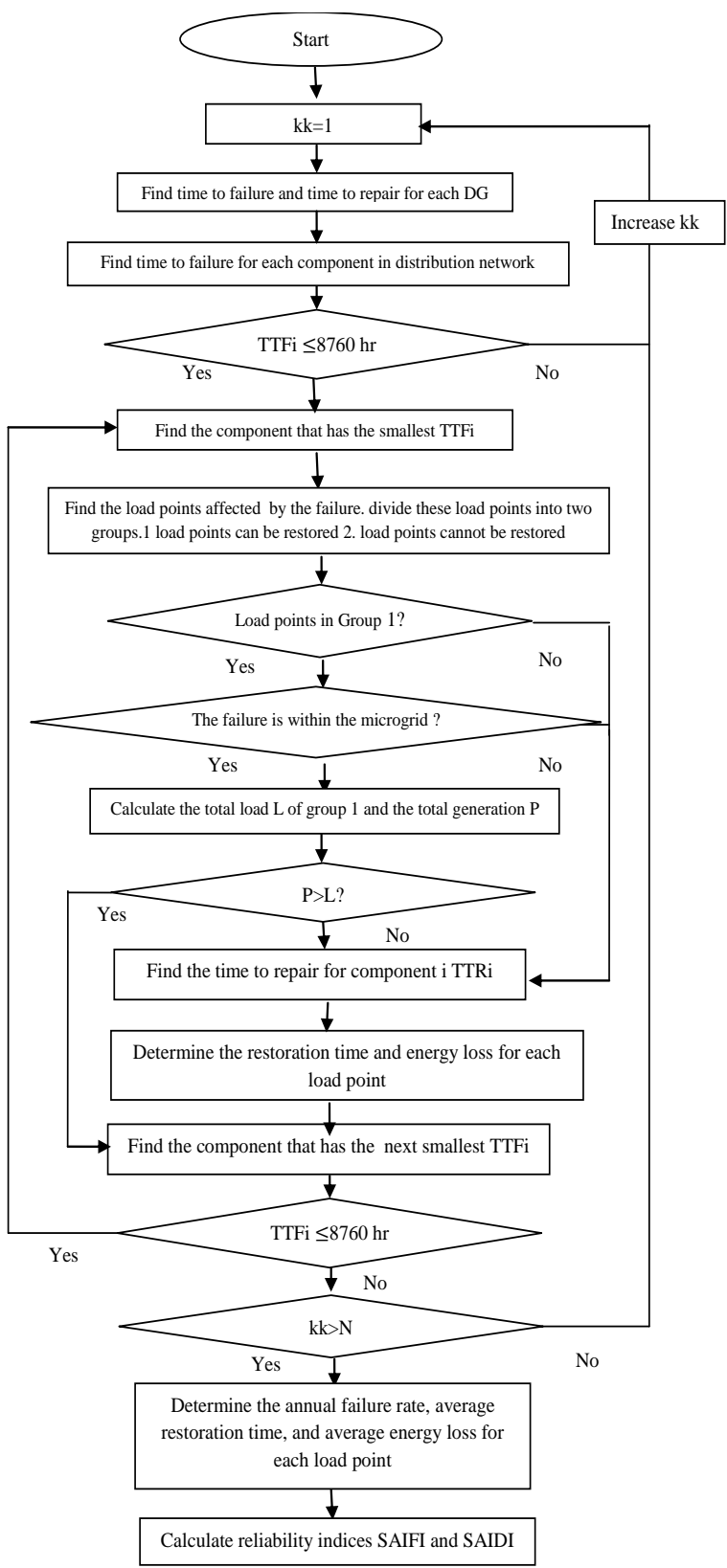

Figure 6.2 Flowchart of Distribution System Reliability Evaluation with Microgrids

### 7. CASE STUDY

Many distribution network reliability studies reported in the literature have used the RBTS Bus 2 or Bus 4. These networks offer the information needed to conduct a reliability study. The system of RBTS Bus 2 is shown in Figure 7.1. The failure rate of the feeders and laterals is a function of their length. The lengths of 11kV feeders and laterals are shown in Table 7.1 The load points data are shown in Table 7.2. The reliability indices of the distribution components are shown in Table 7.3.

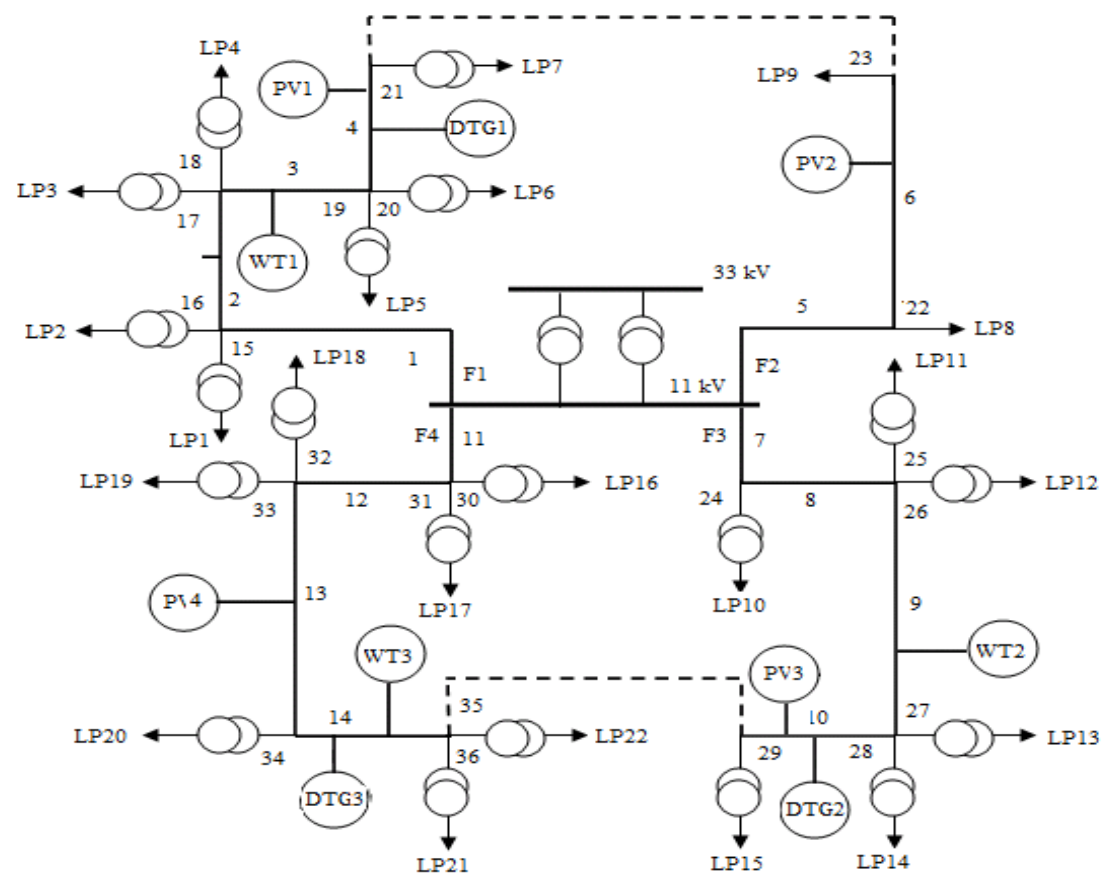

Figure 7.1 Distribution System for RBTS Bus 2 Containing Microgrids

Table 7.1 Feeder Lengths [14]

| Length km | Feeder Section Numbers                            |
|-----------|---|
| 0.6       | 4, 6, 9, 14, 15, 18, 24, 29, 31, 32               |
| 0.75      | 1, 2, 3, 5, 7, 10, 12, 13, 20, 25, 27, 30, 35     |
| 0.80      | 8, 11, 16, 17, 19, 21, 22, 23, 26, 28, 33, 34, 36 |

Table 7.2 Load Points Data [14]

| Load Points     | $P_{peak}$ (MW) | No. of customers per Load Point |
|-----------------|-----------------|---------------------------------|
| 1, 2, 3 10 11   | 0.8668          | 210                             |
| 4 5 13 14 20 21 | 0.5660          | 1                               |
| 6 7 15 16 22    | 0.4540          | 10                              |
| 8               | 1.0000          | 1                               |
| 9               | 1.1500          | 1                               |
| 12 17 18 19     | 0.4500          | 200                             |

Table 7.3 Reliability Indices of Distribution Elements [14]

| Element                    | Failure Rate<br>$\lambda$ | Repair Time<br>$r$ |
|----------------------------|---------------------------|--------------------|
| Transformers (11/0.415 kV) | 0.015 (f/yr)              | 10 hr              |
| Lines (11kV)               | 0.0650(f/yr*km)           | 5 hr               |



The maximum output power of each PV plant is 1.5 MW. The failure rate and average repair time of PV generators are taken to be 0.1 f/yr and 20 h, respectively [11]. The capacity of the storage system is 0.7 MWh and the converter is rated at 0.3 MW. The maximum output power of each WT is 2 MW. The failure rate and average repair time of WT's are 0.25 f/yr and 20 h, respectively [11]. The rated power of each gas generators is 2 MW. The failure rates and average repair time of the DGTs are 0.25 f/yr and 8 h respectively [11]. The solar insolation data is given in Table 7.4. The wind velocity and wind turbine data are given in Table 7.5 The PV efficiency ( $\eta$ ) and  $K_c$  are 0.1 and 0.2  $m/W^2$ .

Table 7.4 The Monthly Light Intensity (kW.hr/day/m<sup>2</sup>)

| Jan  | Feb  | Mar  | Apr   | May   | Jun   | Jul   | Aug   | Sep  | Oct  | Nov  | Dec  |
|------|------|------|-------|-------|-------|-------|-------|------|------|------|------|
| 5.92 | 7.16 | 8.78 | 10.23 | 11.11 | 11.42 | 11.23 | 10.50 | 9.22 | 7.59 | 6.17 | 5.52 |

Table 7.5 The Wind Velocity and Wind Turbine Data (m/s) [26]

| Wind Velocity ( $v_{avg}$ ) | Standard Deviation ( $\sigma$ ) | Cut-in Velocity ( $v_{ci}$ ) | Rated Velocity ( $V_r$ ) | Cut-off Velocity ( $v_{co}$ ) |
|-----------------------------|---------------------------------|------------------------------|--------------------------|-------------------------------|
| 4.05                        | 2.7                             | 2.5                          | 10.55                    | 22.22                         |

The modified RBTS Bus 2 has four microgrids. Microgrid 1 contains feeder 1 and is supplied by PV1, WT1, and DGT1. Microgrid 2 contains feeder 2 and is supplied by PV2. Microgrid 3 contains feeder 3 and is supplied by PV3, WT2, and DGT2. Microgrid 4 contains feeder 4 and is supplied by PV4, WT3, and DGT3. If there is enough power generation to supply the feeder loads during a permanent fault, the microgrids can operate in islanded mode.

In this work, MCS is used to evaluate the reliability of RBTS Bus 2 with and without microgrids. In addition, the impact of implementing storage systems in the reliability assessment of the distribution network is investigated. Figures 7.2, 7.3, and 7.4 show annual average rate, average interruption time, and annual interruption energy of load points in the three cases respectively. Table 7.6 shows the results of the overall reliability indices of the entire system for the three cases. The failure rate of the feeder

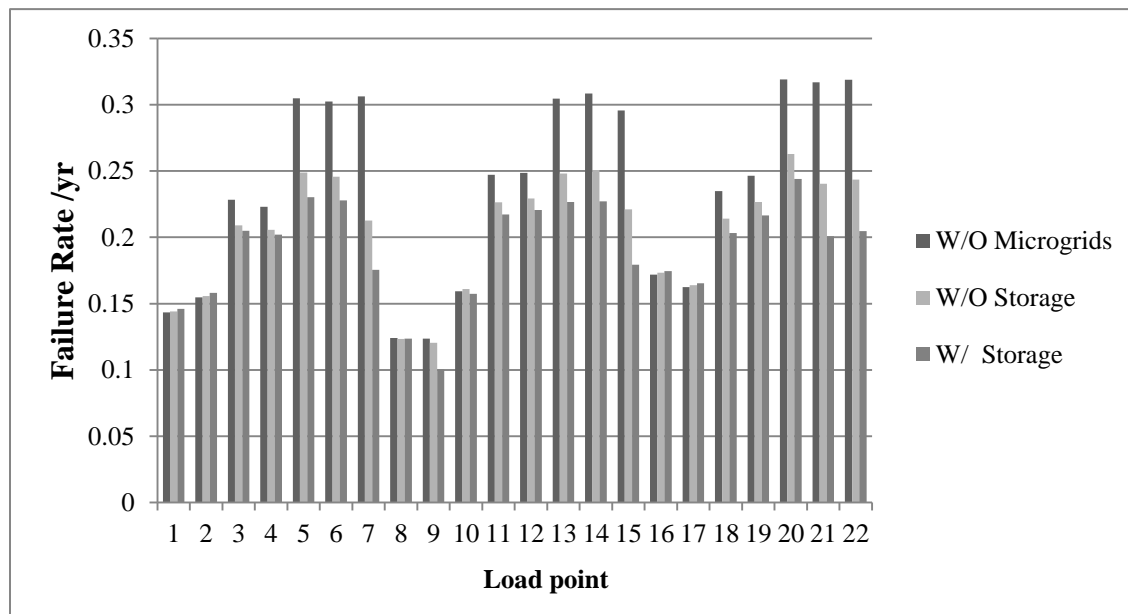

Figure 7.2 Failure Rate of All Load Points

section is a function of the length, and each section has a different length. Therefore, the failure rates of the short feeder (F2) are low compared to the long feeders (F1, F3, F3). In RBTS Bus 2 without microgrids, it is obvious that the load points located at the end of the main feeder have high failure rates because permanent faults result in isolating these load points from the main source. On the other hand, load points located at the end of the main feeder within the microgrid have low failure rates. This reduction in failure rate in a microgrid is due to the excess generation capacity provided by the DGs and storage during the outage of the main sources. In systems with bidirectional power flows, two breakers must be coordinated to isolate the fault from both sides. Therefore, load points connected to the first section of the feeders are considered technically outside the boundary of the microgrids, Figure 7.2 demonstrates that there is no reduction in the average failure rate for these load points. Since a probabilistic simulation was used in this study, it is obvious there is no improvement in the failure rates of load points 1, 2, 8, 15, 16 and 17.

Average interruption time is a function of failure rates and average restoration time of network components. Therefore, all of the previous observations are applicable to Figure 7.3. All of the feeders in RBTS Bus 2 are connected to neighboring feeders through a normal operating point (meaning that the breakers are open in normal condition), which allows network operators to transfer the load in case of a failure on the main feeder. Transferring loads during the failure would result in less average interruption time. The average interruption time of load points located outside the boundary of the microgrid would not be affected by the DGs. In addition, the average

interruption time of the load points connected to the first section of the microgrid pointes are supplied by the main

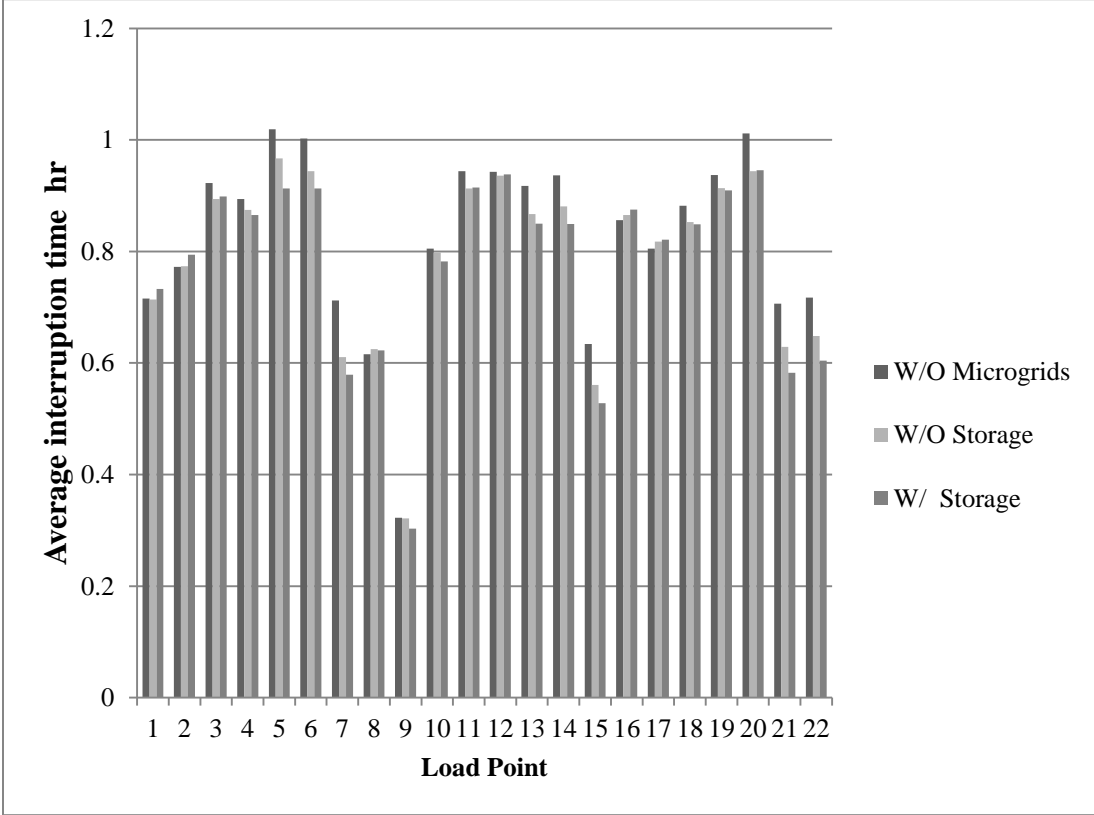

Figure 7.3 Average Interruption Time of All Load Points

grid (two breakers would open to interrupt the fault) or these load points cannot be restored when the first section failed. It is observed that the average interruption time of load points connected to the second feeder section such as 3 and 4 are not accurate in microgrid and storage cases due to using a probabilistic method to evaluate the reliability in this study. As result of this, it is observed from Figure 7.3 that microgrids can reduce average interruption time slightly. The average interruption energy of load point is a

function of the average interruption time and the load of each load point. Therefore all of the previous observations are applicable to Figure 7.4.

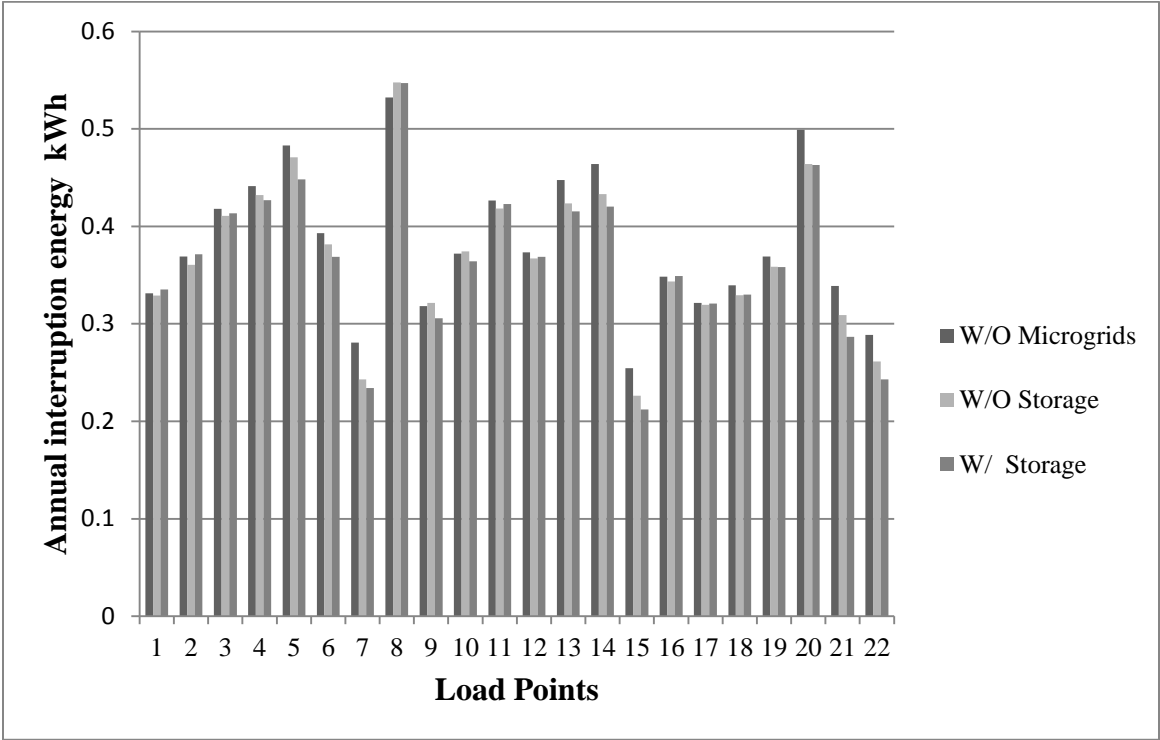

Figure 7.4 Average Interruption Energy of All Load Points

Table 7.6 Reliability Indices of RBTS BUS2

| Index         | Case 1<br>(without microgrid) | Case 2<br>(with microgrid) | Case 3<br>(with storage) |
|---------------|-------------------------------|----------------------------|--------------------------|
| SAIFI (/yr)   | 0.2094                        | 0.1934                     | 0.1875                   |
| SAIDI (hr/yr) | 0.8631                        | 0.8512                     | 0.8449                   |
| EENS (MWh/yr) | 8.3998                        | 8.1945                     | 7.9987                   |

From the previous results, the implementation of DG's in distribution networks can improve the reliability of distribution networks by offering a back up source when the main source is not available. It is observed that the overall reliability indices have improved, which is shown in Table 7.6. Based on the observation in Figures 7.2, 7.3, and 7.4 we observe that reliability improvement associated in the presence of microgrids not only depends on the size of the DGs but also on location and distribution of DGs. These results take into account random events and factors such as failures, variation in WT and PV output power, and the repair time.

## 8. CONCLUSION

The implementation of renewable resources in distribution networks is promising in many aspects such as reducing green gas emissions, improving reliability of power services and reducing the power losses on transmission networks. To accommodate these resources in the distribution network, new technologies must be adopted to deal with the complexity and intermittency of the renewable resources. Microgrids could pave the way to integrate solar energy and wind energy in distribution systems, which can deal with different modes of operation such as islanded mode and interconnected mode.

In this study, a reliability evaluation was conducted on a test distribution network. RBTS Bus2 data have been used because it offers very detailed information on each distribution component such as the failure rate and average restoration time of its circuits, transformers and breakers. Since the original RBTS Bus2 does not contain any distributed generation, the system has been modified to include PV's, WT's, and DGT's.

In order to evaluate the reliability of distribution networks containing PV and WT which are random in their output production, probabilistic techniques must be used for this task. Monte Carlo Simulation is a very useful tool for this purpose; it requires only basic information to generate the artificial history of the system components. By generating large and random numbers of scenarios of the system element, the failure rates and average restoration times can be easily found by calculating the frequency and the duration of the down time of each load point.

A PV stochastic model using normal distribution has been developed to simulate the intermittency of the solar insolation. A two parameters Weibull distribution has been proposed to be used with WT output power model to simulate the randomness of the

wind velocity. A DGT model has been developed to supply the loads during the peak. Failures rates and average restoration times were assigned to all distributed energy resources, and these indices were taken into account in reliability assessment studies.

Common indices such as SAIFI, SAIDI and EENS have been calculated to evaluate the reliability of the distribution network in three cases without microgrids, with microgrids and with storage system. The impact of the DGs in case of the islanded mode has been investigated. Simulation studies have shown that the implementation of DGs in the distribution system can improve the reliability. In the microgrid case, SAIFI, SAIDI, and EENS were improved by 7.64%, 1.4%, and 2.4%, respectively. In storage case, SAIFI, SAIDI, and EENS were improved by 10.60%, 2.12%, and 4.76%, respectively.



## 9. FUTURE WORK

In this work, reliability evaluation of a distribution system containing microgrids using MCS is conducted. Since severe weather conditions can result in forced outages in distribution networks, future work should take into consideration these conditions and come up with a probabilistic model to simulate it to investigate the impact on the reliability. Meteorological data such as the annual rate of the thunder storms and hurricanes at the desired locations should be used.

Since the location and the size of the DG's can affect the reliability of the power systems, finding the optimal size and location of the DG's that will have the greatest reliability improvement can be investigated in future work. Common optimization techniques that consider some constraints such as the range of DG size and the boundary of the DG location in the distribution network can be used for this purpose. For example, Particle Swarms Optimization (PSO) would be a useful and a simple method because it does not use the gradient information.

**APPENDIX A.**

**WIND TURBINE OUTPUT POWER MODEL**

```

function [P3]=WT_output_power(WTno,HourTTF);
%Topic: Stochastic model for wind turbine using Weibull distribution
% Author: Abdulaziz Alkuhayli
% Date: July/2012
Vavg=14.6*(1000/3600); % average wind speed velocity m/s
sta=9.75*(1000/3600); % standard deviation of wind
Vci=9*(1000/3600); % the cut-in velocity m/s
Vr=38*(1000/3600); % the rated wind velocity m/s
Vco=80*(1000/3600); % the rated cut-off velocity m/s
P=[2500;2000]; % the max output power of WT1 and WT2 (KW)
k=2; % shape parameter
c=8.03; % scaling parameter
% finding the output power of wind turbine for 24 hr
for i=1:24;
    F(i)=c*(-log(rand(1)))^(1/k); % generate uniformly distributed random wind velocity
    if F(i)<=Vci || F(i)>=Vco % || means or
        P2(i)=0;
    end
    if F(i)>Vci && F(i)<Vr
        P2(i)=P(WTno)*(F(i)^3-Vci^3)/(Vr^3-Vci^3); % the output power of WT
    end
    if F(i)>Vr
        P2(i)=P(WTno); %the output power of WT
    end
    V(i)=i;
end

P3=P2(HourTTF); % the output power at the desired hour

```

**APPENDIX B.**

**PHOTOVOLTAIC OUTPUT POWER MODEL**

```

function [P2]=PV_output_power(MonthTTF,HourTTF,PVno);

Kc=200; % Threshold 200 M/W^2

nc=0.1; % Solar panel efficiency

S=[1;1.5]; % The max power of PV

% Largest Daylight intensity in every month (Jan-Dec)(unit is kW/m^2)

LDI=[5.92;

    7.16;

    8.78;

    10.23;

    11.11;

    11.42;

    11.23;

    10.50;

    9.22;

    7.59;

    6.17;

    5.52];

for t=1:1:24;

    % from 1Am to 5Am fundamental intensity =0;

    if t <= 5

        I(t)=0;

    end

    f(t)=normpdf(rand(1),0,1); % generate the random number using normal distribution

```

```

if t<= 5;

    I(t)=0;

    P(t)=0;      % output power

    P1(t)=0;

    % from 18 to 24 fundamental intensity =0;

elseif t>=18

    I(t)=0;

    P1(t)=0;

else I(t)=LDI(MonthTTF)/24*(-1/36*t^2+2/3*t-3); % fundamental intensity

    P1(t)=nc*S(PVno)*(I(t)+f(t)*LDI(MonthTTF)/24); % output of power PV

end

V(t)=t;

end

P1(3)=400+P1(3);

for i=4:19

    P1(i)=400+P1(i); % adding storage capacity

end

P1(20)=400+P1(20);

P2=P1(HourTTF); % the output power of the desired hour.

```

**APPENDIX C.**

**GAS TURBINE OUTPUT POWER MODEL**

```
function [P4]=DG_output_power(HourTTF);
```

```
P=zeros(24);
```

```
P(16:20)=2;
```

```
P4=P(HourTTF);
```



**APPENDIX D.**

**RELIABILITY EVALUATION OF RBTS 2**

% Feeder Section Reliability Indices=[feeder section section length km  
% feeder no]

FSRI=[1 0.6 1;2 0.75 1;3 0.8 1;4 0.75 1;5 0.75 2;  
6 0.6 2;7 0.75 3;8 0.8 3;9 0.6 3;10 0.75 3;  
11 0.8 4;12 0.75 4;13 0.75 4;14 0.6 4];

% Lateral Reliability Indices=[Lateral no. Lateral Length Load point Index]

LRI=[15 0.6 1;16 0.8 2;17 0.8 3;18 0.75 4;19 0.8 5;20 0.75 6;21 0.8 7;  
22 0.8 8;23 0.8 9;24 0.6 10;25 0.75 11;26 0.8 12;27 0.75 13;  
28 0.8 14;29 0.6 15;30 0.75 16;31 0.6 17;32 0.6 18;33 0.8 19;  
34 0.8 20;35 0.75 21;36 0.8 22];

% Transformers Location [Trans no, Section Connected to Trans]

TL=[1 1;2 2;3 3; 4 4;5 5;6 6;7 7;8 10;9 11;10 12;11 13;12 14;13 15;14 16;  
15 17;16 18;17 19;18 20;19 21;20 22];

% DG Data =[no of DG,no of section,no of feeder,Type of DG]

% Type of DG : 1 for PV, 2 for WT 3 for Gas Turbine.

DGData=[ 1 4 1 1 0;2 3 1 2 0;3 4 1 3 0;4 6 2 1 0;  
5 10 3 1 0;6 9 3 2 0;7 10 3 3 0;8 14 4 1 0;9 13 4 2 0;10 14 4 3 0 ];

Mu1=1/30; % Photovoltaic Repair Rate(1/h)

Mu2=1/20; % Wind Turbine Repair Rate(1/h)

Mu3=1/8; % Gas Turbine Repair Rate(1/h)

Lamda1=0.1; % Photovoltaic Failure Rate(f/yr)

Lamda2=0.25; % Wind Turbine Failure Rate(f/yr)

Lamda3=0.25; % Gas Turbine Failure Rate(f/yr)

RR=[Mu1 Mu2 Mu3 Mu1 Mu1 Mu2 Mu3 Mu1 Mu2 Mu3]; % Repair Rate of DGs

FR=[Lamda1 Lamda2 Lamda3 Lamda1 Lamda1 Lamda2 Lamda3 Lamda1 Lamda2  
Lamda3 ]; % Failure Rate of DGs

% Load point location and Data=[LP no,From Section,To Section,Feeder no,

% Average load MW, Peak load MW,no of customers]

LP=[1 1 2 1 0.535 0.8668 210;2 1 2 1 0.535 0.8668 210;  
 3 2 3 1 0.535 0.8668 210;4 2 3 1 0.566 0.9167 1;  
 5 3 4 1 0.566 0.9167 1;6 3 4 1 0.454 0.75 10;  
 7 4 4 1 0.454 0.75 10;8 5 6 2 1 1.6279 1;  
 9 6 6 2 1.15 1.8721 1;10 7 8 3 0.535 0.8668 210;11 8 9 3 0.535 0.8668 210;  
 12 8 9 3 0.45 0.7291 200;13 9 10 3 0.566 0.9167 1;  
 14 9 10 3 0.566 0.9167 1;15 10 10 3 0.454 0.75 10;  
 16 11 12 4 0.454 0.75 10;  
 17 11 12 4 0.45 0.7291 200;18 12 13 4 0.45 0.7291 200;  
 19 12 13 4 0.45 0.7291 200;20 13 14 4 0.566 0.9167 1;21 14 14 4 0.566 0.9167 1;  
 22 14 14 4 0.454 0.75 10];

% Distribution Component failure rate (f/yr.km)

Lamda=0.1;

LamdaL=0.065;

% Distribution Component repair time (hr) ( takes to repair)

r=5;

% Switching Time (hr) ( takes to transfer the load to nearby feeder)

s=1;

% Hourly Load Profile [the hourly load factor]

Ph=[0.692280404

0.652746126

0.621201274

0.584524386

0.597240307

0.607917529

0.62269702

0.641021719

0.693909975

0.749798172

0.86213314

0.913332912

0.953107585  
 0.939178521  
 0.948905632  
 0.975809356  
 0.989263363  
 1  
 0.99208044  
 0.955367326  
 0.910367991  
 0.864723072  
 0.815388194  
 0.740724209];

**% Monthly Load Profile [the monthly load factor January - December]**

Pm=[0.598937583  
 0.497343958  
 0.435590969  
 0.434262948  
 0.512616202  
 0.752988048  
 0.942231076  
 1  
 0.969455511  
 0.80810093  
 0.530544489  
 0.486055777];

NC=10000; **% no of trials**

**% initialize failure rate matrix of load points**

Fau=zeros(NC,22);

**% initialize restoration time matrix of load points**

Rest=zeros(NC,22);

**% initialize energy loss matrix of load points**

```

LoEng=zeros(NC,22);
for kk=1:NC;
    % generate the history of the Transformers
    for i=1:length(TL);
        u=rand(1);    % generate a random number
    if u==1;
        u=0.999;
    end
        TTFL(i,1)=(-1/0.05)*log(u)*8760; % finding Time to failure(hr) for each dis
components
        TTFL(i,2)=TL(i,2);    % finding the connected section to transformer
    end
    MinTTFL=min(TTFL(:,1));    % find the transformer that has the least time to
failure.

while(MinTTFL<8760)    % simulation time is year (check it)

    for i=1:length(TTFL(:,1))
        if TTFL(i,1)==MinTTFL
            break
        end
    end
    v=TTFL(i,2);    % v is the index of the least TTF

    MonthTTF=MinTTFL/730;    % convert time to failure from hour to month
    DayTTF=(MonthTTF-floor(MonthTTF))*30; % convert time to failure from month to
day

    if MonthTTF<1;    % convert time to failure from day to hour

```

```

MonthTTF=1;
end
MonthTTF=floor(MonthTTF);
HourTTF=(DayTTF-floor(DayTTF))*24;
if HourTTF<1
    HourTTF=1;
end
HourTTF=round(HourTTF);
TTR=-5*log(rand(1));           % finding time to repair for comp. has least TTF
TTR1=round(TTR);              % round the number to nearest integer
ct1=0;
ct2=0;
for ii=1:TTR1;
    if HourTTF+ct2>=24;
        HourTTF=1;
        ct2=0;
    end
    ct1=ct1+LP(v,6)*Pm(MonthTTF)*Ph(HourTTF+ct2); % finding load of the
desired time.
    ct2=ct2+1;
end
LoEng(kk,v)=ct1+LoEng(kk,v); % Energy loss LP
Fau(kk,v)=1+Fau(kk,v); % failure rate for LP
Rest(kk,v)=TTR+Rest(kk,v); % Restoration time for LP
TTFL(i,:)=[];
MinTTFL=min(TTFL(:,1)); % finding the next comp that has the least TTF
end
% -----

% generate the history of the laterals
for i=1:length(LRI);

```

```

    u=rand(1);
if u==1;
    u=0.999;
end
    TTFL(i,1)=(-1/(LamdaL*LRI(i,2))*log(u)*8760); % finding Time to failure(hr) for
lateral
    TTFL(i,2)=i; % finding the connected section to lateral
    end
MinTTFL=min(TTFL(:,1)); % find the transformer that has the least time to
failure.
while(MinTTFL<8760) % check if the TTF is less than 8760 hr
    for i=1:length(TTFL(:,1));
        if TTFL(i,1)==MinTTFL;
            break
        end
    end
end
    v=TTFL(i,2);
% finding failure time to calculate the energy loss
    MonthTTF=MinTTFL/730; % convert time to failure from hour to month
    DayTTF=(MonthTTF-floor(MonthTTF))*30; % convert time to failure from month to
day
if MonthTTF<1 % convert time to failure from day to hour
    MonthTTF=1;
    end
    MonthTTF=floor(MonthTTF);
    HourTTF=(DayTTF-floor(DayTTF))*24;
if HourTTF<1
    HourTTF=1;
end
    HourTTF=round(HourTTF);
    TTR=-r*log(rand(1));

```

```

TTR1=round(TTR);
ct1=0;
ct2=0;
for ii=1:TTR1;
    if HourTTF+ct2>=24;
        HourTTF=1;
        ct2=0;
    end
    ct1=ct1+LP(v,6)*Pm(MonthTTF)*Ph(HourTTF+ct2);    % finding load of the
desired time.
    ct2=ct2+1;
end
LoEng(kk,v)=ct1+LoEng(kk,v); % Energy loss for LP
Fau(kk,v)=1+Fau(kk,v); % failure rate for LP
Rest(kk,v)=TTR+Rest(kk,v); %Restoration time for LP
TTFL(i,:)=[];
MinTTFL=min(TTFL(:,1));    % finding the next comp that has the least TTF
end
% -----
% generate the DGs history
T=zeros(1,length(RR));
TTFG=zeros(1,length(RR));
TTRG=zeros(1,length(RR));
for ii=1:2
for jj=1:length(RR)
    TTFG1(ii,jj)=-1/FR(jj)*log(rand(1))*8760; % finding Time to failure(hr) for each DG
    TTRG1(ii,jj)=-1/RR(jj)*log(rand(1));    % finding Time to repair (hr) for each DG
    T(1,jj)=[T(1,jj)+TTFG1(ii,jj)+TTRG1(ii,jj)];
end
if min(T)>8760;
    break

```



```

end
end
TTFG1=round(TTFG1);           % round TTF to the nearest integer number.
TTRG1=round(TTRG1);          % round TTR to the nearest integer number.
TTFG=TTFG1(1,:);
for ii=1:length(RR)
    TTRG(1,ii)=TTFG(1,ii)+TTRG1(1,ii);
end
if length(TTFG1(:,1))>1
for ii=1:length(RR)
    TTFG(2,ii)=TTRG(1,ii)+TTFG1(2,ii);
end
for ii=1:length(RR)
    TTRG(2,ii)=TTFG(2,ii)+TTRG1(2,ii);
end
endfor i=1:length(FSRI);      % generate the history of Dist. Comp.
    u=rand(1);
if u==1;
    u=0.999;
end
    TTF(i,1)=(-1/(Lamda*FSRI(i,2))*log(u)*8760); % finding Time to failure(hr) of
each dis components hr
    TTF(i,2)=i;
end
MinTTF=min(TTF(:,1));
while(MinTTF<8760)
    % finding min of TTF
for m=1:length(TTF(:,1)) % finding the Dis component that has least TTF
    if TTF(m,1)==MinTTF;
        break
    end
end

```

```

end
i=TTF(m,2);
Fno=FSRI(i,3); % finding the failed feeder
for k=1:length(FSRI) % finding the first section of the feeder Fno
    if FSRI(k,3)==Fno;
        break
    end
end
ct=0;
for j=1:length(FSRI); % finding the No of sections of feeder Fno
    if FSRI(j,3)==Fno;
        ct=1+ct;
    end
end
LFS=ct+k-1; % finding the last section of feeder Fno
ELD=[];
for j=1:length(LP); % finding the affected load points by the failure that cannot be
restored
    if LP(j,2)==i && LP(j,3)==i+1;
        ELD=[LP(j,1);ELD];
    end
end
ELD1=[];
for j=1:length(LP) % finding the load points affected by the failure that can be restored
    if i==LFS
        ELD1=[];
        break
    end
    if LP(j,1)>max(ELD) && LP(j,4)==Fno;
        ELD1=[LP(j,1);ELD1];
    end
end

```

```

end
% finding failure time to calculate the energy loss
MonthTTF=MinTTF/730;           % convert time to failure from hour to
month
DayTTF=(MonthTTF-floor(MonthTTF))*30;   % convert time to failure from
month to day
if MonthTTF<1                   % convert time to failure from day to hour
    MonthTTF=1;
end
MonthTTF=floor(MonthTTF);
HourTTF=(DayTTF-floor(DayTTF))*24;
if HourTTF<1
    HourTTF=1;
end
HourTTF=round(HourTTF);
% finding the output power of PV1
PVno=1;    % PV no.
[P2]=PV_output_power1(MonthTTF,HourTTF,PVno);
PG(1)=P2/1000;    % to convert it to MW
if i==DGData(1,2);    % if the PV is connected to the failed section
    PG(1)=0;    % the output power equal zero
end
% finding the output power of WT1
WTno=1;    % WT no.
[P3]=WT_output_power(WTno,HourTTF); % if the WT is connected to the failed
section
PG(2)=P3/1000;    % to convert it to MW
if i==DGData(2,2);    % if the WT is connected to the failed section
    % the output power equal zero
    PG(2)=0;
end
end

```

```

% finding the output power of Gas Turbine 1
[PG(3)]=DG_output_power(HourTTF);
if i==DGData(3,2);      % if the DG is connected to the failed section
    PG(3)=0;           % the output power equal zero
end

% finding the output power of PV 2
PVno=1;    % PV no.
[P2]=PV_output_power1(MonthTTF,HourTTF,PVno);
PG(4)=P2/1000;    % to convert it to MW
if i==DGData(4,2);    % if the PV is connected to the failed section
    PG(4)=0;        % the output power equal zero
end

% finding the output power of PV3
PVno=1;
[P2]=PV_output_power1(MonthTTF,HourTTF,PVno);
PG(5)=P2/1000;    % to convert it to MW
if i==DGData(4,2);    % if the PV is connected to the failed section
    PG(5)=0;        % the output power equal zero
end

% finding the output power of WT2
WTno=2;
[P3]=WT_output_power(WTno,HourTTF);
PG(6)=P3/1000;    % to convert it to MW
if i==DGData(5,2);    % if the WT is connected to the failed section
    PG(6)=0;        % the output power equal zero
end

% finding the output power of Gas Turbine 2
[PG(7)]=DG_output_power(HourTTF);
if i==DGData(6,2);    % if the PV is connected to the failed section
    PG(7)=0;        % the output power equal zero

```

```

end

% finding the output power of PV4
PVno=1;
[P2]=PV_output_power1(MonthTTF,HourTTF,PVno);
PG(8)=P2/1000;          % to convert it to MW
if i==DGData(4,2);     % if the PV is connected to the failed section
    PG(8)=0;           % the output power equal zero
end

% finding the output power of WT3
WTno=2;
[P3]=WT_output_power(WTno,HourTTF);
PG(9)=P3/1000;        % to convert it to MW
if i==DGData(5,2);    % if the WT is connected to the failed section
    PG(9)=0;          % the output power equal zero
end

% finding the output power of Gas Turbine 3
[PG(10)]=DG_output_power(HourTTF);
if i==DGData(6,2);    % if the PV is connected to the failed section
    PG(10)=0;         % the output power equal zero
end

for ii=1:length(TTFG(1,:));
    for jj=1:length(TTFG(:,1));
        if (MinTTF>=TTFG(jj,ii) && MinTTF<=TTRG(jj,ii))
            PG(ii)=0;
        end
    end
end

TTR=-r*log(rand(1)); % finding the time to repair
TTR1=round(TTR); % round TTR
for jj=1:length(ELD) % finding the energy loss of ELD

```

```

ct1=0;
ct2=0;
for ii=1:TTR1
    if HourTTF+ct2>=24
        HourTTF=1;
        ct2=0;
    end
    ct1=ct1+LP(ELD(jj,1),6)*Pm(MonthTTF)*Ph(HourTTF+ct2); % finding the total
load of ELD load point
    ct2=ct2+1;
end
    LoEng(kk,ELD(jj))=ct1+LoEng(kk,ELD(jj)); % Energy loss of ELD
end
for jj=1:length(ELD);
    Fau(kk,ELD(jj))=Fau(kk,ELD(jj))+1; % failure rate of ELD
    Rest(kk,ELD(jj))=TTR+Rest(kk,ELD(jj)); % Restoration time of ELD
end

PG1=[];
% finding if the DGs could supply the load point within microgrid
% during failure
%if Fno==1 || Fno==4; % cause the microgrids are located in these feeders
for jj=1:length(DGData(:,1));
    if DGData(jj,2)>i && DGData(jj,3)==Fno
        PG1=[[PG1];DGData(jj,1) DGData(jj,5)]; % the total generation can supply the
load during a failure.
    end
end
d=isempty(PG1);
if d==0
    TotalLoad=0;

```

```

    % finding the total load within the microgrid
    for ii=1:length(ELD1)
        TotalLoad=Ph(HourTTF)*Pm(MonthTTF)*LP(ELD1(ii),6)+TotalLoad;
    end

    % finding the total generation within the microgrid
    Totalgen=0;
    for ii=1:length(PG1(:,1))
        Totalgen=Totalgen+PG(PG1(ii,1))+PG1(ii,2);
    end

    % if the DGs fail to supply the load,
    if Totalgen<=TotalLoad
        for ii=1:length(ELD1);

            Fau(kk,ELD1(ii))=1+Fau(kk,ELD1(ii)); % failure rate of ELD1
            Rest(kk,ELD1(ii))=1+Rest(kk,ELD1(ii)); %Restoration time of ELD1
            LoEng(kk,ELD1(ii))=1*Ph(HourTTF)*Pm(MonthTTF)*LP(ELD1(ii),6)+LoEng(kk,ELD
            1(ii)); % Energy loss of ELD1
        end
    end

    end

    TTF(m,:)=[];
    MinTTF=min(TTF(:,1));

    end

    end

    % finding the average of restoration time
    for jj=1:length(LP);
        Fu(1,jj)=sum(Fau(:,jj))/NC; % finding the average failure rate of load point
        ELoss(1,jj)=sum(LoEng(:,jj))/sum(Fau(:,jj));% total Energy Loss of load point
        ELoss(1,jj)=ELoss(1,jj)*Fu(1,jj); % annual average Energy Loss of load
    point

```

```

    Rest1(1,jj)=sum(Rest(:,jj))/sum(Fau(:,jj)); % total average restoration time of load
point
    Rest1(1,jj)=Rest1(1,jj)*Fu(1,jj);      % annual average restoration time of load
point
end
ct=0;
ct1=0;
EENS=0;
for jj=1:length(LP);
    ct=ct+LP(jj,7)*Fu(1,jj); % total number of customers interrupted
    ct1=ct1+Rest1(1,jj)*LP(jj,7); % Total customer of interruption durations
    EENS=EENS+ELoss(1,jj); % Total expected energy not served
end
SAIFI=ct/sum(LP(:,7)) % finding SAIFI
SAIDI=ct1/sum(LP(:,7)) % finding SAIDI

```



## BIBLIOGRAPHY

- [1] <http://www1.eere.energy.gov/solar/sunshot/> / Nov 2011.
- [2] <http://cleantechnica.com/2012/05/25/2224-gw-pvsolar-output-germany-new-record> May 2012.
- [3] <http://www.epia.org/publications/epiapublications/globalmarketoutlookforphotovoltaicsuntil2016.html> September 2012.
- [4] <http://www.20percentwind.org> September 2012.
- [5] <http://www.evwind.es> September 2012.
- [6] <http://www.wind-energie.de/en> September 2012
- [7] G. Heydt, "The next generation of power distribution systems," IEEE Transactions on Smart Grid, vol. 1, No. 3, pp. 225-235, December 2010.
- [8] C. Chen, Y. Lee and Y. Chang, "A novel control system for microgrid operation and protection," Annual international conference on Instrumentation, Control, Information Technology and System Integration, Tokyo, Japan, Sep. 13-18,2011, p. 722-726.
- [9] S. Lee, "Probabilistic online risk assessment of non-cascading and cascading transmission outage contingencies," European Transactions on Electrical Power, vol. 18,pp. 835-853, November 2008.
- [10] I. Bae and J. Kim, "Reliability evaluation of customers in a microgrid," IEEE Transactions on Power Systems, Vol. 23, No. 3,pp.1416-1422, August 2008.
- [11] L. Husshi , S. Jian, L. Sige, "Reliability evaluation of distribution system containing microgrid," China International Conference Electricity Distribution (CICED), China, September, 2010,pp. 1-6.
- [12] L. Sige, Z. Xiaoxin, F. Mingtain, and Z. Zhuping, "Probabilistic power flow calculation using Sigma-point transform algorithm," International Conference on Power System Technology, Chongqing, China, October 22-26,2006,pp 1-5.
- [13] Y. Wu and W. Change, "Run-time reduction in Schur complement method based transmission constrained dispatch for Monte Carlo production cost," International Conference on Power System Technology, Kunming, China, October 13-17,2002,pp 204-210.
- [14] R. N. Allan, R. Billinton, I. Sjarief, L. Goel, and K.S. So, "A reliability test system for educational purposes basic distribution system data and results," IEEE Transactions on Power Systems ,Vol. 6, No. 2, pp.813-820, May 1991.

- [15] R. Billinton, S. Kumar, N. Chowdhury, K. Chu, K. Debnath, L. Goel, E. Khan, P. Kos, G. Nourbakhsh and J. Oteng-Adjei, "A reliability test system educational purposes basic data," *IEEE Transaction on Power Systems*, Vol. 4, No. 3, pp. 1238-1244, August 1989.
- [16] A. David, "Availability modeling of stochastic power sources," *IEE Proceeding*, Vol. 129, No. 6, pp.239-248, November 1982.
- [17] M. Khallat and S. Rahman, "A probabilistic approach to photovoltaic generator performance prediction," *IEEE Transactions on Energy Conversion*, Vol. Ec-1, No. 3, pp.34-40, September 1986.
- [18] T. Sitoh, H. Suzuki and Y. Sekine, "Economic evaluation of a residential photovoltaic system based on a probability model using actual metrological data," *IEEE Transaction on Energy Conversion*, Vol. EC-2, No. 1, pp. 9-15, March 1987.
- [19] P. Gioresto and K. Utsugoi, "Development of a new procedure for reliability modeling of wind turbine generators," *IEEE Transactions on Power Apparatus and Systems*, Vol. PAS-102, No.1, pp.134-143, January 1983.
- [20] X. Wang, H. Dai and R. Thomas, "Reliability modeling of large and associated utility interface systems," *IEEE Transactions on Power Apparatus and Systems*, Vol. PAS-103, No. 3, pp. 569-575, March 1984.
- [21] R. Karki, P. Hu and R. Billinton, "A simplified wind power generation model for reliability evaluation," *IEEE Transaction on Energy Conversion*, Vol. 21, No. 2, pp. 533-540, June 2006.
- [22] R. Billinton and P. Wang, "Teaching distribution system reliability evaluation using Monte Carlo simulation," *IEEE Transactions on Power Systems*, Vol. 14, No. 2, pp. 397-403, May 1999.
- [23] S. Lin, M. Han, R. Fan., and X. Hu., "Configuration of energy storage system for distribution network with high penetration of PV," *Renewable Power Generation(RPG 2011) IET Conference*, Edinburgh, UK, September, 2011, pp.1-6.
- [24] J. Li, B. Zhang, J. Wang, C. Mao, Y. Liu, K. Wang, Y. Duan, X. Zheng, and L. Wan, "Steady security risk assessment considering uncertainties of wind power and fault in smart grid," *Modeling, Identification and Control, International Conference*, Okayama, Japan, July, 2010, pp. 600-605.
- [25] Y. Atwa and E. El-Saadany, "Reliability evaluation for distribution system with renewable distributed generation during islanded mode of operation," *IEEE Transactions on Power Systems*, Vol. 24, No. 2, pp.572-581, May 2009.
- [26] X. Liu, A. Chowdhury, and D. Koval, "Reliability evaluation of a wind-diesel-battery hybrid power system," *Industrial and Commercial Power Systems Technical Conference*, Clearwater Beach, Florida, USA, May, 2008, pp. 1-8.

[27] S. Cha, D. Jeon, I. Lee, and J. Kim, "Reliability evaluation of distribution system connected photovoltaic generation considering weather effects," Probabilistic Methods Applied to Power Systems, International Conference, Ames, Iowa, USA, September 2004, pp. 451-456.

[28] <http://www.puc.texas.gov/>

[29] R. Billinton, and R. Allan, Reliability evaluation of power systems, Longmans, London Press, New York (1994).

## VITA

Abdulaziz Alkuhayli was born in 1983, in Baljorashi, Saudi Arabia. He received his Bachelor's degree in Electrical Engineering from King Saud University, Riyadh, Saudi Arabia in June 2006. He joined Saudi Electricity Company in 2006 as an operating engineer at the national control center. In 2009, he joined King Saud University as a teaching assistance where he was granted a scholarship to study Master and PhD abroad. In 2011, he joined Missouri University of Science and Technology (formerly University of Missouri – Rolla) to pursue a Master's degree. In the fall of 2012, he received his master's degree.

