

ANALYSIS OF DIFFERENT STRATEGIES FOR CIRCUIT OPTIMIZATION

Alexander Zemliak

Universidad Autónoma de Puebla

azemliak@fcm.buap.mx

Fernando Reyes Cortés

Universidad Autónoma de Puebla

freyes@ece.buap.mx

Resumen

El proceso de la optimización del circuito analógico es definido matemáticamente como un sistema dinámico controlable. En este contexto, podemos formular el problema de minimizar el tiempo de la CPU como el problema de minimización de un proceso de transición de un sistema dinámico. Para analizar las propiedades de tal sistema, proponemos de usar el concepto de la función de Lyapunov de un sistema dinámico. Esta función permite analizar la estabilidad de las trayectorias de optimización y predecir el tiempo de la CPU para la optimización del circuito analizando las características de la parte inicial del proceso.

Palabras Claves: Diseño del sistema en el tiempo mínimo, estrategia óptima en el tiempo, función de Lyapunov, optimización del circuito, teoría de control.

Abstract

The process of analog circuit optimization is defined mathematically as a controllable dynamical system. In this context, we can formulate the problem of minimizing the CPU time as the minimization problem of a transitional process of a dynamical system. To analyse the properties of such a system, we propose to use the concept of the Lyapunov function of a dynamical system. This function allows us to analyse the stability of the optimization trajectories and to predict the CPU

time for circuit optimization by analysing the characteristics of the initial part of the process.

Keywords: *Circuit optimization, control theory, Lyapunov function, minimal-time system design, time-optimal strategy.*

1. Introduction

The problem of reducing the CPU time taken by electronic circuit optimization is one of the important problems related to improving design quality. The design process starts with an initial approximation done by analysing the circuit for the initial point, and then the system parameters are adjusted to obtain the performance characteristics included in the specification. The process of adjusting parameters can be based on an optimization procedure. Some methods reduce the time need for circuit analysis. This includes the well-known idea of using sparse matrix methods [Bunch, 1976], [Osterby, 1983] and decomposition methods [Rabat et al., 1985]. Some alternative methods such as homotopy methods [Tadeusiewicz, 2013] were successfully applied to circuit analysis.

Practical methods of optimisation were developed for circuit designing, timing, and area optimisation [Brayton et al., 1981]. However, classical deterministic optimisation algorithms may have a number of drawbacks: they may require that a good initial point be selected in the parameter space, and they require that the cost function be continuous and differentiable. To overcome these issues, special methods were applied to determine the initial point of the process by centering [Stehr et al., 2003] or applying geometric programming methods [Hershenson et al., 2001] that guarantee the convergence to a global minimum, but this require a special formulation of design equation to which additional difficulties accompany. Other approach based on the idea of space mapping technique [Koziel et al., 2006].

Some another ways were proposed to reduce the total computer design time [Kashirskiy, 1979], [Rizzoli et al., 1990], [Ochotta et al., 1996].

The more general formulation of the circuit optimization problem is proposed in [Zemliak, 2001]. There, the problem of analogue circuit optimization is defined in

terms of control theory. The potential advantages of new approach have been shown at a formulation of process of designing of electronic circuits in terms of the control theory. We suppose that this approach allows us to considerably accelerate deterministic optimization methods and to compete with stochastic algorithms in terms of CPU time. This approach was successfully developed in work [Zemliak, 2014]. This paper studied some principal characteristics of optimization strategies, which form the complete basis of different designing strategies of new methodology. The possibility was shown to significantly reduction of CPU time on the basis of this approach. In work [Zemliak, 2015] the characteristics of the optimization process for nonlinear circuits were analyzed on the basis of the Lyapunov function definition. This approach promises more precise analysis of optimization strategies with the aim to investigate the stability of various strategies and to improve the selection of the best strategy.

In the presented work we follow further development of this direction with the purpose to reveal the main regularities and properties of the optimal algorithm of designing. These properties will allow constructing the optimal algorithm, which implements the process of designing for minimum possible processor time. This problem is important and rather complex challenge of the control theory as well, because is required to build the algorithm during the "real time", i.e. in the course of optimization of electronic circuit.

The main properties and the special conditions for the optimal design strategy construction are the first problems that need to be solved for the optimal algorithm searching. In this case the analysis of the Lyapunov function properties of the optimization process is a very perspective approach for searching of the best strategies with the minimal processor time.

2. Methods

The In accordance with the conventional approach, the process of electronic circuit optimization is defined as the problem of minimizing an objective function $C(X)$, $X \in R^N$, with constraints given by a system of the circuit's equations based on Kirchhoff's laws. We assume that, by minimizing $C(X)$, we achieve all our

design goals. An approach proposed in [Zemliak, 2001] generalizes the circuit optimization problem by introducing a special control vector $U=(u_1, u_2, \dots, u_M)$ and a special generalized objective function $F(X, U)$.

The design process for any analog system design can be defined in discrete form as the problem of the generalized cost function $F(X, U)$ minimization by means of the system (equation 1) with the constraints (equation 2).

$$x_i^{s+1} = x_i^s + t_s \cdot f_i(X, U), \quad i = 1, 2, \dots, N \quad (1)$$

$$(1 - u_j) \cdot g_j(X) = 0, \quad j = 1, 2, \dots, M \quad (2)$$

where $X \in \mathbb{R}^N$, $X = (X', X'')$, $X' \in \mathbb{R}^K$ is the vector of the independent variables and the vector $X'' \in \mathbb{R}^M$ is the vector of dependent variables ($N=K+M$), $g_j(X)$ for all j presents the network model, s is the iterations number, t_s is the iteration parameter, $t_s \in \mathbb{R}^1$, $H \equiv H(X, U)$ is the direction of the generalized cost function $F(X, U)$ decreasing, U is the vector of the special control functions $U=(u_1, u_2, \dots, u_M)$, where $u_j \in \Omega$; $\Omega = \{0; 1\}$. The functions $f_i(X, U)$ for example for the gradient method are defined in equations 3.

$$f_i(X, U) = -\frac{\delta}{\delta x_i} F(X, U), \quad i = 1, 2, \dots, K \quad (3)$$

$$f_i(X, U) = -u_{i-K} \frac{\delta}{\delta x_i} F(X, U) + \frac{(1 - u_{i-K})}{t_s} \{-x_i^s + \eta_i(X)\}, \quad i = K+1, K+2, \dots, N$$

Where the operator $\frac{\delta}{\delta x_i}$ hear and below means:

$$\frac{\delta}{\delta x_i} \varphi(X) = \frac{\partial \varphi(X)}{\partial x_i} + \sum_{p=K+1}^{K+M} \frac{\partial \varphi(X)}{\partial x_p} \frac{\partial x_p}{\partial x_i}$$

x_i^s is equal $x_i(t-dt)$; $\eta_i(X)$ is the implicit function ($x_i = \eta_i(X)$) that is determined by the system (equation 2). The generalized cost function $F(X, U)$ can be defined for example as equation 4.

$$F(X,U) = C(X) + \psi(X,U) \quad (4)$$

Where $C(X)$ is the nonnegative cost function of the design process, and $\psi(X,U)$ is the additional penalty function, equation 5.

$$\psi(X,U) = \frac{1}{\varepsilon} \sum_{j=1}^M u_j \cdot g_j^2(X) \quad (5)$$

This formulation of the design process permits the redistribution of the computer time expense between the solution of problem (equation 2) and the optimization procedure (equation 1) for the function $F(X,U)$. The control vector U is the main tool for the redistribution process in this case. Practically an infinite number of the different design strategies are produced because the vector U depends on the optimization procedure current step. The problem of the optimal design strategy search is formulated now as the typical problem for the functional minimization of the control theory. The functional that needs to minimize is the total CPU time T of the design process. This functional depends directly on the operations number and on the design strategy that has been realized. The main difficulty of this definition is unknown optimal dependencies of all control functions U_j . It is necessary to find the optimal behavior of the control functions U_j during the design process to minimize the total design computer time.

The idea of the system design problem formulation as the functional minimization problem of the control theory is not depend of the optimization method and can be embedded into any optimization procedures. In this paper the gradient method is used, nevertheless any optimization method can be used as shown in [Zemliak, 2001].

Now the process for analog network design is formulated as a dynamic controllable system. The minimal-time design process can be defined as the dynamic system with the minimal transition time in this case. So, we need to find the special conditions to minimize the transition time for this dynamic system.

Let us define the Lyapunov function of the design process (equations 1-5) by the equation 6.

$$V(X,U) = [F(X,U)]^r \quad (6)$$

Where $F(X,U)$ is the generalized cost function of the design process. So, the function V has properties: $V(a,U)=0$, $V(X,U)>0$ for all X and at last, this function increases in a sufficient large neighborhood of the stationary point. The Lyapunov function can be used for analysis of stability of any strategies of optimization.

According to Lyapunov's method, the information about the stability of a trajectory is contained in the time derivative of the Lyapunov function $\dot{V} = dV/dt$. The optimization process and its corresponding trajectory are steady if this derivative is negative. In this paper, the direct computation of Lyapunov function V is based on the formula (6), where the parameter r is equal to 0.5. This kind of formula improves the separation of curves for different strategies and gives us the possibility to analyse the behaviour of Lyapunov function by the better manner. By conducting a detailed behavioural analysis of the Lyapunov function and its derivative for different optimization strategies, we can choose perspective strategies.

We would like to obtain some quantitative characteristics for the behaviour of the Lyapunov function and its derivative. Earlier defined electronic circuit is optimized in this section on the basis of continuous form of the circuit optimization process (equations 2–5). Our goal is to obtain, for each strategy, an interrelation between its relative CPU time and the behaviour of the derivative of its corresponding Lyapunov function.

We can use now a more informative function, namely the relative time derivative of the Lyapunov function $W = \dot{V}/V$. This allows us to compare different strategies in terms of the behaviour of the function $W(t)$.

In works [Zemliak, 2007], [Zemliak, 2008], some strategies for circuit optimization have been analyzed and Lyapunov function was entered on the basis of the formula other than (equation 6). The behavior of this function was analyzed for the optimization of some simple nonlinear circuits. It is shown that there is a dependency between the time necessary for optimization of a circuit and behavior

of the Lyapunov function. At the same time, in the presented paper the behavior of the normalized functions is investigated during the optimization process: the Lyapunov function computed by the equation 6 and its time derivative. It allowed to study in detail properties of these functions both for simple passive nonlinear circuits and for some transistor amplifiers.

3. Results

In what follows, we give an analysis of the optimization process for some nonlinear circuits.

To present an analysis of the behaviour of functions $V(t)$ and $W(t)$, we use the test examples of passive and active nonlinear circuits, which allows us to explain the principal features of the behaviour of the function $W(t)$. Figure 1 presents a three-node nonlinear passive circuit.

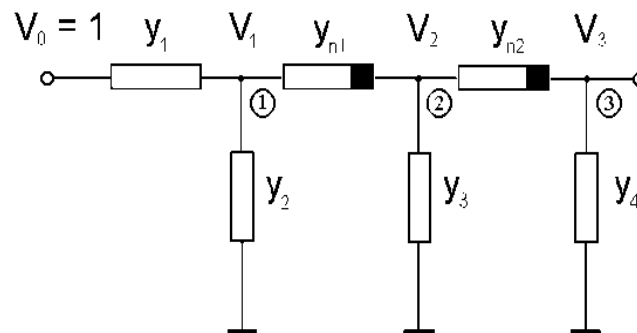

Figure 1 Three-node nonlinear passive circuit.

Here, the circuit model (equation 2) consists of three equations ($M=3$), and the control vector U consists of three components as well: $U = (u_1, u_2, u_3)$. The structural basis consists of eight different optimization strategies. The nonlinear elements are given as follows: $y_{n1} = a_{n1} + b_{n1} \cdot (V_1 - V_2)^2$ and $y_{n2} = a_{n2} + b_{n2} \cdot (V_2 - V_3)^2$. The vector X consists of seven components, set as follows: $x_1^2 = y_1$, $x_2^2 = y_2$, $x_3^2 = y_3$, $x_4^2 = y_4$, $x_5 = V_1$, $x_6 = V_2$ and $x_7 = V_3$. By defining the components x_1, x_2, x_3 . Using the above formulas, we automatically obtain positive values of the conductance, which eliminates the issue of positive definiteness for

each resistance and conductance and allows us to carry out optimization in the full space of the values of these variables without any restrictions. This circuit is a voltage divider, and the objective function can be defined by the formula $C(X) = (V_3 - V_{30})^2$, where V_{30} is the required value of the output voltage V_3 , which must be obtained during the optimization process.

Table 1 presents the analysis of the results of the optimization process for the eight strategies that form the complete structural basis.

Table 1 Complete set of strategies of structural basis for three-node nonlinear circuit.

N	Control vector	Iterations number	Total processor time (sec)
1	(0 0 0)	519963	39.957
2	(0 0 1)	1261184	46.126
3	(0 1 0)	689354	23.276
4	(0 1 1)	230500	4.721
5	(1 0 0)	158245	5.810
6	(1 0 1)	402037	13.844
7	(1 1 0)	212405	6.182
8	(1 1 1)	446205	5.531

For each strategy, we measure the CPU time needed to reach the time point that minimizes the function V . We introduce the functions V and W , which are the normalized versions of the functions $V(t)$ and $W(t)$. This normalization is done as follows: $V = V(t)/V_{max}$ and $W = W(t)/W_{max}$, where V_{max} and W_{max} are the maximum values of the functions $V(t)$ and $W(t)$, respectively, among the entire structural basis. We do similar normalization for all the examples.

Our main objective is to identify the main criterion that would allow us to compare various strategies and to choose the fastest of them during optimization, without computing the CPU time directly.

As we can see from figure 2, the functions V and W give an exhaustive explanation for the characteristics of the optimization process. First of all, we can conclude that the Lyapunov function decreases at a rate that is inversely proportional to the CPU time. The minimum value of the Lyapunov function, which corresponds to the maximum precision, is approximately equal for all the strategies.

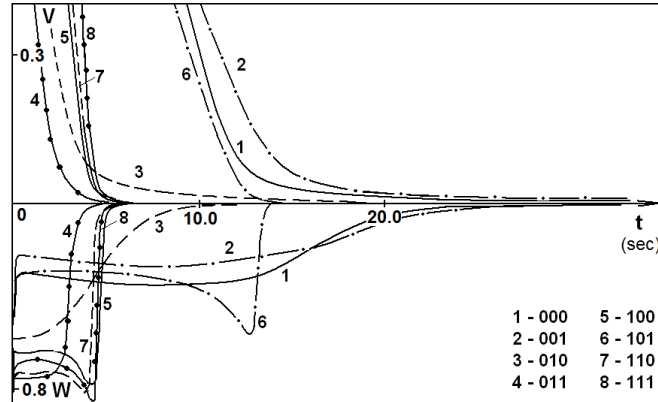

Figure 2 Behaviour of the functions V and W for eight strategies during the optimization process, for three-node nonlinear passive circuit.

We can see that there is a correlation between the total CPU time for a any strategy and the behaviour of the function W that corresponds to this strategy. The larger the absolute value of the function W in the initial part of the optimization process - the faster the Lyapunov function decreases. In this case, the total CPU time is also the shortest.

We can identify three groups of strategies of the structural basis. The first group contains strategies 4, 5, 7 and 8, which have the largest absolute value of the function W during the initial part of the optimization process. At the same time, these strategies have the shortest CPU time. The second group contains strategies 1 and 2, which have the minimum absolute value of the function W. It is these strategies that have the longest CPU time. The third group contains strategies 3 and 6, whose CPU is intermediate. For these strategies, the behaviour of the function W is also intermediate. Therefore, we can state that there is a correlation between the CPU time and the behaviour of the function W.

The next example is devoted to the analysis of optimization process for an amplifier with feedback in figure 3.

The circuit contains six nodes. There are nine independent variables $y_1, y_2, y_3, y_4, y_5, y_6, y_7, y_8, y_9$ ($K=9$) and six dependent variables $V_1, V_2, V_3, V_4, V_5, V_6$ ($M=6$). The vector \mathbf{X} includes 15 components. The objective function of optimization procedure was determined as

$C(X) = (V_1 - V_2 - k_1)^2 + (V_3 - V_2 - k_2)^2 + (V_4 - k_3)^2 + (V_5 - k_4)^2 + (V_5 - V_6 - k_5)^2 + (E_1 - V_6 - k_6)^2$,
 where k_1, k_2, k_3, k_4, k_5 and k_6 are the before-defined values of voltages on GS and DS for Q_1, Q_2 and Q_3 .

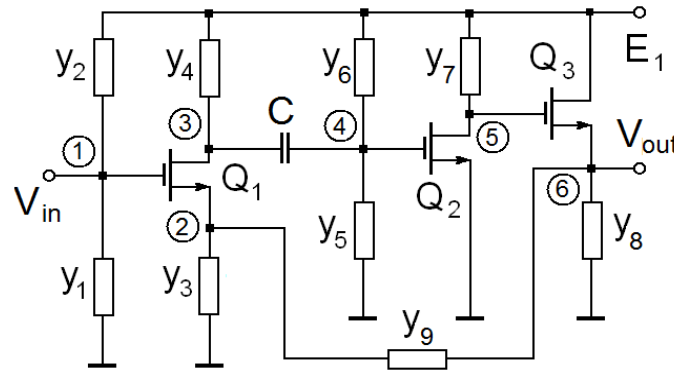

Figure 3 Circuit topology for amplifier with feedback.

These parameters were defined as: $k_1 = -1.8$ V, $k_2 = 6.8$ V, $k_3 = -2.0$ V, $k_4 = 6.8$ V, $k_5 = -1.5$ V, $k_6 = 6.0$ V. The initial and final values of vector \mathbf{X} are equal: $X^0 = (0.02, 0.02, 0.02, 0.05, 0.01, 0.015, 0.01, 0.05, 0.01, 2, 1.5, 3, 2, 3, 2, 1)$ and $X^f = (0.008, 0.004, 0.022, 0.01, 0.009, 0.004, 0.01, 0.022, 0.006, 5.8, 3.8, 10.6, 1.8, 6.6, 5.1)$.

The final values of the admittances are equal to: $y_1 = 0.06658 \cdot 10^{-3}$ ($R_1 = 15.02 \cdot 10^3 \Omega$), $y_2 = 0.02 \cdot 10^{-3}$ ($R_2 = 50 \cdot 10^3 \Omega$), $y_3 = 0.502 \cdot 10^{-3}$ ($R_3 = 1.99 \cdot 10^3 \Omega$), $y_4 = 0.1 \cdot 10^{-3}$ ($R_4 = 10.0 \cdot 10^3 \Omega$), $y_5 = 0.083 \cdot 10^{-3}$ ($R_5 = 12.05 \cdot 10^3 \Omega$), $y_6 = 0.02 \cdot 10^{-3}$ ($R_6 = 50 \cdot 10^3 \Omega$), $y_7 = 0.1 \cdot 10^{-3}$ ($R_7 = 10.0 \cdot 10^3 \Omega$), $y_8 = 0.5012 \cdot 10^{-3}$ ($R_8 = 1.995 \cdot 10^3 \Omega$), $y_9 = 0.031 \cdot 10^{-3}$ ($R_9 = 32.26 \cdot 10^3 \Omega$).

The results of the analysis of COS and some other strategies of the structural basis are given in table 2 and figure 4.

Once again, we can identify three groups of strategies. First group includes strategies 4, 8 and 10 that have the largest absolute value of the function W in the initial part of the optimization process and shorter CPU times. Computer time gain for the strategy 4 in comparison with COS is equal 280. Second group, strategies 3, 5, 6, 7 and 9 have intermediate values of the function W and intermediate CPU times. Finally, the strategies 1 and 2 have small absolute values of the function W and long CPU times.

Table 2 Some strategies of optimization for amplifier with feedback.

N	Control functions vector U(u1,u2,u3,u4,u5,u6)	Iterations number	Total design time (sec)
1	(0 0 0 0 0 0)	24417	117.674
2	(0 0 1 1 1 0)	25546	73.993
3	(0 1 1 0 0 1)	19306	3.181
4	(0 1 1 1 1 1)	561	0.420
5	(1 1 1 0 0 0)	5258	5.732
6	(1 1 1 0 1 0)	4457	4.287
7	(1 1 1 0 1 1)	2359	2.785
8	(1 1 1 1 0 1)	1427	0.813
9	(1 1 1 1 1 0)	2934	1.751
10	(1 1 1 1 1 1)	1923	0.486

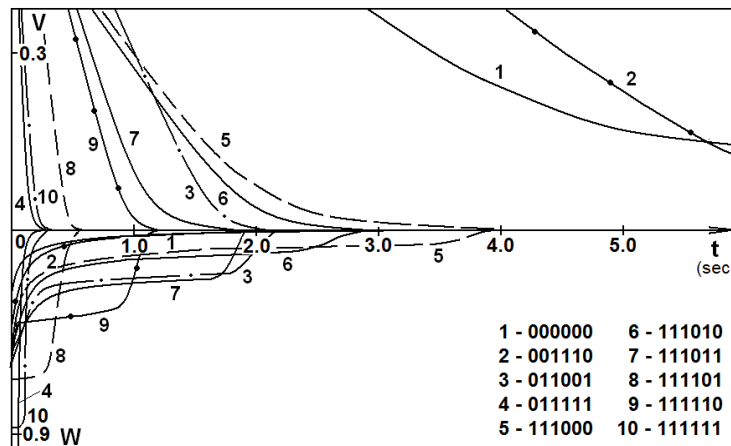

Figure 4 Behaviour of the functions V and W for the eight strategies during the optimization process, for amplifier with feedback.

4. Discussion

Now we have proved the existence of the strong correlation between the CPU time and the properties of the Lyapunov function. Moreover this function also estimates the comparative performance time for each optimization strategy.

Summing up the obtained results, we can conclude that, by analysing the behaviour of the relative time derivative of the Lyapunov function of the optimization process in the initial interval of the optimization process, we can predict the total relative CPU time for a given strategy. It means that, to compare

the total CPU time of optimization for different strategies, we do not have to run the entire optimization process for each strategy. To determine the strategy with the shortest CPU time, it is sufficient to compare the behaviour of the function $W(t)$ in the initial part of the optimization process. We can obtain the time gain from 2 to 3 orders of magnitude for the best strategy in comparison with COS. It is important to emphasize that the obtained ratios and conclusions are a basis for creation further of the optimum algorithm that implement the best strategy of circuit optimization for minimum CPU time. This purpose is the main at creation of the generalized designing methodology. The obtained results are a basis for designing of optimum algorithm because allow to define the best strategy of optimization of a circuit by the analysis of properties of an initial interval of the optimization process. The main difficulty in creation of such algorithm, is its adaptation structure, i.e. the algorithm has to build the optimal designing strategy in the regime of "real time".

5. Conclusions

The generalized approach for circuit optimization gives possibility to considerably reduce the necessary CPU time. Relative gain of the best strategy in comparison with traditional, reaches 2-3 orders of magnitude. Absolute gain can reach several minutes or hours for sufficiently small circuits and it increases at increase in the size and complexity of the circuit.

Based on the analysis presented in this paper, we can conclude that the properties of a given circuit optimization strategy depend on the stability of each strategy that can be defined by means of the Lyapunov function of the optimization process. A special function – the relative time derivative of the Lyapunov function – is a sufficiently informative source when searching for the strategies that minimize the CPU time. We discovered a strong correlation between the properties of the Lyapunov function and its corresponding CPU time. The shortest CPU time is also shown by those strategies that have the largest absolute value of the relative time derivative of the Lyapunov function in the initial part of the optimization trajectory. This property can be the basis for developing an optimal or quasi optimal design algorithm.

6. Bibliography and References

- [1] Brayton, R.K., Hachtel, G.D. & Sangiovanni-Vincentelli, A.L. A survey of optimization techniques for integrated-circuit design. *Proc. IEEE*, V. 69, No. 10, 1334-1362, 1981.
- [2] Bunch, J.R. & Rose, D.J. (Eds), *Sparse Matrix Computations*, New York, Acad. Press, 1976.
- [3] Hershenson, M., Boyd, S. & Lee, T. Optimal design of a CMOS op-amp via geometric programming. *IEEE Trans. CAD Integr. Circ. Sys.* V. 20, No. 1, 1–21, 2001.
- [4] Kashirskiy, I.S. & Trokhimenko, Y.K. *General optimization of electronic circuits*. Kiev, Tekhnika, 1979.
- [5] Koziel, S., Bandler, J.W. & Madsen, K. Space-mapping-based interpolation for engineering optimization. *IEEE Trans. MTT*, V. 54, No. 6, 2410-2421, 2006.
- [6] Ochotta, E.S., Rutenbar, R.A. & Carley, L.R. Synthesis of high-performance analog circuits in ASTRX/OBLX. *IEEE Trans. CAD Integr. Circ. Sys.*, V. 15, 273–294, 1996.
- [7] Rabat, N., Ruehli, A.E., Mahoney, G.W. & Coleman, J.J. A survey of macromodelling. *Proc. of IEEE Int. Sym. CAS*, 139-143, June 1985.
- [8] Rizzoli, V., Costanzo, A. & Cecchetti, C. Numerical optimization of broadband nonlinear microwave circuits. *Proc. IEEE MTT-S Int. Symp.*, 335–338, Dallas, USA, May 1990.
- [9] Stehr, G., Pronath, M., Schenkel, F., Graeb, H. & Antreich, K. Initial sizing of analog integrated circuits by centering within topology-given implicit specifications. *Proc. IEEE/ACM Int. Conf. CAD*, 241–246, 2003.
- [10] Tadeusiewicz, M. & Kuczynski, A. A very fast method for the DC analysis of diode-transistor circuits. *Circ. Sys. Sign. Proces.*, V. 32, No. 3, 433-451, 2013.
- [11] Zemliak, A.M. Analysis of Dynamic Characteristics of a Minimal-Time Circuit Optimization Process, *Int. J. of Mathematic Models and Methods in Applied Sciences*, V. 1, 1-10, 2007.

- [12] Osterby, O. & Zlatev, Z. *Direct Methods for Sparse Matrices*. New York, Springer-Verlag, 1983.
- [13] Zemliak, A.M. Analog System Design Problem Formulation by Optimum Control Theory. *IEICE Trans. Fundam.*, V. E84-A, 2029-2041, 2001.
- [14] Zemliak, A.M. Comparative Analysis of the Lyapunov Function for Different Strategies of Analogue Circuits Design. *Radioelect. and Communic. Sys.*, V. 51, 233-238, 2008.
- [15] Zemliak, A. Analog circuit optimization on basis of control theory approach. *COMPEL: The Int. J. Comp. and Math. in Electrical Electronic Engineering*, V. 33, 2180-2204, 2014.
- [16] Zemliak, A. & Markina, T. Behavior of Lyapunov's function for different strategies of circuit optimization. *Int. J. Electronics*, Vol. 102, No. 4, 619-634, 2015.