

01 Jan 2016

## Pre-College Engineering Activities with Electronic Circuits (Work-in-Progress)

Steve Eugene Watkins

Missouri University of Science and Technology, [watkins@mst.edu](mailto:watkins@mst.edu)

Follow this and additional works at: [https://scholarsmine.mst.edu/ele\\_comeng\\_facwork](https://scholarsmine.mst.edu/ele_comeng_facwork)



Part of the [Electrical and Computer Engineering Commons](#), and the [Engineering Education Commons](#)

---

### Recommended Citation

S. E. Watkins, "Pre-College Engineering Activities with Electronic Circuits (Work-in-Progress)," *Proceedings of the 2016 Annual Conference of the American Society for Engineering Education (2016, New Orleans, LA)*, American Society for Engineering Education (ASEE), Jan 2016.

This Article - Conference proceedings is brought to you for free and open access by Scholars' Mine. It has been accepted for inclusion in Electrical and Computer Engineering Faculty Research & Creative Works by an authorized administrator of Scholars' Mine. This work is protected by U. S. Copyright Law. Unauthorized use including reproduction for redistribution requires the permission of the copyright holder. For more information, please contact [scholarsmine@mst.edu](mailto:scholarsmine@mst.edu).

# **Pre-College Engineering Activities with Electronic Circuits (Work-in-Progress)**

Jacquelyn Kay Nagel and Steve E. Watkins

James Madison University, Harrisonburg, Virginia, USA  
Missouri University of Science and Technology, Rolla, Missouri USA

## **Author Biographies**

### **Dr. Jacquelyn Kay Nagel, James Madison University**

Jacquelyn K. Nagel is an Assistant Professor in the Department of Engineering at James Madison University. She has eight years of diversified design experience, both in academia and industry, and has experienced engineering design in a range of contexts, including product design, bio-inspired design, electrical and control system design, manufacturing system design, and design for the factory floor. Dr. Nagel earned her Ph.D. in mechanical engineering from Oregon State University and her M.S. and B.S. in manufacturing engineering and electrical engineering, respectively from the Missouri University of Science and Technology. Dr. Nagel's long-term goal is to drive engineering innovation by applying her multidisciplinary engineering expertise in instrumentation and manufacturing technologies.

### **Dr. Steve E. Watkins, Missouri University of Science & Technology**

Steve E. Watkins is Professor of Electrical and Computer Engineering at Missouri University of Science and Technology, formerly the University of Missouri-Rolla. His interests include educational innovation. He is active in IEEE, HKN, SPIE, and ASEE including service as the 2015-17 Zone III Chair and the 2009 Midwest Section Chair. His Ph.D. is from the University of Texas at Austin (1989). Contact: [steve.e.watkins@ieee.org](mailto:steve.e.watkins@ieee.org)

# **Work in Progress – Pre-college Engineering Activities with Electronic Circuits**

## **Abstract**

Projects involving engineering experimentation, design, and measurement can be effective content for pre-college STEM outreach. Such applications-oriented activities can promote literacy and interest in technical topics and careers and have the added benefit of showing the relevance of science and mathematics. Exposure to electrical engineering concepts is discussed using the 555 timer integrated circuit. This low-cost device can be used for modular activities involving the production of light, sound, and motion. Specific projects are presented that are appropriate for pre-college students from 9<sup>th</sup>-grade through 12<sup>th</sup>-grade.

## **Introduction**

Engineering content, the “E” in STEM, can excite pre-college students about technical subjects and help them understand the technologies supporting everyday life. Engineering experimentation, design, and measurement can appeal to students’ curiosity and show the relevance of science, mathematics, etc. However, electrical engineering can be challenging to relate to pre-college audiences since the operation of circuits is less obvious than aspects of many other engineering fields, such as the structure of a bridge. Activities and demonstrations can be constrained by factors of equipment cost, available time, and audience background knowledge. The 555 timer integrated circuit (IC) is used to address these issues.

This work-in-progress describes the resources for pre-college activities with the 555 timer IC. The progressive modular activities that start with building a base circuit were implemented during a two-day engineering session “The Electronics of Everyday Things” that was offered during a high-school summer camp. The resources were developed over a three-year period for a mixed audience of students interested in studying engineering, geology, chemistry, biology, math, technology or physics in college. Thus, the objectives of these activities are to expose students to engineering concepts and practice, introduce electrical concepts and hardware, and offer a hands-on experience that can help pre-college students make an informed decision on if engineering is something they find interesting and might want to pursue as a career. The learning approach and content for the activities were improved during the preliminary implementations to provide flexibility of use for various instructors (faculty, engineering students, or pre-college teachers), pre-college audiences, and time constraints.

## **Pre-College Environment**

### **A. Approach to Activities**

The activities were structured as modules to provide flexibility for implementation in differing environments. Each engineering activity started with presentation of the needed technical concepts and a demonstration and was followed by a hands-on task for the students. Additional information and assistance was provided periodically during the experimentation. Each module ended with a discussion of what was learned and how it could be further applied.

## B. The 555 Timer IC

The 555 timer integrated circuit (IC) is an industry-standard, general-purpose timer design<sup>1</sup>. Although introduced in 1971, it continues to have a large application space, especially for students and hobbyists<sup>2</sup>. The name “555” comes from internal use of three 5k-Ohm resistors. The basic chip has eight pins – ground, trigger, output, reset, control, threshold, discharge, and power. The typical power supply requires 15-V or less and the output pin (typically 1.5 V and 200 mA) can drive a host of components, e.g. LEDs, Motors, and buzzers. The IC design longevity stems from its low cost, ease of use, and stable operation<sup>2</sup>. Common applications are the generation of pulses, oscillator waveforms, and timing signals. External resistors and capacitors control timing delays and operating frequencies. A versatile application circuit using this IC requires a power supply (e.g. a 9-V battery), a breadboard, a few resistors, capacitor(s), and an output device.

With this IC providing versatile functions in a low-cost and easy-to-use package, circuits can be constructed quickly to address such questions as “What makes a light blink and a buzzer sound?” or “What happens internally when a button is pushed?” Design, e.g. changing the output function and changing the circuit timing, can be incorporated with simple component additions. Tailoring activities for pre-college pedagogy and grade-level appropriateness can be readily done<sup>3</sup>. Also, an introduction to this IC facilitates understanding of related online hobbyists resources and can be a good transition to other IC hardware.

### Modular Resources

Six modular activities were developed for a two-day outreach experience – four involving circuit manipulation and two involving reflection. The activities are modular so that they can be done separately, expanded or contracted (time), or tailored to available components or student ability. For example, advanced students can engage in extra challenges that involve exploring deeper relationships. Students work in pairs during circuit manipulation activities. Two of the circuit activities are described in detail in this section. The associated circuit layouts are shown in Figure 1. The example output involves the production of light, sound, and motion that are related to the operation of everyday devices, e.g. telephone, appliances, and toys.

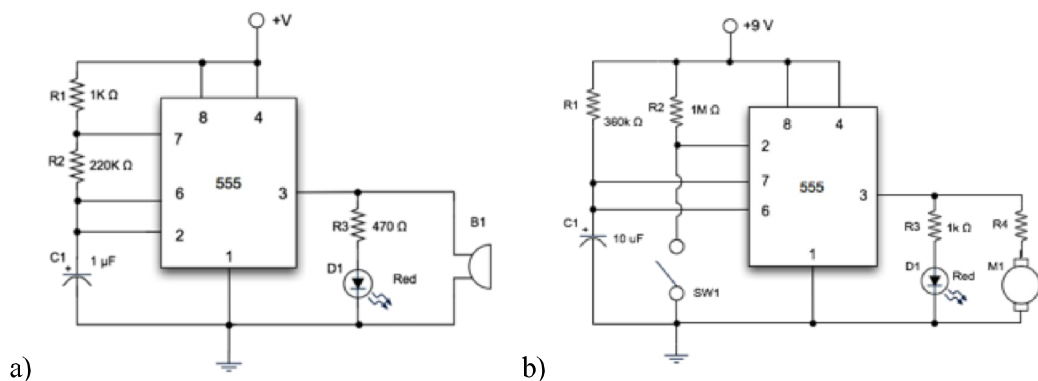

Figure 1. a) Flashing LED Circuit with Buzzer Output; b) Switching Circuit with Motor Output

## A. Activity: Flashing LED

Light emitting diodes (LEDs) are used in several products as indicators to let the user know that something is happening, such as the device is on. The 555 timer outputs a 3-Hz square wave that causes an LED to flash at a rate of 3 flashes per second while power is applied. This activity has three parts: 1) base circuit build, 2) changing a component to allow adjustment of the circuit output, and 3) addition of parallel output. A complete procedure with textual instructions is provided to assist the students with prototyping the circuit in Figure 1a on the breadboard. Advanced students can try changing the flash rate using a light sensor instead of resistor R2.

## B. Activity: Switching Circuit

Light emitting diodes (LEDs) and buzzers are used in several products as indicators to let the user know that something is happening, such as a button has been pressed. In this circuit, the 555 timer generates an output pulse that causes the output to stay on for the duration of the pulse, indicated by an LED and a buzzer or motor, once the switch is activated. This activity has three parts: 1) base circuit build, 2) designing a parallel circuit for the circuit output, and 3) changing the circuit output timing all in the context of designing a circuit for a game. A complete procedure is provided to assist the students with breadboard prototyping in Figure 1b. Advanced students can be guided in early re-design or measurement activities.

Each team is tasked with prototyping a circuit for a new game in which a contestant buzzes in with the answer. When the button is pressed, the light (LED) and buzzer should turn on for 5 seconds to allow the person asking the question to know who pushed the button first. First, students build the circuit in Figure 1b. Once the circuit is tested for an output of five seconds they move on to designing the parallel output that includes a motor and current limiting resistor.

Sticking with the game context the prompt for part 2 is the following: *Your boss liked the circuit prototype, but thought the buzzer was getting annoying and was outdated. She wants you to try something different and hands you a small motor typically found in a powered toothbrush and says, "Use the motor to spin something while the LED is on. This will make the product unique and interesting."* Students are informed that in order to add the motor to the circuit output a current limiting resistor is needed to protect the 555 timer from harm if the current drawn by the motor is too high. Students are instructed to calculate the value of resistor R4 needed to limit the current to 100 mA assuming the voltage of the motor is 5 V. This calculation reinforces the use of multimeter measurements, as the total voltage of the output must be known.

Once the motor output is prototyped and working, the students are challenged to re-design timing of the output for part 3 using the following prompt: *Again, you impressed your boss and your product went to local focus groups for trials. Almost everyone in the focus groups had the same feedback - They liked the motor and LED output, but thought the output was on for far too long. The circuit is almost finalized for production. Your team's final task is to reduce the circuit output from 5 seconds to 1 second.* To make the change to the output, the students must design a new value for resistor R1 using the 555 timer datasheet, a potentiometer, or trial and error. Students are reminded that resistors come in standard values and they may not be able to choose the exact value calculated, but should choose a component close in value.

### C. Other Activities

*Measurements* - A complete procedure is provided for taking voltage and current multimeter measurements on the 555 timer output and calculating Ohm's law values for comparison. Hence, experience is provided with engineering equipment and experimental practice.

*Reverse Engineering* - Reverse engineering is very common in consumer, industrial, and scientific designs. In this activity students are challenged to consider what else they could change (e.g. output pulse length) or for what other purposes could the circuit be used, and then prototype the design using the given set of components.

*Mid-point Reflection* – Answering reflection questions after completing the flashing LED and multimeter measurements assists the students with connecting theory to practice and application.

- Explain the mathematical relationship between voltage, current, and resistance.
- Explain how engineers could use a digital multimeter when prototyping circuits.
- Why might calculations be different from actual measurements?
- What changed when the potentiometer and/or light sensor replaced the 220 k $\Omega$  resistor?
- What products could the Flashing LED circuit be integrated into to add functionality?

*End Reflection* - Students end the set of activities with answering reflection questions that assist them with thinking through what they learned and their own interest in engineering.

- What is your declared major and university/college?
- What did you learn about engineering from this session?
- What part of the session was the most difficult or scary?
- What part of the session did you like the most?
- Overall, did you enjoy this session? Why or why not?

### **Implementation and Preliminary Assessment**

The pre-college engineering activities with the 555 timer IC were implemented during a summer camp with all activities completed in two, three-hour sessions. The activities and resources were developed over a three-year period for a mixed audience of students using instructor observation and the mid and end reflections. A summary of how the activities and resources evolved is provided in Table 1, which can help other educators craft their experiences. All students in the summer camp successfully completed the activities with the majority having no prior experience with circuits. Some teams required more assistance and encouragement than others. The reflection statements provided a qualitative assessment of how the students were internalizing the content from learning and personal interest viewpoints. Mid-point reflections indicated that most students were learning observation and deduction skills with some mastering electrical concepts. Students expressed difficulties such as reading schematics and datasheets or using the breadboard, and that circuits were intimidating. A working circuit was the most common response for what students liked the most, along with reverse engineering and the opportunity to explore/use different lab equipment and components. Students not interested in engineering careers found value in the exposure to experimental procedures, design content, and the application of math. Overall, the reflections indicated that most students learned something new about engineering, and felt that engineering is interesting and challenging.

Table 1: Evolution of 555 Timer Activities and Resources

	<b>Math</b>	<b>Application of Design</b>	<b>Project Worksheets</b>
Year 1	None	Define R1 and C1 values using 555 datasheet to design output pulse length, reverse engineering	Provided description of parts (Power supplies, breadboards, 555 timer IC, resistors, capacitors, LEDs, and buzzer) and multimeter
Year 2	Ohm's law calculations	Define R1 and C1 values using 555 datasheet to design output pulse length, define R4 value using calculations, reverse engineering	Added detail to all procedures, added extra challenges for advanced students, added more design and math steps, embedded short answer questions to help students recognize relationships
Year 3	Ohm's law calculations	Define R4 value using with C4 value constrained, reverse engineering	Refined all procedures, moved extra challenges to separate sections, removed short answer questions in procedure, added images next to procedure steps, added a game show scenario

### Summary

This work-in-progress describes resources that were developed for a two-day engineering summer camp for students in grades 9-12. The versatile 555 timer IC was chosen as a central component for these activities and electronic functions were matched to the theme of "The Electronics of Everyday Things." Modular resources allow application in many other settings, e.g. engineering career presentations, campus visit programs, and one-day or multiple-day outreach events. The resources include exposure to basic circuit components, electrical fundamentals (Ohm's law), breadboard prototyping, measurements, and calculations in addition to general problem-solving and experimental procedures. The re-design and reverse engineering aspects highlighted the creativity of the students. Some interesting student work included doorbell indicators for the deaf and rhythmic buzzer music. Qualitative assessment indicates that the activities are successful at exposing students to engineering, getting them to consider careers in engineering, and introducing electrical concepts and hardware through a hands-on experience.

Much of the development was focused on tailoring the activities to the time available and to pacing the information for the student audience. In particular, the mathematics content and design guidance were expanded. Effective implementation, e.g. how much instruction is needed and how much independence is given, depends on the experience and math/physics background of the student audience. Much of the work is self-paced so that additional challenges can be given to advanced students while assistance can be given to less experienced students. Future work includes quantitative assessment of students' learning of electrical concepts and hardware and influence on perception of engineering. A detailed description of and schedule for the activities and resources are available upon request.

### References

1. Texas Instruments, "LMC555," Includes datasheet. (2016). Available <http://www.ti.com/product/LMC555>.
2. B. Santo, "25 Microchips that shook the World," *IEEE Spectrum*, **46**(5), 34-43 (2009).
3. S. Kesidou and M. Koppal, "Supporting Goal-based Learning with STEM Outreach," *J. of STEM Education*, **5**(3/4), 5-16 (2004). Available: <http://jstem.org>.