

# Power Consumption Reduction for Wireless Sensor Networks Using A Fuzzy Approach

Giovanni Pau\*

Faculty of Engineering and Architecture, Kore University of Enna, Italy.

Received 09 November 2015; received in revised form 08 December 2015; accepted 15 December 2015

## Abstract

The increasing complexity of Wireless Sensor Networks (WSNs) is leading towards the deployment of complex networked systems and the optimal design of WSNs can be a very difficult task because several constraints and requirements must be considered, among all the power consumption. This paper proposes a novel fuzzy logic based mechanism that according to the battery level and to the ratio of Throughput to Workload determines the sleeping time of sensor devices in a Wireless Sensor Network for environmental monitoring based on the IEEE 802.15.4 protocol. The main aim here is to find an effective solution that achieves the target while avoiding complex and computationally expensive solutions, which would not be appropriate for the problem at hand and would impair the practical applicability of the approach in real scenarios. The results of several real test-bed scenarios show that the proposed system outperforms other solutions, significantly reducing the whole power consumption while maintaining good performance in terms of the ratio of throughput to workload. An implementation on off-the-shelf devices proves that the proposed controller does not require powerful hardware and can be easily implemented on a low-cost device, thus paving the way for extensive usage in practice.

**Keywords:** wireless sensor networks, fuzzy logic controller, power consumption, IEEE 802.15.4

## 1. Introduction

Technology advances in chip miniaturization, energy consumption and wireless communication have enabled the development and the deployment of new applications based on Wireless Sensor Networks (WSNs) [1]. A WSN is an ad-hoc network composed of tiny devices with limited energy and computational resources, and it equipped with sensors in order to gather physical measures from the monitored environment. A lot of research effort has been spent on WSNs and many architectures [2,3] and protocols [4,5] have been developed. Typical civil WSNs are basically not complex monitoring systems, whose applications encompass environment and habitat monitoring [6,7], home automation [8,9], industrial sensing [10,11] and intelligent transportation systems [12,13]. In these WSNs, sensors gather the required information, mostly, according to a fixed temporal schedule, and send it to the sink, which interfaces with a server or a computer. Only at this point data from sensors can be processed, before being stored.

A WSN is composed by several nodes that communicate among each other through a wireless channel. These nodes are typically battery-powered, and equipped with low-performance processors and small memories in order to reduce the power requirements. It is useful to note that a common WSN node comprises five main components [14]: a processing unit (microcontroller, processor, FPGA, ...), memories (DRAM, SRAM, Flash, ...), sensors and actuators, multiple communication

\* Corresponding author. E-mail address: [giovanni.pau@unikore.it](mailto:giovanni.pau@unikore.it)

Tel.: +39-0935-536494; Fax: +39-0935-536623

layers (physical radio, Medium Access Control, Routing, ...) and a power supply (external power supply, batteries, solar cells, ...). During the design phase, the cooperation of all these components must be combined in order to identify the configuration that best fits the design objectives.

Recent advances in low power transceivers and microprocessor dimensions have led to cost effective tiny sensor devices that combine sensing with computation, storage and communication. However, one of the major issues in WSNs is the power consumption, due to the fact that sensors are mainly battery powered. For example, a battery-operated sensor device that wakes up once every few minutes to check an environmental parameter needs to consume as little power as possible in order to minimize the battery replacement. In several cases, nodes are deployed in harsh environments, such as underground or underwater, where replacing battery could be an unfeasible operation. Extending the network lifetime is a crucial concern. In fact, there is a main requirement that make a wireless protocol ideal for use in the WSNs, that is the energy efficiency.

A great deal of effort has been made by researchers to find effective strategies in order to increase network lifetime. These strategies encompass network node deployment, routing mechanisms and data aggregation. In fact, an appropriate node deployment is probably the most critical issue to be addressed in order to reduce communication costs within a WSN [15]. Subsequently, once the network is deployed, the use of appropriate routing mechanisms could help to considerably increase its lifetime because a convenient choice of paths to route data may result in significant energy conservation. Therefore, network lifetime optimization can be achieved not only with the reduction of packet transmission power, but also with the involvement of data processing in order to reduce the amount of data delivered to sinks; this is the principle behind node clustering protocols [16].

The energy consumption in WSNs is determined by three main components that are sensing, processing and transmission. Sensing energy consumption for sensor node is determined by the specific characteristics of the sensor, and its value is determined based on the device datasheet. On the contrary, processing energy consumption  $E_{i,k}^{proc}$  for sensor node  $i$  and task  $k$  is proportional to the complexity of task  $k$  (the number of instructions  $I_k$  needed to complete it) and to the average energy consumption per instruction  $E_i^{ins}$  related to node  $i$ . This relationship can be expressed as follows:

$$E_{i,k}^{proc} = I_k \times E_i^{ins} \quad (1)$$

Furthermore, as shown in [17], there are two main components that must be taken into account, which are the transmission and reception energy consumption:

$$\begin{cases} P_{ij}^T = P_i^{T0} + P_i^A(\delta_{ij}) = P_i^{T0} + \frac{P_i^{Tx}(\delta_{ij})}{\eta_i} \\ P_j^R = P_j^{R0} \end{cases} \quad (2)$$

where  $P_{ij}^T$  and  $P_j^R$  are radio frequency power consumption values for transmitting and receiving respectively;  $P_i^A(\delta_{ij})$  is the power consumption of the Power Amplifier (PA), which depends on the distance  $\delta_{ij}$  between transmitting node  $i$  and receiving node  $j$ ;  $P_i^{T0}$  and  $P_j^{R0}$  are the components of power consumption of the transmitting and receiving circuitry respectively;  $P_i^{Tx}$  is the output power at node  $i$  antenna which, for reliable transmissions depends on the distance  $\delta_{ij}$ ;  $\eta_i$  is the drain efficiency of the PA at node  $i$ . Considering a channel in which the path loss component is predominant, the transmitted power  $P_i^{Tx}(\delta_{ij})$  can be expressed as follows:

$$P_{ij}^{Tx}(\delta_{ij}) = P_j^{Rx} \times A_{ij} \times \delta_{ij}^{\alpha PL} \quad (3)$$

where  $A_{ij}$  is a parameter determined by the characteristics of the antennas (such as gain and efficiency) and  $\alpha PL$  denotes the path-loss exponent, which is about 2 for free space. This kind of modelling is typical of free space propagation but it might be extended taking into account other fading effects. Considering the equations 2 and 3, the following equation can be derived:

$$P_{ij}^T = P_i^{T0} + \frac{P_j^{Rx} \times A_{ij} \times \delta_{ij}^{\alpha PL}}{\eta_i} \quad (4)$$

Considering  $\varphi_{ij} = P_j^{Rx \min} \times A_{ij}$ , where  $P_j^{Rx \min}$  is the minimum reception power at node j for a reliable communication, the equation 4 can be written as follows:

$$P_{ij}^T = P_i^{T0} + \frac{\varphi_{ij} \times \delta_{ij}^{\alpha PL}}{\eta_i} \quad (5)$$

Defining  $E_{ij}^{Tx}$  the energy per bit necessary to transmit data at rate R from node i to its adjacent node j, and  $E_j^{Rx}$  the per-bit energy consumed to receive data at node j, then they can be written as follows:

$$\begin{cases} E_{ij}^{Tx} = \frac{P_{ij}^T}{R} = \frac{1}{R} \left( P_i^{T0} + \frac{\varphi_{ij} \times \delta_{ij}^{\alpha PL}}{\eta_i} \right) \\ E_j^{Rx} = \frac{P_j^R}{R} = \frac{P_j^{R0}}{R} \end{cases} \quad (6)$$

Although several approaches have already been proposed in the literature in order to improve the energy management in a WSN, the use of innovative approaches based on soft computing techniques may be a viable solution in order to obtain an optimal power consumption management in a WSN.

The soft computing techniques fit themselves well in WSN applications, since they have been proposed for the construction of new generation artificial intelligence (high machine intelligence quotient, human-like information processing) and for solving non-linear and mathematically un-modeled systems. The use of rule-based Fuzzy Logic Controllers (FLCs) [18] enables the implementation of multi-criteria control strategies. Fuzzy logic is widely adopted in WSNs because it can deal with uncertain and vague values, such as the interference between two nodes or their estimated distance. In these cases, an accurate computation may be too complex and it could also be meaningless due to the quick change of the network conditions. On the contrary, the use of smart setting and tuning techniques for FLCs can improve the energy savings in a WSN. For this reason, the FLCs, based on linguistic rules instead of inflexible reasoning, can be the right choice to describe a mechanism for energy saving in order to prolong the lifetime of network nodes.

To cope with the power consumption problem in WSNs, this paper proposes a novel fuzzy logic based approach in an environmental monitoring context. The proposed wireless network architecture is based on the IEEE 802.15.4 protocol [19] and is organized in Environmental Monitoring Cells (EMCs). The energy saving of the network is obtained through a fuzzy module. In fact, the goal is to improve the low energy consumption of IEEE 802.15.4 through a fuzzy logic controller. The IEEE 802.15.4 protocol has been also chosen because it has a main advantage in its range since many IEEE 802.15.4 based technologies (e.g. ZigBee) support mesh whereby coverage can be extended by using routers. It is useful to note that this paper introduces a novel approach (not an application) to manage and to optimize the power consumption in WSNs.

The paper is organized as follows. In Section 2, the main related works in order to deduce the innovations introduced with this work are shown. In Section 3, the system architecture is described, while the fuzzy based approach and the considered membership functions are introduced in Section 4. In Section 5, the performance obtained by the proposed approach are shown and, finally, in Section 6, the paper is summarized, reporting conclusions and future works.

## 2. Related Works

Energy saving is one of the fundamental issue that characterize the WSNs because most wireless devices are usually battery-powered. Therefore, it is essential to manage these devices to best utilize the scarce power resources over long time. In the literature adequate and complete research works that describes the application of a fuzzy logic controller in order to reduce

the power consumption over WSNs are missing. In fact, different approaches, methodologies and technologies have been proposed in the literature in order to reduce the energy consumption of wireless sensor networks based on the IEEE 802.15.4 protocol. They achieve their goal but often their implementation is particularly difficult and requires modification of the stack protocol. On the contrary, in this paper, an approach to improve the energy consumption of a WSN nodes based on fuzzy logic is introduced, trying also to fill the gaps and difficulties in implementation of other approaches in the literature

The authors of [20] propose a better conditioned energy-saving frame format of an enhanced distributed queuing medium access protocol for body sensor networks based on IEEE 802.15.4 protocol in healthcare scenarios. In fact, the main aim is to overcome the limitations of the IEEE 802.15.4 MAC in order to obtain an improved energy efficiency. The approach proposed by the authors is evaluated analytically and the results show that it outperforms the IEEE 802.15.4 MAC in terms of overall energy-consumption per information bit. Whereby, the authors highlight that their approach represents a remarkable improvement of the overall network energy efficiency, which scales well for very dense body sensor networks and it is particularly suitable in medical scenarios.

A global study on energy considerations in the context of a wireless network based on the IEEE 802.15.4 technology is carried out in [21]. The authors want to emphasize that the lifetime announced by hardware manufacturer is clearly not suited when devices are used for networking. For this reason, they first show the impact of variable loads on battery chemistry reducing the node lifetime. In fact, these effects are non linear and are hardly predictable. Even at low duty cycle, the high currents needed for transmit/receive operations drastically reduce the node lifetime. Subsequently, the authors focus on the power consumption during the receive mode because it represents the worst case in terms of power consumption, at the end, they demonstrate the effectiveness of low power modes for increasing node lifetimes, obtained sacrificing the processing power in applications.

In [22], an approach for load balancing to fairly distribute energy consumption among nodes in IEEE 802.15.4-based WSNs is introduced. In fact, the proposed approach aims to conserve energy of each node in order to extend the network lifetime. In order to achieve this goal, the authors propose a new dynamic association/re-association approach allowing path alternation relative to association criteria and their threshold parameters. Simulations results show the efficiency of the approach proposed by the authors in term of both energy distribution, which leads to a longer lifetime, and lower latency, for real-time communication.

In [23], a reliable energy-efficient multi-level routing algorithm, based on a fuzzy inference system, for WSNs is proposed. The fuzzy-based approach proposed by the authors considers several network parameters, such as the residual energy, the number of neighbors' nodes and the centrality for cluster formation, which are critical for well-balanced energy dissipation of the network. The main aim of the fuzzy reasoning algorithm is to choose the cluster heads and to construct a multi-hop routing among cluster heads in an energy efficiently way. Simulation results demonstrate that the approach introduced by the authors obtains significant energy savings and, at the same time, prolongs network lifetime when compared to other approaches in the literature.

A fuzzy logic system is presented in [24] in order to save the battery life of WSN nodes and to have an efficient, robust and cost effective sensing network that can monitor events of interest, for example those of a home automation environment. The proposed fuzzy logic system helps efficiently to decide the situation of on/off state for active/sleep mode of the processing and communication parts of the sensor node. Simulation results show that the proposed system is energy efficient and have property of liveness, soundness, without any deadlock state during execution.

The authors of [25] present transmission power control algorithms, based on soft computing techniques, in order to reduce the energy consumption in wireless sensor network, without affecting its throughput. Two algorithms are proposed, one using artificial neural network and the other using fuzzy logic control. The experimental results show that the proposed algorithms

obtain a marked improvement in performance when compared to the conventional Medium Access Control protocol of IEEE 802.15.4 standard.

The analysis of these research works clearly has shown that fuzzy logic can be applied in order to reduce the power consumption in several contexts. Therefore, although IEEE 802.15.4 has a low power consumption, it is clear that a fuzzy mechanism could be introduced in order to further improve the power consumption in environmental monitoring applications.

### 3. The Proposed Network Architecture

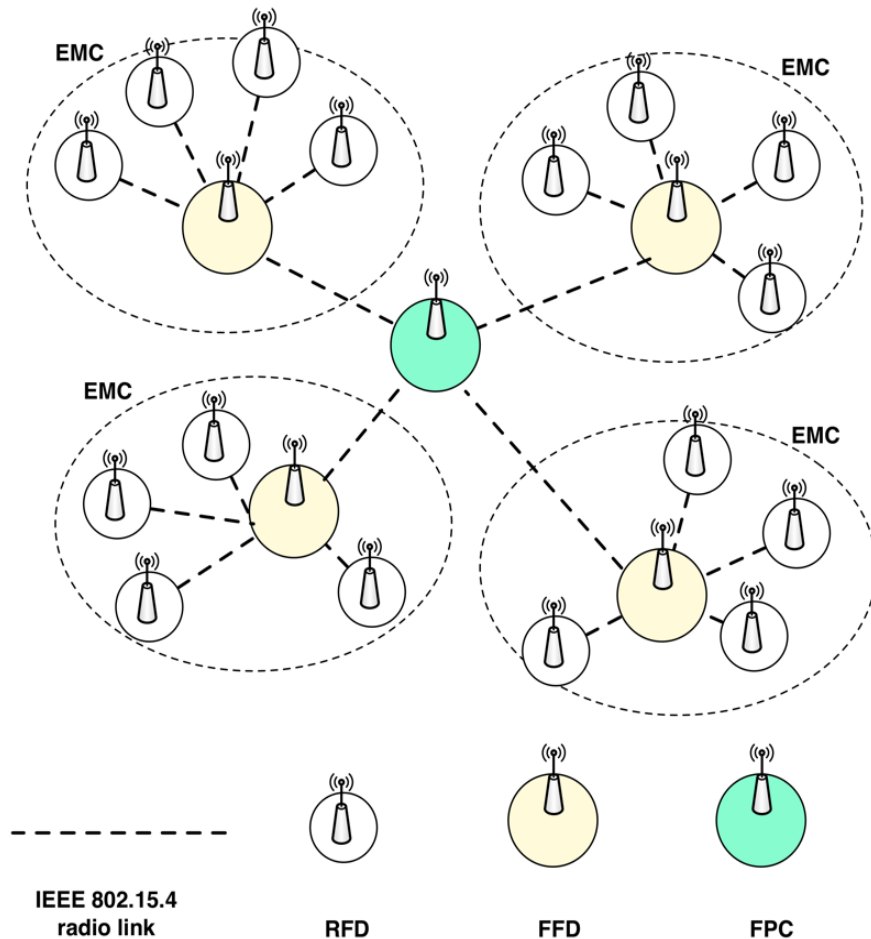

Fig. 1 Environmental monitoring IEEE 802.15.4 architecture

The main aim of this paper is not to satisfy all the requirements of a WSN, but rather to improve the power consumption. In Fig. 1, the proposed network architecture is depicted and is composed by several Environmental Monitoring Cells (EMCs) based on the IEEE 802.15.4 protocol [19]. This standard defines the physical layer (PHY) and data-link specifications (MAC) in order to ensure low data-rate wireless communications among devices requiring low power. The wireless network for environmental monitoring proposed in this work is composed by all the EMCs within which there are different devices dealing with a specific task. Reduced Function Device (RFD) nodes measure a physical parameter of the monitored environment, such as temperature, humidity, light, smoke density, carbon monoxide, etc.. Then, they send acquired data to their Full Function Device (FFD) nodes. An FFD node could be a ZigBee router [26]. It forwards data received from RFD nodes to the First Pan Coordinator (FPC) that processes information and send appropriate command messages to the sensor nodes.

It is useful to note that in IEEE 802.15.4 the transmission range varies considerably depending on the nature of the path that must be line of sight (LOS) for the most part. Transmit power level and receiver sensitivity are also factors to take into account. Under the best conditions, the range can be as great as 1000 meters with a clear outdoor path. Most applications cover a shorter range of 10 to 75 meters. Anyhow, it is necessary to take into account the energy consumption of the devices. For this

reason, the Energy Saving Fuzzy Controller proposed in this work, described in Section 4, is necessary in order to ensure the power consumption management. This module dynamically manages sampling times in order to prolong sleeping periods of sensor nodes. In this way, it is possible to improve the energy savings and, at the same time, prolong batteries and the network life-cycle.

#### 4. Energy Saving Fuzzy Controller

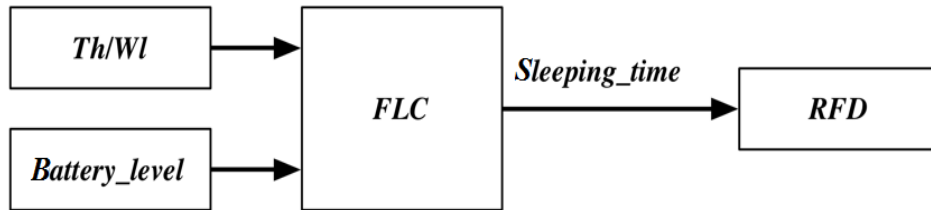

Fig. 2 Proposed FLC Architecture

Considering the proposed WSN, it is not possible to determine "a priori" the behavior of nodes since they are often used to monitor sporadic events. However, traffic flows generated by WSNs can be considered as periodic [27]. In this paper, a centralized mechanism is proposed in order to regulate the sleeping time of the field devices in a IEEE 802.15.4 network, with the aim of reducing their power consumption. Each RFD sends information about its operating conditions to the FPC when its sleeping time is expired. The FPC is a special device properly equipped for executing computational tasks. Anyhow, it is useful to note that generally in IEEE 802.15.4-based network the FPC nodes are not always battery powered. As shown in Fig. 2, in the proposed approach, the FPC node uses a Fuzzy Logic Controller (FLC) in order to calculate the new values of the *sleeping\_time* of each RFD. The FLC determines the *sleeping\_time* of the RFD according to the *battery\_level* and to the ratio of Throughput to Workload (*Th/Wl*). The throughput is the sum of both periodic and aperiodic packets sent by the device. The workload is the total number of packets that the device has to send.

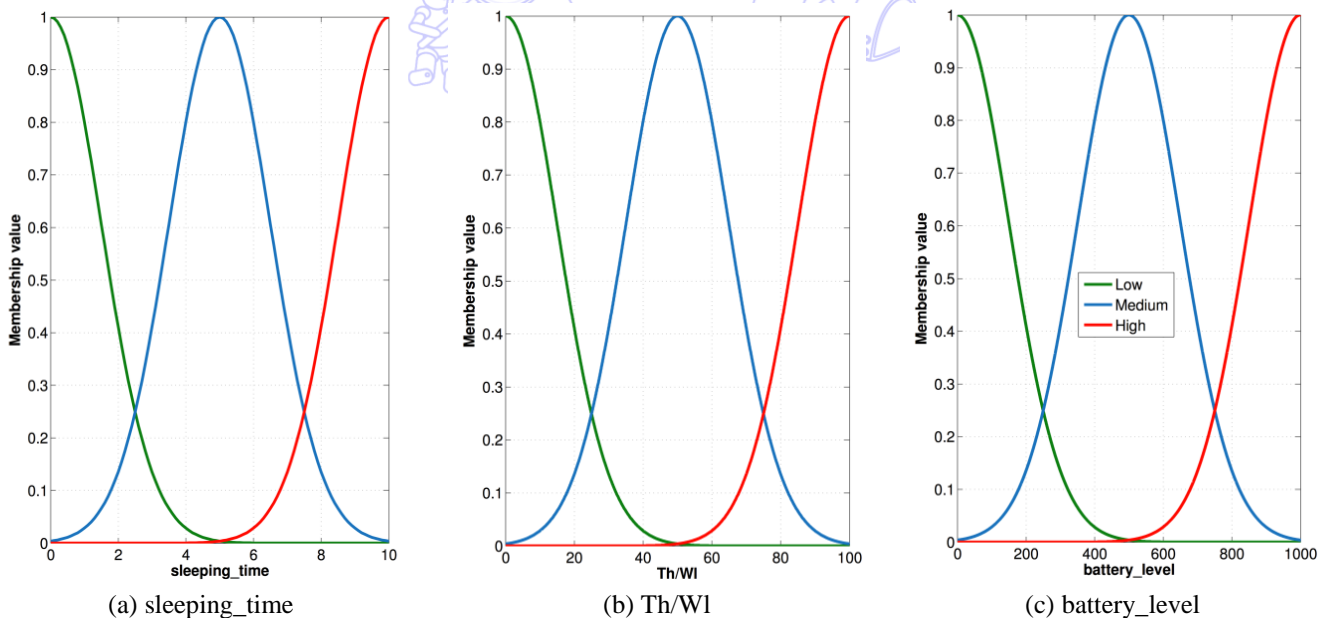

Fig. 3 Gaussian membership functions

The proposed FLC considers three membership functions (*Low*, *Medium*, *High*) for each input variable. These functions fuzzify the crisp inputs, while the ranges of which are:

- *Th/Wl* percentage: [0-100] (percentage);
- *battery\_level*: [0-1024], where 0 represents the lowest level of battery while 1024 represents the highest level of battery

and it is the maximum value at the output of a 10-bit AD converter (with an appropriate electronic signal conditioning circuit).

In the same way, three membership functions (*Low*, *Medium*, *High*) are defined for the *sleeping\_time*. In this case, the range of the crisp values of this output variable is:

- *sleeping\_time*: [0-10] \* *sampling\_time* (seconds).

where the *sampling\_time* value is a constant value defined at design time for each field device. Gaussian fuzzy membership functions of the *Th/Wl*, the *battery\_level* and the *sleeping\_time* are depicted in Fig. 3 respectively, where the degree of membership is represented by normalized values [0-1]. Considering that the Gaussian function [28] is defined by a central value  $m$  and a standard deviation  $k > 0$ , the smaller  $k$  is, the narrower the "bell" is, it can be represented as follows:

$$\mu_A(x) = e^{-\frac{(x-m)^2}{2k^2}} \quad (7)$$

Table 1 Values of variables

Universe of discourse	Set	k	m
Th/Wl	Low	15	0
	Medium	15	50
	High	15	100
battery_level	Low	150	0
	Medium	150	500
	High	150	1000
sleeping_time	Low	1.5	0
	Medium	1.5	5
	High	1.5	10

The different values of the variables are shown in Table 1. As shown in Table 2, the output value is determined through 9 fuzzy rules based on the IF-THEN statement of classic programming languages. For instance, considering rule 7, if *Th/Wl* is *High* and *battery\_level* is *Low*, *sleeping\_time* will be *High*. The outputs of the inference mechanism are fuzzy output variables. The FLC must convert its internal fuzzy output variables into crisp values, through the defuzzification process, so that the actual system can use these variables. Defuzzification can be performed in several ways. In this paper, the Centroid of Area (COA) method [29] has been chosen. In this method, the centroid of each membership function for each rule is first evaluated. The final output is then calculated as the average of the individual centroid weighted by their membership values as follows:

$$sleeping\_time = \frac{\sum_{i=1}^n Out_i * C_i}{\sum_{i=1}^n C_i} \quad (8)$$

Table 2 Inference rules

Rule	Antecedent (Th(Wl))	Antecedent (battery_level)	Consequent (sleeping_time)
1	Low	Low	Medium
2	Low	Medium	Low
3	Low	High	Low
4	Medium	Low	Medium
5	Medium	High	Low
6	Medium	Medium	Medium
7	High	Low	High
8	High	Medium	High
9	High	High	High

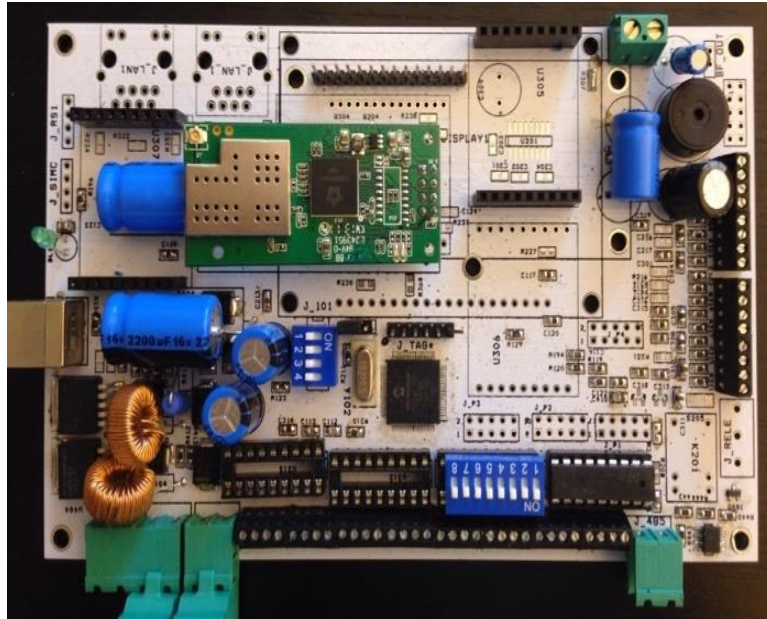

Fig. 4 Used prototyping board

## 5. Performance Evaluation

Using the proposed fuzzy-based approach, presented in the previous Section, several simulations have been performed. However, before showing the obtained results, it is necessary to describe the used simulation model. A generic star topology and a clustered one have been chosen for the performance evaluation. In a star topology, all the different nodes are required to talk only to the central PAN coordinator (FPC). Even if the nodes are FFDs and are within range of each other, in a star network topology, they are only allowed to communicate with the coordinator node. This does not occur in the other considered network topology. Both the FPC, FFD and RFD nodes have been implemented in a prototyping board, shown in Fig. 4, equipped with a micro-controller and a wireless module IEEE 802.15.4 compliant:

- 16 bit MCU - Microchip PIC24F family (PIC24FJ256GB108) [30];
- MRF24J40MB Radio Frequency Transceiver IEEE 802.15.4 2.4 GH [31].

The simulations have been conducted with a model built in Simulink/Matlab depicted in Fig. 5. The main aim of this model is to simulate the behavior of the coordinator node and of a sensor node, in the same way as the approach proposed in [32]. Specifically, the Sensor Node block manages the battery consumption of the RFD node. The *sleeping\_time* and the transmission power (TXPower) are acquired as input parameters of this block through a feedback loop system. This block produces two output variables (*Th/Wl* and *battery\_level*) that are used as input variables by the FLC.

It is useful to highlight that the activities of the micro-controller and of a connected sensor have a low impact on the battery consumption. In fact, their energy requirement is estimated as 50mA ( $MC_{PC}$ ). This value has been measured in an electronic board characterized by the PIC24FJ256GB108 micro-controller and a DS18B20 [33] temperature sensor. Whereby, the battery consumption mainly depends on the working state of the device. When the device is sleeping, the battery consumption is  $50\text{mA} + 5\mu\text{A}$  ( $5\mu\text{A}$  is the power consumption of the IEEE 802.15.4 module in sleeping mode, obtained from the datasheet [31]). On the contrary, when the device is transmitting, the transmission power heavily affects the energy consumption. The battery consumption trend is evaluated in relation to the sleeping time by means of the Simulink/Stateflow environment. This tool uses flow charts and finite state machines in order to represent the evolution of a system. The Chart section, created in Simulink/StateFlow, related to the behavior of the battery consumption is represented in Fig. 6.



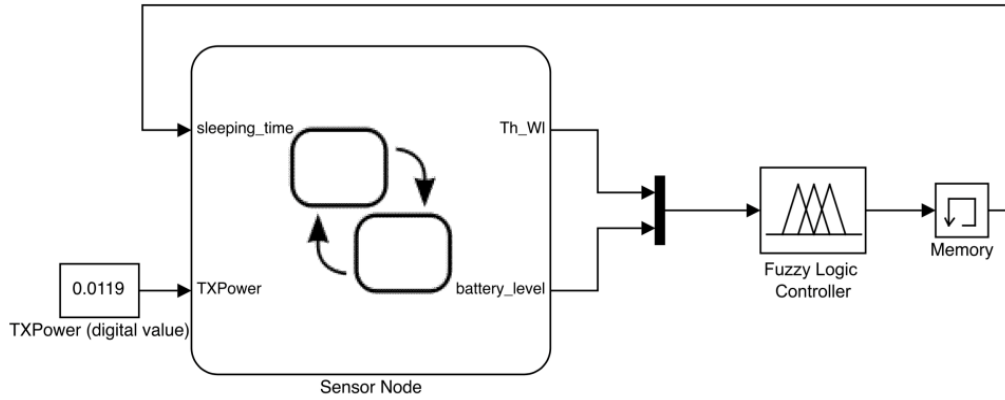

Fig. 5 Simulation model scheme

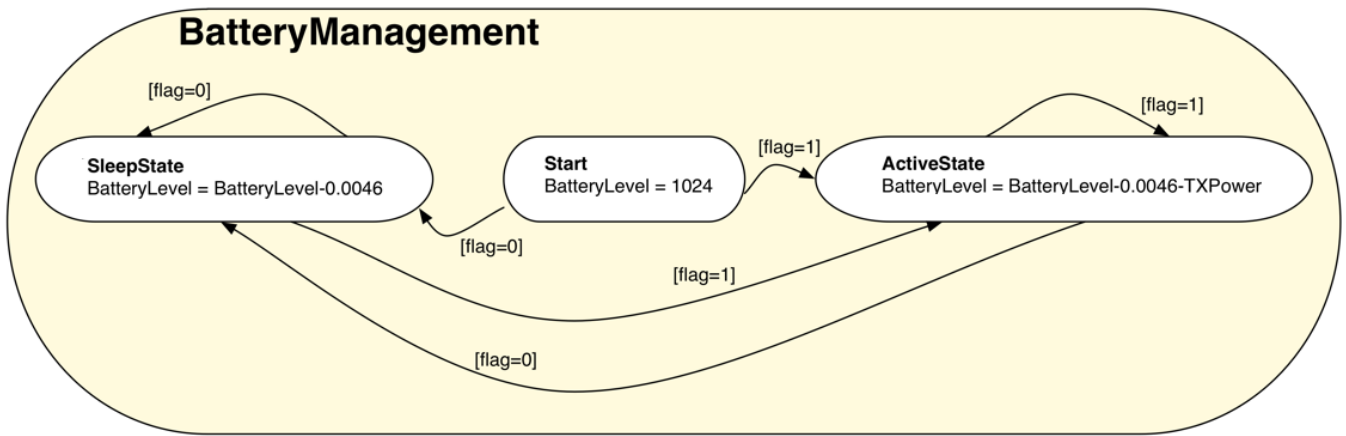

Fig. 6 Battery consumption flowchart

Considering a 10.8V lithium-ion battery, the maximum level of the battery when it is fully charged is 3100mA, while the corresponding digital value, acquired through a 10bit AD Converter, is 1024 (*MaxDV*). It is necessary to note that when the device is in sleeping mode, the power consumption is mainly due to the micro-controller and to the sensor, since the radio frequency transceiver consumption is negligible. In this case, the consumption is 0.0046bit/s. The following relation determines this value:

$$SleepMode_{consumption} = \frac{MC_{PC} * MaxDV}{FullBattery * 3600} \tag{9}$$

where 3600 is the number of seconds in an hour. By applying the equation 9 the power consumption of each device in sleeping mode is:

$$SleepMode_{consumption} = \frac{50 * 1024}{3100 * 3600} = 0.0046 \tag{10}$$

In case of maximum transmission power (0dB), the radio frequency transceiver consumption is 130mA [31]. As depicted in Fig. 5, the TXPower value is obtained as follows:

$$TransmissionMode_{consumption} = \frac{130 * 1024}{3100 * 3600} = 0.0119 \tag{11}$$

and it is necessary to underline that this value is fixed since the transmission power does not change dynamically in this paper. Finally, the proposed FLC takes the *Th/Wl* and the *battery\_level* as input variables and dynamically produces the *sleeping\_time*.

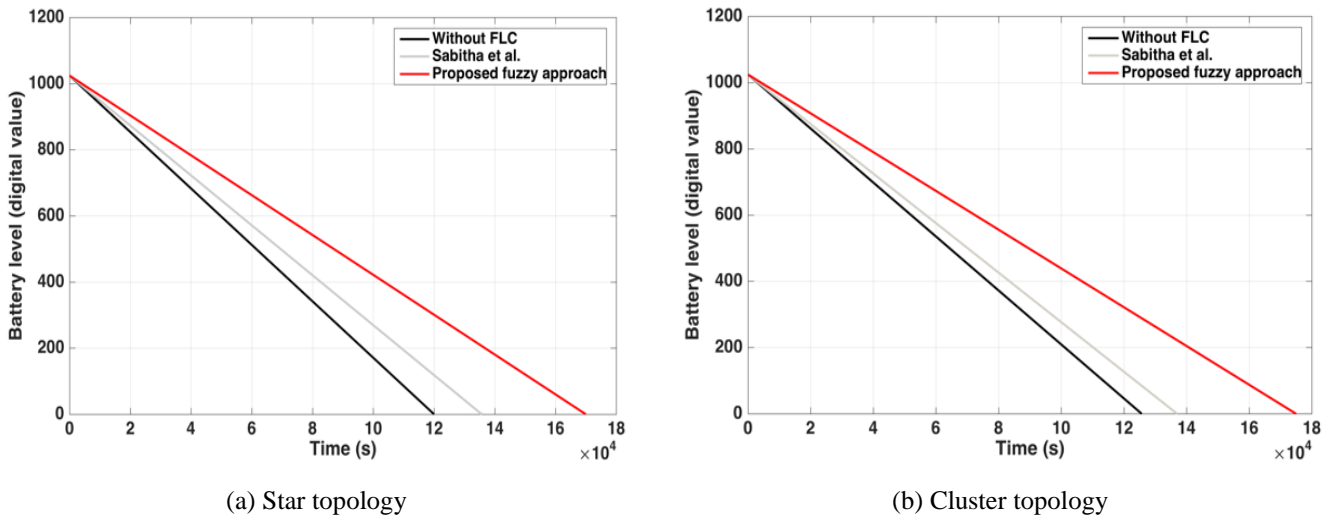
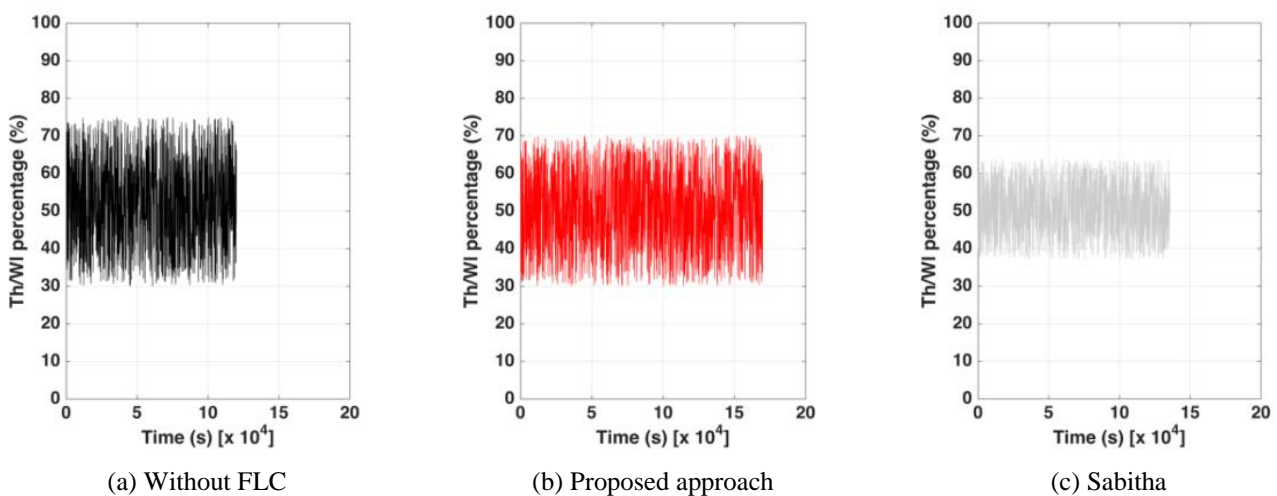

Fig. 7 Battery consumption comparison

During simulations, both the battery level and the ratio of Throughput to Workload ( $Th/Wl$ ) have been evaluated. The battery level during a simulation period of 48 hours is depicted in Fig. 7. In particular, using the proposed approach, a comparison has been carried out considering an approach without the FLC, i.e. assuming that the transmission power (0dB) and the sleeping time (equal to 1, coinciding with the sampling time) are both fixed and with the approach proposed by Sabitha et al. [25]. Fig. 7 clearly shows that the proposed fuzzy-based approach obtains a concrete power consumption reduction and, as a consequence, it prolongs the device lifetime. In both topologies, the best result is obtained by the proposed approach using Gaussian membership functions. In fact, the battery is fully discharged after 169,950s, i.e. after 47 hours and 21 minutes in the star topology and after is fully discharged after 174,945s, i.e. after 47 hours and 53 minutes in the cluster topology. This can be explained because, as shown in [34], using Gaussian membership functions the accuracy increases greatly, without degrading the computational performance. For this reason, the FLC based on Gaussian membership functions has been able to better manage the *sleeping\_time* of sensor nodes, prolonging much more the battery life. On the contrary, in the case without FLC, the battery is fully discharged much earlier, after 120,000s, i.e. after about 33 hours and 50 minutes in the star topology and after 125,671s, i.e. after about 35 hours in the cluster topology. Moreover, using the approach proposed by Sabitha et al. [25] the battery is fully discharged after 135,683s, i.e. after about 38 hours in the star topology and after 136,984s, i.e. after about always 38 hours in the cluster topology. Whereby, it is clear that the approach with Gaussian MFS has obtained an improvement of about 30% respect to the case without FLC.

Fig. 8  $Th/Wl$  behaviour on star topology [25]

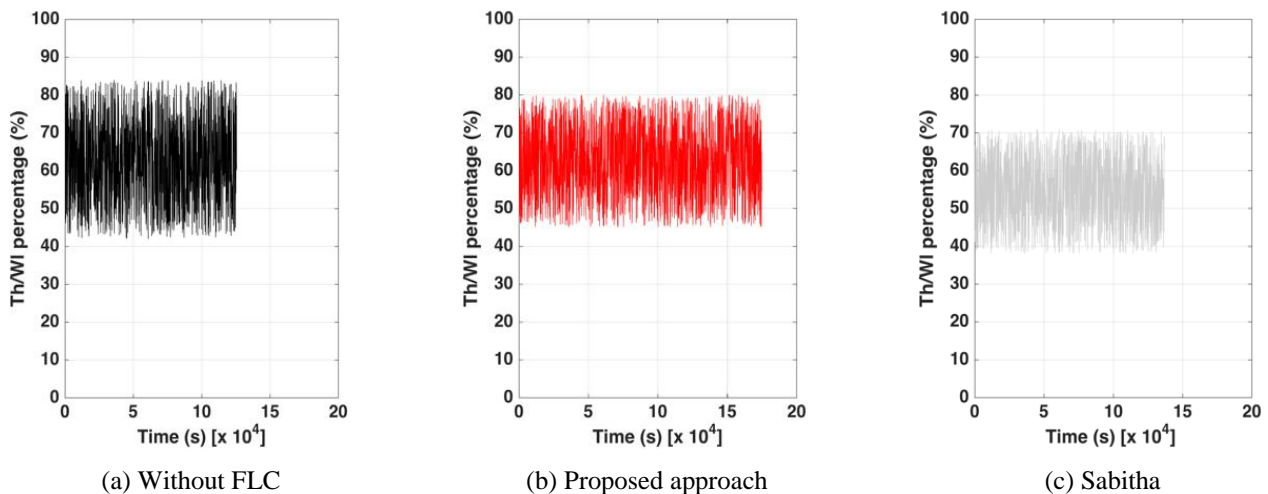

Fig. 9  $Th/WI$  behaviour on clustered topology [25]

During the simulation, the ratio of  $Th/WI$  have been evaluated and its behavior is depicted in Figs. 8 and 9. As it is possible to see, using the fuzzy-based approach proposed in this work the  $Th/WI$  fluctuates between 70% to 30% with Gaussian membership functions in the star topology and between 80% to 45% in the clustered topology. With the approach proposed by Sabitha et al. [25], the  $Th/WI$  fluctuates between 64% to 37% in the star topology and between 71% to 38% in the clustered topology. On the contrary, the values obtained without FLC fluctuate from 75% to 30% and 84% to 42% in the star and clustered topologies respectively, representing the best results in terms of the ratio of  $Th/WI$  but at the expense of the battery consumption. However, it is necessary to note that the values obtained with the proposed FLC, are acceptable especially in those application fields with a moderate variation of data, e.g. temperature, humidity or light detection, where the most important thing is to prolong, as much as possible, the battery lifetime rather than to ensure high  $Th/WI$  performance. On the contrary, the  $Th/WI$  behavior obtained with the proposed FLC would not be appropriate in a context characterized by real-time constraints, in which the *sleeping\_time* of network nodes should not be increased too much in order to obtain and ensure high values of the ratio  $Th/WI$ .

## 6. Conclusions

A fuzzy logic based mechanism has been presented in this paper in order to improve the lifetime of devices in a wireless sensor network for environmental monitoring. An analysis has been done on power consumption of WSNs in order to determine what are the factors to take into account and what approaches can be implemented in order to solve this problem. For this reason, even specific soft computing techniques, such as FLCs, can be used in such a way as to further reduce the energy consumption in a WSN. In fact, the fuzzy-based approach presented in this work dynamically changes the sleeping time in order to increase the battery duration of the sensor devices.

Simulations results have been very promising and demonstrate that using the proposed FLC a substantial reduction of the energy consumption is obtained compared to simulations carried out with fixed sleeping time. The results have been obtained using the Gaussian membership functions because an improvement of 30% has been achieved compared to the approach without FLC. Regarding to the  $Th/WI$ , using the proposed fuzzy-based approach a fluctuation between 70% and 20% has been measured and these values are acceptable especially in those application fields with a moderate variation of data where the most important thing is to prolong, as much as possible, the battery lifetime rather than to ensure high  $Th/WI$  performance.

Regarding future works, besides the analysis and the use of other membership functions, in order to further validate the proposed approach, several simulations will be carried out to make it suitable also in contexts characterized by real-time constraints.

## References

- [1] L. Borges, F. Velez and A. Lebres, "Survey on the characterization and classification of wireless sensor network applications," *IEEE Communications Surveys Tutorials*, vol. 16, pp.1860-1890, 2014.
- [2] J. Gustafsson, R. Kyusakov, H. Makitaavola and J. Delsing, "Application of service oriented architecture for sensors and actuators in district heating substations," *Sensors*, vol. 14, pp. 15553-15572, 2014.
- [3] D. K. Lee, T. H. Kim, S. Y. Jeong and S. J. Kang, "A three-tier middleware architecture supporting bidirectional location tracking of numerous mobile nodes under legacy WSN environment," *Journal of Systems Architecture*, vol. 57, pp. 735-748, 2011.
- [4] C. Buratti, A. Conti, D. Dardari and R. Verdone, "An overview on wireless sensor networks technology and evolution," *Sensors*, vol. 9, pp. 6869-6896, 2009.
- [5] P. Rawat, K. Singh, H. Chaouchi and J. Bonnin, "Wireless sensor networks: a survey on recent developments and potential synergies," *The Journal of Supercomputing*, vol. 68, pp. 1-48, 2014.
- [6] M. Collotta, G. Scata, S. Tirrito, R. Ferrero and M. Rebaudengo, "A parallel fuzzy scheme to improve power consumption management in Wireless Sensor Networks," *Proc. IEEE Emerging Technology and Factory Automation (ETFA)*, IEEE Press, Sep. 2014, pp. 1-4.
- [7] N. Dessart and P. Hunel, "Data collection using WSN for counting individuals and habitat characterization," *Journal of Computational Science*, vol. 5, pp. 624-632, 2014.
- [8] M. Collotta, G. Nicolosi, E. Toscano and O. Mirabella, "A ZigBee-based network for home heating control," *Proc. 34th Annual Conference of IEEE Industrial Electronics (IECON '08)*, IEEE press, Nov. 2008, pp. 2724-2729.
- [9] A. B. Gokbayrak, S. Divarci and O. Urhan, "Wireless sensor network gateway design for home automation applications," *Proc. Signal Processing and Communications Applications Conference (SIU)*, IEEE press, Apr. 2014, pp. 1770-1773.
- [10] M. Collotta, S. Tirrito, R. Ferrero and M. Rebaudengo, "An innovative parallel fuzzy scheme for low-power consumption in IEEE 802.11 devices," *Proc. 13th IEEE International Conference on Industrial Informatics*, IEEE Press, July 2015, pp. 908-913.
- [11] M. Collotta, L. Lo Bello, E. Toscano and O. Mirabella, "Dynamic load balancing techniques for flexible wireless industrial networks," *Proc. 36th Annual Conference on IEEE Industrial Electronics Society (IECON '10)*, IEEE press, Nov. 2010, pp. 1329-1334.
- [12] F. Losilla, A. J. Garcia-Sanchez, F. Garcia-Sanchez, J. Garcia-Haro and Z. J. Haas, "A comprehensive approach to WSN-Based ITS applications: A survey," *Sensors*, vol. 11, pp. 10220-10265, 2011.
- [13] M. Collotta, M. Denaro, G. Scata, A. Messineo and G. Nicolosi, "A self-powered wireless sensor network for dynamic management of queues at traffic lights," *Transport and Telecommunication*, vol. 15, pp. 42-52, 2014.
- [14] M. A. Pasha, S. Derrien and O. Sentieys, "System-Level synthesis for wireless sensor node controllers: A complete design flow," *ACM Trans. Des. Autom. Electron. Syst.*, vol. 17, pp. 02-24, 2012.
- [15] S. Sengupta, S. Das, M. Nasir and B. Panigrahi, "Multi-objective node deployment in WSNs: In search of an optimal trade-off among coverage, lifetime, energy consumption, and connectivity," *Engineering Applications of Artificial Intelligence*, vol. 26, pp. 405-416, 2013.
- [16] D. Wei, Y. Jin, S. Vural, K. Moessner and R. Tafazolli, "An energy-efficient clustering solution for wireless sensor networks," *IEEE Transactions on Wireless Communications*, vol. 10, pp. 3973-3983, 2011.
- [17] Q. Wang, M. Hempstead and W. Yang, "A realistic power consumption model for wireless sensor network devices," *Proc. 3rd Annual IEEE Communications Society on Sensor and Ad Hoc Communications and Networks (SECON '06)*, IEEE press, Sep. 2006, pp. 286-295.
- [18] L. A. Zadeh, "The concept of a linguistic variable and its application to approximate reasoning II," *Information Sciences*, pp. 301-357, 1975.
- [19] "Telecommunications and information exchange between systems- local and metropolitan area networks- specific requirements part 15.4: wireless medium access control (MAC) and physical layer (PHY) specifications for low-rate wireless personal area networks (WPANs)," *IEEE Standard Information for Technology*, Technical report, April 2006.
- [20] B. Otal, L. Alonso and C. Verikoukis, "Energy-Efficiency analysis of a distributed queuing medium access control protocol for biomedical wireless sensor networks in saturation conditions," *Sensors*, vol. 11, pp. 1277-1296, 2011.
- [21] N. Fourty, A. van den Bossche and T. Val, "An advanced study of energy consumption in an IEEE 802.15.4 based network: Everything but the truth on 802.15.4 node lifetime," *Computer Communications*, Special issue: Wireless Green Communications and Networking, vol. 35, pp. 1759-1767, 2012.

- [22] S. Ouni and Z. Ayoub, "Cooperative association/re-association approaches to optimize energy consumption for real-time IEEE 802.15.4/ZigBee wireless sensor networks," *Wireless Personal Communications*, vol. 71, pp. 3157-3183, 2013.
- [23] Z. Yu, X. Fu, Y. Cai and M. C. Vuran, "A reliable energy-efficient multi-level routing algorithm for wireless sensor networks using fuzzy petri nets," *Sensors*, pp. 3381-3400, 2011.
- [24] M. R. Tripathy, K. Gaur, S. Sharma and G. S. Virdi, "Energy efficient fuzzy logic based intelligent wireless sensor network," *Proc. Progress In Electromagnetics Research Symposium*, July 2010, pp. 91-95.
- [25] R. Sabitha, K. Bhuma and T. Thyagarajan, "Design and analysis of fuzzy logic and neural network based transmission power control techniques for energy efficient wireless sensor networks," *Proc. 3rd International Conference on Frontiers of Intelligent Computing: Theory and Applications (FICTA)*, Springer International Publishing, 2014, pp. 295-303.
- [26] T. Kalaivani, A. Allirani and P. Priya, "A survey on Zigbee based wireless sensor networks in agriculture," *Proc. 3rd International Conference on Trendz in Information Sciences and Computing (TISC)*, IEEE press, Dec. 2011, pp. 85-89.
- [27] O. Khader, A. Willig and A. Wolisz, "Distributed wakeup scheduling scheme for supporting periodic traffic in wsns," *European Wireless Conference*, pp. 287-292, 2009.
- [28] I. A. Hameed, "Using gaussian membership functions for improving the reliability and robustness of students' evaluation systems," *Expert Syst. Appl.*, vol. 38, pp. 7135-7142, 2011.
- [29] T. A. Runkler and M. Glesner, "DECADE - Fast centroid approximation defuzzification for real time fuzzy control applications," *Proc. ACM Symposium on Applied Computing(SAC '94)*, 1994, pp. 161-165.
- [30] Microchip Technology. PIC24FJ256GB108 - 16-bit PIC and dsPIC Microcontrollers, 2009.
- [31] Microchip Technology. MRF24J40MB - rfPIC, 2009.
- [32] M. Collotta, "FLBA: A fuzzy algorithm for load balancing in IEEE 802.11 networks," *Journal of Network and Computer Applications*, vol. 53, pp. 183-192, 2015.
- [33] Maxim Integrated. DS18B20 - Programmable Resolution 1-Wire Digital Thermometer, 2008.
- [34] V. O. S. Olunloyo, A. M. Ajofoyinbo and O. Ibadapo-Obee, "On development of fuzzy controller: The case of gaussian and triangular membership functions," *Journal of Signal & Information Processing*, vol. 2, pp. 257-265, 2011.

