

# Interdisciplinary Journal of Partnership Studies

Volume 3  
Issue 3 Fall

Article 1

10-14-2016

## Collaboration Guidelines to Transform Culture

Benjamin Heslop  
*University of Newcastle*

Kylie Bailey  
*University of Newcastle*

Jonathan Paul  
*University of Newcastle*

Antony Drew  
*University of Newcastle*

Roger Smith  
*University of Newcastle*

Follow this and additional works at: <http://pubs.lib.umn.edu/ijps>

### Recommended Citation

Heslop, Benjamin; Bailey, Kylie; Paul, Jonathan; Drew, Antony; and Smith, Roger (2016) "Collaboration Guidelines to Transform Culture," *Interdisciplinary Journal of Partnership Studies*: Vol. 3: Iss. 3, Article 1. Available at: <http://pubs.lib.umn.edu/ijps/vol3/iss3/1>



This work is licensed under a [Creative Commons Attribution-Noncommercial 4.0 License](https://creativecommons.org/licenses/by-nc/4.0/)

The *Interdisciplinary Journal of Partnership Studies* is published by the University of Minnesota Libraries Publishing. Authors retain ownership of their articles, which are made available under the terms of a Creative Commons Attribution Noncommercial license (CC BY-NC 4.0).



---

# Collaboration Guidelines to Transform Culture

## **Acknowledgements**

Mothers and Babies Research Centre, School of Medicine and Public Health, University of Newcastle

## COLLABORATION GUIDELINES TO TRANSFORM CULTURE

**BENJAMIN HESLOP, B.Eng (Systems), MPhil**

**KYLIE BAILEY, B.A. (Psych) M.Psych Clin, PhD (Psychiatry).**

**JONATHAN W. PAUL, B.Sc (Hons), PhD (Biological science)**

**ANTONY DREW, PhD (Management), MBA (Merit).**

**ROGER SMITH, MBBS, PhD (Medicine)**

### **Abstract**

Positive-sum behaviour arises when people expect a benefit from cooperation. This article argues that positive-sum behaviours give rise to a fairer, more civilized society; however, adoption of these behaviours is impeded by their complexity. For example, others' actions may seem unpredictable, while individual benefit may seem intangible. Consequently, adoption of positive-sum behaviours could be encouraged by explicit instructions. This article proposes guidelines and outcomes for healthy collaboration, which is a positive-sum behaviour.

**Keywords:** collaboration; psychopath; progressive; conservative; leadership; egalitarian; hierarchy; positive-sum; zero-sum; guidelines; religion

**Copyright:** ©2016 Heslop, et al. This is an open-access article distributed under the terms of the Creative Commons Noncommercial Attribution license (CC BY-NC 4.0), which allows for unrestricted noncommercial use, distribution, and adaptation, provided that the original author and source are credited.

### **GUIDANCE IN A COMPLEX WORLD**

Many aspects of the modern world are becoming less predictable. Climate change, terrorism, mass immigration, and national economies are commonly-heard sources of trepidation. Yet, theologians, politicians, and philosophers continue to provide guidance based upon ideas and theories that may be centuries old. Despite the real and growing complexity of modern society (Johnson & Johnson, 2014), many people continue to default to these widely accepted principles.

Their enduring popularity may in part be explained by a combination of simplicity and empirical evidence. For example, free-market economics and Darwinian evolution are both simple ideas with substantial evidence. For a more recent example, *social identity theory* (SIT) is a simple, proven idea that has entered the popular lexicon (Castells, 2010).

Henry Tajfel (1982) developed SIT to explain ‘intergroup behaviour,’ which manifests destructively as xenophobia, but more innocuously as tribalism or nationalism. People prefer to associate with, and be led by, those who act in ways consistent with their expectations of what is normal for their tribe. As a result, we are instinctively suspicious of those who seem different (Hogg & Turner, 1985).

### **Positive- and zero-sum perspectives**

Economics, evolution, and SIT are simple ideas, for which empirical evidence has been found. They also imply selfishness based upon a *zero-sum* calculation, meaning, “*What I gain is to your cost, and vice versa.*” A zero-sum calculation assumes that the size of the sum total of resources is fixed, much like a *pie chart*. This approach incites concern at another’s success, rather than celebration, because of a suspicion that it came at your cost (Deutsch, 1949).

Alternatively, taking a *positive-sum* perspective allows the possibility that the pool of resources, or pie, can become larger as a result of cooperation (Caruso & Woolley, 2008). Government regulation, building construction, and musical collaborations are all instances where *positive-sum* outcomes can be achieved (Rittel & Webber, 1973). Regulators scrutinise undesirable outcomes for both consumers and suppliers, such as monopolistic dominance or unsafe goods. Tradespeople work as a team, and rely upon each other’s specialisation. Artists inspire mutual creativity to produce novel work. The trade-off is that coordinating diverse actors and stakeholders, each possessing distinct emotions and motivations, increases complexity (Uphoff & Krishna, 2004).

### Attraction of simple ideas

Innate conservatism of individuals within both human and animal populations varies across a spectrum (Brosnan & Hopper, 2014). Wariness of change is often wise, given that any in particular may turn out to have undesirable consequences. When given the choice between simple and complex change, conservatives prefer simple ideas because they are more comprehensible, and intuitively seem more tractable.

This explains why, against the expectations of many, Donald Trump attracted substantial support among evangelical Christians (West, Gawley, & Jeffes, 2016). Trump took the simple, *zero-sum* perspective of the “prosperity gospel” (Clark & Rakestraw, 1995, p.343), which preaches that God wants his adherents to be rich. The prosperity gospel is simpler and more intuitive than Jesus’ golden rule of “do unto others” (Matthew 7:12). Catering to the feelings and interests of others is a difficult and often thankless task. Seeking one’s own enrichment is, by comparison, a simple and, at least to some, attractive, idea.

Policy makers also have reason to be attracted to credible, simple ideas (Warren & Gastil, 2015). It provides them clear justification for policy, even when its implementation might be detrimental to the majority. For instance, the idea that government debt is bad is based upon the false equivalency between government spending, and family or small business budgets (Smith, 2014). A darker example is the idea that unemployed people should not be helped because they are either economically unproductive by *choice* (lazy), or otherwise inherently *deficient* (an argument that is unlikely to be voiced outright but which may be insinuated). Yet, ignoring the destitute leads to many hidden costs, such as crime, mental illness, and increased demand on services, such as police and emergency departments (Doran et al., 2016; Roy, Crocker, Nicholls, Latimer, & Reyes-Ayllon, 2014).

Modern society is complex and challenging for us all, but especially for the less educated and for those who prefer simple, clear ideas (Guo, 2015). Leaders preaching simple solutions can find support from a fearful minority, and sometimes even a frustrated majority (Jost, Glaser, Kruglanski, & Sulloway, 2003). Therefore, to attract both the

general public and policy makers, any *positive-sum* idea must clearly explain *how* it would work in practice, and the *benefit* to people in implementing such a change.

### Thorngate's Postulate

Frustrated by the seeming impossibility of straightforward explanations for social phenomena, Thorngate (1976) proffered the *postulate of theoretical simplicity*. It states that it is impossible for a theory of social science to be simultaneously general, accurate, and simple [GAS] since "the more general a simple theory is, the less accurate it will be in predicting specifics" (Thorngate, 1976 p. 134). This postulate is highly relevant to complex *positive-sum* ideas, and an ensuing difficulty of formulating general, practical guidelines based upon them.

Arguably, evolution, economics, and SIT are *simple* ideas, but are they also general and accurate? SIT is *accurate*, but *not* general. For example, when a group is under external threat its members behave collectively, but otherwise they will tend to compete with each another (Haslam, 2004). By contrast, evolutionary self-interest and economic rationality are generally applicable, but neither are accurate predictors of behaviour (Henrich et al., 2005). For instance, economics assumes that people are purely rational; however *game theory* indicates otherwise. In game theory experiments, participants will sometimes sacrifice self-interest to punish another player, usually when that person is perceived to be acting unfairly (Koeslag, 1997).

To create *positive-sum* guidelines that circumvent the limitations of Thorngate's postulate, it may be possible to combine different ideas, one at the micro level, the other macro. Such a strategy has been successfully employed by insurgent movements such as ISIS. Their first *macro* idea is conveyed through welfare and public works, such as soup kitchens and policing (Zelin, 2014). It is (paraphrasing): *We take practical steps to help the community and supply order.*

Once the population have become engaged and accepting of the macro idea, a second, more explicit micro idea is introduced. In any occupied city, the governing mantra of ISIS

soon became; *Obey this list of edicts based upon our interpretation of Sharia law* (Rosen, 2014).

In a more pleasant milieu, Alain de Botton (2001) takes a similar approach when translating abstract philosophy into practical guidelines. For good or ill, a macro-to-micro strategy can alter behaviour of a population by progressing from *vague* simplicity to *explicit* complexity. The first serves as the easily comprehensible, ‘philosophical’ entry point with scant detail. Once people have engaged, they receive detailed guidance. We will now examine a candidate for a macro idea that conveys the *positive-sum* ethos.

## HUMAN POSSIBILITIES THEORY

*Human Possibilities Theory* [HPT] is founded on the hypothesis that human prehistory was predominantly egalitarian (Mealey, 1995). Archaeological evidence indicates that egalitarianism persisted in Europe from pre-agrarian foraging until early settlements, whereupon more warlike people invaded (Eisler, 1987). Corroborating this, remnant hunter-gatherer tribes have been observed to possess egalitarian political structures (Boehm et al., 1993). Furthermore, neuroscience shows we are genetically predisposed to prefer fair and just outcomes for others (Eisler, Dolan, & Raich, 2013). HPT characterises our historical egalitarianism as the *partnership system*.

Unlike mobile foraging, sedentary farming permits wealth accumulation and land ownership. When the land is fertile, and a production surplus easily obtained, *bastard feudalism* can arise. This is characterised by an aristocratic caste, with accompanying warrior class (North, Wallis, & Weingast, 2009). Bastard feudalism personifies zero-sum behaviour in two ways. Disputes with neighbours, and accompanying military investment, are justified with xenophobia [SIT]. Secondly, the aristocracy compete for power amongst themselves rather than governing for the common good [survival of the fittest] (Maner & Mead, 2010). HPT would term this resource-wasting, antagonistic environment the *domination system* (R. Eisler, 1987).

## **Domination and psychopathy**

Psychopathic, callous traits are adaptive within a domination system such as bastard feudalism (Boddy, 2010) Gervais, Kline, Ludmer, George, & Manson, 2013). Yet *primary*, or genetically programmed, psychopathy only occurs within 1% of modern humanity (Glenn, Kurzban, & Raine, 2011). Such a low preponderance may be a remnant from 6 million years that hominids, and then sapiens, spent in more-or-less egalitarian structures (Gervais et al., 2013). This data supports an assertion that a partnership system suppresses genetic psychopathy, while a dominance system encourages it.

Nevertheless, most occurrences of psychopathy are actually *secondary* in that they arise as an adaptation to a stressful social environment, especially during childhood (Kiehl, 2006). Being mistreated as a child reduces empathy and impulse control in the adult. This leads to poorer social skills and higher aggression, therefore criminality, and potentially mistreating others (Gao & Raine, 2010).

Through secondary psychopathy, once established, the domination system can become self-reinforcing (Baysinger, Scherer, & LeBreton, 2014; (Pasalich, Dadds, Hawes, & Brennan, 2012). An example is the bullying that occurs within elite boarding schools. Elder students have a reputation for bullying the younger students, who later become bullies themselves (Poynting & Donaldson, 2005).

## **CULTURAL TRANSFORMATION THROUGHOUT HISTORY**

Despite self-perpetuation of the domination system via secondary psychopathy, some advanced nations, particularly Scandinavian, have re-embraced the partnership system. This came about due to 19<sup>th</sup> century egalitarian power sharing between farmers, industrial workers, and the aristocracy (Alestalo & Kuhnle, 1987), assisted by gender equality (R. Eisler, 1987). Of course, this massive simplification ignores many cultural, geopolitical, and geographic factors that have subtly contributed to the region's character. It nevertheless demonstrates that the partnership system can still re-emerge (Ghosh, 2015), even after centuries of medieval feudalism that Scandinavia, and Europe more broadly, endured (Stokke & Törnquist, 2013).



Yet, a partnership system may also regress; following World War II the United States of America gave her people equality of opportunity, while at the local level Russia was collectively governed. Nevertheless, wealth inequality and political malfeasance are now growing in both nations (McElwee, 2015; Snegovaya, 2015). Advancing the prospect of reversing such trends, HPT has proposed the *Cultural Transformation Theory* (R. Eisler, 2015a, 2015b). Similar to water transitioning from ice to liquid, society can *phase shift*, or *bifurcate* between domination and partnership.

As alluded to already, shifting between domination and partnership may have originated in our simian forebears (Pierce & White, 1999). Almost instantaneously, chimpanzee troupes can shift behaviour in response to their environment, alternating between *agonic* (domination) and *hedonic* (partnership) modes (Drew & Kriz, 2012). The agonic mode is suited for centrally located food or for defending against predators. A steep hierarchy reduces squabbling and/or coordinates defence. The hedonic mode is suited for when food resources are widely spread. In this mode, individuals or small groups forage widely, and upon return to a central location, treat one another warmly (Pierce & White, 1999).

### **Cultural transformation through self-leadership**

The political left claim that redistribution of wealth is desirable. Yet, society at large benefits from the ‘greed is good’ *zero-sum* ethos because of it motivates economic activity. Rather than demonising capitalists for rational beliefs, it may be preferable to provide an expanded perspective (Ajzen, 1991; Haidt, 2001).

For instance, it is unhelpful to directly attack science sceptics for their ignorance. It is better to contextualise their claims as part of the imperfect, but nonetheless self-correcting, scientific establishment (Cook & Lewandowsky, 2011). To avoid defensiveness in the listener, *positive-sum* theory would ideally include a way to judge when *zero-sum* decisions are (and are not) optimal. After learning this theory, *self-leadership* would allow a more nuanced capacity to make decisions (Manz, 1986).

Therapy using this approach has succeeded with people who exhibit destructive behaviours: paedophiles (Pratt, 2014), child soldiers (Boothby, Crawford, & Halperin, 2006), and captured terrorists (Mink, 2015). In general, therapy centres around discussing their impacts on victims to create awareness and empathy. Realising the scale of their past crimes can, depending upon the individual, create the desire for an alternative decision framework. Given appropriate counselling followed by guidance, even psychopaths can learn to modify their behaviour (Reidy, Kearns, & DeGue, 2013; Wong & Olver, 2015).

Unfortunately, leaders who benefit from a domination system will generally prefer that it remain (Parker, 2016). Since the powerful cannot be easily converted, cultural transformation to a partnership system may require *grass-roots* acceptance of a *positive-sum* idea. For example, the conversion of the Roman Empire from polytheism that endorsed selfish hedonism, to Christianity that taught restraint and “love thy neighbour” (Khan, 2016; Potter, 2015).

### **Imprecise guidelines**

HPT is an attractive and powerful idea, yet very abstract. Providing more explicit guidance requires a second theory. An accurate theory, as Thorngate (1976) conceives it, permits detailed predictions. Conservatives seek stability and tradition, but in today’s uncertain world, predictive ability is the next best thing (Amodio, Jost, Master, & Yee, 2007). One must be careful, however, to avoid *positive-sum* guidelines being subverted by a domination system.

Examples of subversion of *positive-sum* guidelines are available from Buddhism, Hinduism and Christianity. Reincarnation is a reward or punishment for deeds committed in past lives. On face value, it is a *positive-sum* message that encourages good behaviour. It can however be subverted to justify mistreatment of lower castes, whose ongoing plight is framed as punishment for supposed past sins.

An example from Christianity is the prosperity gospel’s interpretation of the proverb “It is easier for a camel to go through the eye of a needle than for a rich person to enter

the kingdom of God” (Mark 10:25). At first glance, the proverb would seem unsympathetic to wealth accumulation. However, as opposed to actual laws, allegories by their nature leave room for interpretation.

Opportunities for subversion arise when a guideline requires, or is amenable to, interpretation. Unfortunately, for reasons described earlier (p. 3), there may be a temptation for the leader to choose simpler, *zero-sum* interpretations. In such a situation, their intended audience will face two inducements to adhere. Not only is the chosen interpretation attractively simple, but the leader can reciprocate with a *zero-sum* reward (Ruthven, 2012), for example, permitting their invading army to pillage a conquered city.

Avoiding subversion requires guidelines whose *clarity* prevents misinterpretation, with sufficient *brevity* to avoid inconsistencies. Social scientists would recognise this as *internal consistency*, in which objects within a theory are well-defined and invariantly manifest (Merton, 1968). Reliable *positive-sum* guidelines require internally-consistent theory, not only to avoid subversion, but also to allow adherents to predict one another’s behaviour. This in turn promotes peer-to-peer trust, which is a prerequisite for *positive-sum* cooperation (Yeager & Walton, 2011). Hence, cultural transformation to a partnership system requires a micro-level theory from which internally-consistent guidelines can be drawn.

## INGREDIENTS OF A COMPLEX THEORY

When building theory to describe a system, of which partnership is one, social scientists strive to define not only theoretical *constructs* but also effects between them, called *linkages* (Shoemaker, Tankard, & Lasorsa, 2004). In sympathy with HPT’s *relational dynamics*, nomenclature of *components* and *impacts* will be adopted (R. Eisler, 2016). Complexity of a theory increases with greater numbers of constructs and linkages.

Reflecting the need to address the micro-level, renowned social theorist Peter Senge has stated that HPT should develop theory describing the group (R. Eisler, 2015a). Groups

are omnipresent, which serves the GAS requirement for generality. The *International Journal of Partnership Studies* has published articles with candidate guidelines for group operation. TeamSTEPPS (Siddons & Potter, 2016) is a facilitated program to reduce conflict in a workplace. Intergalactic Leadership (Lonquist, 2015) is a set of eight principles, and associated tips, of leadership within a university administrative setting. Universal Human Needs guided Kashtan (2016) in facilitating progressive change to state legislation. Human-Centred Design principles guide social entrepreneurs in partnering with communities to develop technological solutions (Singh, 2015). At the macro-level, Social Wealth Economic Indicators measure the benefit of a partnership system for an entire nation (Ghosh, 2015).

Each of the above theories is highly insightful and relevant, but only within the mandated situation. The average person could rightly claim that none provides generic guidance, relevant to everyday problems. Presented next is a *complex*, yet internally-consistent theory describing *general* group behaviour from which *accurate* guidelines can be drawn. It is intended to operate at the micro-level, in accompaniment with HPT at the macro-level.

### **EUCRM, a theory of the group**

This paper advances the Encapsulated, Unified, Collaboration Research Model [EUCRM] that *encapsulates* social psychology research within a single, *unified* framework. EUCRM has five components, each experienced by *every* member of *any* group. These components are confidence, respect, communication, liking, and performance. See Figure 1.

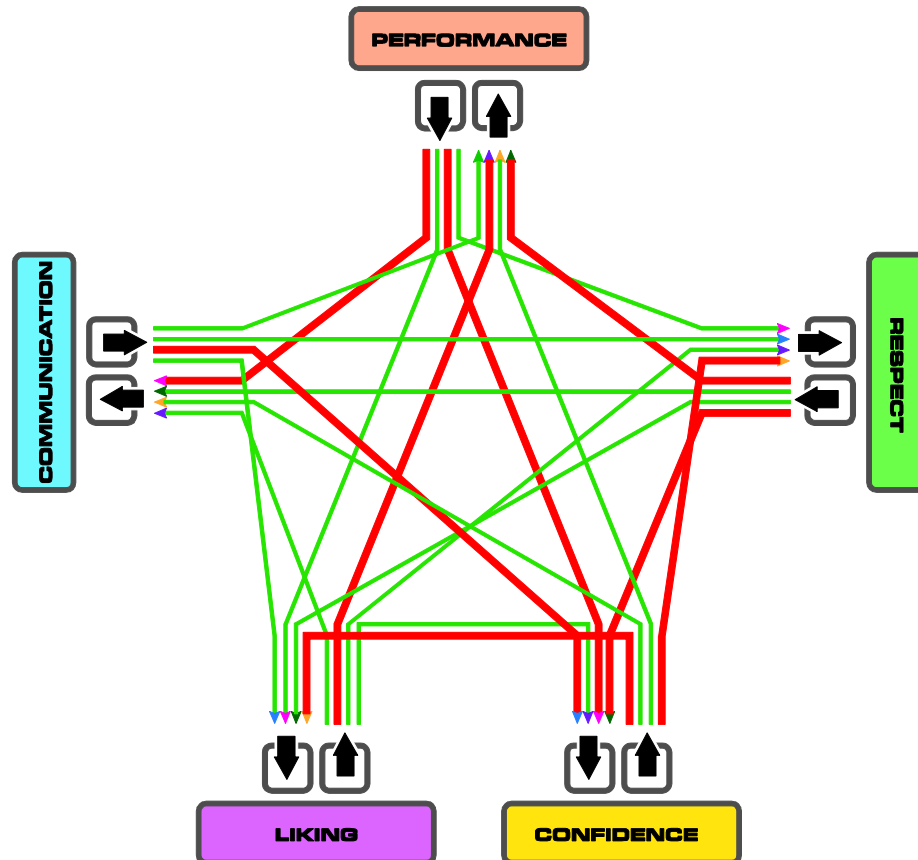

Figure 1. EUCRM framework. Red lines = opposing impact, Green lines = attracting impact

*Confidence* is a group member's willingness to suggest change, either for the group or for specific members. Since challenging the status quo is always a personal risk, confidence is similar to psychological safety, "a shared belief held by members of a team that the team is safe for interpersonal risk taking" (Edmondson, 1999, p. 354). While influenced by the group's environment, confidence is also strongly affected by personality, such as extroversion and need-for-achievement (Bligh, Pearce, & Kohles, 2006; Miller, Droge, & Toulouse, 1988).

*Respect* between group members is commonly acknowledged as desirable. The respect component includes appreciating another's abilities, preferences and opinions. To appreciate something requires understanding, thus making empathy a predictor of respect. Respect also may apply to the group's culture and norms, which aggregate past group members' contributions and preferences.

The aim of intragroup *communication* is to coordinate member activity. *Teaching* and *cooperation* are two methods that achieve peer-to-peer coordination. Cooperation achieves coordination through joint effort on a task. If knowledge is *also* transferred to the recipient via teaching, coordination can become ongoing.

*Liking* is your *perception* of the warmth and regard that others hold for you. A similar construct is *interpersonal attraction*, or “a shared liking for, or attachment to, the members of the group” (Beal, Cohen, Burke, & McLendon, 2003, p. 995). Liking is critical for developing trust between members, and for a leader’s influence (Sitkin, Lind, & Siang, 2009). Reputation is a summation of liking from the group towards individual members.

When members feel that the group is achieving its goals, *performance* is perceived to be high. People join a group for individual reasons, but when collaborating, goals are achieved collectively. A strong strategy, or availability of expertise and resources, can convince members that *future* performance will be high, and vice versa when these are absent.

## OUR INFLUENCE OVER COLLABORATION

Leadership is most associated with confidence, but ordinary group members also affect the group. EUCRM suggests this occurs primarily through communication. Choosing with whom, and what information, members communicate potentially makes an enormous difference to the group’s functioning.

Liking and respect are also within the members’ control, limited respectively by their emotional intelligence and their ability to empathise. For example, liking may be adjusted through an optimistic or pessimistic bias that places greater emphasis on positive or negative interactions, respectively (Luthans & Youssef, 2007). Considering respect, members can choose to give particular colleagues greater or lesser respect.

Performance and confidence are less under members' control. The success of group outcomes is a collective responsibility. As mentioned, confidence is influenced by psychological safety and members' personalities, but also individual status and authority (Mathieu, Maynard, Rapp, & Gilson, 2008).

Overall group confidence can be influenced by the steepness of the hierarchy. A member's capacity to enact change requires her or him to be delegated power. Delegation can take the form of permanent promotion or a temporary assignment. Egalitarian structures provide less clear means of delegation, potentially reducing confidence.

For example, low confidence may explain the violence that occurs in egalitarian tribes (Leary, Twenge, & Quinlivan, 2006). We might imagine the frustration arising as a result of suggestions not voiced. In a modern example of egalitarianism, improved access open plan offices is outweighed by noise and loss of privacy (Kim & de Dear, 2013). Less differentiation between individuals' space reduces both time for reflection, and self-expression, and therefore confidence.

According to HPT, at the macro level, delegation is optimum when in *hierarchies of actualisation* (R. Eisler, 2015a). These occur when leaders delegate with the interests of their subordinates in mind, rather than only themselves - for example, giving subordinates opportunities to advance their careers.

Respect is also influenced by a group's hierarchy. When the hierarchy is steep, individual competence and preferences become less important than who has power. Low respect has accompanying disrespect for norms, which results in the *tragedy of the commons* (Milinski, Semmann, & Krambeck, 2002). This occurs when people follow self-interest in extracting a resource, leading to over-exploitation. Ignoring the group's interests shows low respect, and is enabled by a steep hierarchy. A desire to climb the hierarchy encourages people to strive for personal, rather than collective, benefit (Zitek & Jordan, 2016).

Conversely, in a shallow hierarchy, peer pressure is more influential than management approval. Due to threat of peer punishment, respect for group norms is also increased (Mani, Rahwan, & Pentland, 2013). In terms of tragedy of the commons, when our peers notice us taking an exorbitant share of the communal asset, repercussions will follow. Thus, a shallow hierarchy fosters mutual respect, but reduces member confidence.

### **Micro behaviour of EUCRM: group strategy change**

EUCRM components describe the state of the system, which in this case is a collaborating group. Interaction between the components describes its dynamics, or how the system changes over time. Dynamics allow cause-effect prediction, and from it, guidelines can be drawn.

For EUCRM, dynamics are defined through impacts. Impacts are substantiated by social psychological theory, and/or reinterpreting the results of published findings. Defining all twenty impacts goes beyond the scope of this article; detailed information is available at [www.eucrm.net.au](http://www.eucrm.net.au).

Each impact leaves the output of the *impactor* component, and enters the input of the *impactee* component (Figure 1).

- A (thin) green line is an attracting impact. An impactor forces an impactee *into* alignment with its level.
- A (thick) red line is an opposing impact. An impactor forces an impactee *out of* alignment with its level.

Further explanation of opposing and attracting impacts is at [eucrm.net.au/badges](http://eucrm.net.au/badges).

EUCRM can be used to generate awareness of individual behaviour within groups. An example is a change to group strategy prompted by some kind of collective failure, such as a business losing market share or a sports team losing a game.

- Initially, group members perceive a drop in group performance (performance ↓).
- The first response is then thinking about what can be done differently to improve performance (performance ↓ → confidence ↑).



- The second response is putting forward ideas to their colleagues for discussion (confidence  $\uparrow$   $\rightarrow$  communication  $\uparrow$ ).
- Motivated by the dire situation, the third response is listening to those ideas (performance  $\downarrow$   $\rightarrow$  communication  $\uparrow$ ).
- The fourth step is becoming motivated towards a strategy that people had input into, and therefore feel ownership of (confidence  $\uparrow$   $\rightarrow$  performance  $\uparrow$ ).
- The fifth response is implementing the strategy, which, because everyone has been involved in the discussion, will be well understood and coordinated (communication  $\uparrow$   $\rightarrow$  performance  $\uparrow$ ).

This demonstrates how EUCRM can be used to capture micro-level dynamics, and therefore supply guidelines for individual behaviour of, in this case, strategy change (Figure 2).

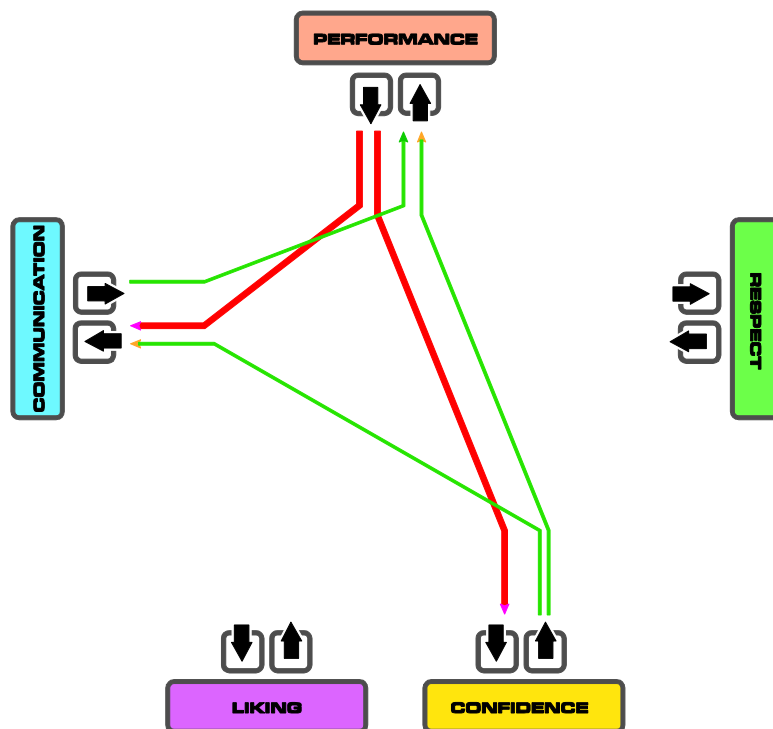

Figure 2. Impacts involved in group strategy change

### Macro behaviour of EUCRM: feedback

To allow contiguous transition from macro- to micro-level, EUCRM also needs to demonstrate consistency with HPT's macro-level ideas. The effect of hierarchy and

leadership has been discussed, but these act on specific components. It is also important to demonstrate that EUCRM dynamically behaves in ways consistent with HPT.

This is achieved through considering feedback, a powerful influence on any system. Each pair of components has two parallel impacts, travelling in opposite directions. Feedback occurs when the impacts operate in tandem (Forrester, 1994). There are three possible types of feedback and accompanying behaviours (Figure 3).

Impact A → B	Impact B → A	Feedback Type	Behaviour
Attracting	Attracting	Positive reinforcing	Both components either high or low in tandem, then remain there.
Attracting	Opposing	Stabilising	Components oscillate around their original positions
Opposing	Attracting		
Opposing	Opposing	Negative reinforcing	One component driven high, one low, then remain there.

Figure 3: Feedback types

Positive reinforcing feedback links communication, respect, and liking (Figure 4). They operate in tandem, and tend to rise or fall as one. All three also feature as themes in HPT literature, suggesting they form the basis of the partnership system. This is consistent with egalitarianism, which HPT favours, supporting respect (Eisler, 1987). Thus, any collaboration remains intact through the trio of communication, liking, and respect.

Confidence is fostered most easily within a steep hierarchy. Confidence has positive reinforcing feedback with performance, and stabilising feedback with communication and liking, but negative reinforcing feedback with respect. This implies that respect and confidence tend to be mutually opposing. Notice that there is only one negative reinforcing feedback, since all other opposing impacts are matched with an attracting impact (Figure 5).

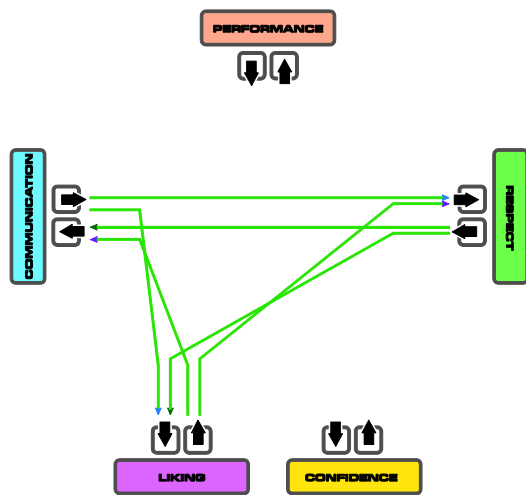

Figure 4: Positive reinforcing feedback between trio of components

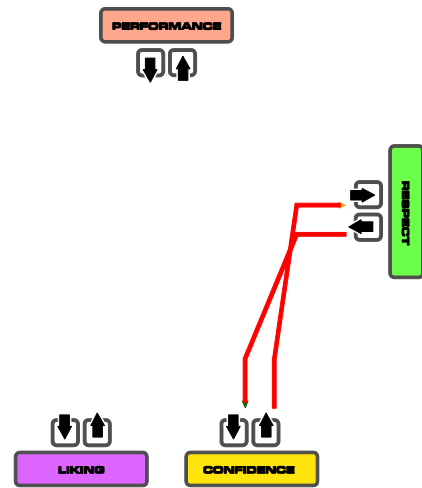

Figure 5: Negative reinforcing feedback between respect and confidence (bolded red)

Confidence allows the group to adapt to challenges, and therefore is a potential explanation for group-level evolution described above in the context of prevalence of psychopathy, and also by the field of sociobiology (Wilson & Wilson, 2007). This may explain why evolution has preserved groups' ability to innovate, in the form of confidence, and in its extreme form, psychopathy. It must however be balanced against maintaining collaboration health, and treating one another well, preserving the trio.

This analysis suggests that in promoting both collaborative health and innovation, leaders should seek a balance between confidence and the triumvirate. Doing so may require adjustment of hierarchy steepness. Depending upon whether innovation would be beneficial, confidence may not actually be desirable.

In some contexts, especially those that are process-based, lack of confidence to enact change is preferable. In some situations, innovation is not welcome, but in other situations it is. For example, a government regulator would wish that procedures are followed, but a start-up company expects its people to innovate.

In other less well-defined contexts, innovation and process occur in parallel. Hospitals, schools, and academic research are environments in which confidence should be selectively exhibited. Novel problems are confronted, but following established protocols and rules remains important.

### **Teaching guidelines, and testing the effect**

Evidence for theory supporting *zero-sum* behaviours has been found in both the laboratory (Haslam, 2004) and wider society (Waldron, 1998). Finding evidence supporting *positive-sum* theory within social psychology has been a source of frustration (Dashtipour, 2015). In response, entire branches of social psychology have rejected empiricism in theory building, instead preferring narrative approaches (admittedly, contradicting the scientific principle).

Empirically testing a complex theory can be difficult, but SIT shows that teaching people about their xenophobic instincts enables better regulation of those instincts. For instance, the 'Green Circle' program asks children to draw a circle around their friends and family, then gradually expand it to include more types of people (Houlette et al., 2004). EUCRM can follow a similar approach by teaching its framework, and then looking for a resulting change in the student's behaviour.

### **CONCLUSION**

SIT, evolution, and economics are founded upon our selfish, *zero-sum* desires (Brewer & Gardner, 1996). On the other hand, HPT is a powerful message around human rights and equality. EUCRM encompasses both our selfish desires and an aspiration for collective endeavour. By demonstrating that collaboration is constituted by both selfish and collective instincts, EUCRM can realistically guide the behaviour of group members.

For all but the powerful, living within a domination system is generally less pleasant than a partnership system. Continuing, widespread support for *zero-sum* policies that promote wealth inequality and tribalism might be explained by public ignorance of *positive-sum* behaviours.

Perhaps, once this ignorance is alleviated, people will demand a different approach from their politicians. Educating the public about HPT in concert with EUCRM may give rise to a zeitgeist of public pressure for our leaders to either reform our societies' institutions, or make way for those who can.

## References

- Ajzen, I. (1991). The theory of planned behavior. *Organizational Behavior & Human Decision Processes*, 50, 179-211. [http://doi.org/10.1016/0749-5978\(91\)90020-T](http://doi.org/10.1016/0749-5978(91)90020-T)
- Alestalo, M., & Kuhnle, S. (1987). The Scandinavian Route: Economic, Social, and Political Developments in Denmark, Finland, Norway, and Sweden. *International Journal of Sociology*, 16(3/4), 3-38.
- Amodio, D. M., Jost, J. T., Master, S. L., & Yee, C. M. (2007). Neurocognitive correlates of liberalism and conservatism. *Nature Neuroscience*, 10(10), 1246-1247.
- Baysinger, M. a, Scherer, K. T., & LeBreton, J. M. (2014). Exploring the disruptive effects of psychopathy and aggression on group processes and group effectiveness. *The Journal of Applied Psychology*, 99(1), 48-65.
- Beal, D. J., Cohen, R. R., Burke, M. J., & McLendon, C. L. (2003). Cohesion and performance in groups: a meta-analytic clarification of construct relations. *The Journal of Applied Psychology*, 88(6), 989-1004. <http://doi.org/10.1037/0021-9010.88.6.989>
- Bligh, M. C., Pearce, C. L., & Kohles, J. C. (2006). The importance of self- and shared leadership in team based knowledge work: A meso-level model of leadership dynamics. *Journal of Managerial Psychology*, 21, 296-318. <http://doi.org/10.1108/02683940610663105>
- Boddy, C. (2010). Leaders without ethics in global business: Corporate psychopaths. *Journal of Public Affairs*, 138(June), 121-138. <http://doi.org/10.1002/pa>
- Boehm, C., Barclay, H. B., Dentan, R. K., Dupre, M., Hill, J. D., Kent, S., ... Rayner, S. (1993). Egalitarian Behavior and Reverse Dominance. *Current Anthropology*, 34(3), 227-254. Retrieved from <http://www.jstor.org/stable/2743665>
- Boothby, N., Crawford, J., & Halperin, J. (2006). Mozambique child soldier life outcome study: lessons learned in rehabilitation and reintegration efforts. *Global Public Health*, 1(1), 87-107.
- Brewer, M. B., & Gardner, W. (1996). Who is this "We"? Levels of collective identity and self representations. *Journal of Personality and Social Psychology*, 71(1), 83-93.
- Brosnan, S. F., & Hopper, L. M. (2014). Psychological limits on animal innovation. *Animal Behaviour*, 92(JUNE), 325-332. <http://doi.org/10.1016/j.anbehav.2014.02.026>
- Caruso, H. M., & Woolley, A. W. (2008). Diversity and Groups: Harnessing the power of emergent interdependence to promote diverse team collaboration. *Diversity and Groups*, 11, 245-266. Retrieved from [http://dx.doi.org/10.1016/S1534-0856\(08\)11011-8](http://dx.doi.org/10.1016/S1534-0856(08)11011-8)
- Castells, M. (2010). *The power of identity. The Information Age Economy Society and Culture* (2nd ed., Vol. 2). West Sussex, UK: Wiley-Blackwell.

- Clark, D. K., & Rakestraw, R. V. (1995). *Readings in Christian Ethics: Issues and Applications* (Vol. 2). Grand Rapids, MI: Baker Academic.
- Cook, J., & Lewandowsky, S. (2011). *The debunking handbook*. St. Lucia, Australia. Retrieved from <http://sks.to/debunk>
- Dashtipour, P. (2015). Social Psychology: A commentary on organizational research. In I. Parker (Ed.), *Handbook of Critical Psychology*. London and New York: Routledge.
- De Botton, A. (2000). *The consolations of philosophy*. New York: Vintage Books.
- Doran, K. M., McCormack, R. P., Johns, E. L., Carr, B. G., Smith, S. W., Goldfrank, L. R., & Lee, D. C. (2016). Emergency Department Visits for Homelessness or Inadequate Housing in New York City before and after Hurricane Sandy. *Journal of Urban Health: Bulletin of the New York Academy of Medicine*, 93(2), 331-344. <http://doi.org/doi:10.1007/s11524-016-0035-z>
- Drew, A. J., & Kriz, A. P. (2012). Towards a Theoretical Framework for Examining Societal-Level Institutional Change. *Advances in International Management*, 25(2012), 65-98.
- Edmondson, A. (1999). Psychological safety and learning behavior in work teams. *Administrative Science Quarterly*, 44(2), 350-383. Retrieved from <http://www.jstor.org/stable/2666999>
- Eisler, B. R., Dolan, S. L., & Raich, M. (2013). Leading Towards Change of Ethics and Caring: Resisting Temptation and Reaping the Benefit. *The European Business Review*, 51-54. Retrieved from [www.europeanbusinessreview.com](http://www.europeanbusinessreview.com)
- Eisler, R. (1987). *The Chalice and the Blade*. San Francisco: Harper Collins.
- Eisler, R. (2015a). A Conversation with Peter Senge: Transforming Organizational Cultures. *International Journal of Partnership Studies*, 2(1), 0-14. Retrieved from <http://pubs.lib.umn.edu/ijps/vol2/iss1/2>
- Eisler, R. (2015b). Nurturing Children's Humanity: Partnership Education. *Interdisciplinary Journal of Partnership Studies*, 2(2), 0-33.
- Eisler, R. (2016). Whole systems change. *Executive Excellence*, 14(10), 6.
- Forrester, J. (1994). System dynamics, systems thinking, and soft OR. *System Dynamics Review*, 10(January), 245-256.
- Gao, Y., & Raine, A. (2010). Successful and unsuccessful psychopaths: A neurobiological model. *Behavioral Sciences & the Law*, 210(April), 194-210.
- Gervais, M. M., Kline, M., Ludmer, M., George, R., & Manson, J. H. (2013). The strategy of psychopathy: primary psychopathic traits predict defection on low-value relationships. *Proceedings of the Royal Society B: Biological Sciences*, (February).
- Ghosh, I. (2015). Social Wealth Economic Indicators for a Caring Economy. *International Journal of Partnership Studies*, 1(1), 0-76. Retrieved from <http://pubs.lib.umn.edu/ijps/vol1/iss1/5>
- Glenn, A. L., Kurzban, R., & Raine, A. (2011). Evolutionary theory and psychopathy. *Aggression and Violent Behavior*, 16(5), 371-380.
- Guo, J. (2015, December). The real reasons Donald Trump's so popular – for people totally confused by it. *The Washington Post*. Retrieved from <https://www.washingtonpost.com/news/wonk/wp/2015/12/12/the-four-basic-reasons-that-explain-why-donald-trump-actually-is-so-popular/>

- Haidt, J. (2001). The emotional dog and its rational tail: a social intuitionist approach to moral judgment. *Psychological Review*, 108, 814-834. Retrieved from [http://www.motherjones.com/files/emotional\\_dog\\_and\\_rational\\_tail.pdf](http://www.motherjones.com/files/emotional_dog_and_rational_tail.pdf)
- Haslam, S. A. (2004). *Psychology in organisations* (2nd ed.). London: Sage.
- Henrich, J., Boyd, R., Bowles, S., Camerer, C., Fehr, E., Gintis, H., ... Tracer, D. (2005). "Economic man" in cross-cultural perspective: behavioral experiments in 15 small-scale societies. *The Behavioral and Brain Sciences*, 28(6), 795-815-55.
- Hogg, M., & Turner, J. (1985). Interpersonal attraction, social identification and psychological group formation. *European Journal of Social Psychology*, 15(January 1984), 51-66.
- Houlette, M. A., Gaertner, S. L., Johnson, K. M., Banker, B. S., Riek, B. M., & Dovidio, J. F. (2004). Developing a More Inclusive Social Identity: An Elementary School Intervention. *Journal of Social Issues*, 60(1), 35-55.
- Johnson, D. W., & Johnson, R. T. (2014). Cooperative Learning in 21st Century. *Anales De Psicología*, 30, 841-851. <http://doi.org/10.6018/analesps.30.3.201241>
- Jost, J. T., Glaser, J., Kruglanski, A. W., & Sulloway, F. J. (2003). Political conservatism as motivated social cognition. *Psychological Bulletin*, 129(3), 339-375. <http://doi.org/10.1037/0033-2909.129.3.339>
- Khan, S. (2016). When does equality flourish? *New Yorker*. Retrieved from <http://www.newyorker.com/tech/elements/when-does-equality-flourish>
- Kiehl, K. a. (2006). A cognitive neuroscience perspective on psychopathy: evidence for paralimbic system dysfunction. *Psychiatry Research*, 142(2-3), 107-28.
- Kim, J., & de Dear, R. (2013). Workspace satisfaction: The privacy-communication trade-off in open-plan offices. *Journal of Environmental Psychology*, 36, 18-26. <http://doi.org/10.1016/j.jenvp.2013.06.007>
- Koeslag, J. H. (1997). Sex, the Prisoner's Dilemma Game, and the evolutionary inevitability of cooperation. *Journal of Theoretical Biology*, 189(1), 53-61. <http://doi.org/10.1006/jtbi.1997.0496>
- Leary, M., Twenge, J., & Quinlivan, E. (2006). Interpersonal rejection as a determinant of anger and aggression. *Personality and Social Psychology Review*, 10.
- Luthans, F., & Youssef, C. M. (2007). Emerging Positive Organizational Behavior. *Journal of Management*, 33(3), 321-349. <http://doi.org/10.1177/0149206307300814>
- Maner, J. K., & Mead, N. L. (2010). The essential tension between leadership and power: when leaders sacrifice group goals for the sake of self-interest. *Journal of Personality and Social Psychology*, 99(3), 482-97.
- Mani, A., Rahwan, I., & Pentland, A. (2013). Inducing peer pressure to promote cooperation. *Scientific Reports*, 3, 1735.
- Manz, C. C. (1986). Self-leadership: toward an expanded theory of self-influence processes in organizations. *Academy of Management Review*, 11(3), 585-600. <http://doi.org/10.5465/AMR.1986.4306232>
- Mathieu, J., Maynard, M. T., Rapp, T., & Gilson, L. (2008). Team Effectiveness 1997-2007: A Review of

- Recent Advancements and a Glimpse Into the Future. *Journal of Management*, 34(3), 410-476.
- McElwee, S. (2015, June). Welcome to feudalism, America: How the 1 percent is systematically destroying the middle class. *Salon*. Retrieved from [http://www.salon.com/2015/06/01/welcome\\_to\\_feudalism\\_america\\_how\\_the\\_1\\_percent\\_is\\_systematically\\_destroying\\_the\\_middle\\_class/](http://www.salon.com/2015/06/01/welcome_to_feudalism_america_how_the_1_percent_is_systematically_destroying_the_middle_class/)
- Mealey, L. (1995). The sociobiology of sociopathy: An integrated evolutionary model. *Behavioral and Brain Sciences*, 18(1995), 1-37.
- Merton, R. K. (1968). *Social Theory and Social Structure*. New York: The Free Press.
- Milinski, M., Semmann, D., & Krambeck, H.-J. (2002). Reputation helps solve the “tragedy of the commons.” *Nature*, 415(6870), 424-426.
- Miller, D., Droge, C., & Toulouse, J.-M. (1988). Strategic process and content as mediators between organizational context and structure. *Academy of Management Journal*.
- Mink, C. (2015). It’s About the Group, Not God: Social Causes and Cures for Terrorism. *Journal for Deradicalization*, (5), 63-91.
- North, D., Wallis, J., & Weingast, B. (2009). *Violence and Social Orders: A Conceptual Framework For Interpreting Recorded Human History*. New York: Cambridge University Press.
- Parker, M. (2016, June). Why we shouldn’t dismiss Bilderberg conspiracies so lightly. *The Conversation*. Retrieved from <https://theconversation.com/why-we-shouldnt-dismiss-bilderberg-conspiracies-so-lightly-60653>
- Pasalich, D. S., Dadds, M. R., Hawes, D. J., & Brennan, J. (2012). Attachment and callous-unemotional traits in children with early-onset conduct problems. *Journal of Child Psychology and Psychiatry, and Allied Disciplines*, 53(8), 838-45.
- Pierce, B., & White, R. (1999). The evolution of social structure: Why biology matters. *Academy of Management Review*, 24(4), 843-853.
- Potter, T. M. (2015). Partnership-Based Health Care: Suggestions for Effective Application. *International Journal of Partnership Studies*, 1(1), 0-13. Retrieved from <http://pubs.lib.umn.edu/ijps/vol1/iss1/8>
- Poynting, S., & Donaldson, M. (2005). Snakes and Leaders: Hegemonic Masculinity in Ruling-Class Boys’ Boarding Schools. *Men and Masculinities*, 7(4), 325-346.
- Pratt, R. (2014). A Therapeutic Treatment Model For Sexually Abusive Behaviours in Victoria Australia: What Does Treatment Look Like? *Sexual Abuse in Australia and New Zealand*, 6(November), 20-30.
- Reidy, D. E., Kearns, M. C., & DeGue, S. (2013). Reducing Psychopathic Violence: A Review of the Treatment Literature. *Aggression and Violent Behavior*, 18(5), 527-538. <http://doi.org/10.1017/CBO9781107415324.004>
- Rittel, H. W. J., & Webber, M. M. (1973). Dilemmas in a general theory of planning. *Policy Sciences*, 4(2), 155-169.
- Rosen, A. (2014, December). We Now Have A Much Better Idea Of How The ISIS “Caliphate” Operates. *Business Insider, Australia*. Retrieved from <http://www.businessinsider.com.au/how-the-isis-caliphate-operates-2014-12>
- Roy, L., Crocker, A. G., Nicholls, T. L., Latimer, E. A., & Reyes-Ayllon, A. (2014). Criminal Behavior and



- Victimization Among Homeless Individuals With Severe Mental Illness: A Systematic Review. *Psychiatric Services*, 65(6), 739-750.
- Ruthven, M. (2012). Fundamentalism and Other Obstacles. *Universal Rights in a World of Diversity. The Case of Religious Freedom*, 456-474.
- Shoemaker, P., Tankard, J. W., & Lasorsa, D. L. (2004). *How to build social science theories*. Thousand Oaks, California: Sage.
- Sitkin, S. B., Lind, E. A., & Siang, S. (2009). The six domains of leadership. *Leader to Leader*, 2006(S1), 27-33. <http://doi.org/10.1002/ltl.350>
- Smith, W. (2014, December). Why the federal budget is not like a household budget. *The Conversation*. Retrieved from <https://theconversation.com/why-the-federal-budget-is-not-like-a-household-budget-35498>
- Snegovaya, M. (2015, December). The Implications of Russia's Mafia State. *The American Interest*. Retrieved from <http://www.the-american-interest.com/2015/12/23/the-implications-of-russias-mafia-state/>
- Stokke, K., & Törnquist, O. (2013). The Relevance of the Scandinavian Experiences. In *Democratization in the Global South* (pp. 21-41). Palgrave Macmillan UK. Retrieved from <http://folk.uio.no/ollet/files/TransformativeTwo.pdf>
- Tajfel, H. (1982). Social psychology of intergroup relations. *Annual Review of Psychology*, 1-39.
- Thorngate, W. (1976). Possible limits on a science of social behavior. In J. H. Strickland, F. E. Aboud, & K. J. Gergen (Eds.), *Social psychology in transition* (pp. 121-139). New York: Plenum.
- Uphoff, N., & Krishna, A. (2004). Civil society and public sector institutions: More than a zero-sum relationship. *Public Administration and Development*, 24(4), 357-372.
- Waldron, D. (1998). Status in organizations: Where evolutionary theory ranks. *Managerial and Decision Economics*, 19(7), 505-520. Retrieved from <http://www.jstor.org/stable/3108129>
- Warren, M. E., & Gastil, J. (2015). Can Deliberative Minipublics Address the Cognitive Challenges of Democratic Citizenship? *Journal of Politics*, 77(2), 562-574.
- West, A. (Presenter), Gawley, N. E. (Producer), & Jeffes, J. (Executive P. (2016). Why are evangelical Christians supporting Donald Trump? Australia: ABC Radio National, Religion and Ethics Report. Retrieved from <http://www.abc.net.au/radionational/programs/religionandethicsreport/why-are-evangelical-christians-supporting-donald-trump/7383170>
- Wilson, D. S., & Wilson, E. O. (2007). Rethinking the Theoretical Foundation of Sociobiology. *Quarterly Review of Biology*, 82(4), 1-57.
- Wong, S. C. P., & Olver, M. E. (2015). Risk reduction treatment of psychopathy and applications to mentally disordered offenders. *CNS Spectrums*, 20(3), 303-310. <http://doi.org/10.1017/S1092852915000322>
- Yeager, D. S., & Walton, G. M. (2011). Social-Psychological Interventions in Education: They're Not Magic. *Review of Educational Research*, 81(2), 267-301.
- Zelin, A. Y. (2014). The ISIS guide to building an Islamic State. *The Washington Institute*. Retrieved from <http://www.washingtoninstitute.org/policy-analysis/view/the-isis-guide-to-building-an-islamic-state>

Zitek, E., & Jordan, A. (2016, July 16). Narcissists Don't Like Flat Organizations. *Harvard Business Review*. Retrieved from <https://hbr.org/2016/07/research-narcissists-dont-like-flat-organizations>

---

Benjamin Heslop, MPhil, BEng (Systems) is a PhD candidate in the field of social psychology at the University of Newcastle, Australia. He has earned a Masters of Philosophy examining entrepreneurial collaboration, and a Bachelor of Engineering, both at The Australian National University. Mr Heslop is investigating collaboration using engineering systems modelling. His research hopes to combine significant aspects of existing social psychology theory into a single framework.

Faculty of Health and Medicine, University of Newcastle

Tel: +61 2 4042 0345

Email: [benjamin.heslop@uon.edu.au](mailto:benjamin.heslop@uon.edu.au)

Kylie Bailey, PhD, B.A. (Psych) M.Psych Clin, PhD (Psychiatry), is a senior clinical psychologist who has over 20 years clinical experience. Kylie's expertise is with addiction, childhood trauma, self-harm and posttraumatic stress disorder, and she is also currently conducting research on combined depression, alcohol and posttraumatic stress disorder in adults. Kylie also teaches postgraduate addiction and mental health courses and is employed as a clinical manager.

Faculty of Health and Medicine, University of Newcastle

Tel: +61 2 4042 0541

Email: [kylie.bailey@newcastle.edu.au](mailto:kylie.bailey@newcastle.edu.au)

Jonathan Paul, PhD, BSc (Hons), credentials, is an emerging scientist within the field of reproductive medicine working toward the development of novel strategies for clinical intervention in major obstetric complications. As a scientist developing projects focused toward clinical translation and academic collaboration, Dr. Paul has a practical interest in mechanisms that underpin effective collaboration, but also seeks to contribute to this important research topic.

Faculty of Health and Medicine, University of Newcastle

Tel: +61 2 4042 0348

Email: [jonathan.paul@newcastle.edu.au](mailto:jonathan.paul@newcastle.edu.au)

Antony Drew, PhD (Management), MBA (Merit), has spent the past 10 years developing a theoretical framework, drawing from a number of disciplines, to explain how co-operative and collaborative behaviours evolve over time in different socio-cultural and socio-political contexts, and why. His research into co-operative and collaborative behaviour has been internationally published and presented.

Faculty of Business and Law, University of Newcastle

Tel: +61 2 492102099

Email: [antony.drew@newcastle.edu.au](mailto:antony.drew@newcastle.edu.au)

Laureate Professor Roger Smith, MBBS, PhD, is Co-Director of the University of Newcastle's Priority Research Centre for Reproductive Science, the Director of the University's Mothers and Babies Research Centre, and also of the Department of Endocrinology at the John Hunter Hospital. A self-described 'specialised zoologist,' Prof. Smith has an interest in the social determinants of human behaviour especially as it affects health and education.

Faculty of Health and Medicine, University of Newcastle

Tel: +61 2 4041 4376

Email: [roger.smith@newcastle.edu.au](mailto:roger.smith@newcastle.edu.au)