

Western Oregon University
Digital Commons@WOU

History of the Book: Disrupting Society from
Tablet to Tablet

Student Scholarship

6-2015

Chapter 01 - The History of Early Materials

Alyssa Adams

Western Oregon University, aadams12@wou.edu

Follow this and additional works at: https://digitalcommons.wou.edu/history_of_book

 Part of the [Cultural History Commons](#), and the [History of Science, Technology, and Medicine Commons](#)

Recommended Citation

Adams, Alyssa. "The History of Early Materials." *Disrupting Society from Tablet to Tablet*. 2015. CC BY-NC

This is brought to you for free and open access by the Student Scholarship at Digital Commons@WOU. It has been accepted for inclusion in History of the Book: Disrupting Society from Tablet to Tablet by an authorized administrator of Digital Commons@WOU. For more information, please contact digitalcommons@wou.edu.

The History of Early Materials

-Alyssa Adams-

From the time that man discovered how to draw on cave walls, human interest in recording information and events flourished. Cities were built, societies and civilizations were born, and the world as we know it was forever changed. While writing began as symbols and drawings, it soon blossomed into multiple languages with a variety of mediums such as clay tablets, papyrus, silk and paper on which to record information.

Clay Tablets

In Mesopotamia circa 3500 B.C. an ancient tribe known as the Sumerians found a source of wonder. Clay was found in the nearby rivers which could be molded into pots, urns, and also into writing tablets. While still wet, these tablets were drawn on in the first form of writing called cuneiform¹. Cuneiform was quite similar to cave drawings at the beginning; both forms of inscribing used pictorial representations of items, weather, and even emotions. The difference was that people began recording their information with a writing implement on things besides walls, such as indenting designs into wet clay. When the clay was baked in the sun, it became somewhat hardened; however, by soaking the tablet in water and smoothing it out, the tablet could be reused. By using this technique, the clay tablet became a multiple use tool, which replaced most cave writings. Only when fired in a kiln or left in a burning house did these tablets become hardened and their information permanently etched into the tablet's face.

Such writings as *The Epic of Gilgamesh* were written on clay tablets in cuneiform.

Major civilizations including the Akkadians, Babylonians, and Sumerians used clay tablets and cuneiform in their daily life in Mesopotamia, now known as the Middle East¹. Scribes often used these tablets to keep inventory of historic events such as droughts, a bountiful harvest, or a new leader. Although cuneiform was used by officials, common folk also used

pictures on clay tablets as a means to tell stories and keep record of items they had². Literacy in these ancient societies was rare³. Those that had the knowledge to distinguish the meaning of the cuneiform belonged to the elite few and held most of the power in these groups. Because of this, anyone who had the advantage of literacy could control the general public.

While not known as a disruptive innovation, since there was no material it displaced, clay tablets paved the way for written technology. When clay was found to be a useful medium for writing and drawing, civilizations were able to flourish and expand. Government systems had the means to record information and even civilians could identify items with just a simple design in clay as a tag². In some areas, valuable items would be placed in clay jars and a design was inscribed in the hardening clay. This was used to identify the contents. Stories that were once told by mouth could now be inscribed on clay tablets, while religious writings spoke of gods and their need for sacrifices or offerings³. Priests were able to collect taxes and because they could “read” what the gods were inscribing to them, most people just followed their rules. These religious leaders were able to keep a better record of the taxes owed and who was loyal⁴. Being able to permanently record information led to more advanced cultures and a more refined system of governing.

Although clay tablets were the break-through for systems of recording, there were problems that arose. Clay tablets were often heavy and fragile if dropped, even though they were some of the most durable mediums. Transporting these tablets could be cumbersome and while they were used in the form of letters, they were not as convenient as what was yet to come.

Papyrus to Bamboo/Silk

Papyrus, most common in Egypt, was used in 2500 B.C. as the first paper-like medium to write upon. Strips of the reed were laid out in two layers at right angles from each other and pressed together to create sheets. Because of

how it was made, one side of the sheet had horizontal lines while the other had vertical lines⁵.

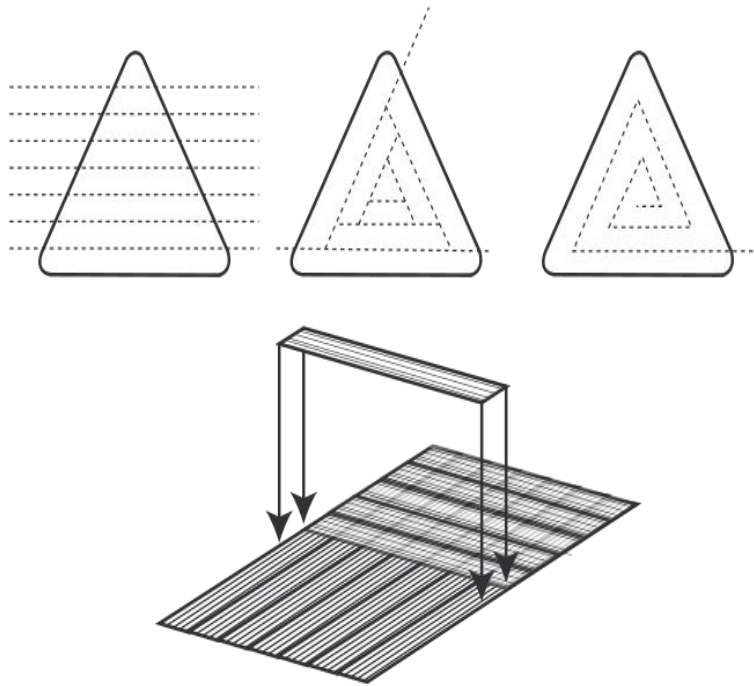

Different ways of cutting papyrus stem and the making of a papyrus sheet¹

This material while quite rot-resistant, because it was made of cellulose, was susceptible to mold when introduced to wetter climates. Many centuries passed before other civilizations around Egypt began to use different materials for their writings.

Around 600 B.C. in the far east of China, bamboo stalks that were cut in half and woven together with string began to be used for written record keeping. According to some sources, bamboo slips were used as early as 1250 B.C. in the Shang period⁶, although no artifacts have survived. By 400 B.C., China began transitioning from bamboo slips to silk sheets as their main medium for writing. Silk was much more expensive than bamboo and more important documents were first written upon bamboo and then rewritten onto

the silk. Both of these mediums were in great demand in the western countries, and so began the Silk Route connecting the East to the West.

Papyrus did not have as many trade routes throughout the east because it was used mostly in Egypt and surrounding countries. Their dry, warm climate was perfect for the moisture-susceptible medium⁷. Greece and Rome were among the nearby countries that had papyrus imported from Egypt. These countries used papyrus for official documents, book keeping, stories, and other writings. Although papyrus was a main source of income for Egypt, not many people had access to the material. This was due to the lack of literacy and resources available in many civilizations. Once again, people of high rank in office or of religious background were trained in the art of reading and writing. It was not common for people in Greek or Roman society to own papyrus for their own personal use unless they were extremely rich.

As a result of the Silk Route, many countries now had access to the prized possessions from China. Silk and bamboo items became a main desire for those who could afford the prices, and spread from India and Egypt all the way to Europe!

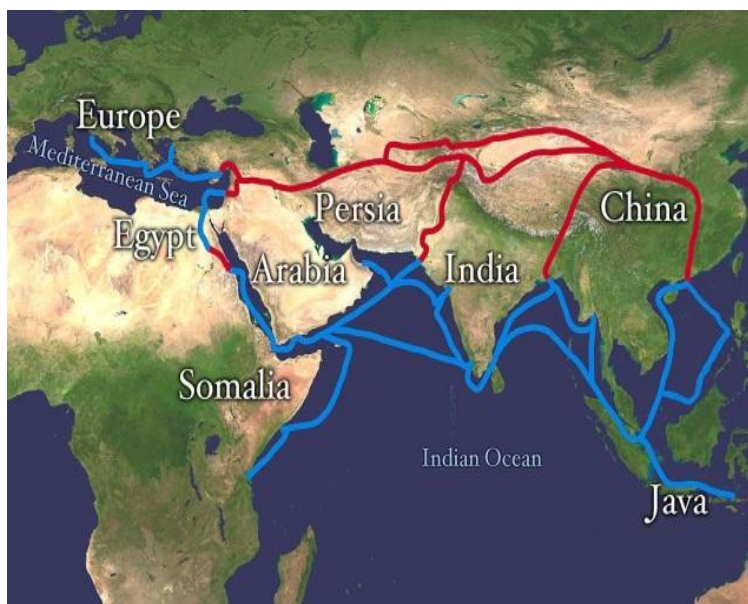

“Silk Route”

Here are major countries that were affected by the trading route².

Cities like Baghdad, Calcutta, and Xian were major hotspots for the boom in trading. Xian itself was one of the world's largest cosmopolitan (multicultural) cities⁸. These cities thrived because of the desire for many products, including bamboo and silk.

Papyrus made carrying writing materials much easier. Instead of carrying tablets that were large and bulky, people could carry papyrus rolled up in bundles allowing more information to be transported⁹. The papyrus was also able to be used with ink or charcoal instead of being carved into like the clay tablets. Multiple sheets could be made and stored at one time, before being written on, whereas clay tablets were made at the time that writing occurred. These sheets were also pasted together and made into a scroll form⁷. The beginnings of colleges and libraries occurred in the time when papyrus was gaining popularity. The library of Alexandria was known to have over 500,000 scrolls alone; imagine trying to store that many clay tablets!

Bamboo and silk also played key roles in creating a larger market throughout the eastern world. It is not known whether Chinese merchants actually travelled all the way to Europe to sell their goods. Many of these early salesmen would sell to other merchants and the goods would then be distributed around the known world. Along with the distribution of goods, societies along the trade routes flourished with the variety of people and possessions that passed through¹⁰. Disease was commonly carried along these routes, as was religion. Buddhism was propelled into popularity during this time period. Scrolls were of large importance to the Buddhist nature, as were wooden and clay tablets. Writing out scripture was known to be an art form, and monks practiced religiously to produce beautiful handwritten texts. Although most of the works were memorized, variations appeared in writings because of the backlash on religion. Some of the variations had false ideas for the Buddhist religion that were written by people of different faith. Christian colonizers and communist revolutionaries both destroyed many of the Buddhist texts over the

Ancient writing often went right-to-left and then left-to-right, like plows on a field.

years³. Because of this, the texts were continuously revived with multiple recopies.

Papyrus was the first paper-like material created and it had similar problems surrounding the use of paper in today's society. Moist climates wreaked havoc on papyrus and if not made properly, the sheets could fall apart or tear easily⁵. There was not a high demand for the newly created material in Egypt and because of this; it took a while for the popularity of papyrus to skyrocket. Although flexible and lightweight, bamboo was not as durable in wetter climates, whereas silk was more resilient³. Both of these mediums along with papyrus were much more portable and efficient than the clay tablet; however, they were prone to tearing, catching fire, and mildew damage.

Paper and Scrolls

Near 100 B.C. the future of writing was forever changed by the invention of paper-making in southeastern China. Fibers of cellulose were mashed in water until a mush formed and then it was collected on screens and dried before being used¹¹. These fibers were usually hemp waste that was unusable elsewhere. While paper technology spread across Asia, it would not reach Europe until after the 11th century. Once paper was introduced to Europe, a dramatic change arose that still exists today.

Many societies used paper in their official government duties. China originally started it and even societies in Egypt used paper; although they created it using different fibers. Europe also used paper; however, they used old rags to create their version¹². Sheets of paper were pasted together and hooked to wood pieces to create scrolls that were similar to papyrus scrolls, just more durable⁹. As with all new technologies, paper was quite expensive for many years. Literacy was also a problem when it came to who could use or want the paper. Men of color and all women were mostly illiterate in Europe. Men of power, high social standing, religious company, or wealth were the only ones

who owned paper. This group also made up most of the population who were considered literate, both in writing and reading.

Paper was originally used for wrapping items before people realized that the material was more durable than bamboo slips or silk sheets³.



“Chinese hemp paper” circa 100 B.C.³

Like bamboo, silk, and papyrus, paper was easier to transport than clay tablets, and was able to hold up better in moist climates. Because it was more durable, many sheets would be stitched or glued together and hooked onto a handle of wood, creating a scroll. A standard scroll was roughly 20 pages or about 5 meters long. Whether paper or papyrus was used as the medium, scrolls became the main information source before the invention of the codex⁹. When paper was finally introduced to Europe in the 11th century, its use grew exponentially. Information could now be written on this less expensive material than on parchment which was made of animal skins³. Paper was quite expensive early on, but advances were made to make it less costly, which caused a positive

disruption in these societies; eventually it resulted in what we know as paper today.

Although durable, paper was easy to tear and flammable. It was originally difficult to make, but as years progressed, better methods of paper making were invented. Rags in Europe were popular ingredients for paper; however, that did not cut the price of paper down until wood was found to be an adequate part of the paper-making process³. Scrolls were often a bit clumsy when being carried and difficult to read; one would have to unroll the whole piece to read a single line. This was difficult with lack of space; the invention of the codex helped fix problems that arose in the beginning of the paper era.

The Foundation of the Codex

From the use of cuneiform, to engraved symbols onto tablets, to the invention of paper used in scrolls, the various mediums used to write on have shaped the history of writing and recording as we know it. From this base point, the world continued to change with the invention of the codex, which would eventually replace the scroll.

References

1. Joshua Mark, "Cuneiform," Web (2011).
2. Wikipedia, "Clay Tablet," Web (n.d.)
3. Martyn Lyons, *Books: A Living History* (2011).
4. "Mesopotamia: The Rise of the First Civilization," Web (n.d.)
5. "Papyrus," R.B. Parkinson (1995).
6. History World, "History of Writing Materials," Web (n.d.)
7. Wikipedia, "Papyrus," Web (n.d.)
8. Frontiers of Travel, "The Great Silk Road Cities," Web (n.d.)
9. Lynne Diligent, "The Technology of Ancient Scrolls," Web (2013).
10. Oliver Wild, "The Silk Road" (1992).
11. Jonathan M. Bloom, "Silk Road or Paper Road?," The Silk Road Foundation, Web (n.d.)
12. "Ancient Writing Materials," Web (n.d.)

Images

1. Aethralis (Own work) [CC BY-SA 3.0 (<http://creativecommons.org/licenses/by-sa/3.0>) or GFDL (<http://www.gnu.org/copyleft/fdl.html>)], via Wikimedia Commons
2. "Silk Route" by Whole_world_-_land_and_oceans_12000.jpg: NASA/Goddard Space Flight Center derivative work: Splette (talk) - Whole_world_-_land_and_oceans_12000.jpg. Licensed under Public Domain via Wikimedia Commons - http://commons.wikimedia.org/wiki/File:Silk_route.jpg#mediaviewer/File:Silk_route.jpg
3. Ytrottier (Own work) "Chinese Hemp Paper Western Han" Licensed under CC BY-SA 3.0 via Wikimedia Commons - http://commons.wikimedia.org/wiki/File:Chinese_hemp_paper_western_han.jpg#mediaviewer/File:Chinese_hemp_paper_western_han.jpg

Disrupting Society From Tablet to Tablet



This work is licensed under a [Creative Commons Attribution-NonCommercial 4.0 International License](https://creativecommons.org/licenses/by-nc/4.0/).

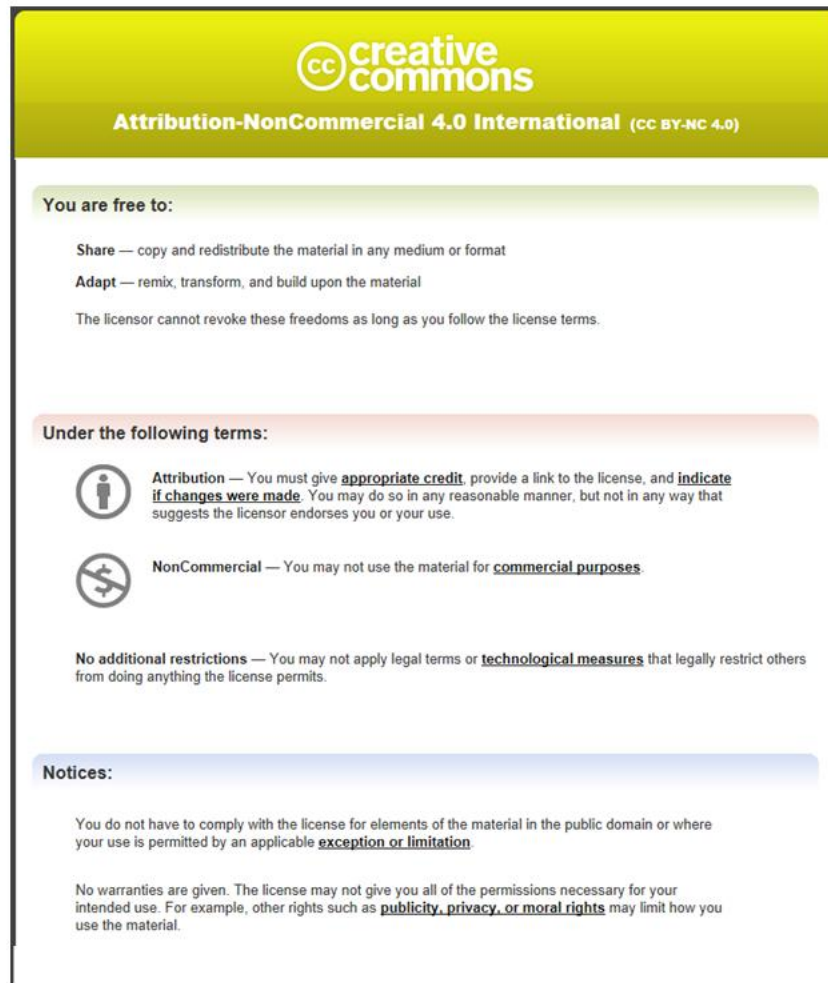

Suggested Attribution: Author. “Chapter Title”. *Book Title*. CC BY-NC

Images within chapter: All images within the chapters are Creative Commons or Public Domain images. Please see the chapter reference page for individual reuse license agreements.

Cover page image:

Clay Tablet. Babylonian maps/ Wikimedia Commons United States Public Domain