

# The joining of aluminium extrusions

R. E. Dolby, K. I. Johnson, W. M. Thomas

*The basic principle of Friction Stir welding (FSW) is described and recent applications reviewed, with particular emphasis on aluminium extruded and rolled products.*

*The tool employed during FSW is critical in determining weld quality and reliability, particularly the probe. Probe types developed to-date are described, together with their main areas of application. Recent developments in probes for butt-welding include the Whorl™ and MX-Triflute™ and the form and advantages of these are presented. Lap welding by FSW is more difficult than butt. Flared-Triflute™ and the A-Skew™ tools are currently under development for lap welding and show great promise in overcoming these difficulties.*

Parole chiave: aluminum, welding

## INTRODUCTION

It has long been recognised that frictional heating can be used to join, process and treat materials. Friction stir welding (FSW) is a process for joining workpieces in the solid-phase, using an intermediate non-consumable tool made of material that is harder than the workpiece material being welded (see fig 1).

FSW is a continuous hot shear process invented and patented by TWI in 1991. It involves slowly plunging a portion of a specially shaped rotating tool between, and then along, the abutting faces of the joint. The marked difference between the elevated temperature properties of the tool and the workpiece, along with a suitable cyclic movement between the tool and the workpiece, generates sufficient frictional heat to cause plasticised (third-body) conditions in the workpiece material. The contacting surface of the shoulder of the tool and the length of the probe below the shoulder essentially allow the probe to maintain penetration to the required through-thickness depth.

Initially FSW was confined to relatively soft workpiece materials such as aluminium, lead, zinc and magnesium. However, the weldability of copper, steel and titanium alloys has also been demonstrated (1-5). The welding of such harder workpiece materials has been possible by maintaining a suitable differential between the elevated temperature properties of the tool and of the workpiece materials.

Although incipient melting during welding has been reported for some materials, FSW can be regarded as a solid state, autogenous keyhole joining technique. The weld metal is thus free from defects typically found when fusion welding, eg porosity. Furthermore, and unlike fusion welding, no consumable filler material or profiled edge preparation is normally necessary.

FSW is now a practical technique for welding aluminium rolled and extruded products, ranging in thickness from 0.5 to 75 mm, and is used in commercial production worldwide. The present paper describes the current state of application of the process, together with future possible applications. It also covers recent developments in tool design as this is the key to the successful application of the process.

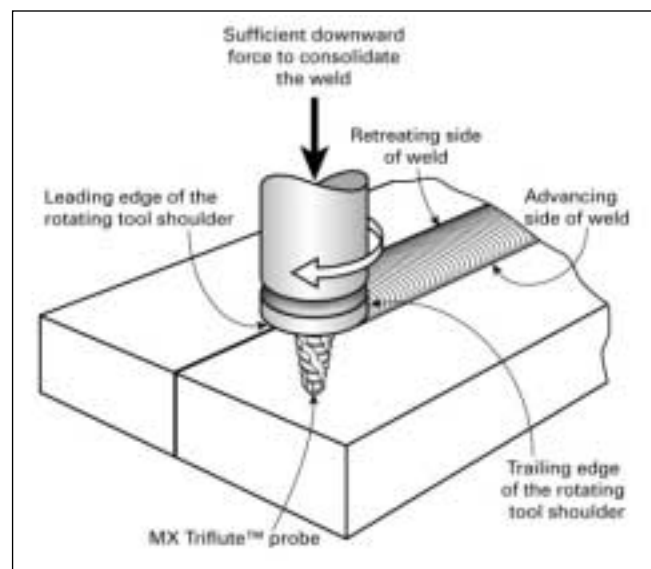

Fig 1 Basic principle of the FSW process

Fig 1 Principio di base del processo FSW

## APPLICATIONS OF FSW

Although FSW was only invented 11 years ago, its current industrial application is substantial, but to-date is mostly confined to the butt welding of aluminium rolled and extruded products. Applications have been recently reviewed (6, 7 & 8) and include welding of the following aluminium components:

- extruded panels for fishing boat freezing equipment(8)
  - extruded high speed ferry panels(8)
  - extruded floor and body panel for rail rolling stock(8)
  - rolled sheet fuel tanks for aerospace applications(7)
  - wrought wheels for automotive applications(6)
  - extruded/wrought automotive suspension arms(6)
- Other applications which are actively being developed for production include:
- tailor welded blanks for automotive panels(8,6)
  - wrought components for aerospace rocket frames(7)
  - wrought airframe structures for civil aircraft(7)

With regard to more long-term applications, investigations at TWI are continuing to explore and develop a number of techniques for welding extrusions and hollow sections. FSW of certain thin walled hollow sections requires internal mandrel support, e.g. a moving anvil or a hydraulically actuated or scissor action support, see Fig 2a, b & c.

R. E. Dolby, K. I. Johnson, W. M. Thomas  
TWI Ltd, Gt Abington, Cambridge, UK

Paper presented at the: Aluminium Two Thousand,  
5<sup>th</sup> World Congress, Rome 18-22 March 2003

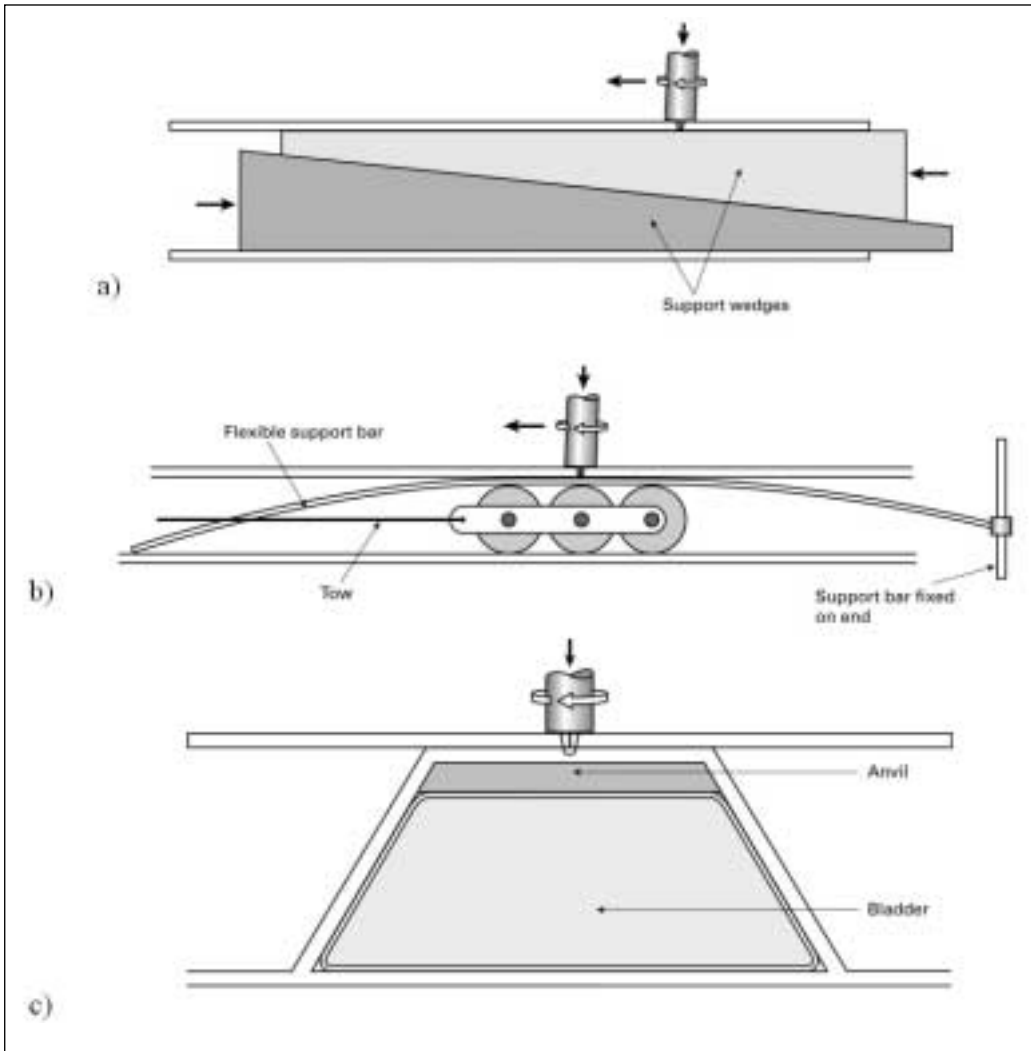

Fig 2 Extrusion & hollow section supports for FSW  
a) collapsible mandrel support  
b) roller support  
c) hydraulic bladder/anvil support

Fig 2 Supporti per la saldatura mediante FSW di pezzi estrusi e a sezione cava  
a) supporto a mandrino ripiegabile  
b) supporto a rotelle  
c) supporto a camera d'aria/incudine idraulico

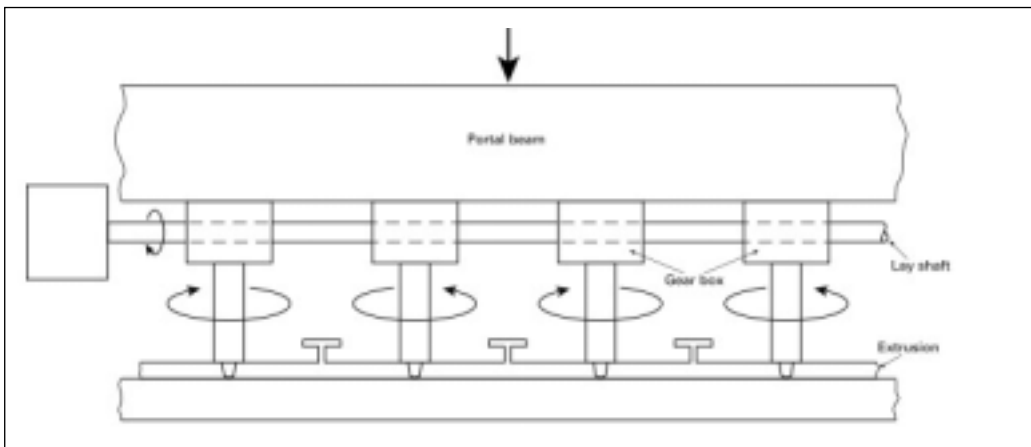

Fig 3 Multi-head friction stir welding

Fig 3 Saldatura FSW a testa multipla

Invariably manufacturers aim to fabricate their products as fast as possible. Increasing the welding speed or, for certain applications, the use of purpose designed multi-headed friction stir welding machines, can increase productivity and profitability. Figure 3 illustrates a design concept for an opposed rotation multi-head friction stir welding machine. Such opposed tool rotation balances side force asymmetry and enables a reduction in the clamping force needed to hold the plates together.

FSW TOOLS

Although FSW consistently gives high quality welds this can only be achieved by proper use of the process and con-

trol of a number of parameters. A key factor in ensuring weld quality is the use of an appropriate tool. The importance of the tool is illustrated in the following recent example involving the lap welding of 6mm 5083-0 condition aluminium alloy wrought sheet. In preliminary trials a conventional cylindrical threaded pin probe tool was used which gave a good as-welded appearance. However, bend testing showed the weld to be weak due to excessive thinning of the top sheet and thickening of the bottom sheet caused by a pressure differential during welding, see Fig 4. The failure followed the original interfacial surface oxide layers which, in 5083-0 condition material, are known to be particularly tenacious. The above problems were caused because, although the tool

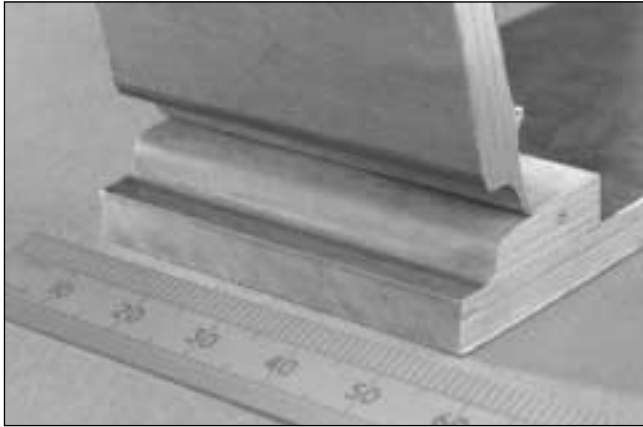

Fig 4 Hand bend tested lap weld in 6mm thick, 5083-0 condition sheet made at a welding speed of 2mm/sec (120mm/min). Severe plate thinning on the retreating side of the top plate (see Fig 1) is evident

Fig 4 Saldatura a sovrapposizione curvata a mano in una lamiera in lega 5083-0 dello spessore di 6mm a una velocità di saldatura di 2mm/sec (120mm/min). E' evidente un severo assottigliamento sul lato retratto della lamiera superiore (Fig 1)

employed gave satisfactory welds when butt welding plate components, its use when lap welding was inappropriate. Lap welding requires a modified tool to ensure full disruption of the interfacial oxide layers and a wider weld than is required when butt welding.

Fig 5 Probe types developed at TWI for various material thicknesses and joint types

Fig 5 Tipi di sonde sviluppate alla TWI per diversi spessori di materiali e tipi di saldatura

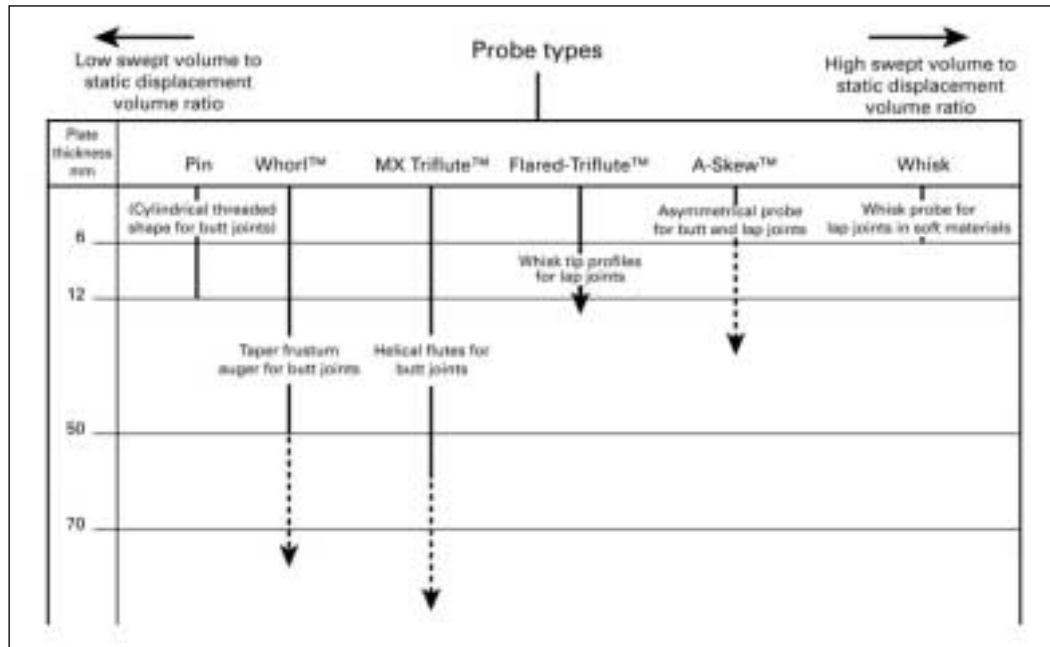
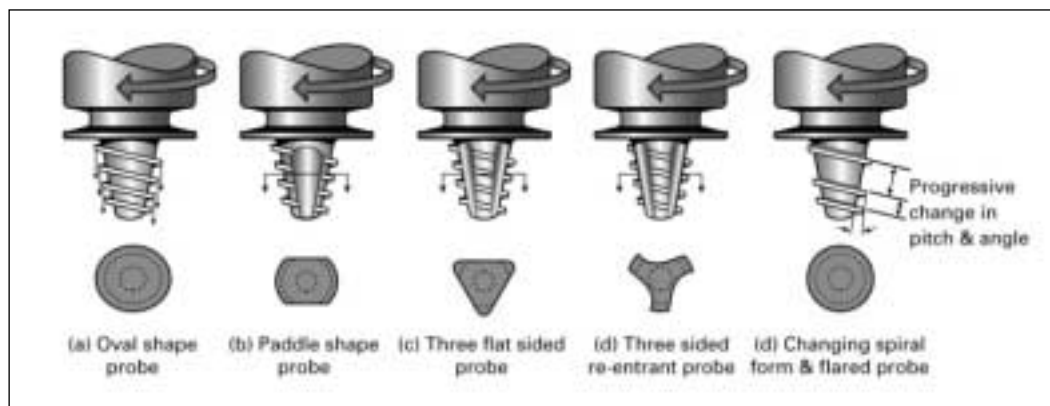

Fig 6 Basic variants for the Whorl™ type probes

Fig 6 varianti di base delle sonde Whorl™



This example above illustrates that good welding can only be achieved by the use of a tool appropriate to the application and a number of tools have been developed at TWI over the last 11 years to accommodate a number of materials, component thicknesses and joint types, as shown in Fig 5.

**Tools For Butt Welding**

The conventional cylindrical threaded pin probe is adequate for butt welding aluminium of thickness up to ~12mm. When welding thicker plate the Whorl™ and MX-Triflute™ should be used. As Fig 5 indicates these are capable of welding up to 50mm and 60mm thicknesses respectively. Typical forms of these tools are shown in Figs 6 and 7. These tools have an additional benefit in that they are capable of welding speed >x2 that achievable with the conventional probe.

Both types of probe have flat or re-entrant features or, in the case of certain Whorl™ probes, an oval cross-section, which reduce the probe volume and achieve a suitable swept volume to static volume ratio. The greater the swept to static volume ratio, the greater the path for material flow and the more efficient is the probe. In addition, these re-entrant features, especially the helical coarse ridges around the lands, help break up and disperse the surface oxides within the joint region.

**Tools For Lap Welding**

Lap welding by FSW is more difficult than butt welding as:

- wider welds are necessary to transmit the load properly in the manufactured structure

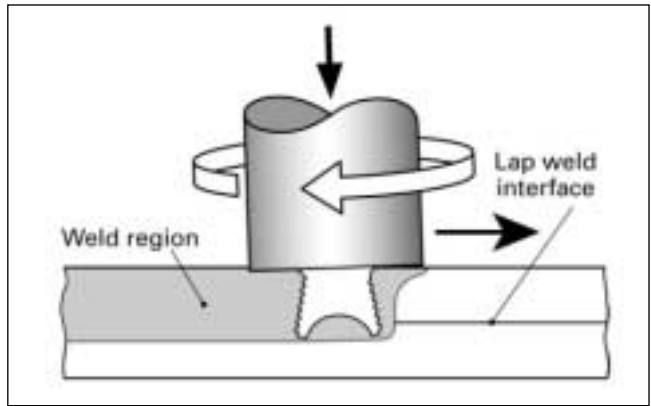
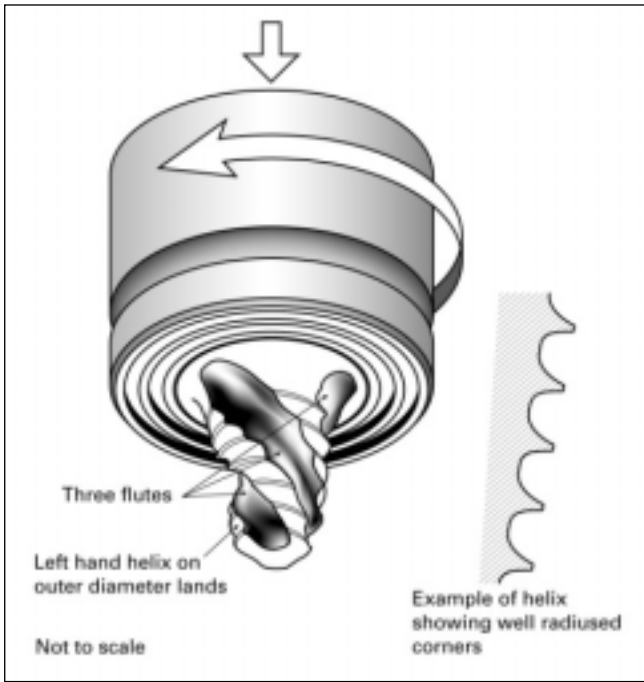

Fig 9 Flare-Triflute™ tool with lap welding whisk profile positioned across the weld interface

Fig 9 Attrezzatura Flare-Triflute™ con profilo per la saldatura di pezzi sovrapposti posizionato attraverso l'interfaccia di saldatura

Fig 7 Typical MX-Triflute™ probe

Fig 7 Tipica sonda MX-Triflute™

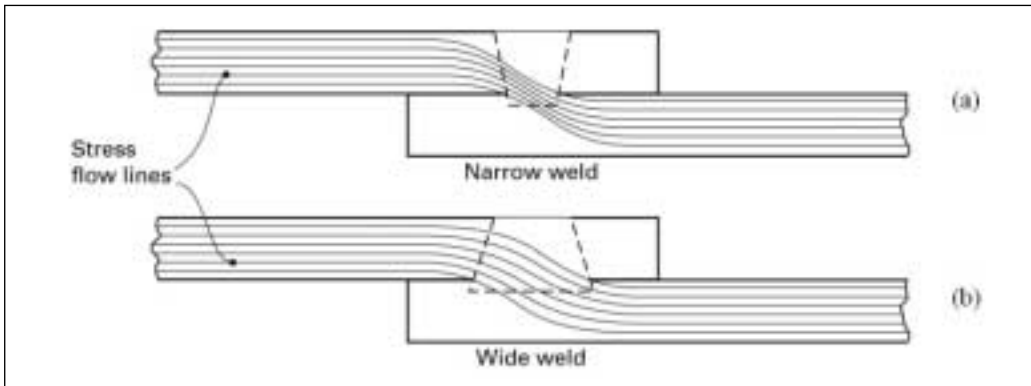

Fig 8 Comparative stress flow lines

(a) Narrow weld width - high stress concentration  
(b) Wide weld width - low stress concentration

Fig 8 Linee comparative del flusso di tensioni

(a) larghezza di una saldatura stretta - alta concentrazione di tensione  
(b) larghezza di una saldatura larga - bassa concentrazione di tensione

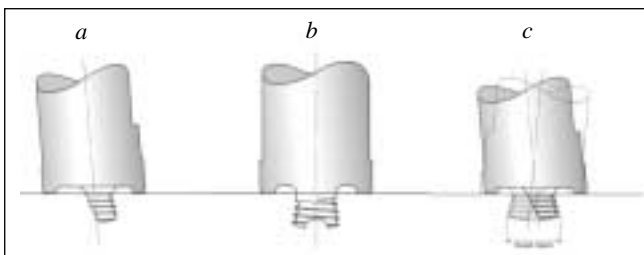

Fig 10 Prototype A-Skew™ Probe

a) Side view  
b) Front view, showing probe profile  
c) Swept region encompassed by skew action during welding

Fig 10 Sonda prototipo A-Skew™

a) vista laterale  
b) vista frontale che mostra il profilo della sonda  
c) Regione circondata dall'azione obliqua durante la saldatura

- the form of the notch, particularly at the tip at the edge of the weld, must be modified to ensure maximum strength (particularly fatigue strength) of the manufactured structure
- the oxide disruption at the sheet interface is more difficult because of the orientation of the joint interface and the FSW tool

With regard to the width of the weld, Fig 8 illustrates that stress is concentrated more severely at the notch tips of unbonded regions when the weld width is reduced. This assumes that the morphology of the tip region in both the narrow

and wide welds is similar.

The detailed morphology of the notch tip either side of the weld is critical to joint mechanical performance. Special tools are under development to minimise the extent of the tip area and control its orientation with respect to the sheet interface, specifically the Flared-Triflute™ and A-Skew™, see Fig 5. The forms of these tools are shown in Figs 9 and 10.

A lap joint made with a Flared-Triflute™ probe is shown in Fig 11(a). In this example the width of the weld region is 190% of the plate thickness and little upper plate thinning is apparent. (The corresponding figure achieved when using a conventional threaded pin probe is 110%). The notch tip at the edge of the weld achieved using this tool is shown in Figs 11(b) and (c). It should be noted that the tip at the retreating side (Fig 11(b)) does not lie in a direction perpendicular to the sheet interface as it does when a weld made with a conventional pin probe is employed. The tip at the advancing side (Fig 11(c)), however, turns in a direction perpendicular to the sheet interface, but this is much less pronounced than obtained when a conventional pin is used.

More promising results have also been achieved with the A-Skew™ tool. Fig 12 shows a weld made at the same conditions as Fig 11, but using this tool. Figs 12 (b) and (c) show a much improved alignment of the edge notch, even on the advancing side.

Bend testing of the above welds further showed that the oxide disruption at the sheet interface was significantly greater than achieved with the conventional pin probe. The latter

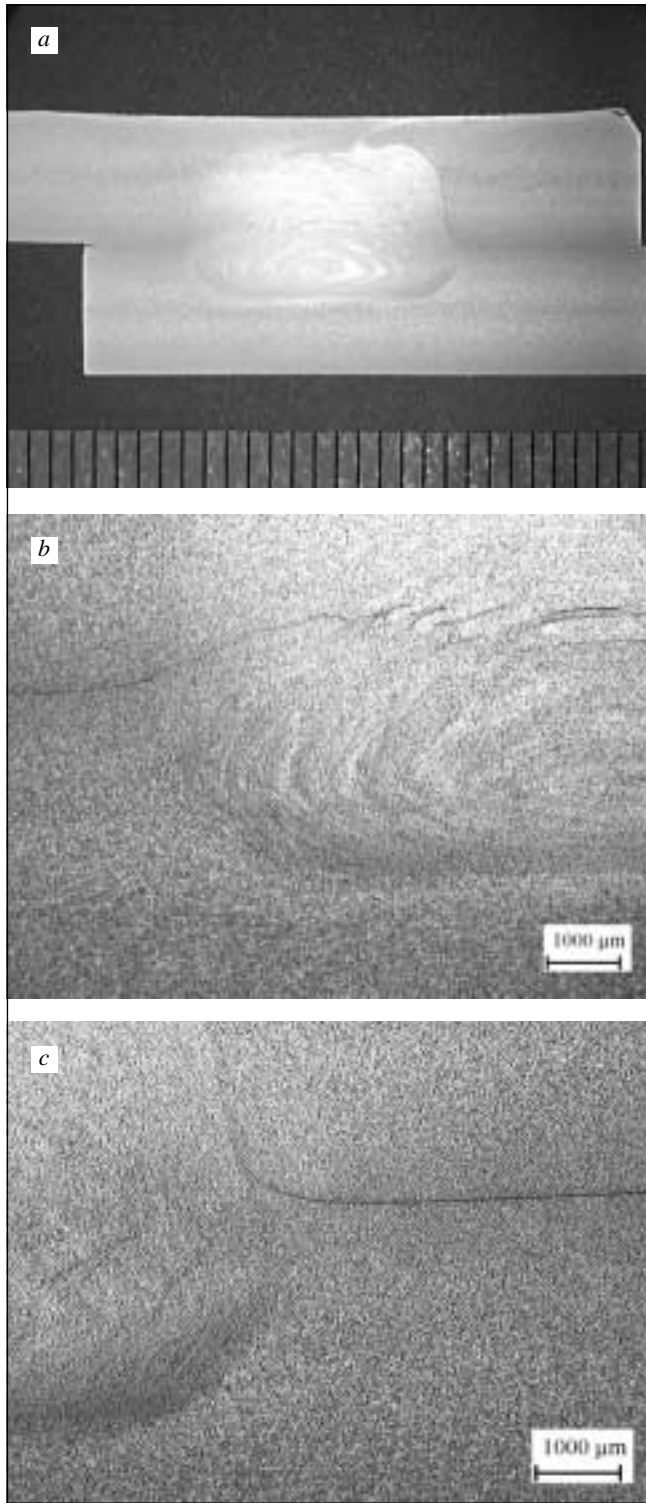

Fig. 11 Lapweld made using a Flared-Triflute™ probe in 6mm thick 5083-0 condition aluminium alloy, at a welding speed of 4mm/sec (240mm/min)

- a) Macrosection
- b) Detail of notch at the retreating side
- c) Detail of notch at the advancing side

Fig. 11 Saldatura di pezzi sovrapposti ottenuta con sonda Flared-Triflute™ in una lega di alluminio 5083-0 dello spessore di 6mm, con velocità di saldatura di 4mm/sec (240mm/min)

- a) Macrosezione
- b) Dettaglio di un intaglio nel lato retratto
- c) Dettaglio di un intaglio nel lato avanzato

showed failure early in the bend test typically as shown in Fig 4, whilst the former gave welds which were capable of >90° bend without failure. Promising results are being

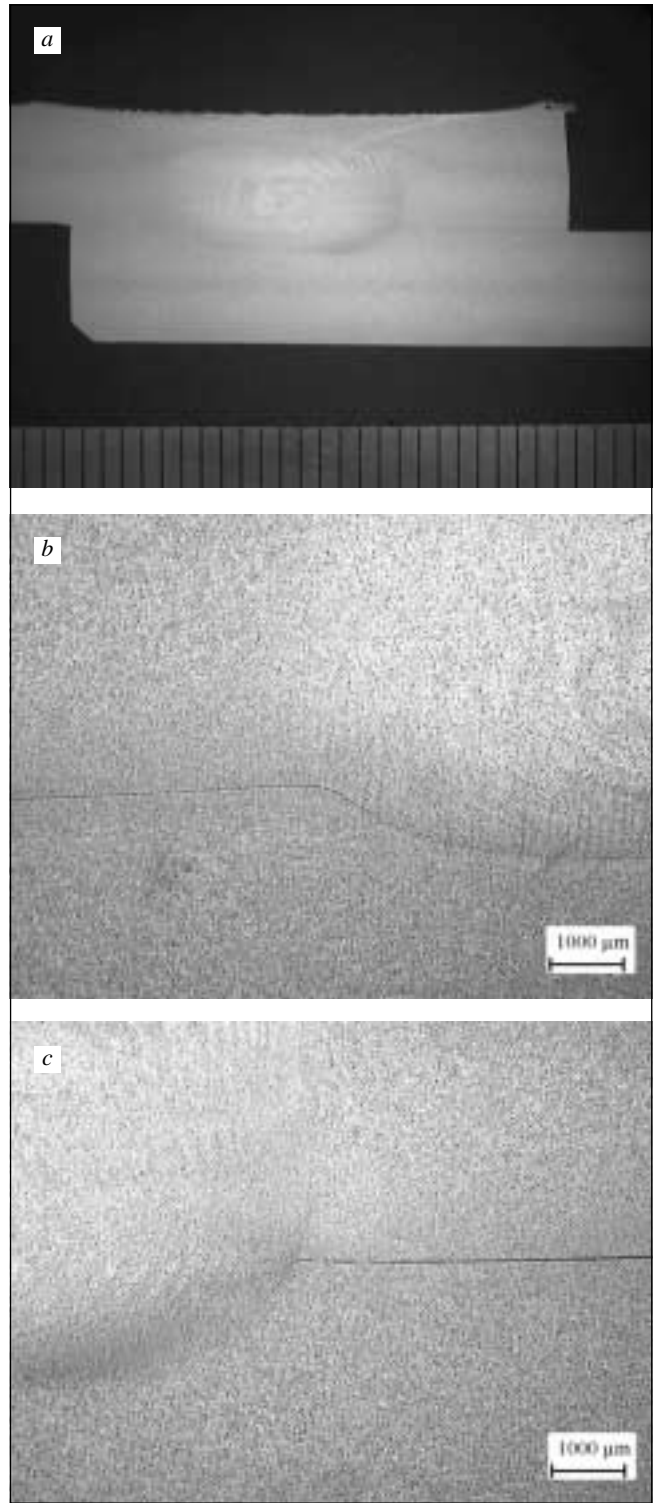

Fig. 12 Lapweld made using a A-Skew™ probe in 6mm thick 5083-0 condition aluminium alloy at a welding speed of 4mm/sec (240mm/min)

- a) Macrosection
- b) Detail of notch at the retreating side
- c) Detail of notch at the advancing side

Fig. 12 Saldatura di pezzi sovrapposti ottenuta con sonda A-Skew™ in una lega di alluminio 5083-0 dello spessore di 6mm, con velocità di saldatura di 4mm/sec (240mm/min)

- a) Macrosezione
- b) Dettaglio di un intaglio nel lato retratto
- c) Dettaglio di un intaglio nel lato avanzato

achieved in fatigue tests on overlap welds made with the two tool types. Testing is currently in progress, together with tool development.

SUMMARY AND CONCLUSION

This paper describes current applications of FSW on wrought and extruded aluminium products and patented techniques for use on hollow extrusions. Recent developments in FSW butt and lap-welding of such materials are also outlined - particularly a Flared-Triflute™ probe and an A-Skew™ probe. Both give lap welds of 190% of the plate thickness, an improvement in weld integrity, a reduction in upper plate thinning and an increased welding speed over current practice. Although significant improvements have been achieved, additional tool development work is underway to further minimise the occurrence and severity of defects associated with FSW lap welds.

ACKNOWLEDGEMENTS

The authors wish to thank D G Staines, I M Norris, E D Nicholas, P L Threadgill, I J Smith, E R Watts, A Leonard, A Duncan and P Evans.

REFERENCES

- 1) Boon T, Thomas W.M and Temple-Smith P: Friction welding apparatus and method Patent No. US 6,325,273 B1 (priority date December 6, 1996)
- 2) Andersson C G, Andrews R E, Dance B G I, Russell M J Olden E J, & Sanderson R M, 'A comparison of copper canister fabrication by the electron beam and friction stir processes'. Swedish Nuclear Fuel and Waste Management Co (SKB) and TWI. 1st FSW Symposium, 14-16 June 1999, Thousand Oaks, California, USA.
- 3) Colligan K J, Fisher J J, Gover E J, & Pickens J R, 'Friction stir welding in the advanced amphibious assault vehicle', Advanced Materials and Processes, September 2002.
- 4) Mishra R S, Mahoney M W, McFadden S X, Mara N A and Mukherjee A K: 'High strain rate superplasticity in friction stir welding processed 7075 Al alloy'. Scripta Materialia, 42 (2000), pp.163-168, 11 October 1999.
- 5) Dawes C J: 'Faster and faster – welding speed increases

with tool development – one of a series of steps'. Bulletin Vol. 41 No. 4, July/August 2000, pp.51-55.

- 6) Kallee S W, Nicholas D. 'Friction and forge welding processes for the automotive industry'. International Body Engineering Conference, Detroit, 28-30 September 1999, 99-IBECC-13.
- 7) Kallee S W, Nicholas E D, Thomas WM. 'Industrialisation of Friction stir welding for aerospace structures'. Structures and Technologies - Challenges for Future Launchers Third European Conference, 11-14 December 2001, Strasbourg, France.
- 8) Davenport J, Kallee S W & Wylde J G. 'Europe follows Japan into friction stir welding'. Railway Gazette, November 2001.
- 9) Ericsson M, 'Fatigue strength of friction stir welded joints in aluminium', Licentiate thesis, Department of Materials Science & Engineering, Royal Institute of Technology (KTH) S-10044 Stockholm, Sweden, May 2002.
- 10) Brooker M J, van Deudekom A J M, Kallee S W, Sketchley P D: 'Applying Friction Stir Welding to the Araine 5 Main Motor Thrust Frame'. Fokker Paper, European Conference on Spacecraft Structures, Materials and Mechanical Testing, 29 Nov – 1 Dec 2000, Estec, Noordwijk, The Netherlands.
- 11) Cederquist L and Reynolds A.P: Factors affecting the properties of friction stir welded aluminium lap joints Welding research supplement, (December 2001), pp 281-287.
- 12) Christner B, 'Development and testing of friction stir welding (FSW) as a joining method for primary aircraft structure', ICAS Congress 2002.
- 13) Matsumoto K & Sasabe S: 'Lap Joints of Aluminium Alloys by Friction Stir Welding'. Proc. 3rd International Friction Stir Welding Symposium, Kobe, Japan, 27-28 Sept, 2001.
- 14) Smith C B, Crusan W, Hootman J R, Hinrichs J F, Heideman R J, Noruk J S. 'Friction stir welding in the automotive industry'. Tower Automotive - Technology Application, 3533 N 27th St, Milwaukee WI, 53216.
- 15) Thomas W M, Braithwaite A B M, & John R: 'Skew-Stir™ technology' Proc. 3rd International Friction Stir Welding Symposium, Kobe, Japan, 27-28 Sept, 2001

A B S T R A C T

SALDATURA DI ESTRUSIONI DI ALLUMINIO

**KEYWORDS:**  
alluminio e leghe, saldatura

Nella memoria si descrive principio di base della tecnica di saldatura denominata Friction Stir welding (FSW) e si offre una panoramica delle recenti applicazioni, con particolare rilievo sui prodotti di alluminio estrusi e laminati. L'attrezzatura impiegata per il FSW, e in particolare la sonda, è de-

terminante per la qualità e affidabilità della saldatura. Vengono descritti i tipi di sonda attualmente disponibili e i loro campi di applicazione principali. Gli sviluppi recenti delle sonde per saldatura includono Whorl™ e MX-Triflute™ e vengono presentati la loro forma ed i loro vantaggi. La saldatura mediante FSW di parti sovrapposte è più difficile della saldatura di estremità. Attualmente sono in via di sviluppo le promettenti apparecchiature Flared-Triflute™ e A-Skew™ per la saldatura di parti sovrapposte che permetteranno di superare queste difficoltà.