

# THE INFLUENCE OF THERMAL BRIDGES ON REFRACTORY LININGS

G. Forni, P. Recalcati, M. Nestani

*In this study we analyze the influence of thermal bridges caused by the presence of anchoring systems. The engineering, especially heat transfer calculation, allow the preventive definition of the most suitable insulating linings.*

*Thanks to the thermography, it is possible to determine which are the parameters that actually influence the heat transfer process, thus to work with not only theoretical values but also actual ones. Corrective actions together with general considerations are illustrated in this study, supported by drawings, pictures and thermo graphics scans.*

KEYWORDS: stainless steel, refractories, oxidation, welding

## DESIGNING REFRACTORY LININGS

There are several factors which must be considered while designing a refractory lining; a complete and correct preventive analysis is of vital importance to determine the final theoretical values so that they will be very close to the actual ones.

The most important ones can be summarize as follows:

- TYPE OF LINING: wall or roof.
- Target temperature values to be obtained (normally specified by furnace constructor)
- THEORETICAL STUDY OF THE LINING: this is the first phase where type of refractories and layers thicknesses are determined. In Fig. 1 few examples of configurations for the lining of wall and roof.

The first variable to be determined, if not yet specified by furnace builder is the total thickness of the lining and of each layer; for this purpose, software for the heat transfer calculations are needed; these softwares take into accounts application temperature, ambient temperature and thermal conductivity of chosen refractory. The layer on the hot face, facing working temperature, is generally made of dense refractories which main feature is that of withstanding the thermal conditions at which is subjected. Accordingly this layer has not insulating power; this is left to the following layers which are made of insulating refractories such as IFB or boards having decreasing density as you move towards the outer shell.

Giancarlo Forni - Paolo Recalcati  
Linco Baxo - Milano  
Massimo Nestani  
Flir - Milano

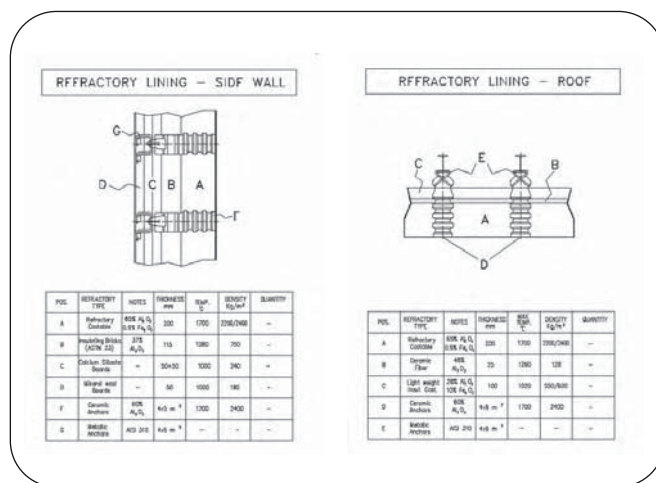

Fig. 1

1a: wall configuration 1b: roof configuration.  
1a: specifica parete 1b: specifica volta.

Such products are available in specific formats and therefore engineering take this into account while designing the thicknesses of the layers.

Insulating bricks, Gr. 23/26 - density 750÷850 kg/m<sup>3</sup> or 450 kg/m<sup>3</sup>, are available in the following formats: 220x110x60mm / 230x115x65mm / 250x125x65mm.

Generally it is recommended to lay bricks on the longer sides (i.e. 250÷220mm, or 125÷110mm.) to obtain good stability of the lining. Boards of ceramic fibres, calcium silicate, rock wool are generally located between IFB layer and casing so as to have a better and linear thermal dispersion flow.

For roofing, after the dense layer, ceramic fibre blankets

AISI standard	UNI standard	Max Temperature
AISI 304	X 5 Cr Ni 1810	900° C.
AISI 310 / 310s	X 22 Cr Ni 2520 / X 6 Cr Ni 2520	1.110° C.
AISI 314	X 16 Cr Ni Si 12520	1.150° C.

▲  
Tab. 1

**maximum continuous service temperature in air of most common stainless steel.**

Temperature di utilizzo continuo dei più comuni acciai inossidabili.

and insulating castable (900÷450 kg/m<sup>3</sup>) are respectively used to insulate.

• ANCHORS TYPE: quantity and type of anchors, a must for monolithic walls and roof lining are chosen according to the working temperature and to the type of refractory being installed.

### METALLIC ANCHORS

They are used when temperature are not very high (max 1050÷1150 °C) and can be made in many different shapes; metallic anchors are made with stainless steel thanks to its high resistance to oxidation in hot environment.

The high content of chrome that combined with oxygen to form very stable superficial oxides, protect the material beneath from developing further oxidation. Table 1 shows maximum continuous service temperature in air of most common stainless steel. Metallic anchors are coated with tar and welded to the casing with proper electrodes. As shown in Fig. 4 and Fig. 5, anchors are placed with typical pitch of 300mm. (12 pcs/m<sup>2</sup>); accordingly in this case, the outside shell temperature is strongly influenced by the presence of such anchor system. The actual shell temperature will then be higher than values obtained by theoretical calculations: the temperatures will increase as the number of anchors goes up.

#### CALCOLI DI DISPERSIONE TERMICA

CLIENTE :	
ZONA : VOLTA	
PROGETTO N° :	DISEGNO :
PROGETTO :	

TEMPERATURA INTERNA	1250°C	ALPHA INTERNO	50,00W/m <sup>2</sup> K
TEMPERATURA ESTERNA	20°C	ALPHA ESTERNO	12,39W/m <sup>2</sup> K
COEFFICIENTE DI EMISSIVITA'	0,60		
VELOCITÀ DEL VENTO	0,00m/s		
QUANTITÀ DI CALORE DISPERSA	1263,39W/m <sup>2</sup>		
TEMPERATURA INTERNA	1225 °C		
TEMPERATURA MANTELLO	122 °C		

STRATO	CODICE	MATERIALE	SPESS.	LAMBDA	T. MAX	T. MED
1°	LF 2 020	Licofest 1600 0-10 QH	180mm	1,11W/mK	1225°C	1122°C
2°	TP 11/003	LM 1260 d.128 blanket	20mm	0,22W/mK	1019°C	961°C
3°	LF 6 004	Licofest L 05	100mm	0,16W/mK	903°C	512°C
TOTALE			300mm			

IL CALCOLO E' STATO ESEGUITO PER UNA VOLTA SOPESEA  
ALPHA ESTERNO CALCOLATO SECONDO LANGMUIR (ASTM)  
FATTORE C FISSATO 1,79  
VALORE K FISSATO 2,80

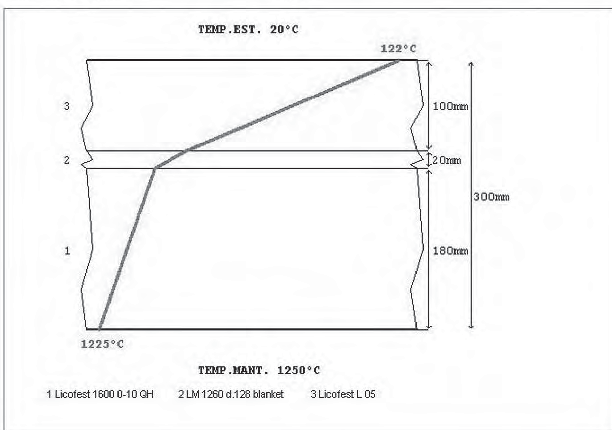

NOTA I risultati del calcolo sono stati ottenuti attraverso valori teorici e medi rilevati sulle ns. schede tecniche con le normali tolleranze ammesse. I calcoli non tengono conto in nessun caso dell'influenza dei ponti termici.

▲  
Fig. 2

**Heat transfer calculations - roof with ceramic anchor.**

Calcolo termico - volta con ancoraggio ceramico.

#### CALCOLI DI DISPERSIONE TERMICA

CLIENTE :	
ZONA : Pareti con Ancoraggi Ceramici	
PROGETTO N° :	DISEGNO :
PROGETTO :	

TEMPERATURA INTERNA	1250°C	ALPHA INTERNO	50,00W/m <sup>2</sup> K
TEMPERATURA ESTERNA	20°C	ALPHA ESTERNO	9,24W/m <sup>2</sup> K
COEFFICIENTE DI EMISSIVITA'	0,60		
VELOCITÀ DEL VENTO	0,00m/s		
QUANTITÀ DI CALORE DISPERSA	556,40W/m <sup>2</sup>		
TEMPERATURA INTERNA	1239 °C		
TEMPERATURA MANTELLO	81 °C		

STRATO	CODICE	MATERIALE	SPESS.	LAMBDA	T. MAX	T. MED
1°	BC spec.002	Refractory Castable	200mm	1,14W/mK	1239°C	1190°C
2°	MAREF BRICK 01	Insulating bricks-Gr.23	115mm	0,22W/mK	1142°C	996°C
3°	TP 12/001	Calcium Silicate boards	100mm	0,13W/mK	850°C	635°C
4°	TP 12/004	Mineral wool boards	50mm	0,08W/mK	421°C	251°C
5°	n.refr. 001	Casing	5mm	34,79W/mK	80°C	80°C
TOTALE			470mm			

IL CALCOLO E' STATO ESEGUITO PER UNA PARETE VERTICALE  
ALPHA ESTERNO CALCOLATO SECONDO LANGMUIR (ASTM)  
FATTORE C FISSATO 1,39  
VALORE K FISSATO 2,20

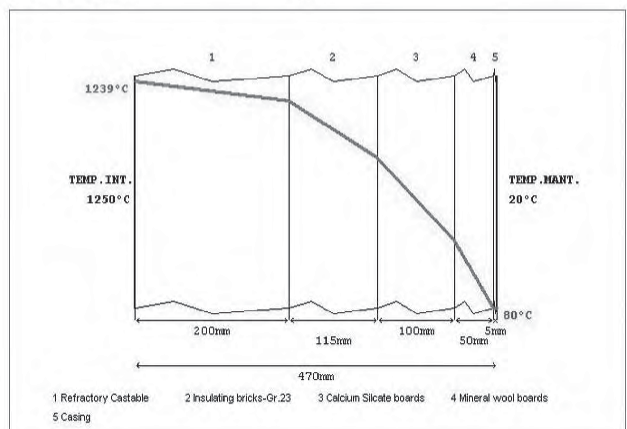

NOTA I risultati del calcolo sono stati ottenuti attraverso valori teorici e medi rilevati sulle ns. schede tecniche con le normali tolleranze ammesse. I calcoli non tengono conto in nessun caso dell'influenza dei ponti termici.

▲  
Fig. 3

**Heat transfer calculations - wall with ceramic anchor.**

Calcolo termico - parete con ancoraggio ceramico.



Fig. 4

**Stainless steel anchor welding.**

*Saldatura ancoraggi metallici.*



Fig. 5

**Stainless steel anchor welding.**

*Saldatura ancoraggi metallici.*

**CERAMIC ANCHORS**

Ceramic anchors are used when temperatures exceed 1050÷1150°C and are manufactured by means of processing plastic mix which are then fired. The maximum service temperature / up to 1700 °C) depends on refractory material they are made of; normally they are made with high density mixtures (2400 kg/m<sup>3</sup>) with high alumina content (abt. 60% Al<sub>2</sub>O<sub>3</sub>) low iron content (<1,5%) exhibiting high mechanical resistance. As shown on following drawings, ceramic anchors, are placed with typical pitch of 450÷500 mm(=5÷4 pcs/m<sup>2</sup>), therefore with lower number of pieces compared to metallic system with consequent less number of thermal bridges. Ceramic anchors are not directly fixed to the casing as their role is that of holding the first hot layer, in fact they are hold/fixed by means of stainless steel rods or rods plus clamps which are designed to accommodate natural movements of the lining caused by expansion and shrinkage of the refractories during the operation.

Fig. 8 shows S.S. rods welded to the casing through a plate that allows it to "move", which are attached to the ceramic anchor as shown on Fig. 9; special attention is required when placing insulating materials around anchors in order to ensure that all area around is filled with material to avoid any empty space which may cause temperature to leak to the metallic components of this system (i.e. S.S. rods and clamps) which with time deform moving forward the whole lining; it is therefore strongly recommended to fill any space around head of ceramic anchor with ceramic fibres (Fig. 10-11)

- Type of refractory and its installation: refractory products which can be used for linings may differ according to the area of installation, working conditions, type of installation (i.e. ramming, casting etc.) and their intrinsic nature. Thermal bridges are often a consequence of the chosen type of refractory for the hot face.

- Prefabricated blocks solution: an alternative solution to the conventional linings is represented by the pre-fab lining (Fig. 12-13). Main features are good stability, higher insulation and lower number of anchors and therefore of thermal bridges. As illustrated on following drawings,

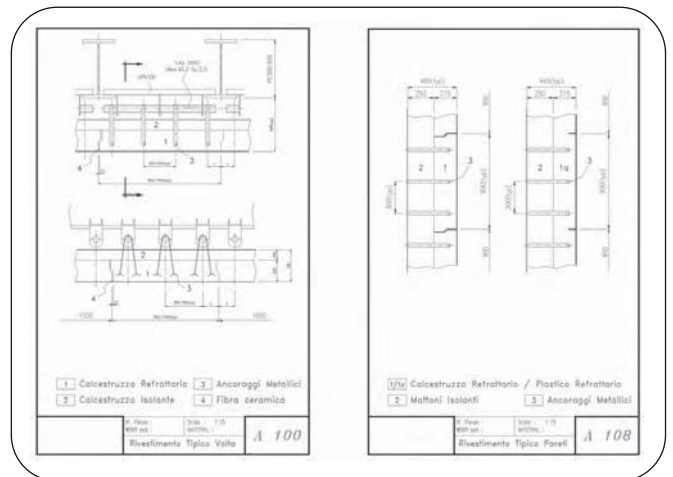

Fig. 6

**Typical pitch for stainless steel anchors.**

*Passo tipico per ancoraggi metallici.*

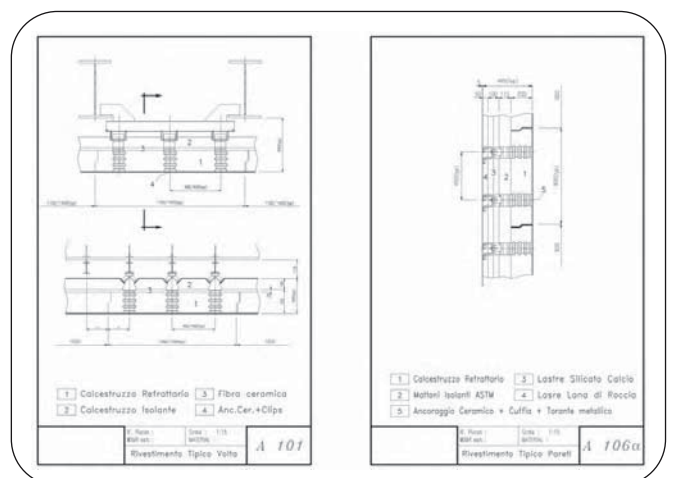
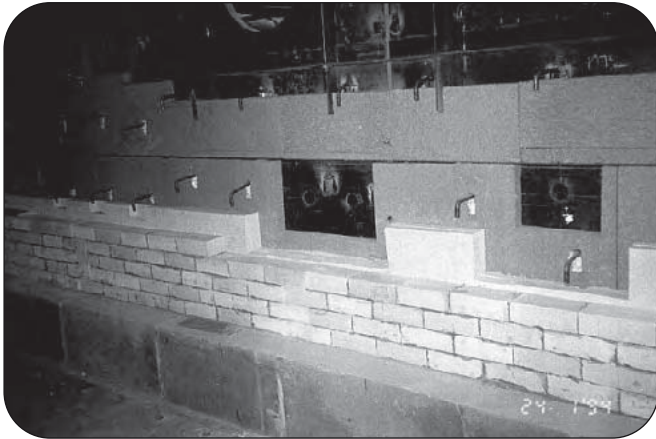

Fig. 7

**Typical pitch for ceramic anchors.**

*Passo tipico per ancoraggi ceramici.*





▲  
Fig. 8

**Stainless steel anchoring system for ceramic anchor.**  
*Sistemi di ancoraggio per ancoraggi ceramici.*



Fig. 9

**Ceramic anchors coupled with stainless steel anchors.**  
*Ancoraggi ceramici accoppiati a sistemi metallici.*



▲  
Fig. 10

**Ceramic anchors coupled with stainless steel anchors.**  
*Ancoraggi ceramici accoppiati a sistemi metallici.*



▲  
Fig. 11

**Ceramic fibre anchor head wrapping.**  
*Isolamento teste ancoraggi ceramici.*

a



b



▲  
Fig. 12

**Prefabricated wall lining.**  
*Pareti in blocchi prefabbricati.*

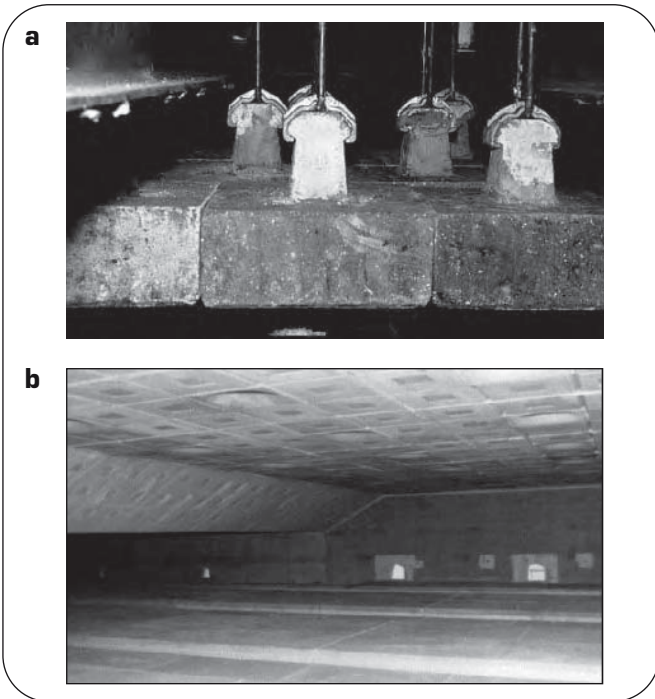

**Fig. 13**  
**Prefabricated roof lining.**  
 Volta in blocchi prefabbricati.

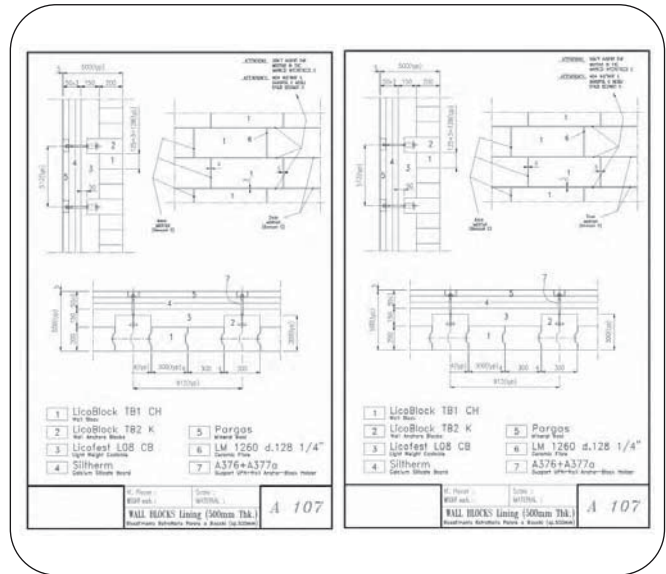

**Fig. 14**  
**Typical solution for prefabricated wall lining.**  
 Tipico per pareti prefabbricate.

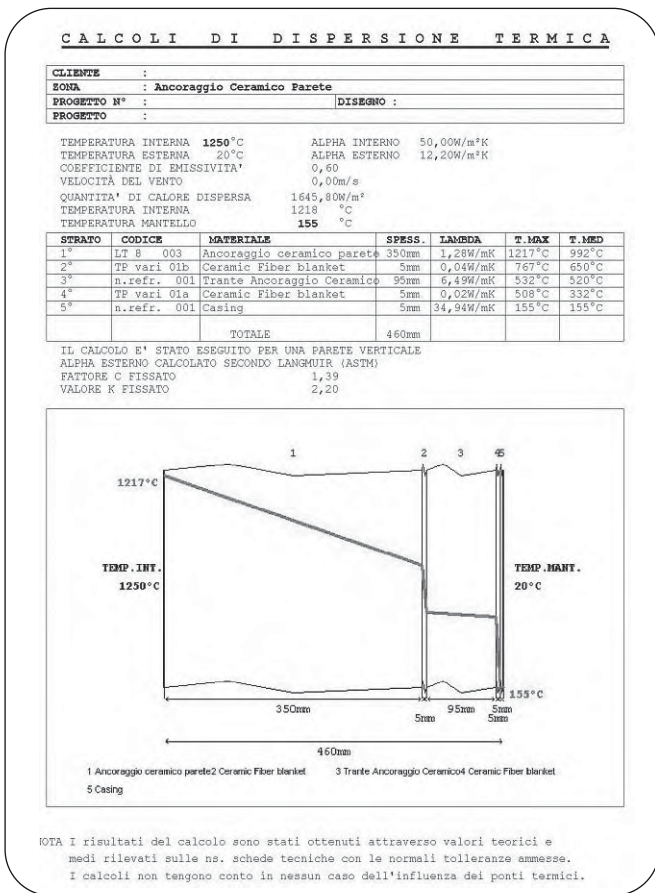

**Fig. 15**  
**Heat transfer calculation - wall ceramic anchor.**  
 Calcolo termico - ancoraggio ceramico parete.

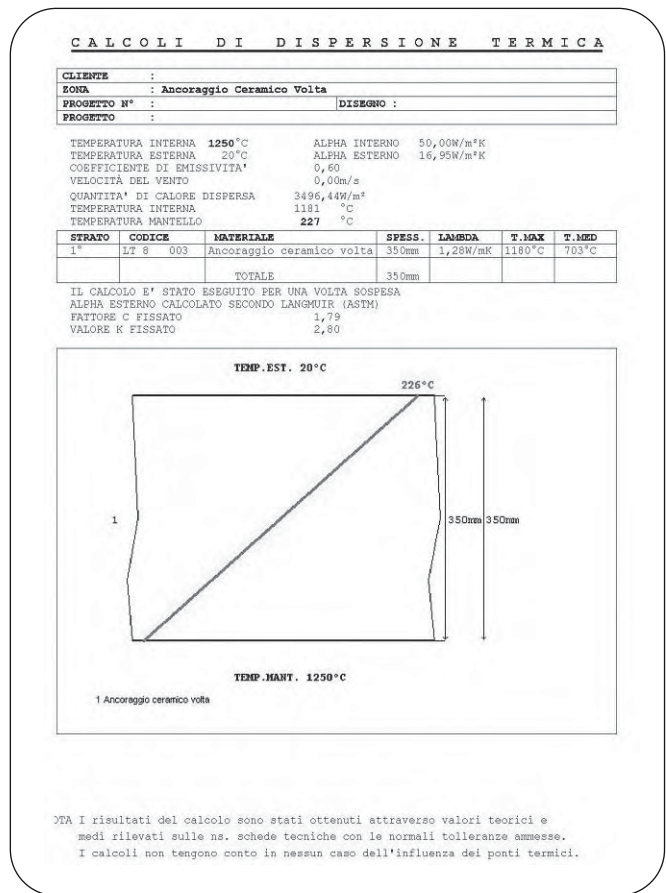

**Fig. 16**  
**Heat transfer calculation - roof ceramic anchor.**  
 Calcolo termico - ancoraggio ceramico volta.



Type of lining	Temperature of maximum insulation (THEORETICAL)	Anchor temperature (THEORETICAL)
WALL WITH CERAMIC ANCHOR	81 °C	155°C
ROOF WITH CERAMIC ANCHOR	122 °C	227°C

▲  
Tab. 2

**Temperatures through anchors.**

Temperature attraverso gli ancoraggi.

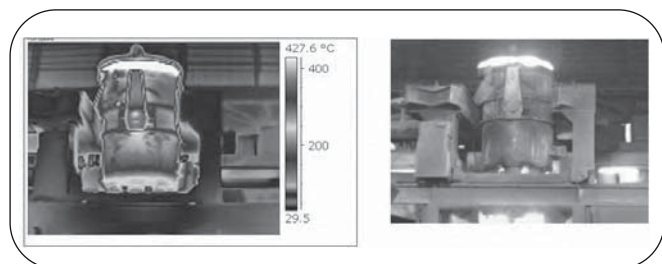

▲  
Fig. 17

**Thermography of a steel ladle.**

Termografia di una siviera di un'acciaieria a forno elettrico ad arco.

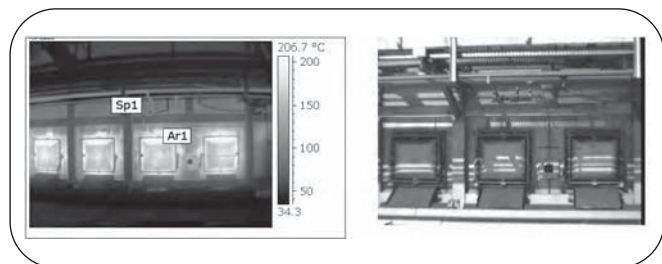

▲  
Fig. 18

**Thermographic scan of side wall inspection doors of a reheating furnace.**

Termografia di una parete di un forno di riscaldamento in corrispondenza di portine d'ispezione.

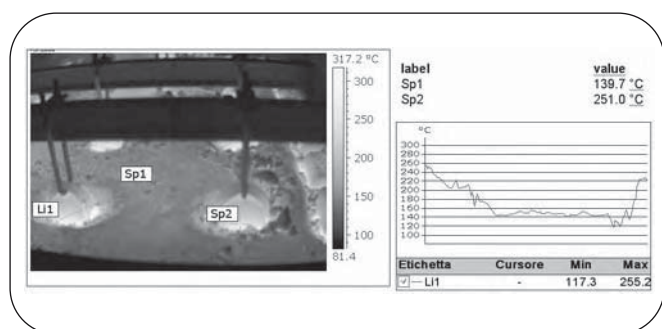

▲  
Fig. 19

**Thermography of roof with ceramic anchor.**

Termografia volta con ancoraggi ceramici.

ceramic anchors in the case of roof, are placed with a typical pitch of 500÷550mm (~4÷3,3 pcs/m<sup>2</sup>) while for wall lining metallic block holder are placed with a typical pitch of 500x900mm (2 psc/m<sup>2</sup>)

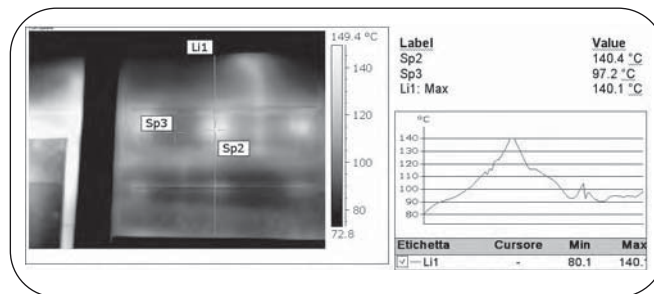

▲  
Fig. 20

**Thermography of wall with ceramic anchor.**

Termografia parete con ancoraggi ceramici.

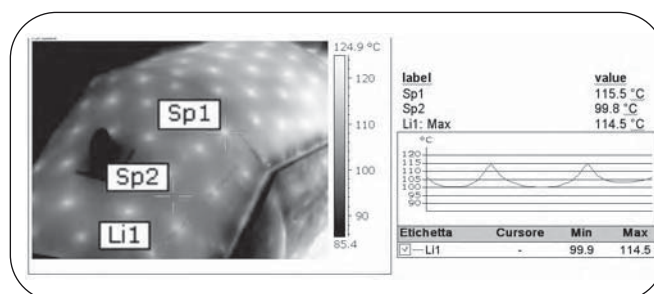

▲  
Fig. 21

**Thermography of duct with metallic anchor.**

Termografia condotto fumi con ancoraggi metallici.

## THEORETICAL ANALYSIS OF THERMAL BRIDGES

For a correct evaluation of thermal bridges it is first necessary to understand their theoretical impact. Heat transfer calculation are performed in proximity of both metallic and ceramic anchors (Fig. 15 and 16).

If we analyse the results (Tab. 2), we would note that temperatures through anchors, is higher than the rest of the lining.

## THERMOGRAPHY AND THE THERMOCAMERAS

In order to verify the theoretic temperatures obtained through heat transfer calculations, thermo graphic scans are made on the refractory lining, while the furnace is working.

The thermo graphic scans or infrared monitoring systems are made with the use of infrared thermal cameras which is equipped with special lenses which allow the machine to measure and to represent graphically the infrared radi-

Type of lining	Maximum insulating temperature (actual)	Anchor temperature (actual)
ROOF WITH CERAMIC ANCHOR	140 °C	251°C

Type of lining	Maximum insulating temperature (actual)	Anchor temperature (actual)
WALL WITH CERAMIC ANCHOR	97,2 °C	140,4°C

Type of lining	Maximum insulating temperature (actual)	Anchor temperature (actual)
WALL WITH METALLIC ANCHOR	99,8 °C	115,5 °C

ation released by an object. Since the radiation is a function of the objects surface temperature, the thermal camera is able to calculate and visualize the temperature.

The portable camera, light and handy, enables to directly accomplish the inspection of the areas of refractory linings.

The thermal images, instantly coloured with high resolution, can be analyzed directly on site, using the measuring markers included in the software of the thermal camera, or on PC, with special software for the analysis of infrared photos able to create relates reports.

The following figures show some examples of thermography of a steel ladle

The main advantage of thermography is to have an immediate picture with temperatures of targeted unit which gives the possibility to understand the origin of hot spots which otherwise would not be possible to determine.

This peculiarity makes thermocameras a very valuable instrument to make preventive maintenance planning, thus to constantly monitor the linings of running furnaces without risk of unexpected shut-down.

Fig. 18 is an example of thermographic scan of side wall inspection doors of a reheating furnace.

## EXAMPLE OF THERMOGRAPHY APPLIED TO REFRACTORY LINING

Fig. 19 to Fig. 21 display some examples of thermograph pictures for various areas of running furnaces with the aim of highlighting the different temperature values taken in function of the proximity of a thermal bridge created by the anchoring system (metallic or ceramic).

From the thermography in Fig. 19, the following factors are highlighted:

- Sp1=139,7°C ◊ Temperature of lining in the area of maximum insulation
- Sp2=251,0°C ◊ Temperature closed to ceramic anchors head
- Li1 ◊ Temperatures between anchors. You can note how temperature increases proportionally as they gets closed to the ceramic anchoring

From thermography in Fig. 20 we have the following information:

- Li3=85,9°C ◊ External temperature at maximum insulation point;
- Sp3=97,2°C ◊ External temperature at maximum insulation point;
- Sp2=140,4°C ◊ External temperature in proximity of S.S.

ROOF WITH CERAMIC ANCHOR	THEORETIC VALUE	ACTUAL VALUE	DIFFERENCE %
TEMPERATURE AT MAX INSULATING POINT	122°C	140°C	~+15%
ANCHOR TEMPERATURE	227°C	251°C	~+10%

▲  
Tab. 3

**Different theoretical temperatures and the real ones for roof.**

*Differenze tra le temperature teoriche e quelle reali per volte.*

WALL WITH CERAMIC ANCHOR	THEORETIC VALUE	ACTUAL VALUE	DIFFERENCE %
TEMPERATURE AT MAX INSULATING POINT	81°C	97,2°C	~+20%
ANCHOR TEMPERATURE	155°C	140,4°C	~-10%

▲  
Tab. 4

**Different theoretical temperatures and the real ones for walls.**

*Differenze tra le temperature teoriche e quelle reali per pareti.*

rods holding ceramic anchor;

- Li1  $\diamond$  Temperature behaviour near to ceramic anchor (temperature increased by 50% compared to the calculated theoretical temperature).

Thermography of fumes duct (Fig. 21) highlights the following factors

- Sp1=115,5°C  $\diamond$  External temperature near metallic anchor;

- Sp2=99,8°C  $\diamond$  External temperature at point of maximum insulation;

- Li1  $\diamond$  Temperature flow at hypothetical line linking different metallic anchor. In this instance temperature increase by 15% in proximity of thermal bridge.

The following Tab. 3 and Tab. 4 analyze the different theoretical temperatures and the real ones for both linings.

## CONCLUSIONS

Thermal bridges strongly influence the actual shell temperature (+15÷20%); we can resolve this phenomenon only partially by enlarging as much as possible the anchor pitch or by adopting alternative solutions such as prefabricated blocks linings. However thermal bridges cannot be eliminated but only reduced.

Other corrective action beside the above are the increase of thickness of insulating layers, the use of more performing insulating materials with unavoidable consequence of higher costs or the use of externally cooled systems (water or air cooled).

In light of the results of this study furnace builder should perform a detailed analysis prior specifying the guaranteed temperature values.

---

## ABSTRACT

---

### **L'INFLUENZA DEI PONTI TERMICI NELLE MURATURE REFRATTARIE**

*Parole chiave: acciaio inox, refrattari, ossidazione, saldatura*

*In questa memoria viene analizzata l'influenza dei ponti termici, originati dalla presenza dei sistemi di ancoraggio nelle murature verticali e nei rivestimenti orizzontali (volta, suole).*

*L'engineering, ed in particolar modo i calcoli termici, permettono di deter-*

*minare preventivamente l'isolamento più idoneo possibile delle murature. L'esigenza di ottenere il raggiungimento di valori "garantiti" è però molto spesso deviata da considerazioni incomplete.*

*Attraverso l'utilizzo della termografia viene effettuata una dettagliata analisi pendendo come esempio impianti funzionanti al fine di evidenziare i parametri che concorrono alla reale determinazione del risultato al fine di selezionare un range di scostamento dal calcolo teorico.*

*Azioni correttive insieme a considerazioni finali sono esposte con l'ausilio di disegni, foto ed analisi termografiche.*