



## Investigation on the static and dynamic structural behaviors of a regional aircraft main landing gear by a new numerical methodology

F. Caputo, A. De Luca, A. Greco

*Department of Industrial and Information Engineering, University of Campania "L. Vanvitelli", Via Roma 29, 81031 Aversa, Italy.*

*francesco.caputo@unicampania.it, alessandro.deluca@unicampania.it, alessandro.greco@unicampania.it*

S. Maietta

*Department of Industrial Engineering, Università degli Studi di Napoli Federico II, Naples, Italy.*

*smaietta@unina.it*

A. Marro, A. Apicella

*Magnaghi Aeronautica, Via Galileo Ferraris, 76, 80142, Naples, Italy*

*amarro@magnaghiaeronautica.it, aapicella@magnaghiaeronautica.it*

**ABSTRACT.** In this paper, a new methodology supporting the design of landing gears is proposed. Generally, a preliminary step is performed with simplified FE model, usually one-dimensional, to achieve the reaction forces involving each component during all aforementioned aircraft operations. Though this approach gives a valid support to the designer, it is characterized by several problems, such as the related approximations. So, it is important, by a numerical point of view, to develop an isostatic FE model equivalent to the real one. In fact, if the landing gear is modelled as hyperstatic, the static equilibrium equations are insufficient for determining the internal forces and reactions on each sub-component; so, the modelled material properties and geometries assume an increasing importance, which gets the model too approximating.

The proposed methodology consists of achieving the reaction forces by means of multibody simulations, by overcoming such problems, since each component is modelled as rigid. In this paper, also a FE model for the investigation of the structural response is proposed. Aimed to Certification by Analysis purposes, the developed multibody and the FE models have been assessed against an experimental landing gear drop test carried out by Magnaghi Aeronautica S.p.A., according to the EASA CS 25 regulations.

**KEYWORDS.** Landing gear; Multibody; FE analysis; Dynamic behaviour; Drop Test.



**Citation:** Caputo, F., De Luca, A., Greco, A., Maietta, S., Marro, A., Apicella, A., Investigation on the static and dynamic structural behaviors of a regional aircraft main landing gear by a new numerical methodology, *Frattura ed Integrità Strutturale*, 43 (2018) 191-204.

**Received:** 27.11.2017

**Accepted:** 05.12. 2017

**Published:** 01.01.2018

**Copyright:** © 2018 This is an open access article under the terms of the CC-BY 4.0, which permits unrestricted use, distribution, and reproduction in any medium, provided the original author and source are credited.

## INTRODUCTION

The design of the landing gear, according to the Airworthiness Regulations [1, 2], must take into account several requirements in terms of safety, strength, stability, etc. under all possible in-service loading conditions (weather conditions included). The landing gear is one of the main structural components characterizing an aircraft. It is aimed to support the aircraft during the landing, the tacking off and ground operations. Among such loading conditions, the landing phase defines the design specifications, since it is the most burdensome. As a result, such loading condition determines its structural size.

As matter of the fact, a landing gear can be considered as an aircraft subsystem characterized by such subcomponents as brake, wheels, tyres, shock absorber and some structural kinematic components aimed to the extraction and retraction of the landing gear. The last two sub-components play an important role during the flight. In fact, the landing gear dimensions are such to get it so bulky to increase significantly the drag coefficient. Hence, it is important to retract it during the flight.

An important aspect to take into account during the design phase is the landing gear weight which may reach up to the 3% of the maximum aircraft weight during the taking off.

Hence the design phase of the landing gear has a heavy impact on the whole structure and on the airplane aerodynamic. For these reasons, it is developed contextually to the aircraft design phase.

The landing gear development involves the use of standardized and ad-hoc components which must guarantee its kinematic, rather than the resistance to the static and dynamic loading conditions, such as the ground operations (taxing, towing, steering, etc...) and the taking off and the landing phase (vertical load, spin up, spring back, etc...).

In literature, several works have been addressed to the investigation of landing gear performances as well as other aircraft structural components under the dynamic loads produced by a landing operation [3-10]; the State of the Art sees also the use of numerical models for landing gear design purposes. For example, Infante et al. [11] presented a detailed analysis of a nose landing gear failure, supported by FE analyses. The investigation focused on an accident in which the nose of the landing gear fork of a light aircraft failed during landing. Mohammed et al. [12], in their work, focused on the structural components, made of composite materials, of a landing gear. Structural safety for static and spectrum loads is analysed using ANSYS.

Numerical methods are not only used for structural purposes. Redonnet et al. [13] proposed a numerical characterization of the aeroacoustics by a simplified nose landing gear, through the use of advanced simulation and signal processing techniques. To this end, the NLG noise physics is first simulated through an advanced hybrid approach, which relies on Computational Fluid Dynamics (CFD) and Computational AeroAcoustics (CAA) calculations.

Viúdez-Moreiras et al. [14] investigated on the dynamic loads affecting main landing gear doors of an Airbus passenger aircraft. Currently, significant budget is invested by manufacturers in order to test the aerodynamic performance and the high costs associated to wind tunnel and flight testing restrict the number of test cases that can be performed. So, the authors proposed a numerical model for the unsteady aerodynamics characterized by wind tunnel testing, in order to predict the aerodynamic effect in previously untested conditions, and in this way, to allow a first stage exploration of new areas in the design space, without the need of expensive wind tunnel or flight testing.

Concerning the landing gear structural investigation, generally, in the aircraft field, a preliminary step is performed with simplified FE model. Such numerical model, usually one-dimensional, is adopted to achieve the reaction forces involving each component during all aforementioned aircraft operations. After that, the design of each sub-component is carried out through detailed structural FE analyses where, once at time, each component, modelled with three-dimensional finite elements, is assembled into a one-dimensional FE model (stick model) representing the whole landing gear under the investigated operation. The reaction forces achieved by means of the multibody analysis will be applied statically to the stick FE model and, then, to each sub-component.

In this paper, a new methodology is proposed. Such method allows achieving, by means of multibody simulations, rather than the reaction forces involving each sub-component, the kinematic response of whole landing gear, the coherence of the spatial dimensions of each sub-component, which should not impede the motion of another one, and the dynamic behaviour such as the in-play mass values, the equivalent stiffness and the damping coefficients of the landing gear components.

Even though this approach gives a valid support to the designer during a preliminary design phase, the stick model technique is characterized by several problems, such as the approximations in the geometry modelling. Moreover, according to such approach, it is important, by a numerical point of view, to develop an isostatic FE model equivalent to the real one. In fact, if the landing gear is modelled as hyperstatic, the static equilibrium equations are insufficient for



determining the internal forces and reactions on each sub-component; so, the modelled material properties and geometries assume an increasing importance, which gets the stick model a solution too approximating. Moreover, the multibody analysis can be coupled with a three-dimensional Full-FEM analysis for the investigation of the landing gear behaviour under dynamic loading conditions, such as the drop test carried out according to the EASA CS 25 regulations [1]. Therefore, this numerical methodology, under Certification by Analysis (CbA) point of view, can be used to test virtually new structural solutions, by reducing the high experimental costs.

These numerical analyses have been carried out in order to investigate the main landing gear of a regional airliner. The numerical results of the dynamic analysis have been compared with the experimental ones supplied by Magnaghi Aeronautica S.p.A. Company and good agreement has been achieved.

### TEST ARTICLE

The main landing gear of a regional airliner has been investigated (Fig. 1). The material properties of the landing gear components are shown in Tab. 1.

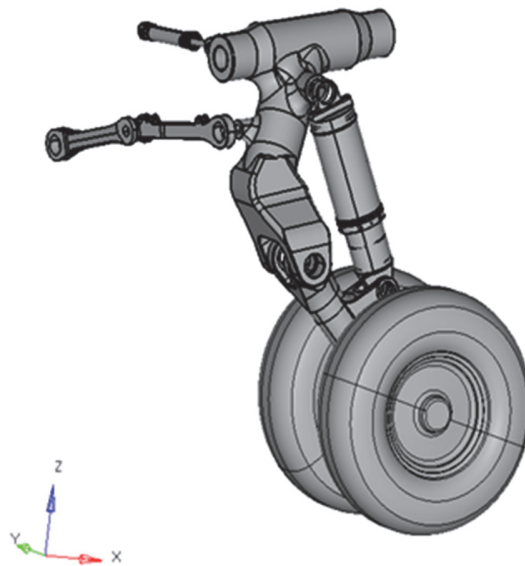

Figure 1: Main Landing Gear.

Wheel axle	300M AMS6257
Main fitting/ Trailing Arm	AL7175-T74 AMS 4149
Folding Side Brace	Ti6Al4V AMS4928
Shock Absorber Cylinder	4340 AMS 6414

Table 1: Material properties.

### STATIC FE ANALYSIS

The stick model of the landing gear is shown in Fig. 2.

A total of 40 nodes and 42 finite elements have been used. Concerning the boundary conditions, the stick model has been constrained as shown in Fig. 3.

The stick model of the main landing gear has been investigated by considering an attitude, under static loading condition, of 75% of the total shock absorber mechanical stroke. The considered loading condition is characterized by two vertical forces of 78800 N applied to the centre of wheels (Fig. 3). The reaction forces achieved by the FE analysis have been reported in Section 4 and compared with those achieved by the multibody analysis.

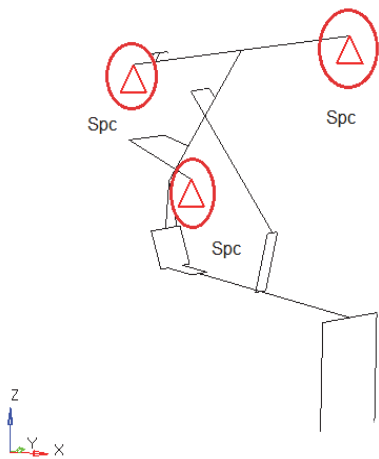

Figure 2: Stick model of the landing gear.

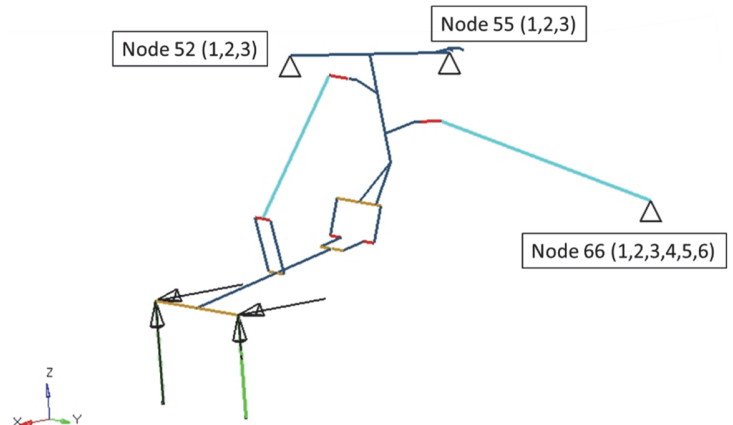

Figure 3: Boundary conditions.

### STATIC MULTIBODY ANALYSIS

As aforementioned, the multibody analysis allows investigating the kinematic and dynamic behaviours of the investigated main landing gear. Thanks to such analysis, it has been possible to understand the trajectory of the landing gear subcomponents and the reaction forces acting on them as a function of the time.

A multibody analysis is, for such reasons, often used to understand the kinematic of each sub-component, before the landing gear manufacturing.

The multibody analysis carried out in this work has been developed in Adams® software environment [15]. The components have been modelled as rigid and linked reciprocally by means of ideal constrains, without considering their elasticity and the related friction.

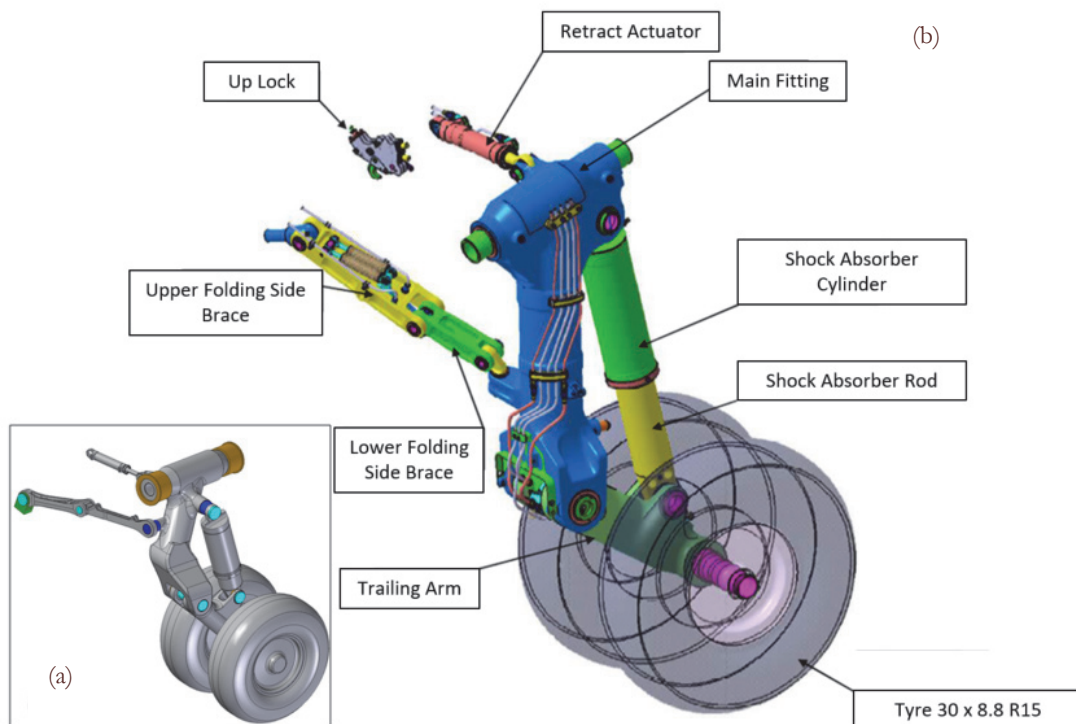

Figure 4: Landing gear: a) Multibody model; b) main structural components.

The inertia properties are automatically considered in the developed model by introducing the density in the material properties.

The multibody model (Fig. 4.a) has been developed in order to reproduce the landing gear schematically shown in Fig. 4.b.

According to Fig. 4.b, the model is characterized by two tyres, two wheels, a wheel axle, a shock absorber, a main fitting, a trailing arm, an actuating cylinder, an upper folding side brace and a lower folding side brace.

Different joint types have been introduced in the model: revolute joints, allowing the motion between the trailing arm, the main fitting and the shock absorber (Fig. 4.b); revolute joints modelled between the folding side brace, the main fitting and the support fixture (not visible in Fig. 4 - modelled at the left end of the upper folding slide brace) (Fig. 5.a); prismatic joints, allowing the sliding between the piston and the cylinder tube of the shock absorber.

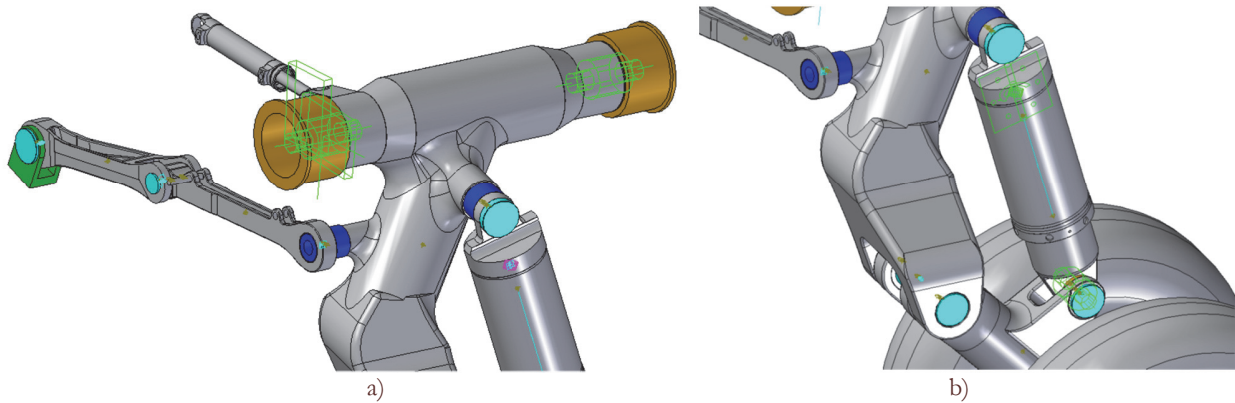

Figure 5: Revolute joints between: a) main fitting and the support fixture; b) main fitting, trailing arm and shock absorber.

The considered loading conditions are characterized by two vertical forces of 78800 N applied to the wheels, by assuming a shock absorber stroke of 75% of total mechanical stroke.

The results, in terms of reaction forces, have been compared with those achieved by the stick model under the same loading conditions.

Tabs. 2.a and 2.b show the reaction forces achieved by the multibody and the stick (FE) model, respectively.

a) Node 52						b) Node 52					
Rx	Ry	Rz	Mx	My	Mz	Rx	Ry	Rz	Mx	My	Mz
[N]	[N]	[N]	[Nmm]	[Nmm]	[Nmm]	[N]	[N]	[N]	[Nmm]	[Nmm]	[Nmm]
25293	3453	-16000.3	0	0	0	25290	3463	-16000	0	0	0
Node 55						Node 55					
Rx	Ry	Rz	Mx	My	Mz	Rx	Ry	Rz	Mx	My	Mz
[N]	[N]	[N]	[Nmm]	[Nmm]	[Nmm]	[N]	[N]	[N]	[Nmm]	[Nmm]	[Nmm]
17395	-261989	54479	0	0	0	17390	-262000	54490	0	0	0
Node 66						Node 66					
Rx	Ry	Rz	Mx	My	Mz	Rx	Ry	Rz	Mx	My	Mz
[N]	[N]	[N]	[Nmm]	[Nmm]	[Nmm]	[N]	[N]	[N]	[Nmm]	[Nmm]	[Nmm]
-42688	258536	-52077	0	0	0	-42690	258500	-52080	0	0	0

Table 2: Reaction forces achieved for the main landing gear by the a) multibody and b) stick models.

According to Tabs. 2.a and 2.b, a good agreement has been achieved.

## DYNAMIC ANALYSIS

On the basis of the static analysis described in the previous sections, the development of the Full-FE model, characterized by all landing gear sub-components modelled with three-dimensional finite elements, has been developed in Ls-Dyna® [16] software environment (Fig. 6). The model counts a total of 448833 nodes and 1222240 of three-dimensional finite elements.

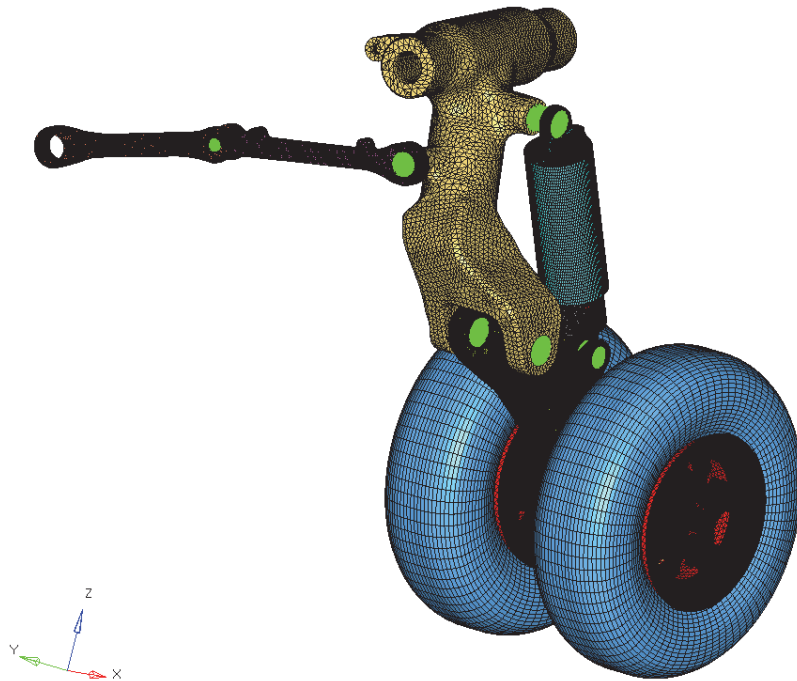

Figure 6: FE model.

Because of the complexity of the analysis, the modelling of landing gear has been carried out step-by-step, starting from the modelling of the shock absorber, to the modelling of the contacts and constrains between the sub-components, to the material properties (non-linear) and the tyre numerical characterization.

Joints connection between the sub-components have been modelled by means of one-dimensional rigid finite elements, assembled together in order to simulate spherical and cylindrical joints.

For example, Fig. 7.a shows the spherical joints modelled between the main fitting and the shock absorber; Fig. 7.b shows the cylindrical joint modelled between the trailing arm and the shock absorber.

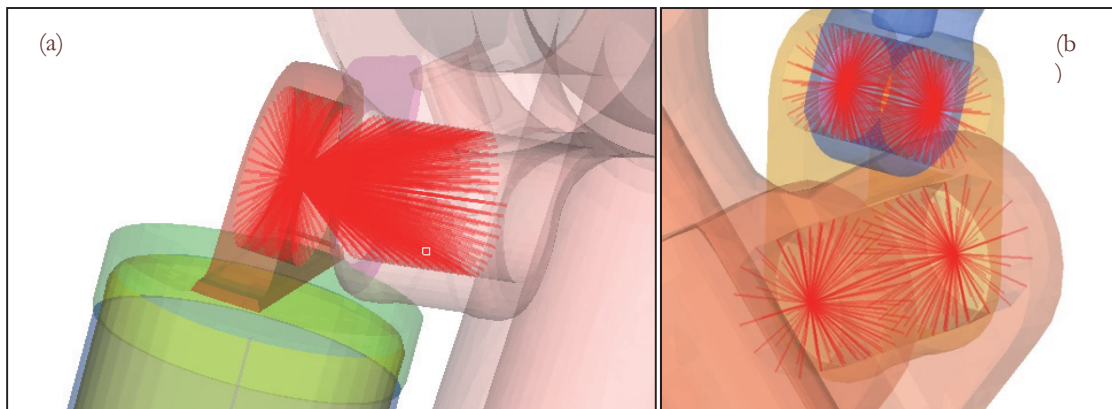

Figure 7: a) Spherical and b) cylindrical joints.



In order to ensure the motion between the main fitting and the trailing arm a cylindrical pin has been modelled as shown in Fig. 8.

In order to enable the model to simulate the sliding of the piston inside the cylinder tube, a contact surface has been modelled between them. A “contact-automatic-surface-to-surface-offset” algorithm has been defined; in particular, a master surface has been defined around the piston and a slave one inside the cylinder tube (Fig. 9). This type of contact algorithm allows modelling an offset between these two surfaces that will be kept constant during the sliding.

In order to simulate the sliding, since the forces at stake are significantly severe, also a cylindrical joint has been introduced in the shock absorber constraining the piston to slide axially inside the cylinder tube (Fig. 9).

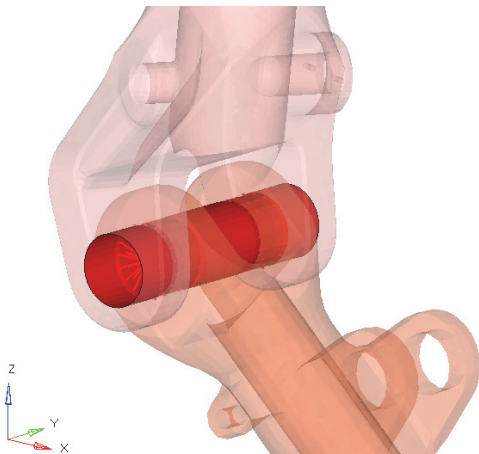

Figure 8: Pin linking the main fitting and the trailing arm.

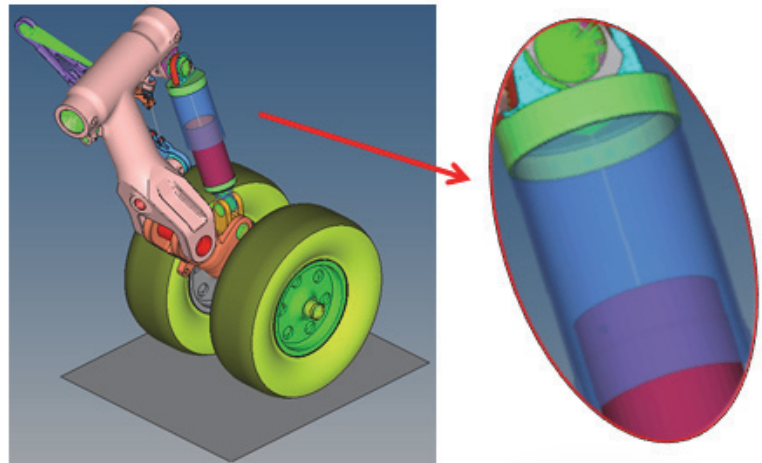

Figure 9: Modelling of the shock absorber.

In order to model the damping and elastic responses, the shock absorber has been modelled by placing a beam element between its ends. Such beam element allowed introducing the non-linear spring and damping properties characterizing the shock absorber. These non-linear properties have been modelled by setting a particular material card allowing the definition of the spring polytrophic curve (Fig. 10) and the damping factor, set equals to 150 kNms/mm.

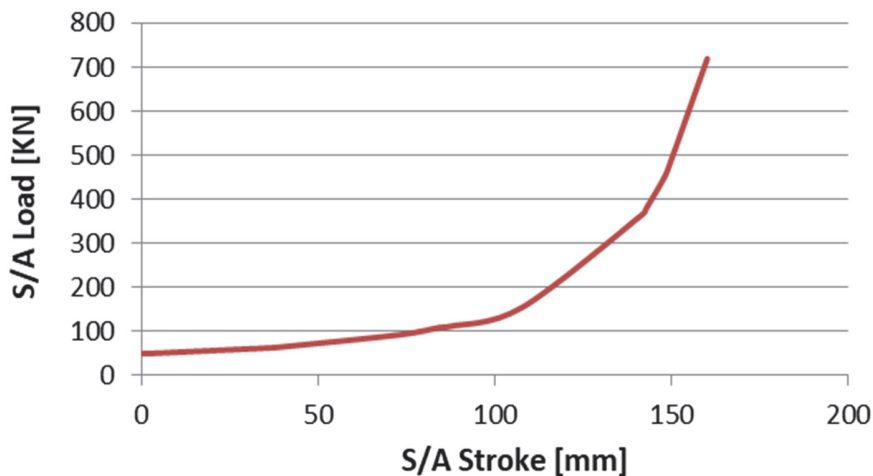

Figure 10: Polytrophic curve.

Moreover, differently from the stick model, in order to increase the landing gear stability during the drop test, the secondary actuation system has been modelled (Fig. 11) by introducing an elastic and a viscous finite element, characterized by a constant elastic stiffness and a damping factor of 50 kN/mm and 50 kN·ms/mm, respectively.

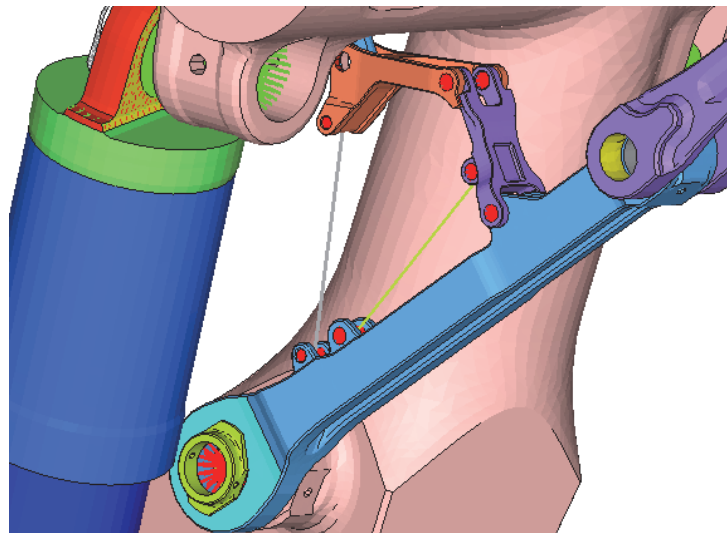

Figure 11: Secondary actuation system.

Another constraint type, shown in Fig. 12, has been defined in order to ensure the motion between the wheels and the axle.

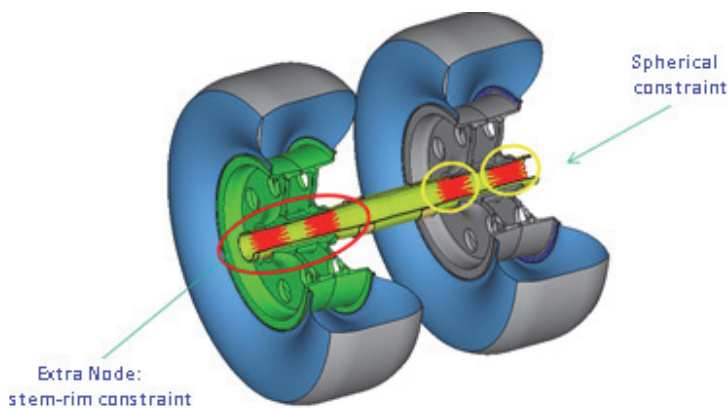

Figure 12: Modelling of the joints between wheels and axle.

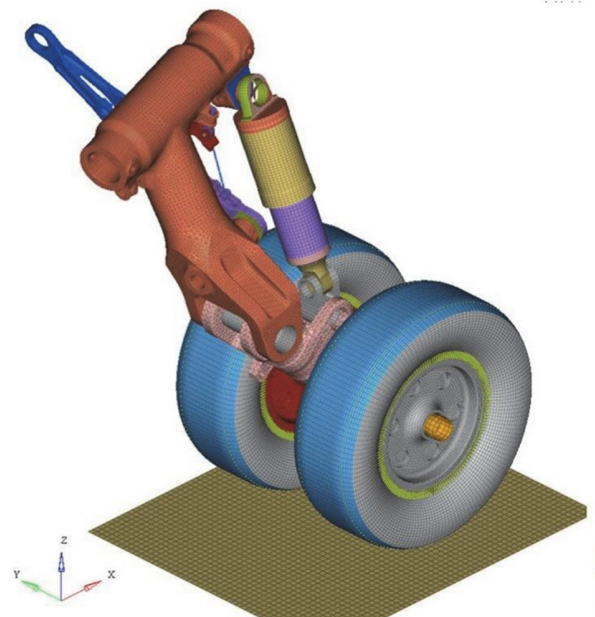

Figure 13: Modelling of the rigid wall.

A rigid wall (Fig. 13), representing the ground, has been also modelled in order to simulate the drop test. Also here, “contact-automatic-surface-to-surface” algorithm has been defined between the rigid wall and the tyres. In order to simplify the drop test simulation, the landing gear has been fully constrained; whilst the rigid wall has been constrained in a way to enable its motion only along the drop test axis (z-axis).

Concerning the modelling of the tyre, the same technique used to model the airbag in the automotive field, has been used. It is, in fact, an efficient method, usable to model the tyres.

Such modelling started to the definition of a closed surface containing a control volume (Fig. 14). Such volume represents the tyre tube which has been numerically inflated by introducing a mass flow rate up to reach the desired pressure value (8.5 bar).



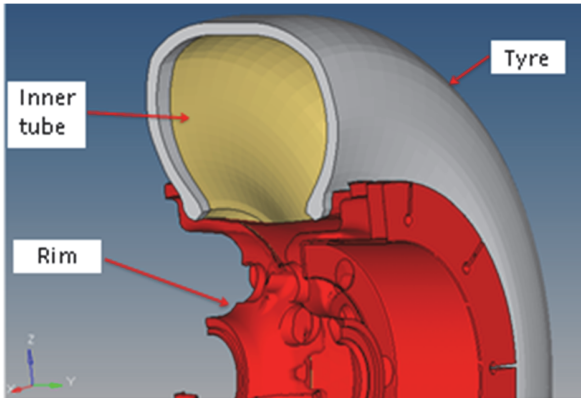

Figure 14: Modelling of the tyre.

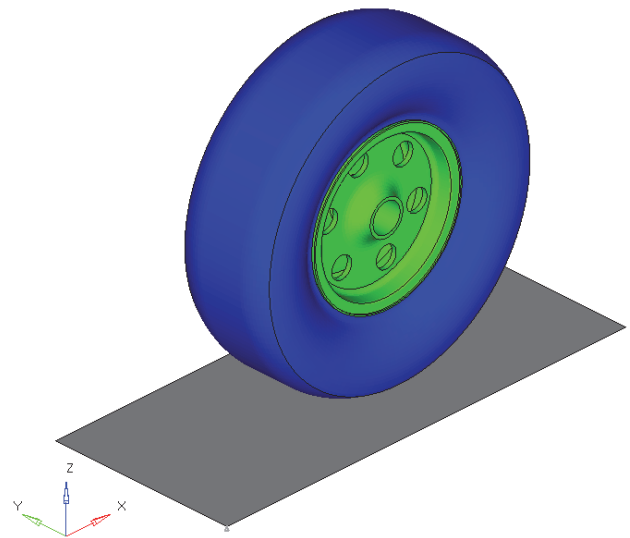

Figure 15: Wheel/rigid wall subsystem.

In order to simulate properly the tyre behaviour, the material properties of the rubber have been modelled in order to replicate the experimental response of a tyre similar to the investigated one. In particular, such response consists of measuring the tyre deflection under an increasing vertical force. In order to do this, a FE analysis involving only the wheel-rigid wall system has been considered (Fig. 15). Fig. 16 shows the numerical-experimental correlation of the vertical force vs. the measured tyre deflection curves.

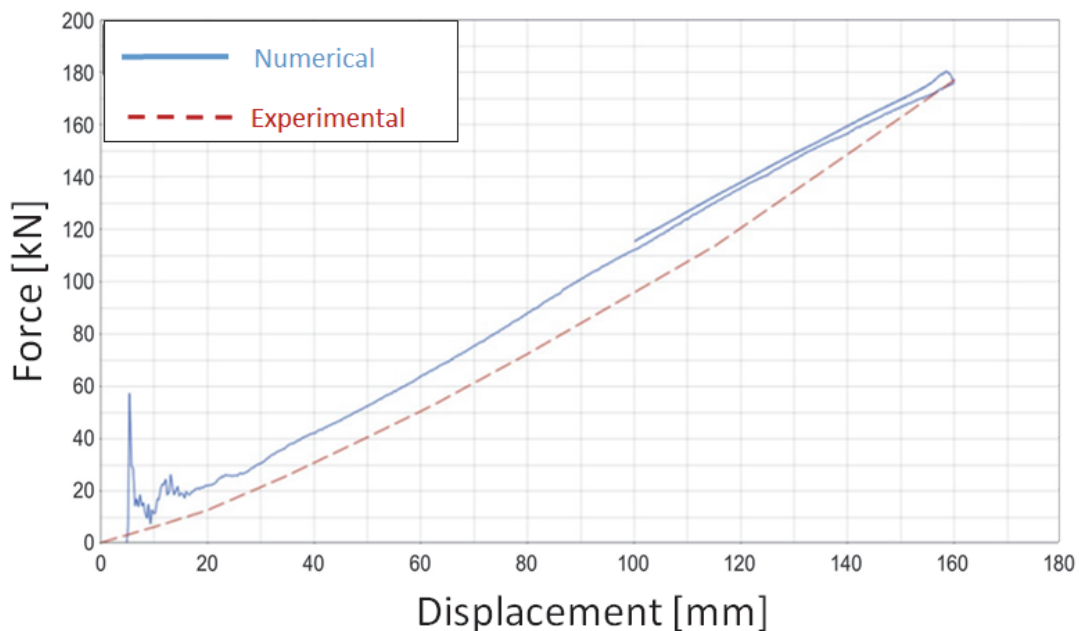

Figure 16: Numerical and experimental vertical forces vs. tyre deflection.

According to Fig. 16, it can be noticed that the numerical model overestimates the experimental response. This can be attributed to the fact that the experimental response, found in literature, is referred to a tyre (H34 x 10R16) which is slightly smaller than the investigated one (H30 x 8.8 R15). However, the tyre modelling can be considered efficient. The difference, in terms of percentage, has been calculated to be around 10%.

After the numerical tyre characterization, the entire landing gear has been constrained in order to reproduce the drop-test described by the EASA CS25 regulations. Such regulations define all test requirements, included the calculation of the equivalent airplane mass resting on the landing gear to be implemented during the test. The modelled mass assumes a value of 10800 kg and it has been added to the rigid wall.

In order to get simpler the numerical simulation, as aforementioned, the landing gear has been fully constrained, whilst the rigid wall has been constrained in a way to allow the motion along the z-axis (Fig. 17), representing the gear drop axis.

A drop velocity of 3.05 m/s has been applied to the rigid wall. Moreover, a rotational speed of 44.64 m/s has been applied to the wheels. A pitch angle of  $0^\circ$  has been considered.

The dynamic simulation has been carried out by setting an analysis time of 450 ms, by leaving the estimation of the time increment to the software. However, in complex simulations, the time increment can reach values too small that increase sharply the computational costs. In order to avoid such problems, an artificial mass can be added to the model in a way that the whole model mass does not reach the 8÷9 %.

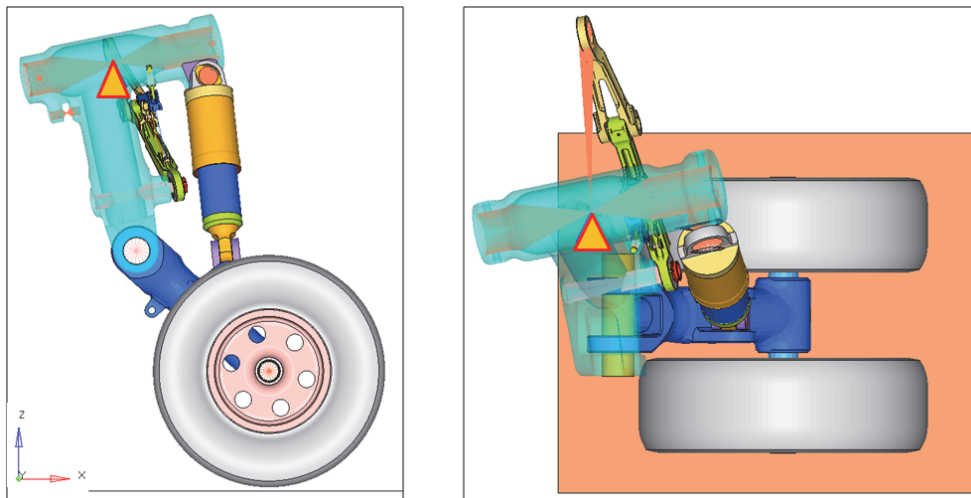

Figure 17: Landing gear model.

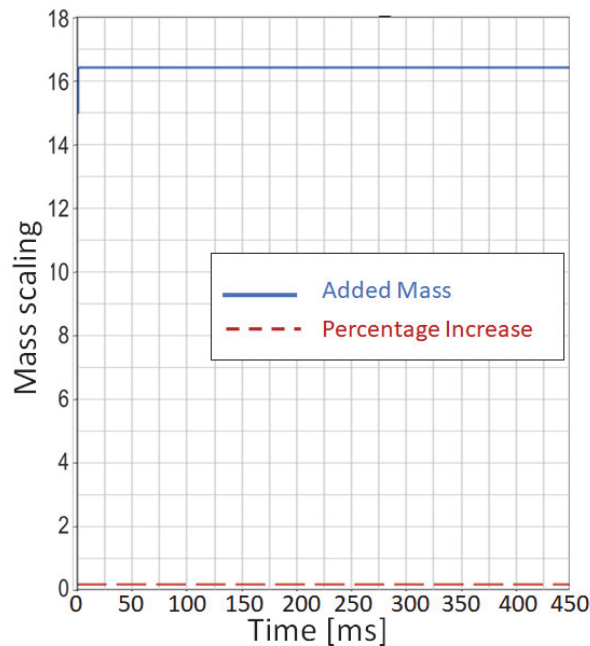

Figure 18. Added mass curve.



## NUMERICAL-EXPERIMENTAL RESULTS

In order to save the computational costs an artificial mass has been added to the model in a way that the whole model mass does not reach the 8±9%, as shown in Fig. 18.

Fig. 19 shows the energies balance. In particular, kinetic, hourglass, interface, internal and total energies are shown. According to Fig. 19, the kinetic and internal energies are characterized by two analogous picks. Such picks are due to the fluctuation of the tyre inflation. The hourglass energy is null for all the analysis.

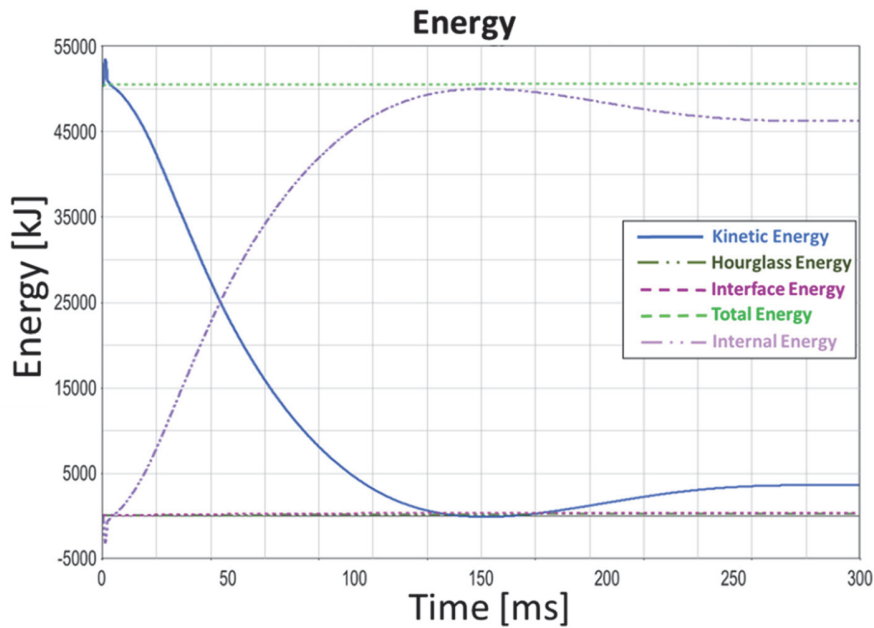

Figure 19: Energies balance.

Also the tyre inflation has been monitored by plotting the tyre tube pressure as a function of the analysis time (Fig. 20.a). It can be noticed that the pressure starts by a value of 0 and reaches instantly the reference value of 8.5 bar. Fig. 20.b shows the volume of the tyre tube during the drop test simulation.

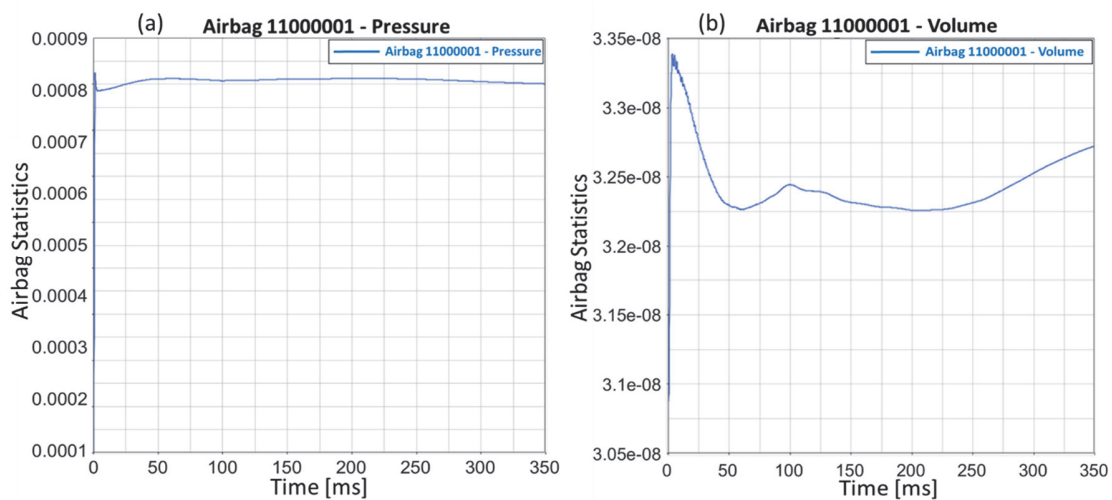

Figure 20: a) Pressure and b) volume tyre tube vs. time.

The assessment of the prediction capability of the performed simulations has been carried out, first of all, by comparing the numerical and experimental shock absorber stroke vs. rigid wall displacement curves (Fig. 21.a). The numerical results have been compared with the results achieved by two experimental tests, carried out with pitch angles of  $0^\circ$  and  $5.94^\circ$ , respectively.

According to Fig. 21.a, the numerical curve fits properly the experimental curve related to the  $0^\circ$  pitch angle up to a wheel displacement of 250 mm; after that, the numerical curve slope decreases and the curve fits better the experimental one related to a  $5.95^\circ$  pitch angle. As a result, a good agreement has been achieved. Figs. 21.b and 21.c show the stroke and the rigid wall displacement vs. time curves, respectively.

The numerical contact force between tyres and the rigid wall has been illustrated in Fig. 22.

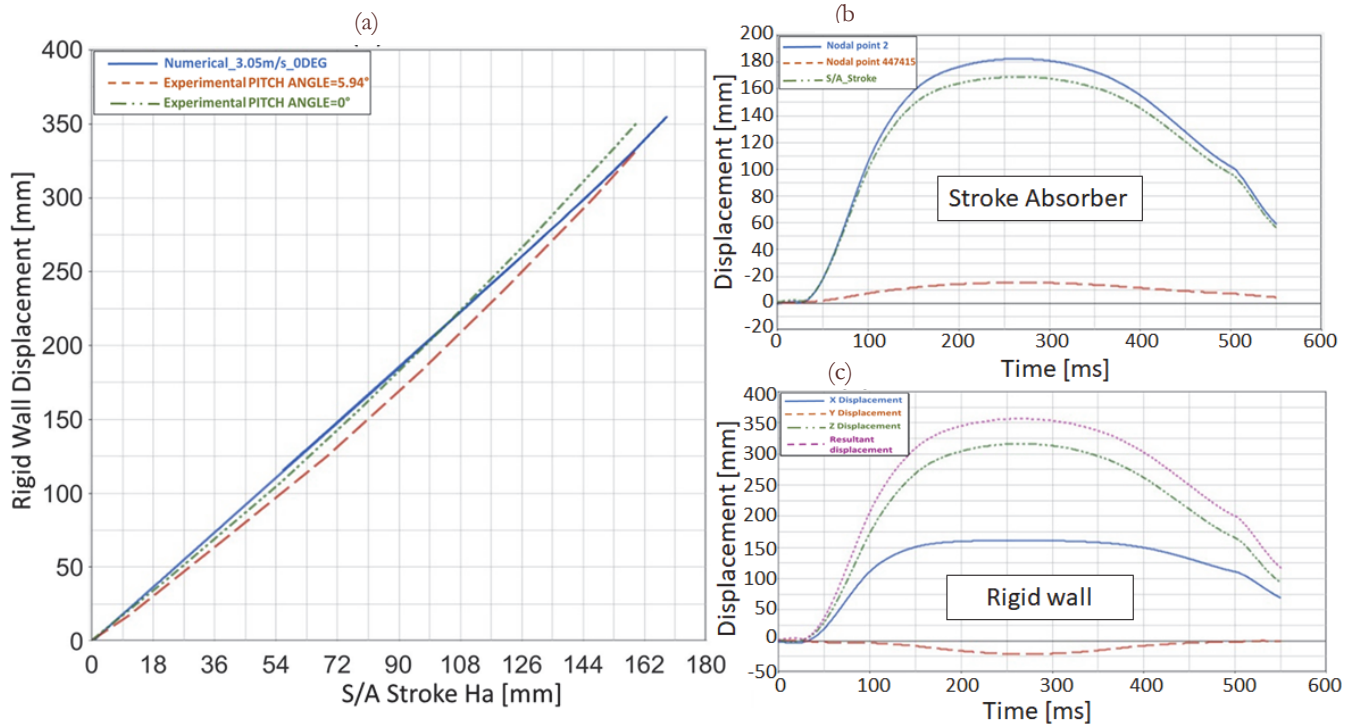

Figure 21: a) Shock absorber stroke vs. rigid wall displacement curves; b) shock absorber stroke vs. time curves; c) rigid wall displacement vs. time curves.

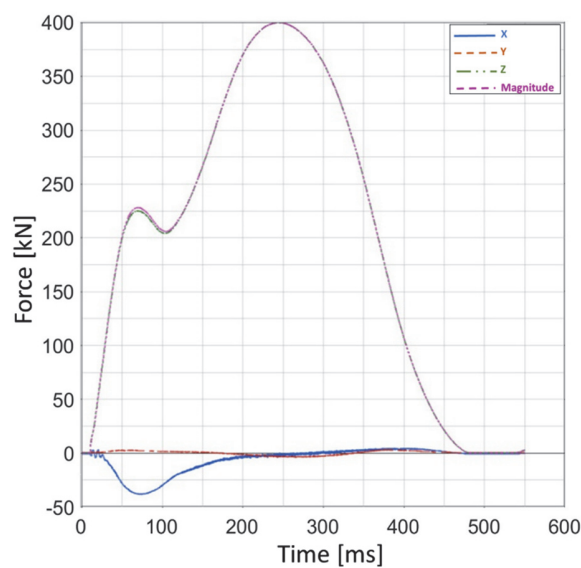

Figure 22: Contact force between tyres and rigid wall.



The numerical and experimental shock absorber reactions have been plotted as a function of the stroke in Fig. 23.a. Finally, the numerical contact force between the wall and tyres has been compared with the respective experimental one as a function of the wall displacement in Fig. 23.b.

According to Fig. 23, a good agreement has been achieved between numerical and experimental results.

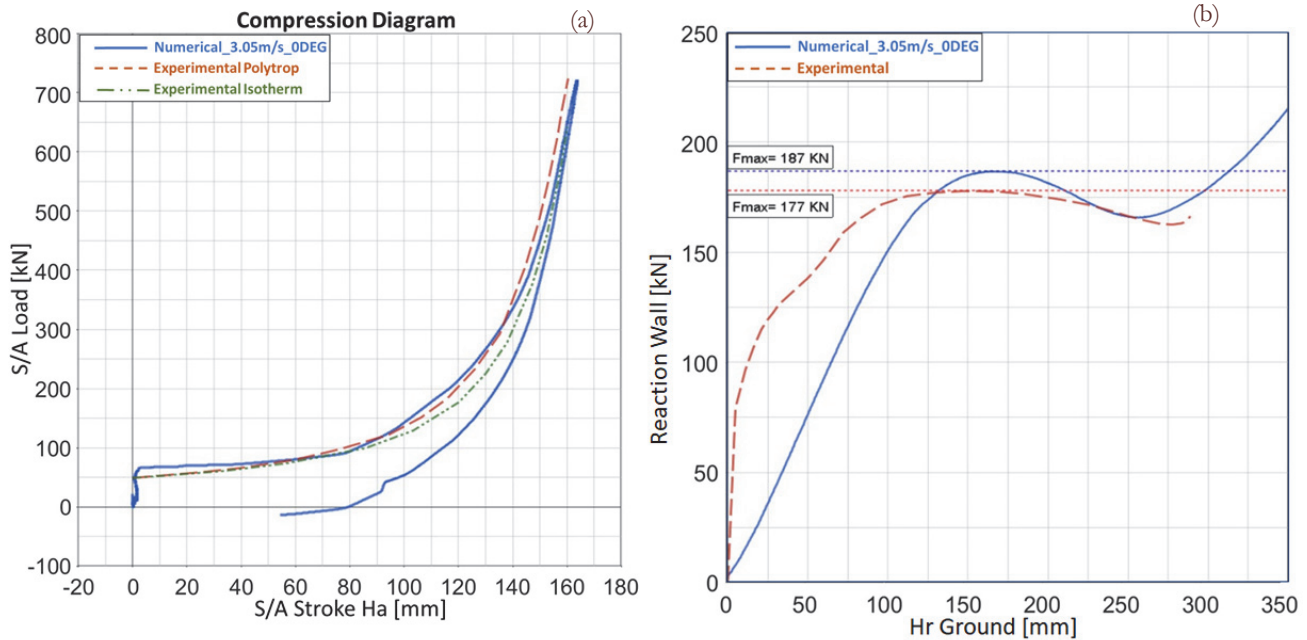

Figure 23: a) Shock absorber reaction vs. stroke curves; b) reaction between tyres and rigid wall vs. wall displacement curves.

## CONCLUSIONS

In this paper, a new methodology supporting the design phase of the landing gear is proposed. Such method allows achieving, by means of multibody simulations, rather than the reaction forces involving each sub-component, the kinematic response of whole landing gear, the coherence of the spatial dimensions of each sub-component, which should not impede the motion of another one, and the dynamic behaviour such as the in-play mass values, the equivalent stiffness and the damping coefficients of the landing gear components.

Moreover, the multibody analysis can be coupled with a three-dimensional Full-FEM analysis for the investigation of the landing gear behaviour under dynamic loading conditions, such as the drop test carried out according to the EASA CS 25 regulations. Therefore, this numerical methodology, under Certification by Analysis (CbA) point of view, can be used to test virtually new structural solutions, by reducing the high experimental costs,

These numerical analyses have been carried out in order to investigate the main landing gear of a regional airliner. The numerical results of the dynamic analysis have been compared with the experimental ones supplied by Magnaghi Aeronautica S.p.A. and good agreement has been achieved.

## ACKNOWLEDGMENTS

The research activity has been developed within CAPRI – “Landing gear with intelligent implementation” Research Project founded Regione Campania, Italy.

## REFERENCES

- [1] Certification Specifications and Acceptable Means of Compliance for Large Aeroplanes CS-25 EASA: European Aviation Safety Agency.



- [2] Federal Aviation Regulations FAR25.
- [3] Williams, D., Jones, R.P.N., Dynamic Loads in Aeroplanes under Given Impulsive Loads with Particular Reference to Landing and Gust Loads on a Large Flying Boat, Britain: Aeronautical Research Council; (1948) TR No. 2221.
- [4] McPherson, A.E., Evans, Jr. J., Levy, S., Influence of Wing Flexibility on Force-Time Relation in Shock Strut Following Vertical Landing Impact, Washington, (1949), NACA TN 1995.
- [5] Cook, F.E., Milwitzky, B., Effect of Interaction on Landing-Gear Behaviour and Dynamic Loads in a Flexible Airplane Structure, United States, (1956), NACA TR 1278.
- [6] Luber, W.G., Dill E., Kainz, K., Dynamic landing loads on combat aircraft with external stores using finite element models, in: IMAC-XXV: Conference and Exposition on Structural Dynamics, Orlando, FL (2007) 19–22.
- [7] Pérez, J.L., Benítez, L.H., Oliver, M., Climent, H., Survey of aircraft structural dynamics nonlinear problems and some recent solutions, *Aeronaut. J.* 115 (1173) (2011) 653–668. DOI: 10.1017/S0001924000006382.
- [8] Suresh, P., Nesar, S., Radhakrishnan, G., Dynamic landing response analysis of a flexible tailless delta wing aircraft, *Int. J. Aerosp. Innov.* 4 (3–4) (2012) 103–117. DOI: 10.1260/1757-2258.4.3-4.103.
- [9] Chester, D.H., Aircraft landing impact parametric study with emphasis on nose gear landing conditions, *J. Aircr.* 39 (3) (2002) 394–403. DOI: 10.2514/2.2964.
- [10] Lomax, T.L., Structural Loads Analysis for Commercial Aircraft: Theory and Practice, AIAA Education Series (1996). ISBN-13: 978-1563471148.
- [11] Infante, V., Fernandes, L., Freitas, M., Baptista, R., Failure analysis of a nose landing gear fork, *Eng. Fail. Anal.*, 82 (2017) 554-565. DOI: 10.1016/j.engfailanal.2017.04.020.
- [12] Imran, M., Ahmed, R.M. S., Haneef, M., FE Analysis for Landing Gear of Test Air Craft, *Mater. Today*, 2 (4-5) (2015) 2170-2178. DOI: 10.1016/j.matpr.2015.07.228.
- [13] Redonnet, S., Ben Khelil, S., Bulté, J., Cunha, G., Numerical characterization of landing gear aeroacoustics using advanced simulation and analysis techniques, *J. Sound. Vib.*, 403 (2017) 214-233. DOI: 10.1016/j.jsv.2017.05.012
- [14] Viúdez-Moreiras, D., Martín, M., Abarca, R., Andrés, E., Ponsín, J., Monge, F., Surrogate modeling for the main landing gear doors of an airbus passenger aircraft, *Aerosp. Sci. Technol.*, 68 (2017) 135-148. DOI: 10.1016/j.ast.2017.04.021
- [15] ADAMS User Reference Manual 2015, MSC Software Corporation.
- [16] Hallquist, J.O., *LS-DYNA theory manual* (2006). ISBN 0-9778540-0-0.