

Evaluating Last-Mile Hazard Information Dissemination: A Research Proposal

(HazInfo Project)

Grant No.: 103553-001

Grant Period: 01-December-2006 to 31-March-2008

Report Presentation Date: 10-March-2008



Submitted to IDRC by:

LIRNEasia

12 Balcombe Place

Colombo 8 Sri Lanka

Tel: +94 114 939 992 Fax: +94 112 675 212

E-mail: samarajiva@lirne.net

Web site: www.lirneasia.net

SRI LANKA

TABLE OF CONTENT

LIST OF TABLES.....	8
LIST OF FIGURES.....	10
1. SYNTHESIS.....	12
2. RESEARCH PROBLEM.....	13
2.1 PROJECT OBJECTIVE.....	13
2.2 PROJECT BACKGROUND.....	13
2.3 COMMENTS ON THE PROPOSED RESEARCH	14
3. RESEARCH FINDING.....	15
3.1 PERFORMANCE OF THE ICTs AS A WARNING TECHNOLOGY.....	16
3.2 CONTRIBUTION OF THE TRAINING REGIME.....	18
3.3 CONTRIBUTION OF VILLAGE ORGANIZATIONAL DEVELOPMENT.....	23
3.4 GENDER SPECIFIC RESPONSE TO HAZARD MITIGATION ACTION.....	25
3.5 DEGREE OF INTEGRATION OF ICTs IN THE DAILY LIFE OF VILLAGES.....	25
3.6 LOCAL BARRIERS IN RESPONDING TO ALERTS	26
4. FULLFILLMENT OF PROJECT OBJECTIVES.....	28
5. PROJECT DESIGN AND IMPLEMENTATION	32
5.1 CONCEPT OF OPERATIONS	32
5.2 LM-HWS FIVE WIRELESS ICTs	33
5.3 ICT PARTNERS AND THEIR CONTRIBUTIONS.....	35
5.4 CAP GUIs AND CAP BROKER	36
6. PROJECT OUTPUT AND DISSEMINATION	37
6.1 INFORMATION SHARING AND DISSEMINATIONS.....	37
6.2 KNOWLEDGE CREATION.....	44
6.3 TRAINING.....	45
7. CAPACITY BUILDING.....	47
7.1 LOCAL RESEARCH AND DEVELOPMENT.....	47
7.2 HAZARD INFORMATION HUB MONITOR COURSE.....	47
7.3 VILLAGE TRAINING OF COMMUNITY FIRST-RESPONDERS	47

8. PROJECT MANAGEMENT	49
9. IMPACT	50
10. OVERALL ASSESSMENT	51
11. RECOMMENDATIONS	52
11.1. MESSAGE FORMATTING - THE HHH AND THE GOVERNMENT	52
11.2. FURTHER TEST ICT ASSESSMENT TOOLS AND METHODOLOGIES	52
11.3. TABLE TOP EXERCISE FOR SELECTED MEMBERS IN COMMUNITY	52
11.4. TRAINING AND CERTIFICATION OF HHH MONITORS	53
11.5. TRAINING OF ICT GUARDIANS	53
11.6. COMMUNITY-BASED EMERGENCY COMMUNICATIONS PLANNING AND TRAINING	53
11.7. CONTRIBUTION TO CAP RESEARCH THROUGH WORKING GROUPS	54
11.8. ENHANCE AND TEST ICTS WITH COMPLETE AND FULL CAP FEATURES.....	54
11.9. FREE AND OPEN SOURCE SOFTWARE CAP BROKER	55
11.10. CLOSED USER GROUP DIGITAL AUDIO BROADCASTING	56
12. TECHNICAL ANNEX 1: LIST ACRONYMS AND ABBREVIATIONS.....	58
13. TECHNICAL ANNEX 2: WHAT IS A COMMUNITY-BASED LM-HWS	60
14. TECHNICAL ANNEX 3: INTERNETWORKING PIPES, AND GATEWAYS.....	61
15. TECHNICAL ANNEX 4: RESEARCH MATRIX AND ICT ALLOCATIONS	63
16. TECHNICAL ANNEX 5: CALCULATING THE EFFICIENCY OF PROCESSES	64
17. TECHNICAL ANNEX 6: MEASURING EFFECTIVENESS OF THE HHH AND COMMUNITY	67
18. TECHNICAL ANNEX 7: CALCULATING RELIABILITY OF ICT	67
18.1. CERTAINTY OF MESSAGE RECEIPT	68
18.2. EFFICIENCY MEASURE OF TRANSMISSION	70
19. TECHNICAL ANNEX 8: MEASURING EFFECTIVENESS OF THE ICT.....	70
19.1. EFFECTIVENESS OF THE INDIVIDUAL ICTS	70
19.2. EFFECTIVENESS OF A COMBINATION OF ICTS.....	71
20. TECHNICAL ANNEX 9: FUZZIFICATION OF FULL CAP COMPLETENESS	71

20.1.	CAP PROFILE FOR SRI LANKA	71
20.2.	COMPULSORY ELEMENTS OF THE CAP PROFILE	72
20.3.	LANGUAGE DIVERSITY IN SRI LANKA	72
20.4.	MIX OF PICTORIAL, AUDIO AND TEXT COMMUNICATION MEDIUMS	73
21.	TECHNICAL ANNEX 10: FUZZIFICATION OF ALERTING PROCESS	74
21.1.	ACKNOWLEDGEMENT OF MESSAGE RECEIPT.....	75
21.2.	WAKEUP FUNCTION TO GAIN ATTENTION.....	75
22.	TECHNICAL ANNEX 11: FUZZIFICATION OF TWO-WAY COMMUNICATION... 76	
22.1.	BI-DIRECTIONALITY FOR UPSTREAM AND DOWNSTREAM COMMUNICATION	76
23.	TECHNICAL ANNEX 12: FUZZIFICATION OF ADOPTABILITY	77
23.1.	INTEGRATION OF ICT IN TO COMMUNITY DAILY LIFE	77
23.2.	TOTAL COST OF OWNERSHIP.....	77
24.	TECHNICAL ANNEX 13: FUZZIFICATION OF MINIATURERIZATION.....	79
24.1.	WEIGHT OF THE ENTIRE FUNCTIONAL UNIT.....	80
24.2.	VOLUME OF TERMINAL DEVICE AND PERIPHERALS	80
24.3.	LONGEVITY OF OPERATIONAL STATE.....	82
25.	TECHNICAL ANNEX 14: EXPECTED PERFORMANCE OF THE ICT	83
25.1.	WORLDSPACE ADDRESSABLE SATELLITE RADIO SYSTEM	83
25.2.	DIALOG DISASTER AND EMERGENCY WARNING SYSTEM.....	85
25.3.	SOLANA NETWORKS/INNOVATIVE TECHNOLOGIES VSAT/IPAS.....	89
25.4.	SRI LANKA TELECOM NOMADIC TELEPHONY SYSTEM.....	90
26.	TECHNICAL ANNEX 15: GUIDELINES FOR THE HII.....	93
26.1.	OVERVIEW	93
26.2.	THE LM-HWS AND ITS RESPONSIBILITIES FOR ISSUING ALERTS	94
26.3.	STAFFING AND TRAINING AT THE HII.....	96
26.4.	MONITORING	101
26.5.	ACTIVATION	103
26.6.	PROHIBITED PRACTICES	116
26.7.	TESTING	116
26.8.	ANNEX A: CONTACT INFORMATION.....	117

26.9.	ANNEX B: GUIDELINES FOR DOCUMENTING AN EOI.....	118
26.10.	ANNEX C: SECONDARY SOURCES FOR CONFIRMING EVENTS OF INTEREST.....	118
26.11.	ANNEX D: TELEPHONE “HOTLINE” NUMBER FOR CONTACTING THE HIH.....	119
26.12.	ANNEX F: CAP ALERT MESSAGE EXAMPLE.....	120
27.	TECHNICAL ANNEX 16: TRAINING – HAZARDS.....	121
27.1.	DEFINITION OF HAZARDS.....	121
27.2.	HAZARD EVENTS.....	122
27.3.	MULTIPLE HAZARDS.....	122
27.4.	THE RETURN PERIOD.....	122
27.5.	CLASSIFICATION OF HAZARDS.....	123
27.6.	MORE HAZARD TERMINOLOGY.....	124
27.7.	HAZARD IDENTIFICATION AND ASSESSMENT.....	125
28.	TECHNICAL ANNEX 17: TRAINING – VULNERABILITY AND RISK.....	131
28.1.	VULNERABILITY.....	131
28.2.	RISK.....	133
29.	TECHNICAL ANNEX 18: TRAINING – DISASTER MANAGEMENT.....	139
29.1.	DISASTER MANAGEMENT.....	139
29.2.	RISK MANAGEMENT.....	140
29.3.	PREVENTION.....	142
29.4.	CRISIS MANAGEMENT.....	142
29.5.	RESPONSE AND RELIEF.....	143
29.6.	REHABILITATION AND RECONSTRUCTION.....	143
30.	TECHNICAL ANNEX 19: TRAINING – PARTICIPATORY RURAL APPRAISAL TOOLS.....	144
30.1.	IMPORTANCE OF PARTICIPATORY TECHNIQUES.....	144
30.2.	PARTICIPATORY RURAL APPRAISAL.....	145
30.3.	AIMS OF PARTICIPATORY METHODS.....	145
30.4.	SCOPE OF PRA.....	145
30.5.	PARTICIPATORY COMMUNITY MONITORING AND EVALUATION.....	147
31.	TECHNICAL ANNEX 20: TRAINING – COMMUNITY PUBLIC AWARENESS	149

31.1.	DEFINITION OF SOCIAL CHANGE COMMUNICATION CAMPAIGN	149
31.2.	DEFINITION OF DISASTER RISK COMMUNICATION.....	150
31.3.	STEPS IN DRC.....	153
31.4.	BARRIERS TO MAKING CHANGE.....	153
31.5.	SOME DISTINCTIONS	154
31.6.	PARTNERSHIPS.....	154
31.7.	DRC BUDGET	155
32.	TECHNICAL ANNEX 21: TRAINING – EARLY WARNING.....	156
32.1.	CLASSIFICATION OF DISASTERS FOR EARLY WARNING ACTIVITIES	157
32.2.	WARNING SYSTEMS.....	157
32.3.	IMPORTANT ISSUES.....	158
32.4.	EVACUATION PREPAREDNESS RESPONSIBILITY.....	159
33.	TECHNICAL ANNEX 22: TRAINING – RESPONSE PLANNING.....	160
33.1.	INTRODUCTION.....	160
33.2.	WHAT TO KNOW? WHAT TO PLAN.....	161
33.3.	EVACUATION POLICY AND PROCEDURE.....	161
33.4.	HOUSE HOLD LEVEL PREPARATION	162
	IF WARNING TIME IS ADEQUATE	163
33.5.	TRAINING AND DRILLS	163
34.	TECHNICAL ANNEX 23: TRAINING –MONITORING AND EVALUATION.....	164
34.1.	DEFINITION OF MONITORING AND EVALUATION.....	164
34.2.	PLACE OF MONITORING AND EVALUATION IN DRC.....	165
34.3.	MONITORING PLAN AND MECHANISM	166
34.4.	EVALUATION TERMINOLOGY	166
34.5.	EVALUATION PLAN.....	167
34.6.	OUTCOME EVALUATION DESIGNS	168
34.7.	COMMUNITY INDICATORS.....	168
34.8.	STEPS IN EVALUATION RESEARCH	168
34.9.	DOCUMENTATION.....	169
35.	APPENDIX A: MAP OF SRI LANKA WITH 32 COASTAL COMMUNITIES.....	170
36.	APPENDIX B: DATA OF RESEARCH MATRIX ALLOCATION.....	171

37.	APPENDIX C: DATA OF HIH OPERATIONAL.....	172
38.	APPENDIX D: DATA OF EFFICIENCY MEASURE FROM LIVE-EXERCISES.....	175
39.	APPENDIX E: DATA FOR CERTAINTY MEASURE OF ICT	180
40.	APPENDIX F: EFFECTIVENESS DATA FOR ALL THE CLIQUES.....	183
40.1.	FULL CAP COMPLETENESS	183
40.2.	ACTIVE ALERT FUNCTION	184
40.3.	ADOPTABILITY.....	184
40.4.	MINIATURIZATION	186
40.5.	TWO-WAY	187
41.	APPENDIX G: OUTCOME OF THE ICT IN THE FIELD.....	188
41.1.	WORLDSPACE ADDRESSABLE SATELLITE RADIO SYSTEM	188
41.2.	DIALOG DISASTER AND EMERGENCY WARNING SYSTEM.....	190
41.3.	SOLANA NETWORKS/INNOVATIVE TECHNOLOGIES VSAT/IPAS.....	192
42.	APPENDIX H – DATA FROM SILENT TESTS.....	195
43.	APPENDIX I – OUTCOME OF ICT ON 12-SEP-2007 TSUNAMI ADVISORY	202
44.	APPENDIX J – DATA COLLECTION SHEETS.....	204
44.1.	DATASHEET 1 – ICT GUARDIAN ALERT LOG	204
44.2.	DATASHEET 3 – COMMUNITY DRILLS EVALUATION FORM.....	209
44.3.	DATASHEET 4 – COUNTING PEOPLE AT STRATEGIC POINTS	214
44.4.	DATASHEET 5 – ICT GUARDIAN DAILY TEST LOG	216
44.5.	DATASHEET 6 – ICT GUARDIAN BREAKDOWN LOG	218
44.6.	DATASHEET 7– EVENT OF INTEREST FORM.....	221
44.7.	DATASHEET 8 – HIH MONITOR DRILL PERFORMANCE EVALUATION.....	222

LIST OF TABLES

Table 1 Discussion of project activities and progress	28
Table 2 LM-HWS Access and Message Management Attributes	35
Table 3 List of acronyms and abbreviations used in this report	58
Table 4 Village categorization relative to the training regime and organizational ranking	63
Table 5 The deployment of ICT combinations in the 32 selected Sarvodaya communities.....	63
Table 6 Synopsis of Sarvodaya development stages	64
Table 7 Cliques and the set of corresponding parameters	70
Table 8 Matrix to determine Message Priority with CAP elements	71
Table 9 Scaling function for Full-CAP Capabilities.....	72
Table 10 Percentage of population by ethnic group (race) literacy in the second languages.....	73
Table 11 Scaling Function for Language Diversity.....	73
Table 12 Scaling Function for Audio and Text Communication Mediums	74
Table 13 Scaling Function for Acknowledgement of Message Receipt.....	75
Table 14 Scaling Function for Bi-directionality	77
Table 15 Parameters associated with calculating TOC	78
Table 17 CAP values for an urgent priority message	103
Table 18 CAP values for a high priority message	104
Table 19 CAP values for a low priority message	104
Table 20 CAP <alert> sub-elements.....	106
Table 21 CAP <info> sub-elements	107
Table 22 CAP <resource> sub-element.....	107
Table 23 CAP <area> sub-element.....	107
Table 24 CAP message <status> values	108
Table 25 CAP message <type> values	109
Table 26 CAP message <scope> values	109
Table 27 CAP message <category> values	110
Table 28 CAP message <event> values.....	110
Table 29 message <areaDesc> values	113
Table 30 CAP status for test categories	116
Table 31 Contact database for confirming events	118
Table 32 Event and site parameters of selected Hazards.....	126
Table 33 Elements at risk	134

Table 34 Parameters for quantifying risk	134
Table 35 Guidelines to do a matrix analysis.....	137
Table 36 Risk categorization by class	137
Table 37 Participatory rural appraisal.....	146
Table 38 Tools of PRA	146
Table 39 Steps in participatory monitoring and evaluation (PME).....	148
Table 40 Disasters according to timing	157
Table 41 Disasters according to predictability	157
Table 42 Disasters according to response time.....	157
Table 43 Evacuation preparedness responsibility.....	159
Table 44 Allocation of ICTs to Communities with training and organizational capacity	171
Table 45 live-exercise data for function: Download, Acknowledgment, & EOI completion	172
Table 46 Live-exercise data for function: Approval Issue and overall efficiency	174
Table 47 Efficiency data for HIH Monitor and ICT Terminal Devices Pre Community.....	175
Table 48 Efficiency data for ICT Guardian and ERP Coordinator in Community	176
Table 49 - Efficiency data summary for all functions in Tables 20 & 21	177
Table 50 Signal strength measured in terms of enumerating bars for each deployment.....	180
Table 51 Mean certainty for each of the ICT deployments	181
Table 52 Description of the ICT capabilities for the Full CAP Completeness set of parameters	183
Table 53 Rating for the ICTs for effectiveness of relaying a Complete Full CAP message	183
Table 54 Description of the ICT capabilities for the Active Alerting set of parameters.....	184
Table 55 Rating of ICTs for effectiveness of Alerting the Last-Mile Communities.....	184
Table 56 Costs associated with each of the ICTs	184
Table 57 Total Cost of Ownership per house hold over three years	185
Table 58 Description of the ICT integration in to daily life of community's perceptions	185
Table 59 Rating of ICTs for effectiveness of Adoptability	186
Table 60 Weight of the ICTs in Kg	186
Table 61 Volume of the ICTs in cubic meters.....	186
Table 62 Lifetime of Power of ICTs in hours.....	187
Table 63 Rating of ICTs for effectiveness of Miniaturization	187
Table 64 Bi-directionality of ICTs in terms of upstream and downstream	187
Table 65 Rating of ICTs for effectiveness of Two-way communication	187
Table 66 Messages received by the RAD and MOP	192
Table 67 Silent test results 06 to 10 August 2007	195

Table 68 Silent test results 15 to 20 October 2007	197
Table 69 Silent test results 26 to 30 December 2007	199
Table 70 Email from Executive Director of Sarvodaya on Tsunami Watch 12-Sep-2007	202
Table 71 Performs of Mobile Phones on the real event of a Tsunami watch on 12-Sep-2007	202

LIST OF FIGURES

Figure 1 Performance summary of the National and Last-Mile components.....	15
Figure 2 Performance summary of the ICTs deployed in the last-mile.....	17
Figure 3 HIH functions and respective average efficiency score	19
Figure 4 Efficiency of Community First-Responders with the presence and absence of ERPs.....	20
Figure 5 Performance summary of ICT-G with respect to the various ICT deployments	21
Figure 6 ICT Guardians with respect to community organization level and ICT deployments.....	23
Figure 7 ERP Coordinator efficiencies with respect to community organization and ICT deployments	24
Figure 8 Efficiency of Communities grouped by District	27
Figure 9 Remote Alarm Device.....	33
Figure 10 Nokia6600 Mobile Phone.....	33
Figure 11 AREA Receivers	34
Figure 12 – VSAT System.....	34
Figure 13 - CDMA Fixed Phone	34
Figure 14 DEWNS Browser SW	37
Figure 15 ANNY Browser SW	37
Figure 16 IPAS Browser SW.....	37
Figure 17 System architecture of an end-to-end hazard detection and warning chain of systems	60
Figure 18 Community-based Alert and Notification communication architecture	60
Figure 19 Microwave Internet link	61
Figure 20 VSAT Internet Link	61
Figure 21 ICT providers, gateways, and technologies linking HIH with the Last-Mile	62
Figure 22 Sequence diagram of the actors and associated functions of LM-HWS	66
Figure 23 Graph for calculating the effectiveness based on signal strength	68
Figure 24 Example of signal strength bars	69

Figure 25 Enumeration function for wake up function	76
Figure 26 Graphs of TCO penalty function	79
Figure 27 Graph of the equation (11) for weights above 20Kg	80
Figure 28 Graph of equation (12) for volume above 0.125m ³	81
Figure 29 Graph of equation (13) from 0 to 16 hours	82
Figure 30 Components of the AREA Terminal device	84
Figure 31 State transition diagram for the AREA systems	84
Figure 32 High level architecture of the DEWNS with network and Terminal Devices	85
Figure 33 Circuit level system architecture of the RAD	86
Figure 34 Expected operational states of the RAD & MOP	88
Figure 35 Rear of BUC ALB and Front/Rear of iDerct Modem	89
Figure 36 Operational States of the IPAS on a Personal Computer (PC).	90
Figure 37 Operational states of 1xRTT CDMA 2000 Unit	92
Figure 38 The LM-HWS depicted as a two-stage relay network	93
Figure 39 Organizational structure of the HIH	96
Figure 40 Simplified procedure for issuing warning messages from the HIH	97
Figure 41 CAP message structure for LM-HWS	105
Figure 42 Sample script based on CAP elements	112
Figure 43 Diagram of risk matrix analysis	136
Figure 44 Diagram of the Disaster Management Cycle	140
Figure 45 Locations of 32 HazInfo project participating communities	170

1. SYNTHESIS

An analysis of the Asian Tsunami of December 2004 showed that thousands of lives could have been saved if Sri Lanka and other affected countries had effective warning systems in place at national and local levels. In December 2005, LIRNEasia, with funding support from the International Development Research Center (IDRC), initiated a research project to evaluate the “last-of-the-mile” communication component of an all-hazards warning system (HazInfo) for Sri Lanka.

For purposes of the HazInfo project, the research focused on the non-government organization (NGO) contribution and was designed around a governance structure whereby the non-profit NGO, Sarvodaya, provided oversight, training, and a hazard information hub for the monitoring of hazard threats and dissemination of alert messages to local communities within the Sarvodaya network of communities utilizing combinations of different Information Communication Technologies (ICTs). The Pilot established Last-Mile networking capability for 32 tsunami-affected communities with 5 ICTs: Addressable Satellite Radios for Emergency Alerting (AREA), Remote Alarm Devices (RAD), Mobile Phones (MOP), Fixed Phones (FXP) and Very Small Aperture Terminals (VSAT).

Results to date suggest that the basic internetworking arrangement at lower technical layers has proven to be reasonably robust and reliable but that a key challenge remains in the upper layers of application software and content provision. This is evident in the apparent difficulties faced when implementing Common Alerting Protocol (CAP) messaging over multiple last-mile systems that include commercial satellite and terrestrial network technologies in modes of voice and text. Lessons learned from Silent-Tests and Live-Exercises point to several key bottlenecks in the system where the integrity of CAP messages is compromised due to problems associated with software interoperability or direct human intervention. The wider implication of this finding is that content standards by themselves are not sufficient to support appropriate and timely emergency response activities. Those working with content standards for hazard information systems must consider closely the interoperability issues at various layers of interconnectivity.

Community-based Last-Mile Hazard Warning System (LM-HWS) Hazard Information Hub (HIH) and Community First-Responders are expected to have Reliability above 90 percent, giving the Communities adequate time to execute their Emergency Response Plans, and not at 77 percent as the system is performing now. This aspect implies that the first responders require rigorous training and certification in emergency communication to avoid ambiguity and misinformation, which is a necessary condition to supplement the deficit of an end-to-end automated alerting system. Further findings indicate that; reliability at the central message relay can be enhanced by introducing a Multilanguage single input multiple output software application (i.e. P2P Multilanguage CAP Broker). The ICTs as stand alone communication systems have 97 percent reliability but have merely 78 percent reliability as warning technologies. Based on the project defined indicators to rate the effectiveness of the ICTs, they were assessed to average 36 percent effective as warning technologies. However, overall performance of the alert and notification last-mile terminal devices is enhanced when a community is equipped with a technology combination that enhances “complimentary redundancy” in reliability and effectiveness; where the combination of the WorldSpace AREA sets and the Dialog/Microimage Java-enabled MOP performed the best with the AREA + FXP following closely.

2. RESEARCH PROBLEM

2.1 Project Objective

“It is easier to be wise with the benefit of hindsight. Yet, lessons learnt -- negative and positive – help in the better design and implementation of future projects. The HazInfo project, which was an action research effort meant to learning while doing, brings out a few important lessons that are summarized in this report¹.”

The overall aim of the project was to set the stage for community-driven initiatives at the last mile of the hazard information dissemination system (HazInfo). The proposal states that it is not an implementation project but a pilot study, based on experimental research design. The function of the pilot study was partly a technology assessment to determine the most cost effective and reliable solutions for a LM-HWS, including an evaluation of their integration into the everyday activities of the community².

An aspect of the project was to expand upon the results of the Last Mile Hazard Warning System by engaging disaster risk reduction techniques in Sarvodaya villages to augment village resiliency and responsiveness to disaster while integrating community-based disaster management through the Sarvodaya Community Disaster Management Center (SCDMC).

2.2 Project Background

The research was based on a “participatory concept paper” (NEWS:SL) developed in the months following the 2004 tsunami. The paper notes that a national early warning system (NEWS) is a “pure public good.” As such, responsibility for its supply would normally fall on the government. However, due to lack of capacity for the foreseeable future, it is unlikely that the last mile of such a system will be provided by the local government or by private firms operating in the marketplace; see Figure 17 in Technical Annex 2 for an illustration of the last-mile system relative to the end-to-end warning system.

The project was, therefore, designed around a governance structure whereby a non-profit, non-governmental organization—Sarvodaya—provided oversight, training, and an information hub for the monitoring of hazard threat conditions and for the initiation of warning messages to local communities in the Sarvodaya network of villages. Designated first responders selected from the local communities were responsible for overseeing emergency preparedness, message dissemination, and emergency response at the local level. Figure 18 in Technical Annex 2 illustrates the Sarvodaya community-based warning system.

An important aim for the study was to address the rural-urban distinction associated with the penetration of communications technology in the Eastern Province and Western Province of Sri Lanka.

¹ This a quote directly extracted from the report presented to the HazInfo Project by the Training Partner: TVE Asia Pacific (<http://www.tveap.org>)

² Gordon Gow, PhD, University of Alberta, Canada, ggow@ualberta.ca .

Disparity in access to communications media in the rural-urban divide is a significant obstacle to achieving effective warning in the last mile of the system in Sri Lanka. Access to resources and training is also split along this rural-urban divide.

2.3 Comments on the Proposed Research

The primary objective was to evaluate the suitability of various ICTs as the basis of a LM-HWS in Sri Lanka. As illustrated in Tables 4 and 5 in Technical Annex 4, an experimental design was proposed to assess the technology. Six factors were to be considered:

- Reliability of the ICTs
- Effectiveness of the ICTs
- Effectiveness of the training regime
- Level of organizational development
- Gender specific response
- Integration of ICTs into everyday life

These factors were assigned a set of corresponding indicators (see Technical Annex 5 to 11) that formed the basis for observations and evaluations of the technology and training. It is important to note that the combination of technology and training involved the specification of distinct but possibility related criteria. In some cases, technology was the critical factor, whereas, in other cases, training was most significant. In most cases, however, some combination of technology and training was responsible for observed results.

Simulated drills took place over 6 month period to gather information with respect to the six stated specific objectives above and following hypotheses:

- Stage 4 & 5 Sarvodaya villages that are more organized, i.e., have a formal structure that enables coordination and direction of activities will respond more effectively to hazard warnings than less organized stage 1, 2 & 3 villages.
- Villages that are provided training in recognizing and responding to hazards along with deployment of ICTs will respond more effectively to hazard warnings than villages that received no training.
- Villages that have ICTs deployed for dissemination of hazard information will respond more effectively to hazard warnings than villages that have to rely on their existing channels of information for warnings.
- ICTs that in addition to their hazard function can also be leveraged in other areas to enrich the lives of the villages will potentially have lower downtime than ICTs that are poorly integrated into the day to day life of the beneficiaries.

Of the initially chosen 10 districts, Colombo, Kalutara, Galle, Matara, Hambantota, Ampara, Kalmunai, and Trincomalee districts successfully completed their Live-Exercises. However, as a result of the North-East conflict, inadequate leadership, lack of resources, and language barriers prevented Jaffna and Batticaloa District from successfully completing training, deploying ICTs, and conducting

Live-Exercise. Of the fully participating communities, all had an equal level of participation and enthusiasm implying that Sarvodaya villages in all stages responded at the same capacity to hazard warnings and disaster resilience capacity building; i.e. all executed tsunami evacuation plans, which is the only emergency response plan the community was trained to execute.

Last-Mile Communities realize the potential of the LM-HWS to help them sleep easy at night. Revoking it without enhancing it based on the research findings and also expanding into the remaining 15,000+ Sarvodaya Communities in Sri Lanka would jeopardize the trust they have in Sarvodaya.

3. RESEARCH FINDING

Indicators of the overall ICT Performance were assessed against the point system based on the composition of a set of scaling functions as described in the Technical Annex 5 – 13 and the expected outcome of the ICTs are discussed in Technical Annex 14. Reader is encouraged to read the Technical Annex prior to continuing this section to better understand the assessment methodology that gives rise to the results discussed in this section. The results are based on a very small sample space and do not show the best comparatives. However, the rating provides the planners with a set of indicators to enhance the reliability and effectiveness of individual components: HIH Message Relay, ICT Networks/Terminal-devices, and Community, of the National and Last-Mile systems; where Figure 1 illustrates a summary of the reliability and effectiveness of the mentioned three components.

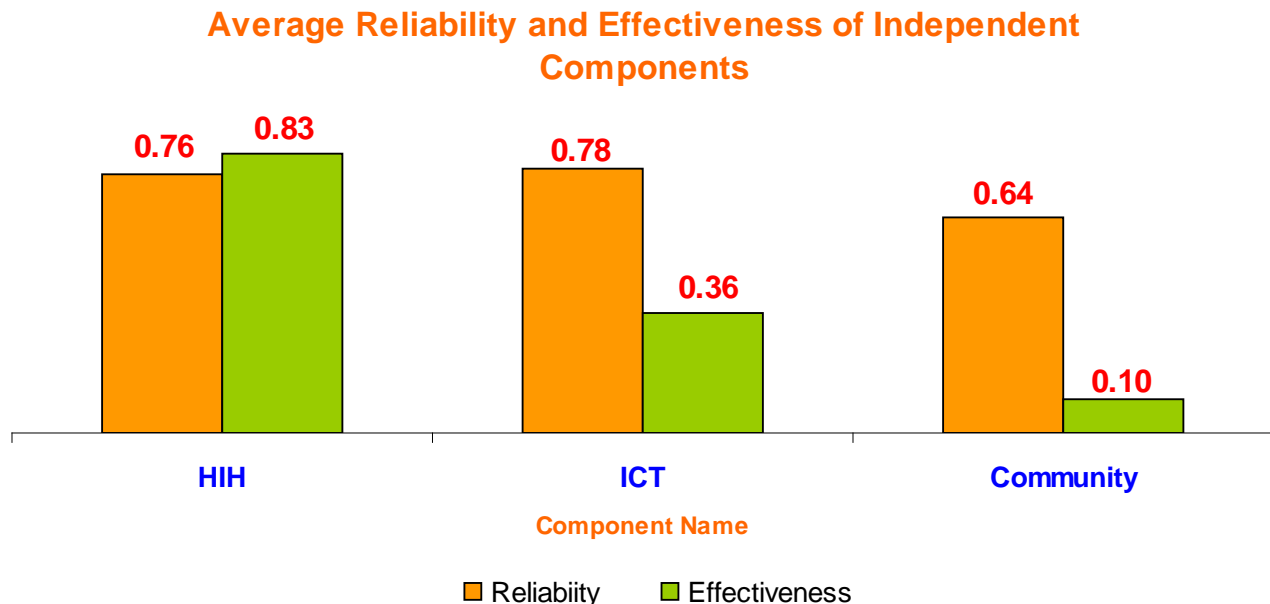

Figure 1 Performance summary of the National and Last-Mile components

The overall performance of the “HIH” in Figure 1, synonymous with the National Warning Center, is acceptable. However, additional training and drills must be conducted for the staff to be well versed

with the procedures and to be able to carry out the tasks within the benchmark time. Section 3.2 discusses gaps in the HIH component. “Pink” components in Figure 17 & 18 contribute the HIH. Effectiveness of the “ICT” component in Figure 1 was well below the expected requirements to be used as an early warning technology. Although the reliability of the ICT component is relatively high it does have several gaps that need to be filled in order to ensure communication certainty and efficiency. Section 3.1 discusses the assessment and analysis of the ICT component in terms of reliability and effectiveness. “Yellow” components in Figure 17 & 18 are what contribute the ICT segment.

“Community” segment, in Figure 1, needs to be focused on the most. The live-exercises revealed that inadequate training and improper notification resulted in unstable behavior. Sections 3.2, 3.3, and 3.4 discuss the performance of the Community component. “Blue” components in Figure 17 & 18 are what contribute to the Community segment.

With the LM-HWS taking the approach of all-hazards all-media alerting and notification, it is vital that unambiguous full CAP messages are issued by the HIH and are received by the Communities. As a result it is recommended that policies are implemented to provide formal training and certification of the HIH-M and ICT-G to be absolutely competent of communicating with accuracy and follow proper procedures. Further exercises must be conducted to realize the true potential of utilizing a Community-based system; especially for the Last-Mile. Since the data reported is from the first trial of its kind it is impossible to adapt methodologies such “Markov Decision Processes” to improve the policies because of the insufficiency of probabilistic data to develop transition probability tables to determine the effectiveness of the policies in practice. However, through conventional trial and error methodologies the pilot project is able to suggest intuitive policies that can strengthen the performance of a National Early Warning System (NEWS).

3.1. Performance of the ICTs as a Warning Technology

This section combines the analysis of the specific objectives related to the technology: reliability of the ICT as a warning technology and effectiveness of the technology as a warning technology. Methodology applied to calculate the reliability of the technology in terms of efficiency and certainty is described in Technical Annex 7. The 11 indicators used to evaluate the effectiveness of the ICTs are discussed in Technical Annex 8.

There is a significant gap between the ICT Reliability as stand alone ICTs and as warning technologies in last-mile communities. The “Reliability of ICT”, in Table 47 in Appendix D, presents the findings as to whether the technology worked on the day of the drill. The average Reliability of ICT in the Last-Mile, recorded in Table 47 (ICT Terminal Devices) in Appendix D, reveals as to how the communities with the particular ICT performed overall during the drills. The number of ICTs distributed in the research matrix (see Tables 44 in Appendix B) is not uniform and also the number of trials conducted for each ICT is not equal.

Despite the envisaged light-speed transmissions in the ICTs, a standard message transmission took approximately 7 seconds to carry a text message from the HIH to the Community, there were delays caused mainly by human errors such as the First-Responder message recipients in the community,

namely the ICT Guardians (ICT-G) not correctly aligning the antennas of the satellite system, accidentally deleting the Java applet on the mobile phone, wrongly configuring the application that restricted receipt of certain levels of hazardous events, ICT-G not being close to the wireless terminal devices to receive the message on time, or simply the ICT Provider terminating the services for not having received a payment for the monthly bill. Tables 67 to 69 in Appendix H show the issues for ICTs failing during Silent-Tests due to the same reasons of ICT-G unavailability, disruption to services, or Terminal Device not always-on and ready to receive alerts. An unusual occasion was the MOP and FXP failing on the day of the exercise as a result of the conflict situation in the North and East of the Island; where the Government Military had instructed all commercial wireless operators, GSM and CDMA, to shut off cells in the respective battle zones. However, the unidirectional AREA satellite based sets functioned in the war-zones when the terrestrial technologies were shut off. As mentioned previously communications in English in the rural communities were difficult for the locals to comprehend. The Active Alert function was not up to par to grab the attention of the ICT-G. Restrictions of the terminal capabilities of carrying a full message caused false information propagation in the communities.

Comparison of Reliability and Effectiveness of ICT as a Warning Technology in a LM-HWS

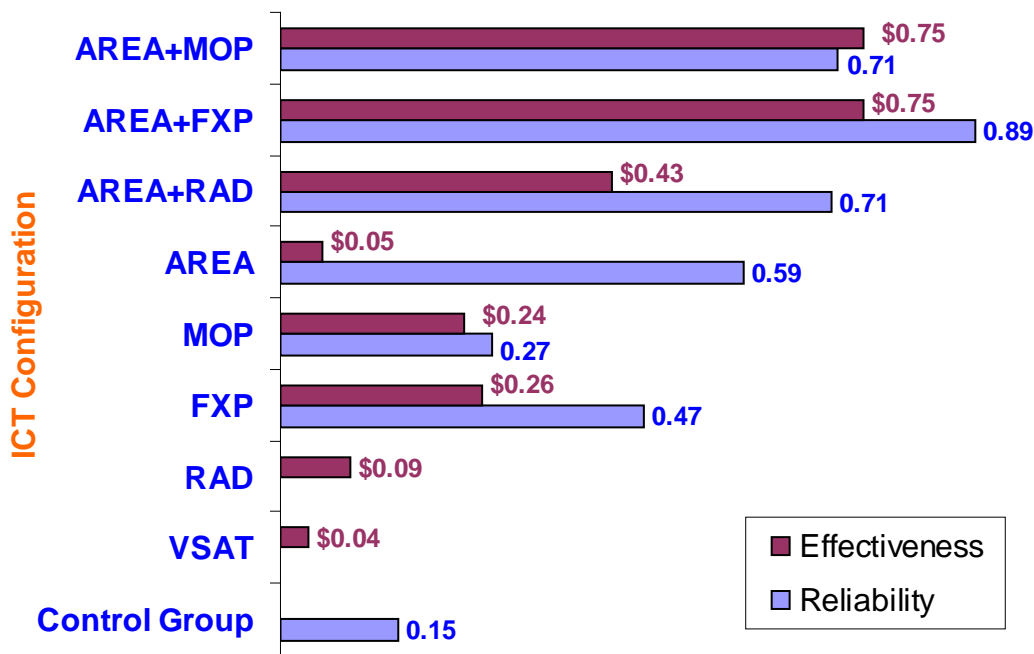

Figure 2 Performance summary of the ICTs deployed in the last-mile

The efficiency outcome of the individual ICTs during live-exercises is given in Table 47, Appendix D. Certainty measures of the individual ICTs recorded on the day of the exercise (live-exercises) at each location are stated in Table 50, Appendix E. The data pertaining to the effectiveness of the ICT Terminal Devices with respect to the 11 indicators is recorded and discussed in Appendix F. Figure 2 summarizes the reliability and effectiveness of the ICT deployments in the selected communities.

Figure 2 shows when individual ICTs: AREA, MOP, FXP, RAD, and VSAT are deployed in the communities the reliability and effectiveness are quite low. However, when they are coupled such as the AREA + MOP and AREA + FXP then the performance is relatively high. The AREA is quite ineffective as a result of the one-way capability but is relatively very reliable as a satellite technology. The MOP is relatively effective since it is capable of displaying alert text messages in Sinhala, Tamil, and English; however, the MOP, as a stand alone, is an unreliable terrestrial technology. When both the AREA and MOP are coupled they complement each other in terms of their respective strengths in reliability and effectiveness, which is termed as “complementary redundancy”.

The reliability scores for the individual RAD was not available because according to ICT deployment in the communities, Table 44 in Appendix B, a stand alone RAD was not deployed in a community. In the case of the VSAT the terminals were not deployed for the community to use the ICT during the live-exercises. The Control Group was not provided with an ICT by the project. However, the communities used available ICTs such a MOPs and FXPs to establish communication with a neighboring community in their district that participated in the live-exercises.

Hypothesis: Villages that have ICTs deployed for dissemination of hazard information will respond more effectively to hazard warnings than villages that have to rely on their existing channels of information for warnings.

Conclusion: All 4 Control Villages that took part in the Live-Exercises had made an alliance with the neighboring Sarvodaya community to receive a telephone call by the Community Chairperson (potential ICT Guardian). The messages were received over their personal GSM mobile or wireless CDMA fixed telephones in the form of a voice call. The Control Villages had prepared in advance to receive the messages. The Reliability of the 4 Control Villages lag because they did not receive the alert directly from the HIH. It is not sure whether the Control Villages would perform this well if it was not a drill or was an unplanned random event. The Reliability of both Communities with ICTs and without ICTs was too weak to make a clean comparison between the 2 sets and support the hypothesis.

3.2. Contribution of the Training Regime

Training Regime in HIH

The training and operational procedures for the HIH is discussed in Technical Annex 15 – “Guidelines for the HIH”. As discussed in Technical Annex 2 and 15, the HIH – Hazard Information Hub (pink block in Figure 18) operational procedures are similar to that of a National Early Warning Center (pink block of Figure 17) The set of HIH functions are -- downloading bulletines from global/local feeds, Acknowledging receipt, generating and EOI (see Datasheet 7 in Appendix I), getting pre-dissemination approvals, and issuing CAP message. With some procedural improvement and training the HIH functions, up to the point of relaying (issuing) the CAP Message, can be made to perform over 0.90 efficiency. However, the bottleneck is in the final step of issuing the message via the ICT interfaces. Some of the delays were caused by login failures as a result of the HIH staff not remembering the multiple passwords or the interface access password had expired and needed

administrative assistance to reset it. As illustrated in Figure 3, the score of 0.69 for the *Relay* function is mainly a result of having to operate a multiple of Single Input Single Output (SISO) message relay software interfaces, which is intuitively a cumbersome task. Data shows that the efficiency drops exponentially when the number of independent applications the HIH has to use increase as a result of repetition of entries. Interfaces that require recording voice messages are a main bottleneck that brings down the efficiencies due to the time consuming recording and editing processes.

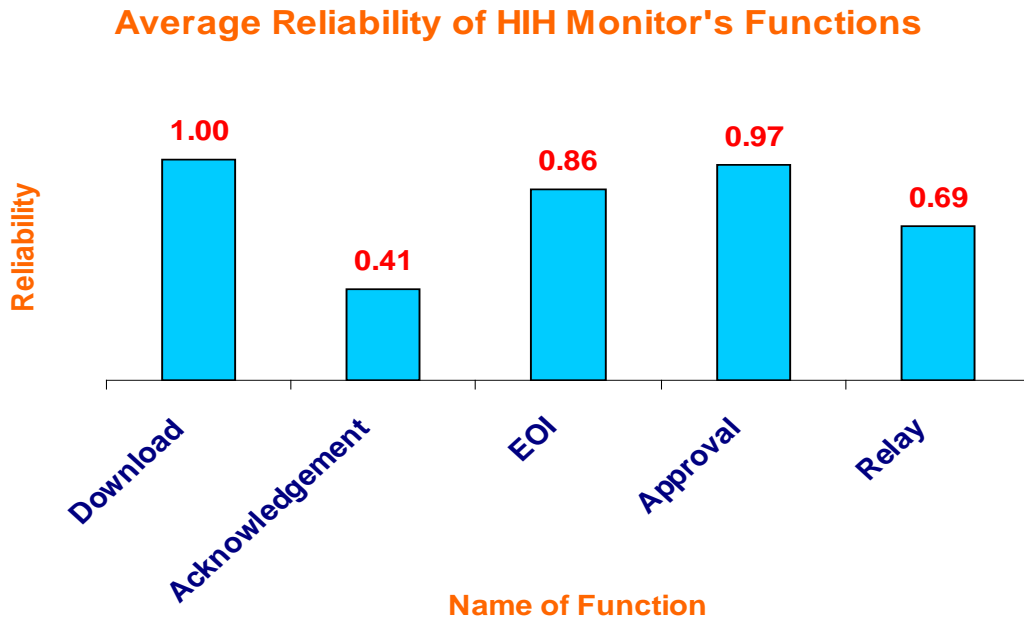

Figure 3 HIH functions and respective average efficiency score

Applying the methodology in Technical Annex 5 for measuring reliability as a function of efficiency Tables 45 & 46 in Appendix C provide the set of data from which the HIH average reliability is calculated. Figure 3 shows the average efficiency for each HIH-M function’s score obtained from all the live-exercises; where the *Acknowledgement* and *Relay* functions are poorest. The low score of 0.40 on acknowledgement is mainly due to over excitement during the exercises and the HIH staff forgetting to follow standard procedures. Therefore, such important tasks must be made mandatory through technology by forcing the staff members to complete the task, else disabling the consequent tasks.

Emergency communication text messaging, in the live-exercises, was mainly in English, except for the Java enabled Multilanguage mobile phone, which carried Sinhala, Tamil, and English. Therefore, the complexity of translating the English CAP messages to Sinhala and Tamil is not reflected in the data too well. However, it is intuitive that without any intelligent real-time natural language translator it would be very difficult for the HIH-M (HIH staff) to achieve expected the 90% Reliability benchmark; especially for all-media all-hazards communications in multiple languages.

EXAMPLE 1: Assuming the duration of a hazard such as a tsunami initiated in the Indian Ocean is 90 minutes, from the time of detection to the time of impact, by applying the methodology (i.e. equation

(3)) for calculating efficiencies, described in Technical Annex 5, an efficiency of 0.78, shown in Figure 1 translates to the HIH taking 21.6 minutes, which is too long and takes away valuable time from the community to activate their evacuation plans. An efficiency of 0.90 would translate to 9.0 minutes, which is what is expected from the HIH. In terms of effectiveness the scoring had dropped below the 0.90 benchmark because the HIH did not populate essential attributes of the EOI form properly. Methodology for evaluating the HIH-M effectiveness is described in Technical Annex 6. There were also inconsistencies in competency levels among different HIH staff scheduled to participate in the respective live-exercises.

Training Regime in Community

There are two sets of Community-First-Responders; namely the ICT-G and the ERP-C. The training content for the ICT-G and ERP-C is taken from Technical Annex 15 and Technical Annex 16 – 23, respectively. The ICT-G simply relay the messages to the ERP-Cs who intern relay the message to the community households. ICT-G have a point-to-point communication protocol; where as the ERP-C must communicate the message to multiple points (i.e. all the households). Therefore, the reliability results, in Table 48, for the ERP-C compared to ICT-G are significantly low because the ERP-C did not broadcast the message but distributed the message from house-to-house either by word-of-mouth (diffusion effect) or with a mobile Pubic Announcing (PA) system. In some cases they used Temple/Church bells and Mosque PA system to broadcast the message. However, these schemes were ineffective because the households did not hear the Temple/Church bell and the ERP-C had to repeat the dissemination process by sending ERP-C out to inform the households by word-of-mouth.

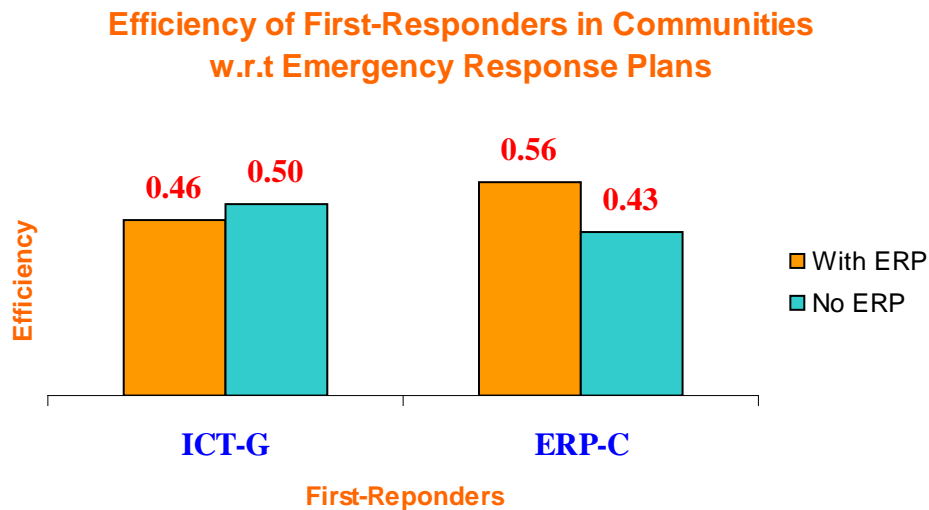

Figure 4 Efficiency of Community First-Responders with the presence and absence of ERPs

Once again, evaluation of the Community segment for reliability as a function of efficiency was calculated using the methodology discusses in Technical Annex 5. The effectiveness of the ICT-G and the ERP Coordinators were measured based on the methodology discussed in Technical Annex 6.

Figure 4 shows that the average efficiency scores of the community First-Responders between communities that received formal ERP training versus communities that did not receive ERP training does not show a significant disparity. The data for this query is obtained by relating Table 44 in Appendix B, of communities that had received formal ERP training versus that didn't, with a combined ICT-G and ERP-C efficiency data in Table 48 in Appendix D. Figure 4 shows that ERP-Cs in communities that received formal ERP training rank higher than those communities that did not receive ERP training. However, the efficiency scores are not close to the expected 0.90 benchmark. All the ICT-Gs received training on operating and up keeping the ICTs but ERP training was only given to those who were belonged to the villages that received ERP training. Regardless the performance expectation levels were very poor. The ICT-G had to be coached during the live-exercises to get them to perform their tasks properly.

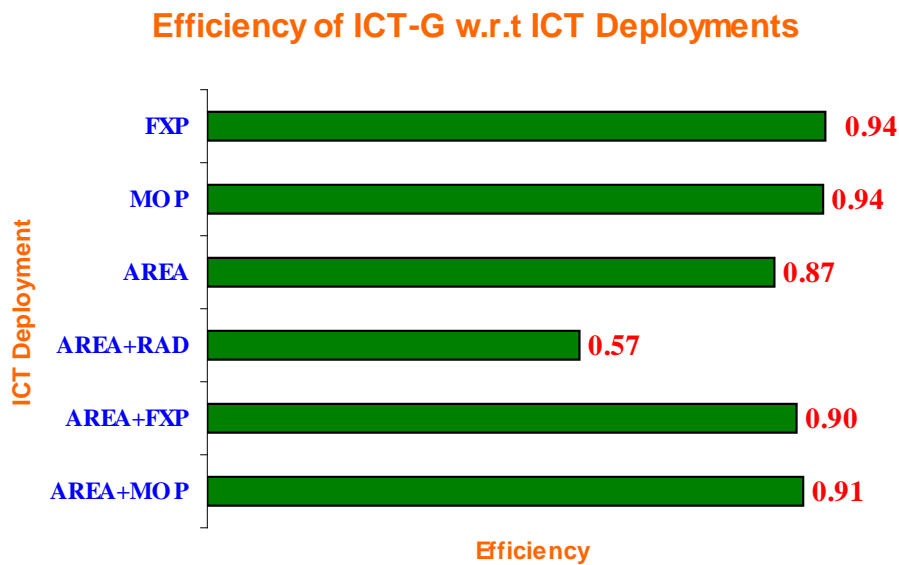

Figure 5 Performance summary of ICT-G with respect to the various ICT deployments

Figure 5 shows a comparison of the various ICT deployments in the communities and the efficiency of the ICT-G in using the ICTs. ICT-G in communities with an AREA+RAD show a significant reduction in the efficiency; where as all other deployments are quite similar and have very little variance in their efficiency scores. RAD was the only device that was a prototype innovation introduced to the project and field tested for the first time. It is apparent from Figure 5 that off-the-shelf readily available ICTs were easily adopted in to the communities; where as the newly introduced RAD was found to be cumbersome to adopt; as a result dragged the score of the AREA+RAD deployment significantly down. Stand alone AREA is slightly below the 0.90 expected benchmark because the AREA is the only device that carried a substantial segment of the CAP text message. Therefore, the ICT-G had to spend a few more extra minutes recording the information in the *Alert Log* (see Datasheet 1 in Appendix J) relative to the other ICT Terminal Devices which did not carry a significant amount of the CAP message but rather a very short message. Results in Figure 5 imply that the ICTs are

unsophisticated and ICT-G can be easily trained to adopt the ICTs as warning device in the communities.

ICT-Gs were forced to decode partial CAP messages received by ICT terminals that could not carry a full CAP message. Shortcomings of the ICT terminals with respect to displaying full CAP messages were a major challenge of Internetworking with CAP for relaying of complete messages. As a result of the partial messages, in many of the live-exercise, mutation of information was witnessed. When the HIIH had issued a “Category 4 Cyclone” alert the communities executed tsunami evacuation plans; i.e. running to a higher grounds when they were actually supposed to seek shelter at lower ground. According to the information in the alert message and the time the ICT-G received the message, the communities had approximately 4-6 hours to prepare for the arrival of the Cyclone. However, the communities thought the hazard was a short fuse type hazard (i.e. tsunami) and ordered immediate evacuation of the community.

The weakness can be blamed on the quality of the training the community had received in developing their ERPs by the Shanthi Sena HazInfo Trainers. It is incorrect to put the blame on the Communities because the CAP structure is constructed to lodge all-hazards all-media unambiguous messages; where the ICT-G is supposed to provide accurate instruction to the ERP Coordinators in order to execute precise ERPs and prevented the community from executing the wrong ERPs. Except for ICT-Gs who were equipped exclusively with an AREA, all other ICT-G had bi-directional means to communicate with the HIIH (upstream communication). Hence, when the ICT-Gs were doubtful of the meaning of the message they had the option of contacting the HIIH or an alternate source to verify the alert communication. In all of the live-exercises none of the ICT-G took the responsibility to either acknowledge receipt of message or attempt to obtain full or further instructions from the HIIH.

Researchers realize that there is a rather significant liability of false information diffusing rapidly in a community if the problem of information mutation at the HIIH, ICT-G, and ERP-C stages is not corrected. Further acknowledge that a comprehensive study of the problem related to information mutation and chaotic behavior due to false information diffusion in a LM-HWS must be studied. Such irregular social phenomena can be studied using techniques such as “patterned chaos forecasting” techniques.

Hypothesis: *Villages that are provided training in recognizing and responding to hazards along with deployment of ICTs will respond more effectively to hazard warnings than villages that received no training.*

Conclusion: *The nature of the Live-Exercises could not determine the effectiveness of the training regime. Overall, it was observed that the response competency level resulting from training was way below expected level. The drills carried out in the communities were predominantly staged by the organizers. Since the organizers were the Shanthi Sena HazInfo Trainers the outcomes of the simulated exercises were identical in each of the communities and shows no disparity between the set of Trained and Untrained Communities. However, the project found that training was imperative for obtain good quality simulation results, reinforcing community emergency planning and raising community awareness about hazards and interest in local risk management.*

3.3. Contribution of Village Organizational Development

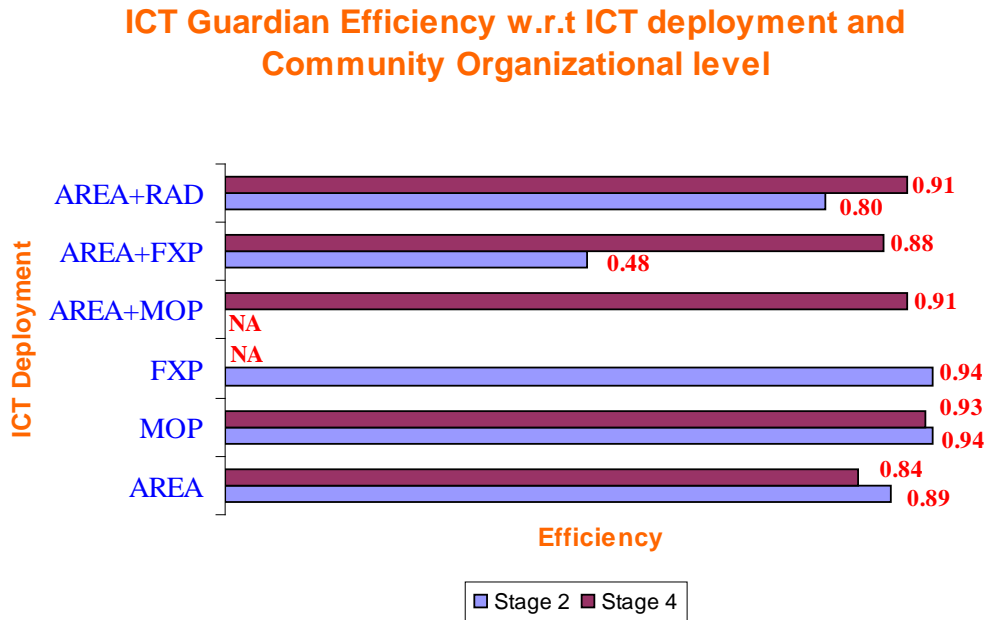

Figure 6 ICT Guardians with respect to community organization level and ICT deployments.

Originally the proposal had partitioned Sarvodaya Stage 1, 2, & 3 villages as less organized and Stages 4 & 5 as more organized communities; description of the Sarvodaya Stages can be found in Table 6 in Technical Annex 4. However, there were no Stage 5 communities in Sarvodaya in the HazInfo project selected coastal districts. Remarkably there were no stage 1 or 3 communities that participated in the project either. The development stage of each village can be obtained from Table 44 in Appendix B. Since the community comprises the ICT-G and ERP-C activities, a comparison of the efficiencies of the two actors are illustrated in Figure 6 and Figure 7.

The label NA – Not Applicable implies that there were no communities with the ICT deployments in communities within the respective organizational category or no data available for those elements. The AREA+MOP were deployed in a Stage 2 Community in Jaffna district where live-exercises couldn't be carried out due to the North-East conflict. Both the Stage 4 communities Inidivina in Hambantota district and Periyakalar in Batticaloa district did not have the capacity to organize live-exercises and participate in the drills. From Figure 6 we may infer that Stage 4 communities are better at adopting a combination of ICTs such as an AREA+RAD or AREA+FXP than Stage 2 communities; the inference would have been stronger if the case was also true for AREA+MOP. The lack in Stage 2 communities adopting the combination of ICTs may be because the AREA and the RAD are a newly introduced ICT opposed to the readily available ICTs such as the MOP or FXP and the less organized communities do not have the organizational capacity to adopt new technologies. However, the efficiency levels are close to benchmark acceptable levels of 0.90. Therefore, it is impossible to draw any conclusions based

on the organizational development level of a community and the ability to adopt ICTs for early warnings.

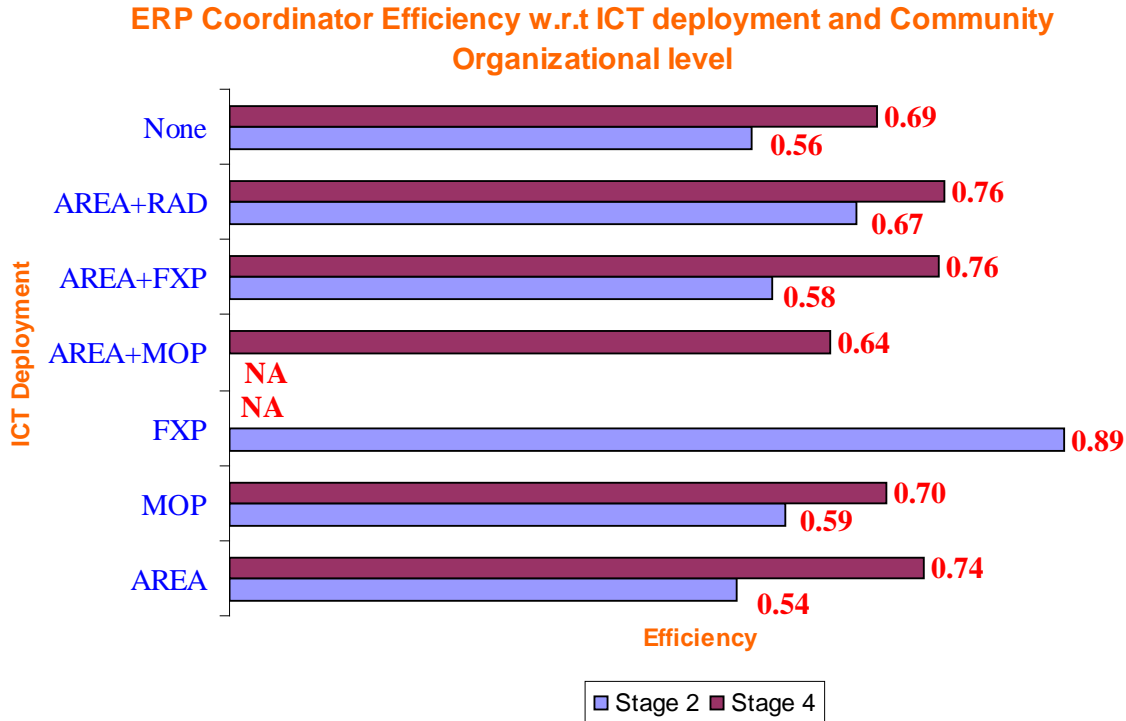

Figure 7 ERP Coordinator efficiencies with respect to community organization and ICT deployments

From Figure 7 in all cases except for the AREA+MOP and FXP the Stage 4 organized communities performed better than the less organized stage 2 communities. On the average the variance between the average efficiencies of the set of stage 4 communities and stage 2 communities is approximately 0.14. Based on the values from Example 1, a 0.14 efficiency margin implies a 12.6 minute difference. However, all the communities with the particular ICT deployments were quite close to the benchmark efficiency of 0.60. Deployments where a none readily available novel ICT was introduced such as the AREA, AREA+FXP, and AREA+RAD, the efficiency gap between the Stage 2 and Stage 4 communities are larger relative to the common MOP. Once again the inference could have been stronger if similar results were shown in the case of the FXP. The NA – Not Applicable label in the case of the FXP and the AREA+MOP are due to unavailability of data. The reasons are similar to the case of the North East conflict and lack of organizational capacity discussed in the Figure 6.

Hypothesis: *Stage 4 & 5 Sarvodaya villages that are more organized, i.e., have a formal structure that enables coordination and direction of activities will respond more effectively to hazard warnings than less organized stage 1, 2 & 3 villages.*

Conclusion: *communities with adequate capacity and organizational structure in their respective Districts proved effective in organizing all project activities as well as adopting new technologies. However, organized communities responded to warnings in the same capacity as the less-organized*

communities.

3.4. Gender Specific Response to Hazard Mitigation Action

Data from Live-exercises reveals that over 72% Adult participants were Female because the simulations were conducted between 9am and 12pm where most Men were occupied with their jobs. For example, the Fishermen would return home around 11am after selling their catch to the merchants and cleaning their nets/boat. Therefore, only the women could participate in the activities. The women showed enthusiasm and willingness to participate in all disaster management activities.

In the rural communities females participated more in community level workshops and training. The outcome is similar to the split indicated in gender participation accounted during the live-exercises. Once again the down fall of male participation levels were due to adult males engaging in “bread-winner” activities.

Participation of female and male in organizational activities in preparing the communities was equally distributed. The volunteers assisting in the organizational activities at the community level were Shanthi Sena youth. Membership in the Shanthi Sena community volunteer force male and female participation is equal.

Given the cultural aspects of females being overlay protected; between males and female Shanthi Sena HazInfo Trainers; i.e. the community ERP trainers, the project found that male trainers were far more versatile and effective as they did not face the same cultural barriers as the females. In most occasions the ERP trainers had to travel outside of their community to far rural places as well as stay overnight, which is not encouraged by parents of female youth trainers. Male trainers were also more vocal and aggressive in getting the training completed.

3.5. Degree of Integration of ICTs in the daily life of villages

Mobile communication component has functionality that needs to be exploited by the communities. The Nokia 6600 Java enabled MOP was used in the project. For instance the “MiDews” applet developed by Microimage would be installed by downloading the applet via GPRS on to the handset and installing to receive DEWN alerts. Hence, the ICT-G was given access to the internet via GPRS. A popular feature was downloading and storing MP3 music files to listen over the MOP. Voice calls was the dominant feature used; where the ICT-G would spend approximately USD15 per month on the average.

CDMA2000 1x_RTT sets are versatile with FAX, SMS, and Internet capabilities. The Internet capabilities have proven to be effective in accessibility, speed, and cost. However, the mobility of the CDMA2000 sets is restricted during Internet access because the communication requires AC power. Only one ICT-G in Batticaloa district used the facility to access the Internet. The project sees that the CDMA2000 sets can be affective in both District Centers and the Community Centers. The Mobile

Phones are useful for coordinators at all levels.

The WorldSpace Satellite Radios have been effective in providing audio content related to Sarvodaya activities directly to the communities. Also the communities have been using the Sarvodaya Talk audio channel to express their opinions on the ongoing projects in their Communities. Ampara and Batticaloa Districts witnessed power outages during the Live-Exercise but received the alerts over the AREA, which was powered by 2 AA Batteries.

The VSAT perhaps is the most highly utilized ICT of the 5 ICTs. It was proven to function on UPS battery power during power failures. The Sarvodaya Community Disaster Management Centre staff used the high bandwidth internet link with an internal hard-wired and wireless network for Skype, email, and Internet services necessary to generate and issue alerts. However, VSAT is too expensive for a community to operate on their own funds.

Overall every ICT has proven to have a unique feature that contributes to the daily functions of the community. Basically if ICT is given and the usage cost is very low then they will use it.

Hypothesis: *ICTs that in addition to their hazard function can also be leveraged in other areas to enrich the lives of the villages will potentially have lower downtime than ICTs that are poorly integrated into the day to day life of the beneficiaries.*

Conclusion: The live-exercises were carried out with prior notification. Therefore, the hypothesis cannot be challenged because the ICT-G had the ICTs powered on. However, the silent-test reveals that the hypothesis is true because ICTs with downtime did not respond to the silent-tests (see Appendix H)

3.6. Local barriers in responding to alerts

Although the following assessment was not required the researchers believe that indicating the results on geographical distribution may be of importance for future planners. The District level summary was a query from Table 48 in Appendix D taken by averaging the overall efficiency of the communities in each District. The message this section attempts to exemplify is the importance of relaying precise hazard information in a timely manner for communities to take proper actions to overcome the barriers described in the following paragraph.

Batticaloa district does not have data as they did not participate in the Live-exercises. Households in Communities of Ampara, and Hambantota districts are sparsely populated (i.e. scattered and far apart). Therefore, the time taken to disseminate the hazard information locally via a Public Announcing (PA) system and completing evacuation were timely. Communities in the towns of Kalmunai district are densely populated with houses enclosed by high boundary walls. Most houses are trapped in between several houses where people have to walk through several back-yards to access the road. Communities in the districts of Kalutara, Matara, and Colombo had the obstacle of crossing the “Galle-road”, one of the busiest roads. Also the railroad travels alongside the Galle-road. In most cases the people trapped between the ocean and the transportation infrastructure did not have a direct path to the inland

evacuation points but had to traverse along the coast line to find a gap to cross the roads and railway tracks to access the evacuation routes. Both Galle and Trincomalee district communities do not face these same barriers. In Galle district, both the railway track and the main road are closer to the coast line with the houses situated inland. Communities in Trincomalee district do not face the barriers faced by the other districts discussed.

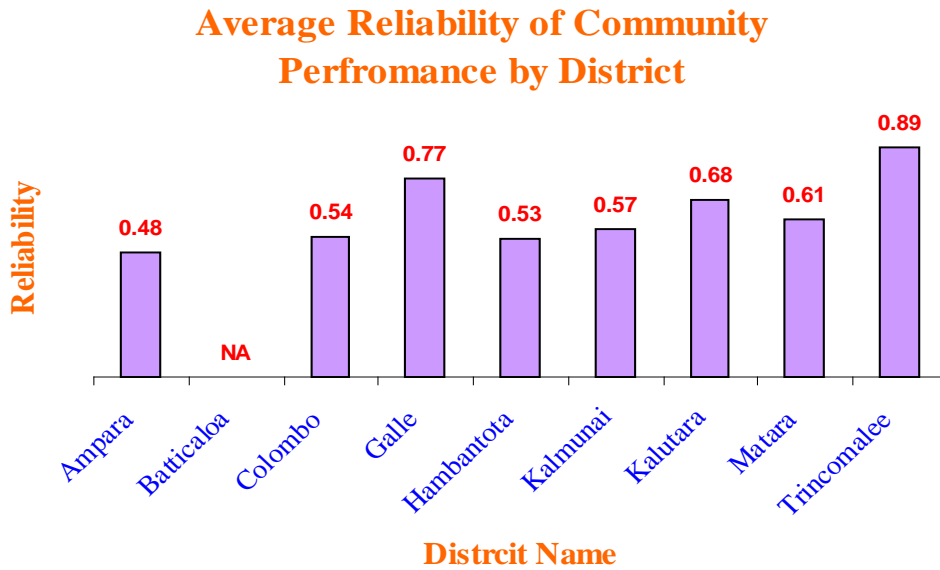

Figure 8 Efficiency of Communities grouped by District

Communities in Kalutara district used Church bells and Mosque PA systems as a local dissemination method. Both religious facilities were located along the coastline. The wind prevented the sound from traveling to the households. People did not hear the local message and delayed in responding. Communities in Matara district area community households span along the coast line. The message was delivered to the households via a PA system mounted on a three-wheeler (tuk-tuk). The households that participated in the live-exercises were stretched along a 10km distance. The three-wheeler with a PA system was inefficient in disseminating the hazard information at a local level. In the real event of a rapid onset hazard such as a Tsunami the tuk-tuk with PA will be inefficient because of the impracticality of the logistics involved with setting up such a system. Colombo district communities have a similar geographical setting and distribution of households as Matara district. Colombo district practiced the same local dissemination method as Matara communities and experienced the same inefficiencies.

4. FULLFILLMENT OF PROJECT OBJECTIVES

Project Start Date: 01-December-2005

Project End Date: 31-November-2007

Project Progress: 92% Completed

Table 1 Discussion of project activities and progress

<i>Activity (% Completed)</i>	<i>Outcome</i>	<i>Start-Date / End-Date</i>	<i>Deliverable (Document type and Authors)</i>
Identification of villages (100%)	Sarvodaya and LIRNEasia select 32 villages from the 226 tsunami affected Sarvodaya villages that reflect geographic, ethnic, socioeconomic diversity and different levels of infrastructural development.	06-Dec-2005 25-Jan-2006	Village and ICT allocation spreadsheet with Community Name and Community Sarvodaya Chairperson's contact details (Spreadsheet, Author: Nandana Jayasinghe, Ravindra Kandage)
Matching technology to village (100%)	See Appendix for Village ICT allocation table The ICT Guardians were recommended by the Community Chair and District Coordinator for that Village	27-Jan-2006 03-Feb-2006	Village ICT allocation spreadsheet with Community name and ICT Guardian's Contact details (Spread Sheet: Jananjaya De Silva)
Supervision of LM-HWS deployment by external vendors (95%)	Dialog Telekom GSM Mobile Communication Research Lab will build, test, and deliver 7 units. Since the RADs were in their prototype stage there were many breakdowns and the equipment had to be sent back to the lab for repair. (100%)	03-Apr-2006 10-Aug-2006	Hardware and Software Inventory (Spreadsheet, Author: Jananjaya De Silva)

<i>Activity (% Completed)</i>	<i>Outcome</i>	<i>Start-Date / End-Date</i>	<i>Deliverable (Document type and Authors)</i>
	<p>There were no problems with the Java enabled Mobile Phones. There were difficulties in remotely installing the Java Alerting Applet. Microimage-Dialog provides a link to access, download, and install the applet through the Internet. However, the poor strength of the GPRS signal made it difficult for the ICT Guardians to install the applet in the remote villages. Therefore, they had to be recalled to Colombo and the applet was installed for them at the HIH. (100%)</p> <p>CDMA Wireless Fixed Phones with 1x_RTT capabilities were provided. However, the SMS, FAX, and Internet capabilities were not enabled for the communities. (100%)</p> <p>All WorldSpace AREA-B systems were received were given to the Community ICT Guardians and District Coordinators after testing them all at the HIH. (100%)</p> <p>The Main VSAT Station was installed by Innovative Technologies and commissioned in October 2006. However, the Community VSAT Station was not installed due to major delays by the vendor. Therefore, Live-exercises could not be carried out in the Community intended to have a VSAT station. (65%)</p>		<p>Administration, Training, and User Manual (Text Document, Authors: S. Rangarajan, Shanmugaraja, Dileeka Dias, P. Warnakulasuriya, Nabil Seddhig)</p> <p>Training workshop for the District Coordinators and Community ICT Guardians (Oral and Visual Presentation, Trainers: S. Rangarajan, S. Shanmugaraja, Gamini Jayasinghe, Mishan Warnakulasuriya, Nuwan Waidyanatha)</p>

Activity (% Completed)	Outcome	Start-Date / End-Date	Deliverable (Document type and Authors)
Creating a hazard information hub (100%)	The Hazard Information Hub (HIH) was setup with office furniture, workstations, conference room, and other peripherals such as photocopy, digital camera. Staff was hired and trained. Building infrastructure such as electricity, water-sanitation, and communication was setup.	19-Dec-2005 25-Apr-2006	DM Institute Infrastructure Inventory (spread sheet, Ravindra Ariyawickrama) Hardware and Software Inventory (spreadsheet, Niluka Wickramasinghe, Jananjaya De Silva) Human Resource Roles and Responsibilities (Text Document, Author: Nandana Jayasinghe) HIH Performance Assessment Report (Text Document, Author: Peter Anderson)
Training of villagers to maintain LM-HWS system	Community Resources and District Resources were trained at Sarvodaya Head Office, at District level, and at Community level. The basic training involved standard operational protocols, ICT maintenance/up-keep, testing, and operational techniques.	03-Apr-2006 11-Sep-2006	Guidelines for HIH and Operational zing LM-HWS (Text Document, Author: Gordon Gow)
Developing protocols for warning & evacuation (100%)		03-Apr-2006 05-May-2006	CAP Profile for Sri Lanka (Text Document: Author: Gordon Gow) Guidelines for HIH (Text Document, Author: Gordon Gow)

Activity (% Completed)	Outcome	Start-Date / End-Date	Deliverable (Document type and Authors)
Education & awareness raising (100%)	TVEAP, the training partner, trained and certified 24 HazInfo Trainers. The HazInfo Trainers conducted awareness programs in the Community and at the District level. The HazInfo Trainers advocated the development of emergency response plans (ERPs) for the Communities.	03-Apr-2006 18-July-2006	Awareness Training Modules 1 – 9 (Text Documents: Authors: Buddhi Weerasinghe, Nalaka Gunawardene) Training List and Assignments (Spread sheet, Author: Ravindra Kandage) Plan and Program Evaluation (Text Document, Author: Ravindra Kandage)
Assessment of LM-HWS technologies through drills (100%)	Silent-Tests were conducted at the HIH, District, and Communities between May-2006 and October-2007 Live-Exercises were conducted in the Communities between Nov-2006 and May-2007	01-June-2006 09-May-2007	Simulation Plans and Evaluation Report (Text Document, Author: Nuwan Waidyanatha, Peter Anderson)
Dissemination of lessons learnt throughout the country (95%)	Please see section 5.0 Project Output and Dissemination Sarvodaya Media Department documented the activities at the HIH and the Communities during the assessment of LM-HWS technologies during the simulated drills	12-Apr-2006 31-May-2007	Last-Mile Hazard Warning System in Sri Lanka: Performance of an Alerting and Notification Message Relay (Text Document and Power Point Presentations, Authors: Nuwan Waidyanatha, Gordon Gow, Peter Anderson) HIH and Community Simulation Video Documentary (DVD, Producer: Nishantha Preethiraj)

<i>Activity (% Completed)</i>	<i>Outcome</i>	<i>Start-Date / End-Date</i>	<i>Deliverable (Document type and Authors)</i>
Project management (100%)	LIRNEasia provided overall coordination and management through the entire project	01-Dec-2006 30-Nov-2007	Project Interim Report 31-May-2006 (Text Document, Author: Nuwan Waidyanatha) Project Interim Report 30-Nov-2006 (Text Document, Author: Nuwan Waidyanatha) Project Interim Report 31-Mar-2007 (Text Document, Author: Nuwan Waidyanatha)
Writing of final report with recommendations (100%)	This document is the final report of the project.	25-May-2007 10-Jun-2007	HazInfo Project Final Technical Report (Text Document, Author: Nuwan Waidyanatha)

5. PROJECT DESIGN AND IMPLEMENTATION

5.1. Concept of Operations

The LM-HWS project consists of two information reception and dissemination stages:

- Reception and authentication of external hazard event and warning information by monitors located at the Sarvodaya Community Disaster Management Centre (SCDMC) Hazard Information Hub (HIH) located in Moratuwa (near Colombo) and dissemination to 28 (4 are controlled villages) targeted Sarvodaya communities specially equipped with LM-HWS ICTs, and
- Reception and authentication of HIH generated messages by ICT Guardians in LM-HWS equipped communities and dissemination of the messages to affected local populations.

When fully implemented, trained and certified monitors at the HIH will monitor, on an around-the-clock basis, a variety of hazard and warning networks and disseminate alerts and other messages of interest to LM-HWS equipped communities. There are 5 steps to initiating an alert message: *recording* an event of interest, *consulting* with a Sarvodaya Executive, *deciding* to send the message, *composing* the Common Alerting Protocol (CAP) message, and *issuing* the message. Alerts issued by the LM-

HWS are not “public” alerts and are intended only to be distributed to “first responders” who have been trained and certified by the SCDMC as ICT Guardians within the LM-HWS Project.

The ICT Guardians are members of the local community and it is they, or their authorized designates, who are responsible for determining if a local, community-wide (village) warning is to be issued. Upon receiving an alert from the HIH, the ICT Guardian must first acknowledge receipt of the message to the HIH and then proceed with notifying local community officials responsible for activating the community emergency plan.

5.2. LM-HWS five wireless ICTs

The LM-HWS project is testing five information and communications technologies:



Figure 9 Remote Alarm Device

Dialog Remote Alarm Devices (RADs)

RADs are stand-alone units that incorporate remotely activated alarms, flashing lights, a broadcast radio receiver to be turned off or on and SMS messages to be displayed, as well as self-test, message acknowledgement and hotline GSM call-back features.



Figure 10 Nokia6600 Mobile Phone

GSM Java enabled SMS mobile phones (Java phones)

Java phones receive text alerts in Sinhala, Tamil and English (Java Phone), activate a Java applet to sound an alarm, and hotline GSM call-back features.



Figure 11 AREA Receivers

Disaster Warning Recovery and Response Addressable Satellite Radio for Emergency Alerts (AREA)

AREA is a WorldSpace satellite radio system that can issue address hazard information directly to those communities at risk. Global Positioning System (GPS) technology incorporated into the radio receiver set, along with the unique code assigned to every receiver, allows for hazard warnings to be issued to sets that are within a vulnerable area or just to radio sets with specific assigned codes.



Figure 12 – VSAT System

Very Small Aperture C-Band Satellite Terminals (VSAT).

VSAT terminals have been installed in two communities and at the HIH. These facilities provide up to a 512 kbps Internet connection and enable testing of the Internet Public Alerting System (IPAS). An IPAS client application installed on a computer enables pop-up messages to appear on a PC screen and an audio alert tone to be played on the computer's sound system.



Figure 13 - CDMA Fixed Phone

CDMA Fixed Wireless Phones (FXPs)

FXP is a CDMA phones with built-in speakerphones to provide voice communication via the public switched telephone network.

As illustrated in Table 2, each ICT relies upon a particular type of network access and message management scheme.

Table 2 LM-HWS Access and Message Management Attributes

<u>Device</u>	<u>Network Access</u>	<u>Message Creation/dissemination Interface</u>	<u>Enabling Partner</u>
RAD	GSM fixed wireless	Password protected Internet website	Dialog Telekom Mobile Communication Laboratory at the University of Moratuwa, MicroImage
Java phones	GSM mobile wireless	Password protected Internet website	Dialog Telekom, MicroImage
Telephone	CDMA fixed wireless	PSTN	Sri Lanka Telecom
VSAT, Internet Public Alerting System	Internet via C-Band fixed satellite wireless	Password protected internet website	Innovative Technologies, Solana Networks
Addressable Satellite Radio	L-Band portable satellite wireless	Password protected Internet website	WorldSpace Global Data Solutions

5.3. ICT Partners and their Contributions

Dialog Telekom: the largest mobile Telco and University of Moratuwa designed, built and supplied 7 Remote Alarm Devices (RAD), supplied 12 mobile phones, developed the Alerting software/applets and provided a 128kbps microwave leased line for the HazInfo project. The “MIDewn” Java Applet for mobile phones, was developed by Microimage (Private) Limited for Dialog Telekom.

Innovative Technologies installed VSAT satellite terminals that have proven to be a strategic tool that can be used for high bandwidth TCP/IP communication for District Centers for VoIP, email, and internet access during office hours and be available for Coordination of Recovery efforts from a District Level. The same link can be the backbone for a Telecenter in the same location. The present Sarvodaya organization communication depends on physical meetings and has proven to be a very expensive process especially for Sarvodaya Staff in North-East parts of the country to travel to the Head Office in Moratuwa (west-coast). A strategically placed set of C-Band VSATs can minimize the travel time and accommodate Video Conferencing, technologies that are far more effective tool than driving on A4 from Kalmunai to Colombo 362km one way.

Based on the post-Tsunami feedback from the affected countries, WorldSpace has designed emergency alert system that incorporates CAP 1.1 formatted message generation, provision for auxiliary audio delivery, automatic switchover at the remote sites, selective addressability, geo-referencing and a host of other features that derive from a digital satellite radio broadcast system. The scheme has been

successfully field-tested and ready to be scaled up quickly. In addition to Sri Lanka, WorldSpace has been testing their Addressable Radios for Emergency Alerts (AREA) products in India, Thailand, and Indonesia. The effectiveness of the AREA system is the Audio and the Data Casting capabilities.

Major technical contributions came to the project via Canadian Experts such as Gordon Gow from University of Alberta and Peter Anderson from Simon Fraser University who have been instrumental in delivering the “Guidelines for HIH” that lays out the CAP Profile for Sri Lanka and the “ICT Assessment and Community Observation Report” that identifies the shortcomings of the system, respectively. Solana Networks, a Canadian Company, pro bono provided and managed IPAS services for the field trials. This includes: full access to the Solana Networks IPAS server, support for creation of public official, ensuring that alerts sent by public officials in Colombo are seamlessly and successfully, upgrading and providing LIRNEasia with new IPAS client software technical support for IPAS as required. Solana Networks intends to upgrade their IPAS system with improving direct access to global sensor networks and adopting CAP for interoperability.

5.4. CAP GUIs and CAP Broker

Common Alerting Protocol (CAP) was integrated into the project because it is an open standard and because of the perceived benefits and advantages of being an open source, XML-based protocol with clearly defined elements and capable of supporting data interchange across multiple dissemination channels. Ideally with CAP, one input at the central information hub can be translated into multiple outputs for downstream alerting. CAP provides a standardized template for submitting observations to the central hub (upstream) and thereby supports situational awareness to improve overall management of a critical incident. Further, a CAP-enabled system will more easily integrate with other national and international information systems (such as regional tsunami and weather alerting services).

An early challenge faced by the project was whether or not the project would need to build a CAP user interface (GUI) from scratch, or whether there was an application available that could be borrowed. The CAP GUI provides a method (a template) for authorized users to enter data into a computer at the HIH and for the transformation of that data into the appropriate CAP XML elements to enable standardized content creation and passage to the various ICTs. The CAP broker is a server application that provides an intermediary point of interconnection between the Information Hub and the relay network to facilitate interconnection of all ICTs and passage of CAP-compliant messages through a single software application.

At this stage of the project, both WorldSpace and MicroImage have developed web browser based CAP GUIs for the LM-HWS project. The WorldSpace CAP GUI (Anny Network Early Warning System or Anny) interfaces with the AREA component and the MicroImage (Disaster Early Warning Network or DEWNS) with the Dialog RAD/Java Phone components. Both the WorldSpace satellite uplink and Dialog Telekom SMS servers are registered as teleports in their respective CAP alerting software. Presently, the AREA and RAD/SMS CAP software operate independently of each other, but in the future, could be integrated and controlled by a single software application (CAP broker). Similarly, the VSAT IP gateway could be added as a teleport and integrated into a common CAP solution along with other ICTs.

The VSAT satellite alerting message software also uses web browser based GUI called Internet Public Alerting System (IPAS). IPAS in its current form is not CAP-compliant but provides a simple and effective means to test sending IP based alerts to PC screens and audio systems.

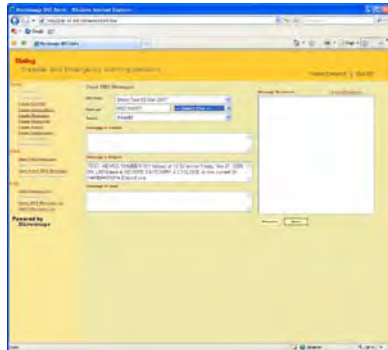

Figure 14 DEWNS Browser SW Figure 15 ANNY Browser SW Figure 16 IPAS Browser SW

6. PROJECT OUTPUT AND DISSEMINATION

Project acquired a supplementary budget to disseminate the results regionally; the outcomes are discussed in a separate report, which was submitted to IDRC along with this report. This section documents events prior to the HazInfo dissemination work began.

6.1. Information Sharing and Disseminations

<u>Event</u>	<u>Description</u>
--------------	--------------------

<u>Event</u>	<u>Description</u>
<i>“Sharing Knowledge on Last-Mile Warning: Community-Based Last-Mile Warning Systems”</i> : Jakarta, Indonesia. March 5, 2008	The workshop took place at the Hotel Borobudur in Jakarta, Indonesia in partnership with the Indonesian Institute for Disaster Preparedness (IIDP). The workshop provided an opportunity to discuss and share the findings of the “Evaluating Last-Mile Hazard Warning Dissemination: A Research Project” (HazInfo) with Indonesian counterparts while at the same time learning about similar initiatives and community-based hazard warning systems.
<i>CPRsouth2 “Empowering rural communities through ICT policy and research”</i> : Chennai, India, December 15-18, 2007	Nuwan Waidyanatha presented his paper on “Last-Mile Hazard Warning System in Sri Lanka: Performance of the ICT First Responder Training Regime” and Natasha Udu-gama presented her paper on “A Last-Mile Hazard Warning System for disaster risk reduction in Sri Lankan villages: Community organization”.
<i>GK3 Session ET4: Emerging Technologies Session on “Making Communities Disaster Resilient”</i> : Kuala Lumpur, Malaysia. December 11, 2007	The session addressed how an alliance of civil society and private sector organizations since the 2004 Indian Ocean tsunami have been striving to develop a robust solution for strengthening community resilience in the face of natural disasters. Panelists shared learning for regional scaling-up of these pilots through discussion, videos and actual equipment demonstrations. The pilots highlighted were the satellite radio from WorldSpace and the GSM-based warning device developed by Dialog Telekom, University of Moratuwa and MicroImage.
<i>Canadian Risk and Hazards Network Annual Symposium, Vancouver 5-8 November 2007.</i>	Peter Anderson and Gordon Gow submitted a joint abstract presented the HazInfo research results at the symposium. Nuwan Waidyanatha was also invited to the event but was unable to attend the symposium.
<i>“Sharing Knowledge on Last-Mile Warning: Community-Based Last-Mile Warning Systems”</i> : New Delhi, November 19, 2007	The All India Disaster Mitigation Institute (AIDMI) and LIRNEasia jointly organized the workshop. This workshop proved to be an ideal venue for the dissemination of findings from the “Evaluating Last-Mile Hazard Information Dissemination” pilot project in India through an intimate gathering of practitioners, private sector, international organizations, local NGOs, and government.
<i>Pacific Northwest Preparedness Society Emergency Preparedness Conference, Vancouver 20-22</i>	Anderson was invited to give a special presentation on the HazInfo project at the conference

<u>Event</u>	<u>Description</u>
November 2007	

<u>Event</u>	<u>Description</u>
<i>19th Meeting of the Wireless World Research Forum: Indian Institute of Technology, Madras, November 2007</i>	Nuwan Waidyanatha presented two papers submitted by LIRNEasia in 2 different working groups and publication in forum proceedings. The first paper titled “Challenges of Optimizing Common Alerting Protocol for SMS based GSM Devices” ⁴ was an output of the “Evaluating Last-Mile Hazard Information Dissemination Project” (or HazInfo Project) research findings, which were presented in the WG1: Human Perspectives and Service Concepts. The second paper titled “Wireless Mesh Networking – as a means of connecting rural communities was based on the design considerations of implementing the mesh network at Mahavilachchiya, Sri Lanka.
<i>“Sharing Knowledge on Last-Mile Warning: Community-based Last-Mile Warning Systems”: Dhaka, Bangladesh. October 25, 2007</i>	The workshop took place in Dhaka on October 25, 2007. LIRNEasia and Bangladesh Network Office for Urban Safety (BNUS) – Bangladesh University of Engineering and Technology jointly organized the Workshop. The Workshop provided an outstanding opportunity for researchers, students, practitioners, and policy makers in Sri Lanka and Bangladesh as well as invited international private sector participants to address and discuss early warning activities from the South Asia Region.
<i>1st Wireless Rural and Emergency Communications Conference: Rome, Italy. October 1-2, 2007</i>	The paper "Community-based Hazard Warnings in Rural Sri Lanka: Performance of Alerting and Notification in a Last-Mile Message Relay," written by Nuwan Waidyanatha (first author), Gordon Gow – University of Alberta, and Peter Anderson from Simon Fraser University. Gordon Gow presented research findings from HazInfo, where a subset of indicators is compared for evaluating system design and performance of the LM-HWS.
<i>“The Role of Telecom Operators and Broadcasters in a National Public Warning System”, BMICH, Sri Lanka, September 7, 2007</i>	Rohan Samarajiva and Natasha Udu-gama of LIRNEasia organized this with the Ministry of Disaster Management and Human Rights (MDMHR), with the support of LIRNEasia, held a meeting on “The Role of Telecom Operators and Broadcasters in a National Public Warning System” with a six of the eight major telecom operators, as well as several disaster management-related government agencies (NBRO, Irrigation Dept., Meteorology Dept., CCP, etc.), UNDP, and a few technical institutes.
<i>2nd International ISCRAM-CHINA Workshop: Harbin Engineering University, August 26-27 2007</i>	Nuwan Waidyanatha presented Evaluating Last-Mile Hazard Information Dissemination: A Research Project, or HazInfo Project, research findings were presented during Session 1: Information Systems along with 20 other papers that were presented in the same session. The HazInfo paper titled “Common Alerting Protocol Message Broker for Last-Mile Hazard Warning System in Sri Lanka: An Essential Component”, edited by Bartel Van de Walle (bartel@uvt.nl),

<u>Event</u>	<u>Description</u>
	Xiaodi Li (lixiaodi2000@hotmail.com), and Shuyu Zhang, was 1 of 115 papers published in the workshop proceedings, pages 59-64, selected from over 200 submissions. The residual session themes were – Business/Organization, Public Organizations/Government, and Mathematical Modeling.
<i>Canadian SSHRC, Saskatoon, May 2007</i>	HazInfo results will also be presented by Gordon Gow as part of the Canadian Communication Association Conference at SSHRC Congress in May 2007 in Saskatoon.
<i>ISCRAM-2007, Delft, Netherlands, May 2007</i>	The paper co-authored by Nuwan Waidyanatha, Gordon Gow and Peter Anderson entitled, “Hazard Warnings in Sri Lanka: Challenges of Internetworking with Common Alerting Protocol” was peer reviewed and accepted for Intelligent Human Computer Systems for Crisis Response and Management, Delft, the Netherlands, May 13-16 2007 and to presented in the session titled – “Flexible Data Structures and Services”. Nuwan Waidyanatha was invited to present the paper and was granted a Euro 1000 Travel Grant to attend the conference. Unfortunately was unable to attend as a result of not receiving a visa to travel to Netherlands on time.
<i>ITU-Arabia, Alexandria, Egypt, April 2007</i>	The International Telecommunication Union (ITU), the League of Arab States (LAS) and a number of other United Nations Agencies in cooperation with the Arab Academy for Science & Technology & Maritime Transport (ITU-D sector member) are organizing a Joint Regional Conference. The event is on “Disaster: Relief and Management: International Cooperation & Role of ICT”, and will take place in Alexandria, Egypt, from 14 to 17 April 2007.
<i>Journal of Emergency Management, March/April 2007</i>	A paper authored by Gordon Gow based on use of CAP for the HazInfo project titled – “Implementing Common Alerting Protocol in Sri Lanka” was accepted and published in the Journal of Emergency Management, Volume 5, Number 1, pages 50-56.
<i>Institute for Construction Training and Development (ICTAD) “Savsiripaya”, Colombo, Friday 30th March, 2007</i>	The Media Conference is following an open public forum, and is being held to enlighten the media and the General Public of the progress made on disaster warning with a focus on community based last-mile warning system. All key stakeholders of the project will attend and will engage with the press in educating them with the lessons learned.
<i>Sarvodaya Head Quarters, Moratuwa, Wednesday 28 &</i>	Forum: “Sharing Knowledge on Disaster Warning, with a focus on Community-based Last-Mile Warning Systems” brought together knowledge from the South Asia Region to Sarvodaya for a forum on

<u>Event</u>	<u>Description</u>
<i>Thursday 29 March, 2007</i>	practical solutions for communicating risk information to rural communities; learn about end-to-end hazard detection and alerting systems that serve grassroots communities in the South Asia Region; obtain feedback on the outputs of “Evaluating Last-Mile Hazard Warning Dissemination: A Research Project” and the Sarvodaya Community Disaster Management Center “Public/Private Partnership Information Communication Framework”.
<i>Improving British Columbia Tsunami Warning, Haida Gwaii Communities, Queen Charlotte Island in North Pacific, January 2007</i>	Experience in applying Sri Lankan ‘last mile’ warning techniques is being shared with coastal villages along the Pacific coast of B.C, Canada, and within the B.C. Tsunami Integrated Preparedness Project (TIP), the main multi-stakeholder tsunami planning group. Prof. Anderson provides regular updates to TIP on progress of the HazInfo project. In January 2007, just before returning to Sri Lanka, he gave presentations and conducted consultations in seven Haida Gwaii communities (Queen Charlotte Islands in northern Pacific) on emergency communications and tsunami warning drawing upon on lessons learned from the HazInfo project.
<i>ITU-ESCAP, Bangkok, Thailand, December 2006</i>	The conference was aimed at addressing interoperability between communication systems, public network utilization for emergencies, required enhancements for public infrastructure, and recent technology changes. Participants also defined the requirements for public warning as well as identifying possible solutions/features of technologies to be used for emergency telecommunications. Prof. Peter Anderson (Simon Fraser University) and Dr. S. Rangarajan (WorldSpace) attended the sessions and presented the HazInfo project and the AREA solutions at the conference.
<i>CBC Radio One, Edmonton, Canada, December 26, 2006</i>	Professor Rohan Samarajiva and Dr. Gordon Gow were interviewed on CBC’s “As it Happens” program.
<i>Bridging the Long ‘Lat-Mile’ in Sri Lanka³: Media Development Journal, UK, 17 November, 2006</i>	Media Development journal has published Mr. Nalaka Gunawardene’s essay titled Bridging the Long ‘Last Mile’ in Sri Lanka in its latest issue (2006/4) which is thematically focused on disasters and communication. This is a non-technical description of what we are trying to do in the HazInfo Project. Nalaka Gunawardene is the Chief Executive Officer of TVE Asia Pacific (Private) limited a lead partner in this project. TVE Asia Pacific conducted the Training-of-Trainers program for the HazInfo project.

³ The paper can be found here --

http://www.wacc.org.uk/wacc/publications/media_development/2006_4/bridging_the_long_last_mile_in_sri_lanka

<u>Event</u>	<u>Description</u>
<i>ITU/OASIS Workshop and Demonstration on Advances in ICT Standards for Public Warning:</i>	Dr. Gordon Gow, Communications Consultant for the HazInfo project presented the CAP initiative in Sri Lanka to the International Telecommunications Union in Geneva. This paper presents the preliminary findings that involve the implementation of the CAP standard to support a local all-hazards warning system in Sri Lanka. In particular, it describes the challenges of implementing a CAP-based information system for managing multi-lingual warnings across a set of five technologies in 32 tsunami-affected villages along the southern and eastern coast of Sri Lanka.
<i>Coastal Community Resilience Initiative: USAID, TAJ Hotel, Colombo, 20 September, 2006</i>	Nuwan Waidyanatha presented the HazInfo Project initiative at the USAID sponsored forum. Under the USAID-funded US Indian Ocean Tsunami Warning System (IOTWS) Program, Coastal Community Resilience (CCR) is a focused initiative that promotes tsunami and other hazard readiness through active collaboration of national and local emergency management agencies, coastal managers, training institutions, and local communities. Building on local knowledge and needs, this effort supports integrated and more standardized hazard awareness and mitigation efforts that improve public safety during emergencies and builds preparedness against recurring disasters.
<i>Institute of Policy Studies Sri Lanka and Oxfam America Disaster Management Forum: TAJ Hotel, Colombo, 17 September, 2006</i>	This workshop was conducted to bring to together stakeholders and share the findings of the review of “Disaster Management: Policy and Practice” undertaken by the Institute of Policy Studies (IPS) of Sri Lanka with financial and logistical support from Oxfam America. The IPS report is intended to assist the government, NGOs and other stakeholders to improve disaster management in Sri Lanka. It is just over a year since the Parliamentary Select Committee on Natural Disasters presented their recommendations and it seems timely to review whether these have been implemented in practice.
<i>Using ICTs for Disaster Management: Heritance Hotel, Ahungalla, 17 June, 2006</i>	The Commonwealth Telecommunications Organization of UK held a 3 day conference in Ahungalle, Sri Lanka, which brought together predominantly Asia Pacific Region and a few International delegates in the field of Disaster Management to present the ongoing projects and initiatives for risk reduction. Rohan Samarajiva was the Keynote speaker and Chair for day one. Nuwan Waidyanatha presented the Last-Mile Hazard Warning Dissemination: A Research Project.
<i>Protocol (CAP) Teleconference for a Last Mile-Hazard Warning System in Sri</i>	The purpose of this discussion was to provide a common point of reference for those parties that will be meeting to discuss the implementation of Common Alerting Protocol within the Sarvodaya/LIRNEasia “Last Mile Hazard Warning System” (LM-

<u>Event</u>	<u>Description</u>
<i>Lanka, 22 March 2006</i>	HWS) project. The scope confined to the implementation of Common Alerting Protocol (CAP) for the project.
<i>Planning workshop on Last-mile Hazard Information Project: Sarvodaya HQ, Moratuwa, 22 January, 2006</i>	LIRNEasia issued invitations and ensured participation by all partners other than Sarvodaya. Sarvodaya, being the provider of the location, took charge of the organizational responsibilities; arrange the actual meeting location, interpretation, etc. LIRNEasia ensured background material was distributed beforehand. The program ensured that all partners have common understanding of the project; achieve common understanding of the ethical issues and our approach; obtain fullest participation by and input from partners on the actual work plan of the project. A task matrix with deadlines and responsibilities were prepared and clearly agreed upon by all partners engaging in the LM-HWS project. Please see Annex 1 – Planning Workshop Program.

6.2. Knowledge Creation

<u>Event</u>	<u>Description</u>
<i>Public Lecture: Sri Lanka Foundation Institute, Colombo, 20 July, 2006</i>	The lecture was free and was open to the public. The lecture with title: Responsive Innovation for Disaster Mitigation addressed all-hazards warning and the use of the Common Alerting Protocol in disaster mitigation. Gordon Gow is an Assistant Professor in the Faculty of Extensions at the University of Alberta, Canada. Co-author of the book: “Mobile and Wireless Communication: An Introduction” and most current book: “Policymaking for Critical Infrastructure”. Moreover, he is the communication systems consultant for “Evaluating a last-mile Hazard Dissemination: A Research Project” in Sri Lanka.
<i>University of Washington Extension Department – USAID/NOAA Tsunami Certificate Program, July 2007</i>	A special international certificate program in tsunami warning is being designed for and offered to emergency managers and policy makers from the Indian Ocean Region by a consortium of international experts and key warning agencies under the coordination of NOAA. Prof. Anderson is a member of the Certificate Program Advisory Board and an invited instructor for the Program’s first course offering in July 2007. He will be leading a special session on ‘last mile’ warning techniques and challenges and will base his presentation largely on the Sri Lankan experience.
<i>International Telecommunications Union (ITU)</i>	Prof. Gordon is currently working with ITU-D (Development Sector) on a set of international guidelines for public alerting that will include an entire section devoted to results from the project in Sri Lanka.

6.3. Training

<u>Event</u>	<u>Description</u>
<i>Sarvodaya HQ, Moratuwa, 17 November, 2006</i>	All ICT Guardians, HazInfo Trainers, District Coordinators, and HIH staff participated in a workshop to discuss the procedures for the Live Simulations. The Workshop was chaired by Prof. Peter Anderson (School of Communication, Simon and Frasier University). Prof. Anderson is the consultant monitoring the simulations and evaluating the HIH. HazInfo Trainers were educated on how to lead a team in observing the community simulations, collecting data, and preparing the simulation evaluation reports for each of the communities. District Coordinators are to oversee the simulation exercises of the communities belonging to their districts. The Divisional Coordinators will assist the District Coordinator and take the responsibility of formally informing the local Government, Police, Medical Officer Health, and Gov Disaster Management Officials.
<i>HazInfo Trainer Refresher Course: Sarvodaya HQ, Moratuwa, February 2007</i>	Shanthi Sena of Sarvodaya organized for the HazInfo Trainers to gather at the Head Quarters to get a refresher course on Training Villages. At the same time the HazInfo Trainers were motivated to by providing an incentive scheme to complete the Simulations. Dr. Buddhi Weerasinghe, Ms. Natasha Udu-gama, and Nandana Jayasinghe made presentations and conducted discussions to enhance awareness.
<i>Training-of-Trainers Workshop at Sarvodaya in Bandaragama, Sri Lanka, 03 April 2006</i>	This was a residential workshop where accommodation was arranged for all participants, and some resource persons, at the venue itself. All meals were provided. The entire training event was conducted in an informal, yet structured manner. Participation in all sessions was mandatory for all participants. "Lecture Presentation": This involved a PowerPoint presentation by resource person/s, sometimes supported by video clips. There was time and opportunity for discussions in all such presentations. "Group work": Most sessions had a specific time for participants to divide themselves into 3 – 4 groups to engage in parallel activities as briefed by the resource team. "Group presentations": This harnessed a short, summarized presentation by the groups through a member of each group selected as rapporteur. "Video presentations": These carefully selected video films integral to the workshop content were shown; preceded and followed by targeted discussions by the resource team. Synopses of videos given towards the end of this note.
<i>Common Alerting</i>	Awareness to village Information and Communication Technology

<u>Event</u>	<u>Description</u>
<i>Protocol Workshop Part II: HQ, Moratuwa, 13 September, 2006</i>	guardians and District Coordinators of each Information and Communication Technologies are evaluating in Last Mile Hazard Warning System (Research Project).
<i>Hazard Information Hub Monitor Training and Certification Course: Sarvodaya Disaster Management Center, Moratuwa, 10 August - 20 September, 2006</i>	This is a course for the training and certification of the hazard Information Hub Monitors. Basis of the course is the Common Alerting Protocol ⁴ (CAP) for Risk Information Communication. The alert messages are issued by an “authorized user” through the Sarvodaya Disaster Risk Management Center Hazard Information Hub (HIH). By the end of the course the Monitors were able to -- 1) Identify an Event of Interest; 2) Confirm EOIs with an Executive; 3) Construct a CAP Message 4) Relay the CAP message. Content emphasized, in the event the government of Sri Lanka issues a public warning, how the Monitor will relay this message directly through its network. If the government does not issue CAP-compliant messages, the Monitor will need to develop a system for translating or reformatting these messages quickly and accurately.
<i>Common Alerting Protocol Workshop I: Sarvodaya HQ, Moratuwa, 21 July, 2006</i>	Ensure that all participants, namely Sarvodaya First Responders (ICT-Guardians), have a good understanding of the Common Alerting Protocol. Provide ICT Administration and User training to all Village and District First-Responders. Introduce the Hazard Information Hub Help Desk functions to the participants. Give the technology partners who designed and developed the ICTs an opportunity to demonstrate their solutions. Handover the ICTs to the Village First-responders. Update the Sarvodaya District Centers of the Last-Mile HazInfo Project current status.
<i>Addressable Satellite Radio Training by WorldSpace: Sarvodaya Disaster Management Center, Moratuwa, 07 June, 2006</i>	Dr. S Rangarajan (Vice President Engineering) and Dr. Wilson Baker (Vice President International Projects) conducted one-day training on standard operational procedures (2 person authentication rule), configuring DAMB-R2 Receivers, and using ANNY Network software to send messages.

⁴ http://www.incident.com/cookbook/index.php/Welcome_to_the_CAP_Cookbook

7. CAPACITY BUILDING

7.1. Local Research and Development

On the ICT development side, the project significantly helped to strengthen and mobilize local research capacity by working with local laboratories such as Lanka Software Foundation (LSF), Dialog-University-of-Moratuwa Communication Research Laboratory and Microimage.

LSF is the advocate of “Sahana”, meaning Relief. Sahana is a Free and Open Source Disaster Management Software developed Disaster Management Practitioners in the World and a core Software Engineering Team of the Lanka Software Foundation based at the University of Colombo. The Sahana Team developed the Messaging Module for Sahana and included the CAP component in there. A Demo⁵ of the current version is deployed in the demo release of Sahana.

7.2. Hazard Information Hub Monitor Course

In August 2006, HIH staff were given training for certification as Hazard Information Hub Monitors and “authorized users” (HIH Monitors). The core element of the course used the Common Alerting Protocol for supporting message creation and communication. By the end of the course, the HIH Monitors were able to: 1) *identify* an Event of Interest (EOI), 2) *confirm* the EOIs with a member of the Sarvodaya Executive, 3) *construct* a CAP Message, and 4) *relay* the CAP message to designated communities using a particular combination of LM-HWS ICT devices.

The training also emphasized, in the event the government of Sri Lanka issues a public warning, how the HIH Monitor should relay this message directly through the LM-HWS network. If the government does not issue CAP-compliant messages, the Monitor will translate or reformat these messages quickly and accurately into a LM-HWS CAP-compliant message.

Technical Annex 15 contains the training material and the procedural guidelines for the HIH.

7.3. Village Training of Community First-Responders

Training at the village level consists of two training components: 1) general disaster preparedness training for village trainers and 2) specific training for ICT Guardians.

Training of Trainers

The Training of Trainers (TOT) component forms the education component envisaged in LM-HWS as the underpinning training to instill an effective warning response. Those trained (known as HIH

⁵ To access Sahana Demo -- <http://demo.sahana.lk/>

Trainers), in turn, are to train ICT Guardians and others at the community level.

The newly trained trainers are expected to be able to:

- Instill awareness of hazards, vulnerability, and risk.
- Conduct community based hazard mapping, resource mapping, risk assessment and identification of vulnerable households and groups of people in the community.
- Create awareness of the early warning mechanism in place and the response activities that need to be undertaken.
- Enable the identification of appropriate dissemination mechanisms to vulnerable households.
- Enable formulation of a response plan, which includes an evacuation plan with clear actions, roles and responsibilities and identify resources needed.
- Instill the competency to conduct an evacuation drill which is comprehensive.
- Provide the ability to measure the effectiveness of response plans carried out as simulations.

TOT took place in Bandaragama in April 2006 and February 2007 and was conducted by the training partner – TVE Asia Pacific. Currently, 16 of the 32 participating communities received training as part of a controlled group in the pilot study. Technical Annex 16 – 23 contains the course material used in the 8 training sessions.

ICT Guardian Training

In July, 2006, a workshop was held at Sarvodaya in Moratuwa to train the Sarvodaya Village and District first responders with the objectives of:

- Ensuring that all participants, namely Sarvodaya first responders, have a good understanding of the Common Alerting Protocol.
- Providing ICT administration and user training to all village and district first responders.
- Introducing the Hazard Information Hub Help Desk functions to the participants.
- Giving the technology partners who designed and developed the ICTs an opportunity to demonstrate their solutions.
- Handing over the ICTs to the Village first responders. Those responsible for their operation were designated as “ICT Guardians”.

This training was supplemented through district level workshops conducted prior to community simulation exercises from November 2006 through March 2007.

Another change in the project was the decision to Train the Untrained Communities. This would happen shortly after the completion of simulations. This way it wouldn't affect the research results and all participating villages will be trained to the same level and all villages will have improved their alerting and response capacity.

8. PROJECT MANAGEMENT

The Last Mile Hazard Information Dissemination Project was a multi-partner, civil society initiative to complement other action being taken at national and regional levels. However, both private sector and public sector participation was under-represented. Only WorldSpace and TVEAP took a large interest in the project; all others gave a lower priority to the project. Hence, there were delays in activities, additional expenditures of time and resources to achieve goals, and overall a lower level of outcome relative to expected results. The media partners (except TVEAP) had failed to deliver. The VSAT partner was slow in delivering; the project had no choice but to use the exclusive vendor available in the market, and to bow to the vendors' time line. Although, this turnkey component was slower in being inaugurated, the quality of service of the VSAT provider has been excellent.

The Sri Lanka "North-East" Conflict between the Liberation Tamil Tigers for Elam and the Sri Lanka Government has forced the project from running Live-Exercises in Jaffna District. Similarly, the Hambantota District was affected by floods and damn breaks, giving people enough to worry about than concentrate of Live-Exercises. The drills were completed later in May 2007. At least 1 Silent-Test with the ICT-Guardian was conducted by the HIH-Monitor initiating the Silent-Test. Table 6 below defines the allocation of ICTs and the participating communities with the specific ICT.

Project Management in Sri Lanka requires plenty of buffer time because of anticipated delays. The Sri Lankan society is not used to working according to plans, nor do they adhere to concept of deadlines. The reason being Sri Lankan society is used to giving excuses for not being able achieve the targets opposed to concentrating on the tasks and striving to provide solutions. As a result the 2-year project was re-planned with multiple parallel tasks over a 1-year period. The outcome of this tight-plan was that the project completed all activities in 18 months.

The Project Plan was constructed anticipating all tasks would be delivered on time. Therefore, the Training began immediately following the planning meeting anticipating that the ICTs would be delivered and commissioned on time. However, this assumption backfired causing a huge gap between the training period and the delivery of equipment. Therefore, the communities had to be given a refresher cause after all the ICTs were delivered. The delay in ICT delivery caused the simulations to be delayed as well. The communities had been trained at the beginning of the project and they had developed their ERPs at that time. Because the simulations happened only 8 months after, most communities had forgotten their emergency response plans. In the future, it is important to wait for the delivery of equipment and services before providing the training at the last moment.

Originally the Sarvodaya District Coordinators and Division Coordinators were trained at workshops to take the training in to the communities to ready them for the simulation activities. However, this strategy failed and multiple field visits had to be made to motivate and train the communities to engage in the simulations. Also the Sarvodaya District Coordinators, Divisional Coordinators, and Volunteers had to be given monetary incentives in order to motivate them to conduct project activities. The incentives were based on the delivery of community simulation progress report, which consisted of assessments provided to them by the project.

The original budget of the project had to be restructured to fit the actual requirements. Otherwise, it would have been impossible to take the project forward. The major components were reallocating funds for much needed Workshops for capacity building and reducing the number of VSAT stations. Dialog Telekom, GSM technology Partner, donated time and equipment. Therefore, the project was able to reallocate money set aside for this equipment towards Workshops. The number of VSATs had to be reduced because the money allocated in the original budget was for Ku-band VSATs, which have proven to be very unreliable in the tropical climate of Sri Lanka. Therefore, slightly more expensive C-band VSATs had to be used in the project. Also Infrastructure, Office-equipment and IT Hardware that were allocated for all 5 VSAT Stations were reallocated towards Workshops because the project was able to use IT Hardware and Infrastructure that was already available for Sarvodaya through other projects.

Simulations were first scheduled to be conducted over a 6 week period starting in November and Finishing in December. This strategy failed because the Sarvodaya District Coordinators could not agree to the dates due to commitments to other project activities. North-East (NE) District Coordinators were tied up with the Internally Displaced People (IDP) as a result of the NE conflict. A couple of the Communities and District Centers had Organizational dysfunctional issues. The HIH did not have adequate capacity to assist in deficiencies in scheduling and executing simulations in the communities.

9. IMPACT

Last-Mile Communities realize the potential of the LM-HWS to help them sleep easy at night. Revoking it without enhancing it based on the research findings and also expanding into the remaining 15000+ Communities in Sri Lanka would jeopardize the trust they have in Sarvodaya. The communities strongly requested that the DM programs be continued and not let them subside as most things do. All Sarvodaya trained villages had started an “Emergency Disaster Management Committee”. In most cases the committee comprises members of the Sarvodaya Shanthi Sena Volunteers. Table top exercises revealed that all communities needed guidance and assistance to strengthen the resilience in their neighborhoods.

Sri Lankan Government is only now firming the mechanisms of early warning and dissemination and the experiences of the Last Mile HazInfo Project may be invaluable in this process in the coming years.

The research aims of the project were not always apparent to those involved at the grassroots level delivery of project services or to the beneficiaries themselves. This led to unrealistic expectations in some cases, for example when certain communities wanted the VSAT rather than an ordinary fixed phone or mobile phone. A common psychology among communities is to regard a more complex (and expensive) technology tool as somehow more important than a ubiquitous one.

The disadvantages encountered in the project may convert itself into strengths in the future as lessons learnt at community level would certainly enrich the next phase of the project that is being envisaged.

A critical drawback of the project was that most of these village-trainers and HIH Monitors could not be retained with the project due to various personal factors. As such, some left when they gained paid employment. The second batch of volunteers, although given some orientation and guidance, did not receive the same intensive training that was directed to the first batch. This caused a loss of some momentum and motivation, but it was unavoidable. Such a level of turn over in personnel may cause an imbalance in the integrity of the system. As a result the LM-HWS may not be able to provide the expected level of services the communities require.

10. OVERALL ASSESSMENT

In general, the project revealed that with the recommended enhancements described in this report, the five tested ICTs can be incorporated into the communities and form a critical infrastructure. However, most importantly, from a technical perspective, all ICTs used in the HazInfo Pilot must be upgraded to receive Complete Full-CAP Messages before they can be used in the Last-Mile Communities of Sri Lanka. Further, before the CAP Profile can be implemented in such a last mile system, the system must first develop the Human Capacity: HIH-Monitors, ICT Guardians, and ERP Coordinators, in order to supplement the deficiencies of an end-to-end fully-automatic early warning system. Thereafter, simulated drills must be conducted regularly to develop the Cognitive Framework to ensure all ERPs can be smoothly carried out without confusion.

From the simulations is apparent that given proper training of HIH staff, timely access to external hazard event information and the appropriate ICT, the time taken to process and disseminate an alert from the Hazard Information Hub (HIH) can be absolutely minimal. This can give the communities, the majority of the time (75% or more between the time of receiving the event information at the HIH and the estimated time of hazard impact) to execute their ERPs. However, the project sees that this timing advantages can only be effectively achieved by a “CAP Broker” that will integrate and improve interoperability among the ICT CAP systems and provide the single input - multiple output facility that HIH Monitors need to speed up the capturing of event information, get authorization and disseminate CAP messages efficiently and accurately. The CAP Broker can be developed by redesigning the existing tested WorldSpace ANNY, Dialog-University-of-Moratuwa-Microimage DEWNS, and Solana Network’s IPAS software systems. In addition the CAP Broker would require a Geological Information Systems (GIS) based Graphic User Interface (GUI).

A disadvantage was that the absence of a culture of last mile dissemination of early warnings in Sri Lanka – in this sense, HazInfo project was breaking new ground. The practice until now has been for information to be ‘broadcast’ to the whole country in a central manner. Introducing Addressability and the community-based approach was a challenge, and gathering momentum in the field was at times slow due to this reason.

11. RECOMMENDATIONS

11.1. Message formatting - the HIIH and the Government

In the event the government of Sri Lanka issues a public warning, the HIIH will relay this message directly through its network. Local first responders will act on the message as they see fit, based on local response plans and any instructions provided by the government in the initial message or in subsequent public communications (e.g., official messages broadcast by the media).

If the government does not issue CAP-compliant messages, the HIIH will need to develop a system for translating or reformatting these messages quickly and accurately. If government messages are issued in another standard format it might be possible to automate this process. However, in no case should personnel at the HIIH modify or otherwise revise the contents government message, except to ensure that it is capable of being relayed over the HazInfo network.

It is recommended that an element in the CAP data definition document (the Profile Document) be assigned to indicate that a warning message has been issued directly from the government of Sri Lanka.

In fact, it is advisable that the selected CAP data element be able to contain the entire government message as a single payload that can be copied and pasted into a CAP message, rather than asking HIIH personnel to interpret or to transcribe the message and risk introducing errors in the transcription process.

11.2. Further Test ICT Assessment Tools and Methodologies

In addition to the core activities, the Partnership for Public Warning (PPW) has identified a list of recommended best practices (RBPs) to consider when devising a warning strategy. These RBPs can be applied to each of the three core activities to produce a matrix with specific recommendations for the HazInfo initiative. The first column on the left lists 39 RBPs based on those identified by the PPW. The second column lists operational issues related to the RBPs. The third column lists approximately 120 specific recommendations for the design and implementation of a HazInfo system. These are categorized into each of the three core activities: planning, education and training, testing and evaluation.

11.3. Table Top Exercise for Selected Members in Community

It is recommended that all villages participating in the project benefit equally from training opportunities offered by the HazInfo Project. After consultation with HazInfo Project Districts and Villages at the pre-simulation workshop, consensus was reached that it would not be appropriate to fully exercise villages that are not trained, to avoid creating confusion among residents about the intended purpose of the simulation. Further, there are public safety considerations that must be

considered in advance whenever public participation is sought in such exercises. There was a change of strategy to engage untrained villages in the simulation exercise. Although the simulation exercise proceeded as originally planned and untrained villages did not receive additional training up to the time of receipt of the alert message from the HIH, at each untrained village HIH trainers and District coordinators conducted a “table top exercise”; with relevant officials at the village location where the Last Mile alerts would arrive. The table top exercise was in the form of an around-the-table discussion about what steps the village would take in the event the alert message was real, followed by HIH trainers taking participants through an introduction to disaster planning; to be followed by a full training workshop at a future date. In this way, shortly after the completion of simulations all participating villages would be trained to the same level and all villages have improved their alerting and response capacity.

This procedure provides a model for future expansion of the project. A slightly modified version of this table top process can also be applied in trained villages where circumstances prevent them from conducting full community simulations. All villages, trained and untrained, will also be able to complete the HIH-to-village Last Mile technical simulations.

11.4. Training and Certification of HIH Monitors

It is recommended that an authorization procedure be developed for HIH staff members to qualify them as “Authorized Users” with the authority (and related responsibilities) to compose and issue warning messages over the HazInfo system.

All new HazInfo personnel should be required to attend a training session provided by the HIH/Sarvodaya. In addition all authorized users should be required to attend regular refresher training to maintain their status. Regular training sessions could be scheduled prior to the cyclone season in November. In addition, authorized users should be required to complete monthly practice sessions composing and initiating messages using the system. To promote compliance, the HIH computers could be designed to log these monthly sessions.

11.5. Training of ICT Guardians

It is recommended that HIH develop a series of basic HazInfo set up, operational and maintenance checklists and guidelines, and that they be distributed in all appropriate languages. It is further recommended that HIH examine how HazInfo components could be used to deliver regular updates to ICT Guardians – especially the AREA audio service and that refresher and advanced user courses be considered as well as Training Of Trainer program for ICT Guardians be offered to encourage inter-community self-help.

11.6. Community-based Emergency Communications Planning and Training

It is recommended that a new module be added in the next phase of the project that would include

community-based emergency communications planning incorporating communications needs assessments based upon community emergency response plan concepts of operation, an inventory of communication means, communications capacity and vulnerability assessment and gap analysis, along with operational training.

11.7. Contribution to CAP Research through Working Groups

It is recommended that a special R&D working group be established and retained to pursue further development of CAP and its integration with the project's and other emerging ICTs that can support hazard warning and situation awareness.

A major component of the project is the use of the Common Alerting Protocol to enable data interchange between the HIIH and a range of technologies. However, there are many issues remaining to be resolved in order to fully operationalize CAP. These include interoperability, language and message display capacity and are further discussed below. Because of the global characteristics of these implementation issues, the CAP component of the study could make an important contribution regionally and perhaps worldwide for the deployment of this relatively new standard for emergency alerting. As such, considerable attention should be paid to the CAP implementation methodology and to documentation of the implementation process.

Some decisions are also concerned with localizing CAP for the specific Sri Lankan context (e.g., language, geographical regions, hazards, etc.). Other decisions are concerned with information management requirements that stem from the use of CAP and the long term path dependencies associated with future expansion of CAP within Sri Lanka and in the Indian Ocean region.

The decision-making process is also an important component of the pilot study, as it will provide lessons learned for implementing CAP in other organizations in Sri Lanka and in other countries. For this reason, it is important to preserve a record of events during the implementation and testing stages and to encourage broader participation through a working group.

11.8. Enhance and Test ICTs with Complete and Full CAP Features

It is recommended that all HazInfo ICTs be capable of full CAP featured and multilingual message display. In this project, a Complete Full-CAP Message is defined as one that complies with the CAP Profile for Sri Lanka, contains all three languages: Sinhala, Tamil, and English, and also is disseminated in modes of Audio (i.e. Voice) and Text. The final rating is the multiplication of the values obtained from Tables 2, 3, & 4.

Presently, the HazInfo project does not employ a multi-language device that is capable of displaying the entire CAP message. The WorldSpace optional Alert Box is the only device that can display the entire CAP message. However, it is currently configured for English language character only. Therefore, ICT-Guardians have had to learn to interpret the English partial CAP Messages. Considering the low level of English language usage especially in rural Sri Lanka, ideally, the devices

should enable the ICT Guardians to select the message language of choice (i.e. Sinhala, Tamil, or English).⁶

Of the five ICTs used in the project, only three make use of the CAP message format (AREA, RAD and MOP). However, each is only capable of displaying a limited number of the CAP elements, limiting the amount of alert message content. Consequently, during simulations ICT-Guardians restricted their CAP message content creation to recording only a few elements such as the <msgType> and <Event> and did not include <urgency>, <severity>, and <certainty> to enable ICT-Guardians to gauge the Priority. One reason particular reason for doing so was that only the WorldSpace AREA units could display these qualifier elements. Although, the RAD and MOP devices use the <Description> element that could also carry this information, they are restricted to an overall message content limit of 130 characters.

11.9. Free and Open Source Software CAP Broker

It is recommended that a free and open source software program (CAP Broker) be developed to integrate the project's individual CAP message generators and processors to serve as a single non-repetitive data input and import/export function.

An early challenge faced by the project was whether or not the project would need to build a CAP user interface (GUI) from scratch, or whether there was an application available that could be borrowed. The CAP GUI provides a method (a template) for authorized users to enter data into a computer at the HIH and for the transformation of that data into the appropriate CAP XML elements to enable standardized content creation and passage to the various ICTs. The CAP broker is a server application that provides an intermediary point of interconnection between the Information Hub and the relay network to facilitate interconnection of all ICTs and passage of CAP-compliant messages through a single software application.

At this stage of the project, both WorldSpace and MicroImage have developed web browser based CAP GUIs for the HazInfo project. The WorldSpace CAP GUI (Anny Network Early Warning System or Anny) interfaces with the AREA component and the MicroImage (Disaster Early Warning Network or DEWNS) with the Dialog RAD/Java Phone components. Both the WorldSpace satellite uplink and Dialog Telekom SMS servers are registered as teleports in their respective CAP alerting software. Presently, the AREA and RAD/SMS CAP software operate independently of each other, but in the future, could be integrated and controlled by a single software application (CAP broker). Similarly, the VSAT IP gateway could be added as a teleport and integrated into a common CAP solution along with other ICTs.

The VSAT satellite alerting message software also uses web browser based GUI called Internet Public

⁶ A report by Anderson, Peter [1] describes in detail the shortcomings of the ICTs and recommends enhancements to make the ICTs usable in the last-mile of Sri Lanka. The report further proposes an integrated software system that can automate some of the HIH processes to make it easy on the HIH Monitors to minimize the dissemination times.

Alerting System (IPAS). IPAS in its current form is not CAP-compliant but provides a simple and effective means to test sending IP based alerts to PC screens and audio systems.

Global hazard monitoring organizations such as United States Geological Survey (USGS) and Pacific Tsunami Warning Center (PTWC) also issue CAP format messages. However, throughout the project, it was discovered that not all organizations, including USGS and PTWC, use the same OASIS CAP version making it difficult to automatically import their CAP Messages into the HazInfo CAP readers and thus requiring manual transfer of data for relaying timely Events of Interest.

For the HazInfo CAP Broker, the current inputs will come in the form of text and voice. The message editor should be capable of transforming the audio and/or text to fit the defined CAP format. In most cases the message will be entered by the user. In a few cases the interface to external sources will be direct without any user interference.

A natural language translator will take a CAP input in any language and translate the message to select other languages. The user should be able to switch between languages as and when needed. Hence, the GUI must also change to fit the localization requirement; i.e. switch to the selected language. The user can then enter the CAP message in their language of choice.

Thereafter, the translator in the Message Relay component will convert the message to the specified languages and file formats.

After the messages are generated using the editor and the CAP message is saved, then the Relay component will generate the necessary and sufficient outputs in the specified file formats. Thereafter, these files will be relayed to the registered gateways. In most cases it will be a TCP/IP file transfer that will be picked up by the provider. The module will provide means to configure the message relay component. This will entail mapping the CAP message file formats with the respective Gateways. Hence, this component will also allow the user to register and configure the gateway (teleport). The providers will deliver the messages to the last-mile.

11.10. Closed User Group Digital Audio Broadcasting

It is recommended that Sarvodaya explore the feasibility of establishing its own national radio network as a value added programming service to the WorldSpace component of the HazInfo Project.

This project highly emphasizes “Early Warning” stage communications. However, the project also sees importance in the HIH being able to function before and during response and recovery stages of disasters. A number of the ICTs rely upon terrestrial infrastructure backbone networks that could be impacted by hazards. Two ICTs provide alternate means to communicate between the HIH and villages and are not dependent upon terrestrial networks. These are the expensive VSAT system and the WorldSpace satellite systems. Of particular interest are the WorldSpace audio broadcast capabilities. The project has tested a digital radio channel for normal programming including test transmissions in Sinhala, Tamil, and English with instructions that can be easily recorded and transmitted via the project’s own, “Sarvodaya Talk” 950 World Space audio channel.

Initial tests indicate that it's feasible for Sarvodaya to operate the "Sarvodaya Talk" audio channel on a 24/7 basis; particularly for communicating to villages during response and recovery phases of a disaster. The difficulty is absorbing the high cost of the WorldSpace channel. However, if Sarvodaya can devise an appropriate business plan, it may be able to recover the cost from the various Sarvodaya Units such as "Information Technology Unit", "Economic Enterprise Development Services", "Shanthi Sena", "Suwadana Centers" and other Sarvodaya programs by charging a nominal fee to broadcast news and their educational and other programs directly to the communities based on fixed weekly-program. For example, the SNeHA Project is an effort to strengthen health services in Sri Lanka by establishing ICT infrastructure for eHealth and enhancing capacity of healthcare workers in over a dozen of the districts. The project used a WorldSpace solution, namely the AREA-A with datacasting, in its eLearning Design and Development component. The system has proven to work well for conducting distance education. The project foresees using the AREA-A units in the Sarvodaya District Centers for conducting distance learning programs that can also be conducted from the HIH or any location with high-speed internet. Some of the cost can also be absorbed from the users.

To facilitate this technically, a small audio mixer and recording system needs to be installed in the HIH control room to ensure high quality and consistent recording levels. HIH staff also requires basic training in audio production techniques including scripting, audio recording and editing, announcing and on-air presence.

12. TECHNICAL ANNEX 1: LIST ACRONYMS AND ABBREVIATIONS

Table 3 List of acronyms and abbreviations used in this report

AC	Alternate Current
AREA	Addressable Radio for Emergency Alerts
CAD	Canadian Dollars
CAP	Common Alerting Protocol
CB	Cell Broadcasting
CBM	Cell Broadcast Message
CDMA	Code Division Multiple Access
dB	Decibels
DB	Database
dBm	Decibels referenced to one mill watt
DC	Direct Current
DEWN	Disaster and Emergency Warning Networks
DEWNS	Disaster and Emergency Warning Network Software
DRC	Disaster Risk Communication
DWRR	Disaster Warning Recovery and Response
EOI	Event of Interest
ERP	Emergency Response Plan
ERP-C	Emergency Response Plan Coordinator
FXP	Fixed Phone
GSM	Global Standard for Mobile Communications
HIH	Hazard Information Hub
HIH-M	Hazard Information Hub Monitor
HW	Hardware
ICT	Information Communication Technology
ICT-G	Information Communication Technology Guardian
IPAS	Internet Public Alerting System
J2ME	Java 2 Micro Edition
KASP	Knowledge, Attitude, Skills, and Practice
LKR	Sri Lanka Rupees
LM-HWS	Last-Mile Hazard Warning System
MOP	Mobile Phone

NEWS	National Early Warning System
NEWS:SL	National Early Warning System Sri Lanka
PC	Personal Computer
PRA	Participatory Rural Appraisal
PSTN	Public Switch Telephone Network
RAD	Remote Alarm Device
SCDMC	Sarvodaya Community Disaster Management Center
SMS	Short Message Service
SMSC	Short Message Service Center
SW	Software
TOT	Training of Trainers
USD	United States Dollars
VSAT	Very Small Aperture Terminal
WiFi	Wireless Fidelity

13. TECHNICAL ANNEX 2: WHAT IS A COMMUNITY-BASED LM-HWS

Figure 17 illustrates the systems of an end-to-end early warning system. The paper noted that although the issuing of public hazard warnings was the responsibility of the government, it is unlikely that the Last-Mile of such a system can be provided solely by government. Rather, it requires a partnership of all concerned including government, private and non-government sectors.

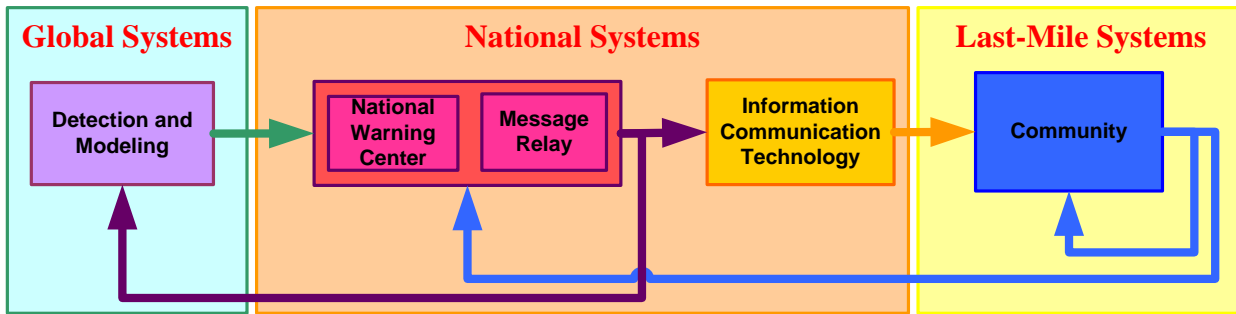

Figure 17 System architecture of an end-to-end hazard detection and warning chain of systems

The LM-HWS architecture depicted in Figure 18 complements the traditional public alerting system design usually established by local and/or national governments. A traditional public alerting system issues warnings directly to communities via broadcast media such as television and radio, or through designated public address (PA) systems. By contrast, the LM-HWS project architecture establishes a closed user group of first responders, who are equipped with addressable wireless devices for receiving bulletins issued from Sarvodaya’s Hazard Information Hub.

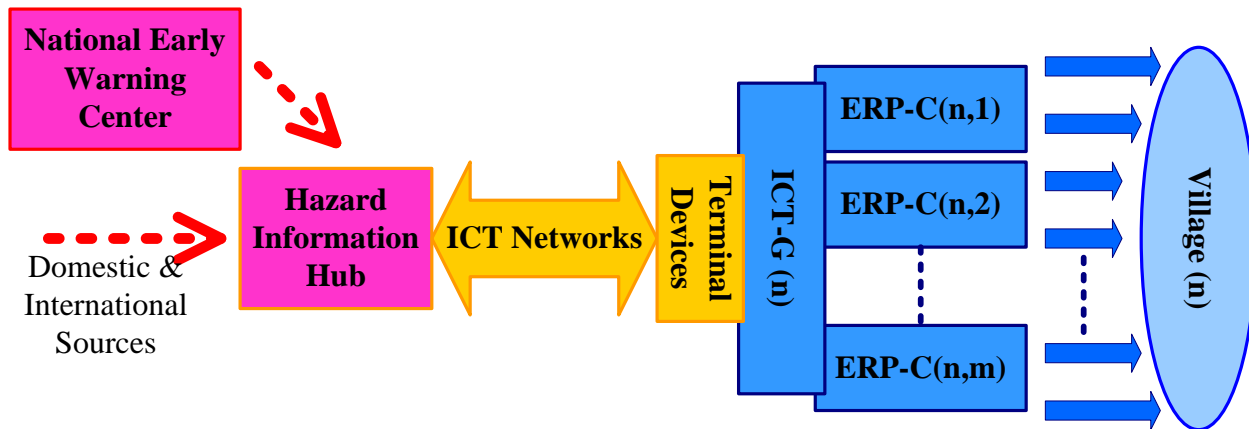

Figure 18 Community-based Alert and Notification communication architecture

For testing purposes the LM-HWS was to design to replicate the components of the typical NEWS; i.e. a system equivalent to an end-to-end early warning system excluding the “detection and modeling system”, illustrated in Figure 17. The reader can map the components in Figure 18 to the subsystems in Figure 17 using the color scheme used to exemplify the identities. For research purposes the closed user group based system illustrated in Figure 2 will provide the identical functions of the NEWS,

which is an aggregate of the National and Last-Mile Systems. Hence, the model in Figure 2 is an ideal replica to test the functional performance of envisaged NEWS.

A simplified information flow for the LM-HWS is as follows: staff members (HIH-Monitors) at the HIH monitor hazard events around-the-clock using the Internet. When a potential threat is detected by an HIH-Monitor (HIH-M), the HIH activates its Emergency Response Plan (ERP) by issuing a message to the n -number of communities at risk using a combination of wireless ICTs to reach local first responders (denoted by the arrow between the HIH and ICT-G blocks in Figure 10). Each community has assigned a person or persons to be responsible for managing the wireless device and monitoring it for incoming warning messages. This person has received training from Sarvodaya and is designated as a community ICT-Guardian (ICT-G). When the ICT-G receives a warning message at the HIH, they are responsible for activating the community-level ERP. The community response will vary depending on the content of the message, including its priority level. During activation, the ICT-G informs the m -number of ERP Coordinators (ERP-C), consisting of a First-Aid team, Evacuation team, Security team, and Message Dissemination team. The Message Dissemination team then relays the message village-wide through various methods, including as word-of-mouth, ringing local temple bells, loudspeaker, and so forth.

Message content is encoded using Common Alerting Protocol (CAP), an open source data interchange standard that includes numerous fields intended to provide consistent and complete messages across different technologies. The implementation of CAP in the LM-HWS is an important aspect of the project because it is key in establishing an “all-media” warning capability. Section V describes the implementation strategy of CAP in Sri Lanka.

14. TECHNICAL ANNEX 3: INTERNETWORKING PIPES, AND GATEWAYS



Figure 19 Microwave Internet link



Figure 20 VSAT Internet Link

Initiating point of internetworking is the HIH. The message composed by the authorized user: HIH Monitor is delivered by Internet Browser based applications or telephony. There are two internet access paths: 203.888.69.241 Speedcast VSAT, Figure 20, or 202.69.197.113 Dialog Microwave links, Figure 19. The VSAT 2.4m satellite sits 2m above ground in the front of the SCDMC building and the Microwave antenna erected 7m above ground at the back of the SCDMC building. VSAT faces east

towards the AsiaSat II satellite and the Microwave antenna faces North towards the closest base station in Kalubowila. Both links are connected to the 16 port CISCO Layer 3 switch sitting inside the HIH and they are patched such that the HIH PCs operate through the VSAT link and the rest of the users in the SDCMC building use the Microwave link. In the event the VSAT link goes down then the microwave link can be patched to HIH PCs. VSAT provides 512Kbps capacity and the Microwave link offers a 228Kbps capacity. The VSAT hops from the HIH avoiding any other communications infrastructure in Sri Lanka to Hong Kong. The VSAT has been proven to work on UPS power when main grid power had been halted. Figure 21 illustrates the primary internet access gateways; i.e. the yellow boxes.

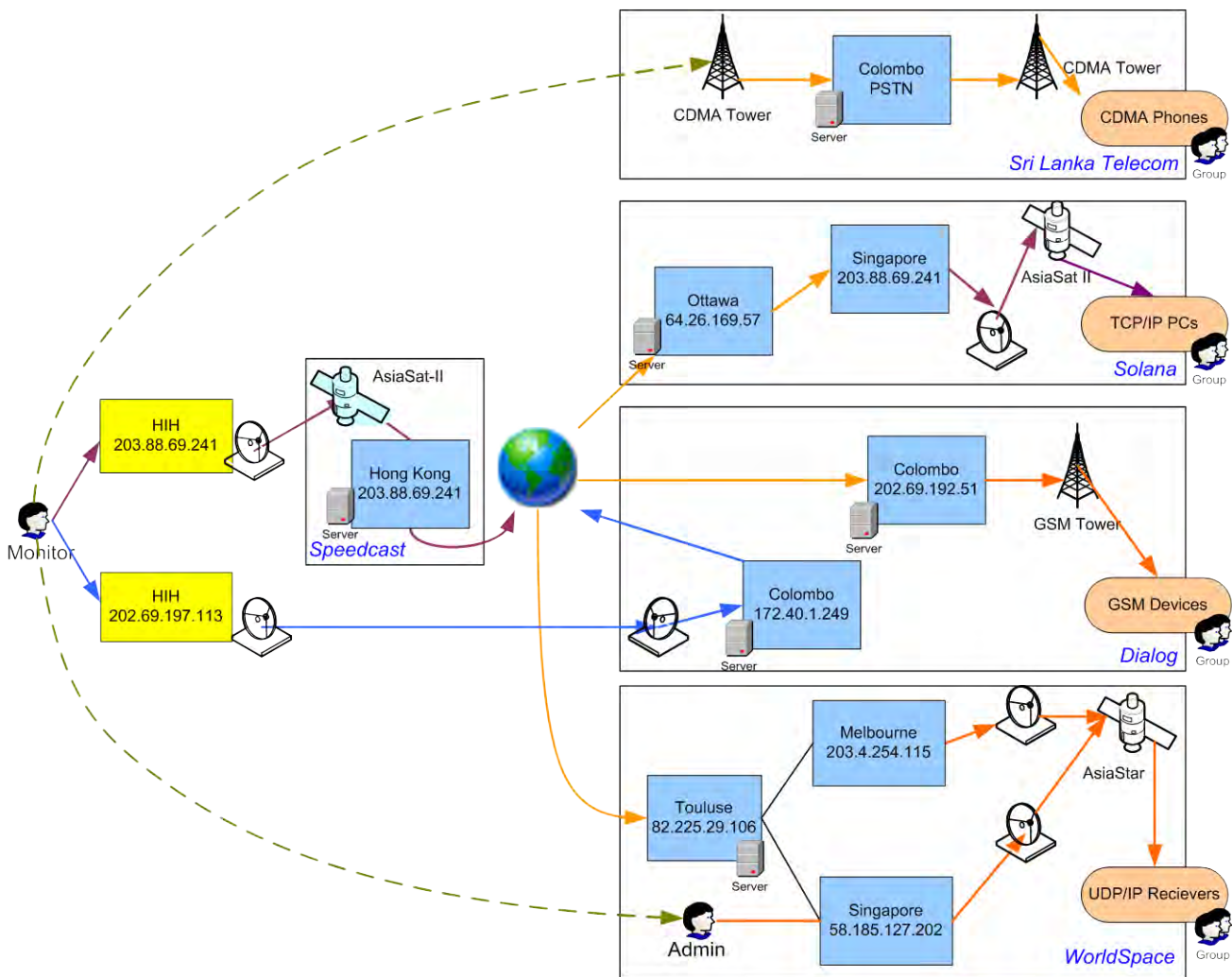

Figure 21 ICT providers, gateways, and technologies linking HIH with the Last-Mile

Through the Web based applications: ANNY, DEWN, and IPAS the HIH can issue text messages to the WorldSpace, Dialog, and Solana Networks gateways. The HIH also has Landline, CDMA and GSM telephony for voice communication or issuing of fax. In the event the Internet fails then the HIH

will use the telephony to reach the overseas hubs such as the WorldSpace stations in India or Singapore, Solana Networks in Canada to help issue the messages. The internet based IPAS would still fail if Internet in the entire country is ill-fated. However, the satellite based WorldSpace receivers will still be functional. Same applies to the Dialog system, which can be accessed by an overseas of authorized party with access to the internet and the application can issue a message, which can be received on the RAD and Mobile Phones as they both work on the SMS platform.

As illustrated in Figure 21 the WorldSpace system has several redundant paths and gateways to uplink the alert messages to the AsiaStar satellite. Once released from the satellite, as long as the terminal devices on ground are operational, the messages will be received within 7 seconds. The Dialog system uses their terrestrial GSM network to deliver the alert messages to each of the targeted RAD and Mobile hand held. Solana Networks uses the TCP/IP internet to send and receive alert messages. The CDMA telephony system uses the PSTN and the CDMA terrestrial network to communicate via voice.

15. TECHNICAL ANNEX 4: RESEARCH MATRIX AND ICT ALLOCATIONS

Table 4 Village categorization relative to the training regime and organizational ranking

<i>Quadrant</i>	<i>Village characteristics</i>
Upper Left	- Given ERP Training and they are Less Organized (level 1,2,3) Communities
Upper Right	- Not given ERP Training and they are Less Organized (level 1,2,3) Communities
Lower Left	- Given ERP Training and they are Organized (level 4) communities
Lower Right	- Not given ERP Training and they are Organized (level 4) communities

Table 5 The deployment of ICT combinations in the 32 selected Sarvodaya communities

VSAT Urawatha (Galle)	MOP Nidavur (Batticaloa)	FXP Thirukadala r (Trincomale)	AREA Moratuwe lla (Colombo)	MOP Meddhawat ha (Matara)	MOP Thamiluvil (Kalmunai)	FXP Oluville (Kalmunai)	AREA Maggona (Kalutara)
AREA + RAD Modara- pallassa (Hambantota)	AREA + FXP Wathagama North (Matara)	AREA + MOP Palmunnai (Batticalo)	Control Village Abeyasinghe Pura (Ampara)	AREA + RAD Thondama nar (Jaffna)	AREA + FXP Shithanikudipuram (Kalmunai)	AREA + MOP Munnai (Jaffna)	Control Village Modara (Colombo)
VSAT Modaragama (Hambantota)	MOP Diyalagoda (Kalutara)	FXP Periyakallar (Batticalo)	AREA Panama North (Ampara)	MOP Satur- kondagnya (Batticallo)	MOP Samodhagama (Hambantota)	FXP Indivinn a (Galle)	AREA Brahama- a-wattha (Galle)

AREA + RAD Kalmunai II (Kalmunai)	AREA + FXP Samudragama (Trincomalee)	AREA + MOP Valhengoda (Galle)	Control Village Mirissa South (Matara)	AREA + RAD Venamulla (Galle)	AREA + FXP Kottegoda (Matara)	AREA + MOP Thallala South (Matara)	Control Village Thalpitiya (Kalutara)
---	---	--	--	---------------------------------------	--	--	--

Communities (District defined in parenthesis) that participated in the Last-Mile HazInfo Project. Table is subdivided in to 4 quadrants with 8 villages in each. VSAT – very small aperture terminal, MOP – mobile phone, FXP – fixed phone, AREA – Addressable radio for emergency alerts, RAD – remote alarm device, and Control Village – community without an ICT. The other literals that are different from the acronyms: VSAT, MOP, FXP, AREA, and RAD along with the Control Villages in Table 5 are the names of the community; where the literal in the “()” is the name of the District the community belongs to. A combination of the ICTs were tested among 28 ICT-G (32 communities minus 4 control villages). This allows the project to scrutinize the most user friendly combination of ICT for the ICT-G in Sri Lanka; where the performance of the HIH-M and ICT-G is not restricted to 1 ICT.

Table 6 Synopsis of Sarvodaya development stages

<i>Development Stage</i>	<i>Description of organizational (development) level</i>
Stage 1	Inquiry from the village and organization of an introductory <i>shramadana</i> camp for the village, during which problems are analyzed together and needs identified.
Stage 2	Establishment of various groups (children's, youngsters, mothers' and farmers' groups), construction of a child development center, and training of staff.
Stage 3	Program for meeting the basic needs and setting up institutions (including the founding of the Sarvodaya Shramadana Society, which is responsible for the village's development initiatives);
Stage 4	Measures to produce income and employment; establishment of complete self-reliance and self-financing;
Stage 5	Support for other village communities.

16. TECHNICAL ANNEX 5: CALCULATING THE EFFICIENCY OF PROCESSES

Let t_i be the time of process $i=1,2,\dots$ is actually initiated; where $E(t_i)$ is the expected time at which the process should have been initiated and t'_i is the time process i is terminated and $E(t'_i)$ is the time the process is expected to be terminated. Further introduce a variable indicated in equations (1) and (2):

$$T_i = t'_i - t_i \quad (1)$$

is the time interval taken to complete process i ; where

$$E(T_i) = E(t'_i - t_i) \quad (2).$$

Figure 22 illustrates the three main time intervals T_0, T_1, T_2 evaluated in this project. The difference of the hazard initiating time and the hazard impact time is defined as the period T , which varies for the

combination of each hazard-category and event. Usually the event information will inform the hazard travel time. A good message will contain the event information such as the vector (speed and direction) of hazard as well as the time and location of the event. Therefore, the calculation of the minimal allowable period is obtained by applying equation (3):

$$T = d/s \quad (3)$$

where d is the minimum distance between epicenter and impact area and s is the speed at which the hazard is travelling.

Reliability of the processes are measured as a function of time that it takes to complete the sequence of processes such as the HIH Monitor relaying alerts to the Last-Mile, Community-First-Responder relaying alerts to the ERP-Coordinators, and activating local ERP as illustrated in Figure 18. Efficiency is calculated by applying the equation (4):

$$R_i = 1 - \left(\frac{T_i - E(T_i)}{T} \right) \quad (4)$$

when $T_i > E(T_i)$; otherwise $R_i = 1$ because the process was completed prior to the anticipated time. Similarly, the other extreme is for two consecutive processes (example: $i=1 < j=2$) from the set of processes; when $t_i > t_j$, then $R_i = 0$ because the process has surpassed the maximum allowable time for that process to complete.

Figure 22 illustrates the sequence of functions involved with issuing an alert message to the last-mile communities. The had segregated the entire communication sequence of functions in to three processes: HIH Monitor, ICT, and Community. As labeled in Figure 22, the time periods T_0, T_1, T_2 correspond to the three processes. The time stamps were recorded at several intervals of the sequence to estimate the efficiency of each of the processes.

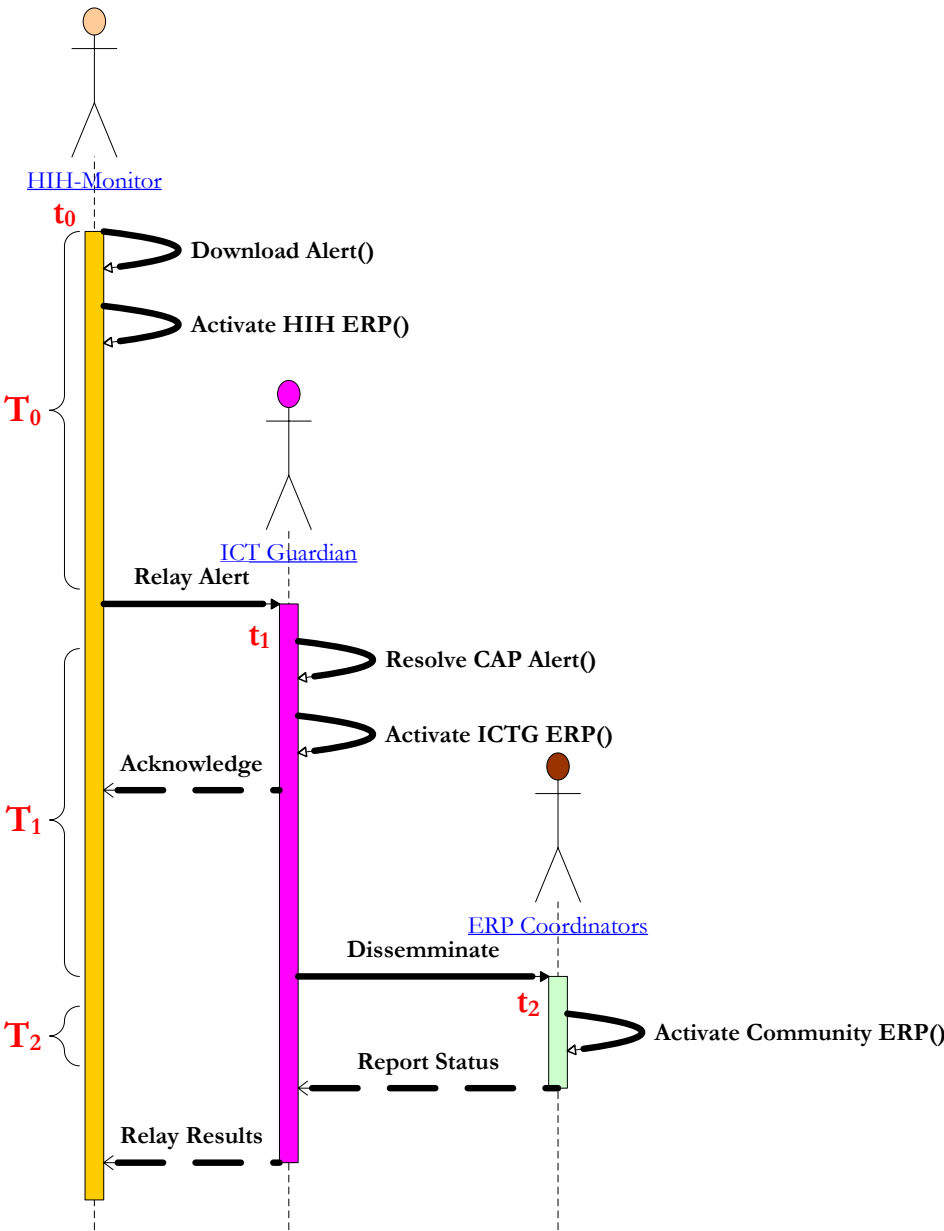

Figure 22 Sequence diagram of the actors and associated functions of LM-HWS

17. TECHNICAL ANNEX 6: MEASURING EFFECTIVENESS OF THE HIH AND COMMUNITY

Effectiveness of the HIH and Community is a measure of the HIH-M and ICT-G capability to encode and decode a CAP message. In the case of the HIH-M they should be capable of transforming any bulletin received from an external source to fit the form of a CAP message. This task is done with the aid of a form called the “EOI” (Event of Interest) shown in Appendix J. The EOI form contains all the attributes of a CAP message and is concarted in a way to assist the HIH-M with the task of encoding a CAP message. The form has a set of check boxes for each of the CAP “qualifier” elements (i.e. header of the <alert> segment, see Figure 41). By simply ticking the correct check boxes that correspond to the set of predefined values, the HIH-M can determine the appropriate values to pupulate the qualifier elements. The difficulty is in populating the <info> segment for each of the languages in the CAP Profile (see Figure 41). The <info> segment cannot be neglected because it carries the important elements that describe the priority of the alert message. Although the CAP ontology allows the <info> section to be optional the CAP Profile for Sri Lanka makes it a mandetory element. HIH-M will extract this information from the bulletines to the best of their ability. Never the less, in all cases the entire payload of the bulletin received at the HIH will be implanted in the <description> element. Apply Table 9 in section 20.2 to obtain a real valued score for the HIH-M’s effectiveness to complete the CAP message with the essential elements.

The ICT-G must be capable of interpreting the CAP message received from the HIH and most importantly be able to determine the priority of the message, which is determined by reading the <urgency>, <sevierity>, and <certainty> elements embeded in the CAP <info> segment. In the absence of the <urgency>, <sevierity>, and <certainty> elements, the ICT-G must be capable of identifying the information for these elements from the <description> element of the CAP message. ICT-G were provided with a paper form: Alert Log (Datasheet 1 in Appendix J), which contained the essential elements needed for documenting the CAP message. The same Alert Log would provide them with the tools to extract the priority and description of the alert message. Once again by applying the methodology described in section 20.2, a real valued measure for the ICT-G effectiveness can be obtained from Table 9.

ERP-C are expected to activate all their ERPs with respect to the Hazadous event invloving the activation of the local dissemination teams, first-aid teams, security teams, and evacuation teams. They are further expected to clearly and accurately deliver the information related to the incident as well as cover all the households in their juresdiction.

18. TECHNICAL ANNEX 7: CALCULATING RELIABILITY OF ICT

The basic question governing the reliability measure is “did the ICT based system work on the day of the live-exercise?” Reliability, denoted by R can be measured in at least two aspects: *certainty* and *efficiency*; denoted by R_c and R_e respectively. Whereas certainty refers to the operational state of a device on the day of the exercise, efficiency measures the time taken to complete the transmission of a message in relation to the anticipated hazard risk (i.e., will the message be received with enough advance warning to take action?).

Applying equations (4) for efficiency to the ICT segment of the sequence and equation (6) for the certainty of ICT, the overall reliability R of the wireless ICT in a LM-HWS is computed as functions of the certainty and efficiency of the ICTs; as given by equation (5):

$$R = R_c \times R_e \tag{5}$$

18.1. Certainty of Message Receipt

Enumaeration of the Effectiveness Parameter: Signal Strength in Terminal Devices

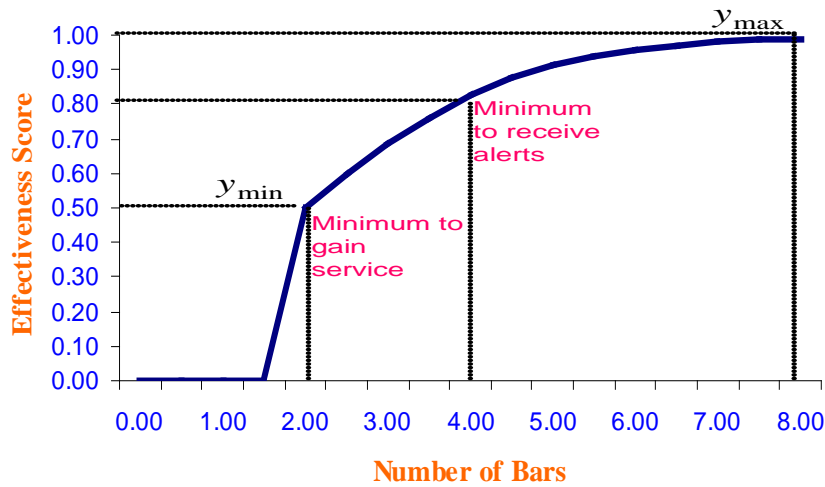

Figure 23 Graph for calculating the effectiveness based on signal strength

In some situations the ICT failed on the day of the exercise and was given a reliability score of 0 in terms of certainty. It was evident that the strength of the signal coverage was catalyst to an ICT-G undoubtedly receiving an alert. Signal coverage measures the certainty of a message reaching an ICT-G recipient at various times of day and is intended to reflect the variability between mobile, nomadic, and fixed wireless devices. Signal strength is important for the Alerting feature because if the signal is weak then some data can get lost. As a result the terminal device may not get the full bit string, causing failure to activate some of its active alerting function sensory features that are triggered by designated bits in the data string.

Wireless signal is usually measured as a function of the power of the signal in decibels (dB) then referenced to 1 mill watt (dBm). The signal strength was measured at the ICT-Gs home or the location where equipment was installed. A GSM mobile phone can function on -104 to -47 dBm range, Satellites operates on -127 to -60 dBm range, and CDMA phone operates on -106 to -48 dBm range. All the devices used in the project display their signal strength using illumination of histogram bars (or LEDs) that are a function relative to the dBm range of the device.

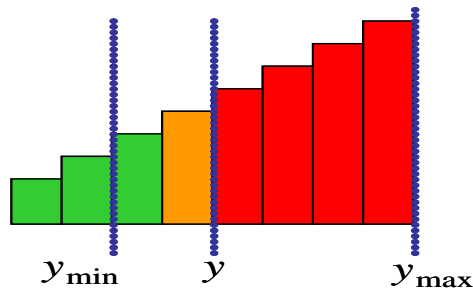

Figure 24 Example of signal strength bars

Given the device has a total of y_{\max} bars, at a particular location such as the ICT-G’s home, the device may have $y \leq y_{\max}$ number of bars illuminated; where y is a real number.

EXAMPLE 2: A particular terminal device may have the bars color coded; where a green bar implies full strength, amber bar implies half strength, and red bar implies zero strength. As illustrated in Figure 24, a color coding for a device with a maximum of 8 bars having 3 green bars, 1 amber bar, and 4 red bars illuminated may imply signal strength of $y = 3.5$.

For a particular application of the ICT (e.g. application of sending and receiving SMS) to work properly the service provider can specify a minimum requirement for the signal strength (such as 1 bar). Let us denote this minimum strength by y_{\min} . The device is given a score based on the signal strength indicated by the bars by applying equation (6):

$$R_c = \begin{cases} \frac{1}{1 + e^{y_{\min} - y}} & , y \geq y_{\min} \\ 0 & , y < y_{\min} \end{cases} \quad (6)$$

The exponential function defined in equation (6) and shown Figure 23 will give a score between 0 and 1 for certainty. When $y = y_{\min}$ the score will be 0.5, implying that with the terminal device indicating minimum signal strength there is only a 50% chance that the alert message will come through without any doubt. As the number of signal strength bars: $y > y_{\min}$ increase the score will reach a value of 1 at an exponential rate. Similarly as the number of bars decrease below the minimum number of bars needed the probability of receiving the alert drops below 50 percent.

The calculation takes in to consideration that $y_{\max} - y_{\min} \approx 5$ because all of the ICT terminal devices tested in this project had either a 5 bar or 7 bar signal strength display; where all of the devices with 5 bars required approximately minimum application specific requirement of 2 bars and the devices with a 7 bar display required approximately a 3 bar minimum requirement. It is evident that the signal strength scoring equation (6) has to be refined and generalized for all ICT terminal devices. For the purpose of this research equation (6) was sufficient. The authors recognize that equation (6) does not take in to considerations of uncertainties caused due to operator (human) mishaps that are discussed in section 3.1.

18.2. Efficiency Measure of Transmission

Equation (4) estimates the efficiency of the ICTs in terms of a time taken to transmit the message from the HIH to the ICT-G. The time period begins when the HIH-M starts entering the message in the web based application or started dialing the phone and the time period ends when the ICT-G guardian completes recording the message in the Alert Log (Datasheet 1, Appendix J).

19. TECHNICAL ANNEX 8: MEASURING EFFECTIVENESS OF THE ICT

19.1. Effectiveness of the Individual ICTs

Effectiveness was measured as a function of a set of discrete parameters. The project has defined 11 such discrete parameters: language diversity, full CAP capability, audio and text medium availability, bi-directionality, total cost of ownership, DC power consumption, daily utilization, acknowledgement of message receipt, active alerting functionality, weight of wireless ICT, and volume of terminal device. Each parameter is denoted by a literal q_1, q_2, \dots, q_{11} . A continuous function or “Liken” type rating (i.e. discrete function) is defined and applied to obtain a real valued score between 0 and 1 for each literal, which is denoted by $P(q_i)$ for $i=1\dots 11$. A conjunction of the literals $q_1 \wedge q_2 \wedge \dots \wedge q_{11}$ defines the design requirement for an effective ICT in a LM-HWS. Hence, a single score for the effectiveness G of the deployed wireless ICT configuration is obtained by multiplying the real valued score of all the literals, as stated in equation (7).

$$G = G(q_1) \times G(q_2) \times \dots \times G(q_{11}) \quad (7)$$

The 11 parameters are further grouped in to 5 cliques: CAP Completeness, Two-way, Adoptability, Miniaturization, and Alerting; as shown in Table 7, which is not listed in any particular order as their contribution to effectiveness in a Community-based LM-HWS is equally important.

Table 7 Cliques and the set of corresponding parameters

<u>Clique</u>	<u>Parameter description</u>	<u>Abbreviation</u>
Adoptability	Integration in to daily life or development practices	Utilization
	Total cost of ownership of ICT services and terminal device	Affordability
Alerting	Acknowledgement of message receipt	Accountability
	Active alerting function	Wakeup
CAP Complete	Language diversity	Ethnicity
	Full CAP capability	All-media All-hazards
	Audio and Text mediums of communication	Multimedia
Miniaturization	Weight of wireless ICT terminal devices	Weight
	Dimension of wireless ICT terminal devices	Volume
	DC power consumption	Longevity
Two-way	Upstream and Downstream communication	Bi-directionality

The researchers believe that it is better to scrutinize the effectiveness in terms of discrete cliques: G_1, G_2, G_3, G_4, G_5 opposed a single real value G because in cases such as the AREA which is one-way broadcast technology would score a 0 in terms of two-way capability and would drive the overall effectiveness score $G=0$ and hide the true capabilities in which the effectiveness of the technology ranks very high in all other capabilities.

19.2. Effectiveness of a Combination of ICTs

As shown in Table 5 of the research matrix, fourteen communities were equipped with two ICTs. When measuring the effectiveness for the combination of ICTs (i.e. two or more) the maximum value of the particular parameter of the set of ICTs is taken as the value for the set. Let $j=1,2,\dots,m$ be the set of ICTs; where $G_j(q_i)$ be the real value effectiveness measure for literal q_i . Then $\{Max(G_j(q_i))_{j=1,2,\dots,m}\}$ is the effectiveness measure for the combination of ICTs.

20. TECHNICAL ANNEX 9: FUZZIFICATION OF FULL CAP COMPLETENESS

In this project we define a Complete Full-CAP Message to be one that complies with the CAP Profile for Sri Lanka, contains all three languages: Sinhala, Tamil, and English, and also is disseminated in modes of Audio (i.e. Voice) and Text. The final rating is the multiplication of the values obtained from Tables 2, 3, & 4.

20.1. CAP Profile for Sri Lanka

CAP adopts a Document Type Definition (DTD) Extensible Markup Language (XML) data structure that consist of a main element <Alert> and subelements <Info>, <Area>, and <Resources> as illustrated in Figure 41 in Technical Annex 15. The <urgency> code denotes the time to impact of the event. <severity> codes denotes the scale of impact of the event. <certainty> Code denotes the probability of the event. These 3 elements define the Priority of the <event>. The Priority is a higher order function that maps Urgency, Severity, and Certainty values to a distinct Priority: Urgent, High, Medium, or Low. The mapping is discussed in Table 8.

Table 8 Matrix to determine Message Priority with CAP elements

Priority	<urgency>	<severity>	<certainty>
Urgent	Immediate	Extreme	Observed
High	Expected	Severe	Observed
Medium	Expected	Moderate	Observed
Low	Expected	Unknown	Likely

The reader may refer to the “Guidelines for the HIH in Technical Annex 15 to fully comprehend the CAP Profile for Sri Lanka, which elaborates each of the elements and defines the set of predefined values for the for the elements with fixed set of values.

20.2. Compulsory Elements of the CAP Profile

A CAP message is defined to have a high effectiveness value of 1 if the message contains all CAP elements described in Tables 20 - 23 in Technical Annex 15. The lower end value 0 is when the message is an empty CAP message; i.e. dead air or text elements with null values. The compulsory Elements of the CAP Profile include elements in the <Alert> “qualifier” elements: <Incident>, <Identifier>, <Sender>, <Sent>, <Status>, <msgType>, <Scope>, and the “sub” elements: <Info>, <Resource>, and <Area>. Table 9 defines the discrete function which enumerates the capability of a technology.

Table 9 Scaling function for Full-CAP Capabilities

<i>Value</i>	<i>Fuzzy Rules</i>
1.00	All sub elements that are contained in the <Alert> element, which includes all the qualifier elements and <info> element as well as the <resource> and <area> sub elements
0.95	Mandatory elements described in the Profile for Sri Lanka, which are qualifier elements in the <alert> segment and the sub elements of the <Info> element with at least the <urgency>, <severity>, <certainty>, and <description>
0.85	Elements of the <alert> segment and the <info> sub element <description> only
0.70	<description> only
0.50	Elements <category> and <event> only
0.25	Mandatory sub elements of the <alert> segment only
0	Otherwise

20.3. Language Diversity in Sri Lanka

The function to enumerate the language diversity is obtained by applying basic set theory. The $[n]$ set of linguistics recognized and used in a area (community, state, province, country, or region) with a population set X , the literals $L_i(X)$ define the subset of the overall population that can speak, read, and write the language i ; where $i = 1, 2, \dots, n$. For two languages $i, j \in \{1, 2, \dots, n\}$: $L_i(X) \cup L_j(X)$ is the subset of the total population that can speak, read, and write either or both languages. The ideal case is the technology having the capability to carry alert messages in all the languages covering the entire population in the targeted area; consequently would score 1. The lower end score of 0 is given to a technology that would cover none of the languages applicable to the area in which the alert messages are issued to. Let $[m] \subseteq [n]$ be the set of linguistics of the universal set for linguistics applicable to the area. The real value calculated from equation (8) gives a score between 0 and 1 indicating the fraction of population “covered” by the subset of language relative to the overall population.

$$\frac{|\bigcup_{j \in [m]} L_j(X)|}{|X|} \tag{8}$$

The rules in Table 11 are constructed from equation (8) by applying the Ethnicity Statistics⁷ obtained

⁷ Statistics used in the explanation was obtained from -- <http://www.statistics.gov.lk/census2001/population/district/t001c.htm> ; the

from the Census Bureau of Sri Lanka; approximately 82% are Sinhalese, 17.3% are Tamil (Sri Lanka Moor, Sri Lanka Tamil and Indian Tamil), and the rest, 0.7% are Other (Burgher, Malay, Sri Lanka Chetty, Bharatha, etc). “Other” ethnic groups are literate in English and in a major portion of them can speak and read either Sinhala or Tamil. The Census Bureau provides data on the ability of an ethnic group’s literacy in the secondary languages. Table 10 is an extract of the data distribution by ethnic group, which is used to generate a Venn diagram to obtain the necessary counts for the language sets: Sinhala, Tamil, and English. Since the percentage of the population who are literate in all 3 languages is relative very small, an assumption is made that the size of this set is 0.

Table 10 Percentage of population by ethnic group (race) literacy in the second languages

Race →	Sinhala		Tamil		Other	
Literate in →	Tamil	English	Sinhala	English	Sinhala	Tamil
Percentage →	3.00	9.83	15.00	5.00	0	0

The percentage3 calculated in Table 10 is with respect to the overall population and not relative to the race. The statistics relative to each race is given in the data sheet provided by the census bureau. The notation in the column fuzzy rule: Sinhala + Tamil + English imply the set union of the populations speaking Sinhala, Tamil, or English.

Table 11 Scaling Function for Language Diversity

<i>Value</i>	<i>Fuzzy Rule</i>
1.00	Sinhala + Tamil + English
0.99	Sinhala + Tamil
0.95	Sinhala + English
0.80	Sinhala Only
0.38	Tamil + English
0.28	Tamil Only
0.15	English Only
0	Otherwise

20.4. Mix of Pictorial, Audio and Text Communication Mediums

The project used Table 12 to weight the ICT as a function of the capability to disseminate pictorial, audio or text messages. The context of *pictorial* refers to a message depicted by a photograph, digital image, or non alphanumeric symbol that can be interpreted clearly and accurately as a warning message. The message must be able to provide the necessary and sufficient set of risk information or guide towards an alternate source to fetch the full set of information. The picture may contain text in one or more languages to describe the scenario. A simple example is a Satellite image of cyclone on a map with the direction of movement indicated by an arrow and the category indicated by a color. An audible message such as what one would receive from a radio broadcast, public announcing system, or television news cast are considered as *audio* messages. The medium of *text* is the use of alpha numeric

values used for Rural and Urban as a collective.

characters (numbers and language alphabet) to communicate the alert message. Computers use a standard called Unicode to define characters of a particular language where the Unicode maps to a hexadecimal value that can be interpreted by any electronic processor.

Television is a terminal device that is capable of simultaneously communicating via all three mediums. Digital radios such as the AREA device used in this project can deliver both audio and text. The SMS based alerting technique via mobile phone is only capable of text messaging.

Table 12 Scaling Function for Audio and Text Communication Mediums

<i>Value</i>	<i>Fuzzy Rule</i>
1.00	Pictorial + Audio + Text
0.95	Pictorial + Audio
0.90	Audio + Text
0.80	Audio
0.70	Pictorial + Text
0.60	Pictorial
0.50	Text only
0	Otherwise

21. TECHNICAL ANNEX 10: FUZZIFICATION OF ALERTING PROCESS

The project defines *alerting* to be a function where a pictorial (image), written (text) or voice (audio) message is relayed to a Community-First-Responder (person manning the ICT device); in this project it would be via an ICT device belonging to the Community-First-Responder. Simple issuing the message alone is inadequate. Therefore, the Alerting function is complete if the message is received by the Community-First-Responder and the Community-First-Responder returns an acknowledgement message via same or alternate path to the Sender at the Message-Relay.

The sequence of functions are 1) Hub Relays a message in CAP format to the ICT Providers 2) ICT Provider resolves message and transmits to the respective devices 3) devices receive alert 4) device activates wakeup function 5) Community-First-Responder acknowledges message by turning off wakeup function 6) device auto-transmits or Community-First-Responder sends acknowledgement to ICT Provider's database 7) on demand Acknowledgement Report made available for Message Sender. Figure 22 in Technical Annex 4 illustrate the sequence of functions and the actors: HIH Monitors and ICT Guardians associated with carrying out the function.

As described by the cliques in Table 7 in Technical Annex 8 the project has defined the following functional indicators: Message Receipt Acknowledgement (accountability) and active alerting (wakeup) to assess the effectiveness of the ICT as an Alerting tool.

21.1. Acknowledgement of Message Receipt

Message receipt acknowledgement is vital for the message Community-First-Responders to inform the Sender that the message was received. In the context of Alerting the acknowledgement must be initiated by a human. Hence, the devices must have a method in place to send an acknowledgement as soon as the Community-First-Responder accepts the message. The Message Receipt an Acknowledgement is a Probability function anchored on the time taken between Alerting functions 1) and 7). The device would score 1.0 if the acknowledgement was reported in less than 1.0 minutes; score 0.95 if it took less than 5.0 minutes; score 0.85 if it took less than 10.0 minutes; score 0.70 if it took less than 20.0 minutes; score 0.50 if it took less than 45.0 minutes; score 0.25 if it took less than 90.0 minutes. The probability density function defines a sigmoid shaped discrete scaling function; where the score is higher if the time taken to report acknowledgement was almost instantaneous.

Table 13 Scaling Function for Acknowledgement of Message Receipt

<i>Value</i>	<i>Fuzzy Rules</i>
1.00	< 1.0 min
0.95	< 5.0 min
0.85	< 10.0 min
0.70	< 20.0 min
0.50	< 45.0 min
0.25	< 90.0 min
0	Otherwise

21.2. Wakeup function to gain attention

Wakeup function is designed to draw the attention of the targeted Community-First-Responders with a combination of attention-getters: sounding-sirens, flashing-lights, or mechanical-vibrations. Basically the Wakeup feature should actuate the aural, visual, and sensual sensors of the Community-First-Responder. The ICT device scores 1.0 if it has all three attention getters; scores 0.95 if it has a Siren and Light because this combination does not require the device to be attached to the Community-First-Responder in any way; scores 0.85 if it sounds a siren only; scores 0.70 if it sounds a siren and vibrates; scores 0.50 if it activates a flashing-light and vibrates; scores 0.25 activates only one a flashing-light or vibrates; scores 0 otherwise. For a person fast asleep simply a flashing light alone will not get the attention of the sleeping person and needs an "Alarm" sound to wake them up. When defining the wakeup function for people with disabilities then the manufacturer must use the best attention getter to suit the requirement. Figure 26 describes the function for enumerating the ICT's effectiveness to wakeup the ICT-G based on the visual, audio, and tactile sensory.

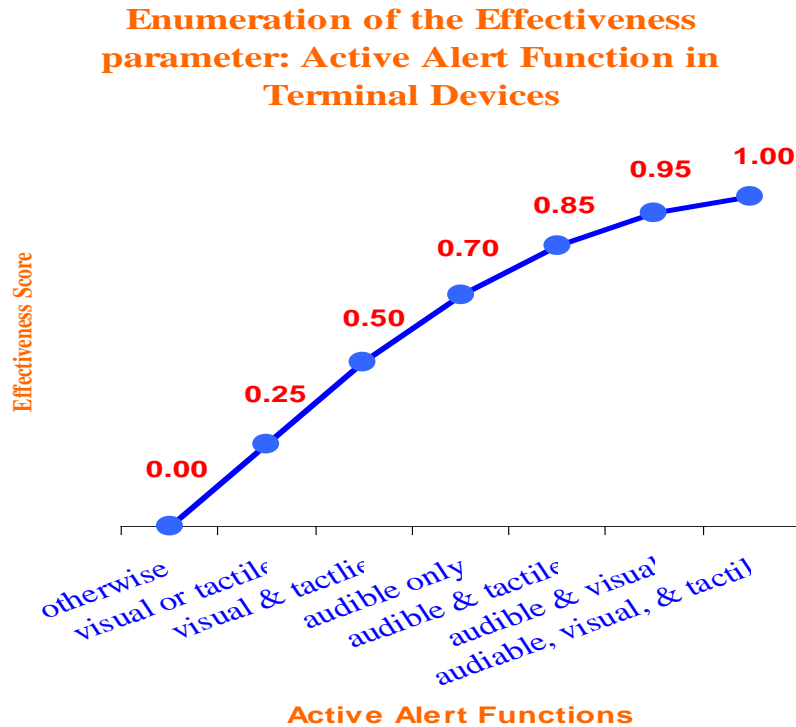

Figure 25 Enumeration function for wake up function

22. TECHNICAL ANNEX 11: FUZZIFICATION OF TWO-WAY COMMUNICATION

22.1. Bi-Directionality for Upstream and Downstream Communication

Bi-Directionality is an indicator to measure the ability of the device to permit upstream communications from local communities to the Message Relay as well as downstream communication from the Message Relay to the Communities. The upstream communication is mainly for Last-Mile Communities to inquire-of and report situations affecting their communities. The MOP, FXP, and VSAT allow both upstream and downstream communication without any restriction. The RAD has limited the upstream communication such that the user can “call back” only when an alert is received. The AREA does not allow any upstream communication at all. Once again each of the devices is given a score on a scale of 0 to 1 such that if it has no restrictions then it scores a 1.0 and a lower score for all other combinations giving prominence to (i.e. higher score) for downstream communication over upstream communication in the domain of community-based alert and notification. Table 14 provides a discrete enumeration method to give a real valued score to an ICT based on the upstream and downstream communication capabilities.

Table 14 Scaling Function for Bi-directionality

<i>Value</i>	<i>Rules</i>
1.00	Upstream and Downstream No restrictions
0.95	Downstream and restricted Upstream
0.85	Downstream only
0.70	Restricted Downstream and Upstream
0.50	Upstream only
0.25	Restricted Downstream and Restricted Upstream
0	Otherwise

23. TECHNICAL ANNEX 12: FUZZIFICATION OF ADOPTABILITY

23.1. Integration of ICT in to Community daily life

Integration in to daily life is basically a utilization measure. Utilization can be quantitatively measured in terms of time spent or monthly cost or both. However, there are non holistic measures that can give greater value to the ICT being adopted such as the WorldSpace radio channel that can be used for community development, which may have a greater impact to the entire community opposed to a mobile phone also adoptable for community development but on an individual basis. Similarly the VSAT that gives access to the internet, email, and VoIP cannot be measured on time alone because the utility is based on several applications that cannot be ranked on importance.

To measure the utilization the Communities were given a daily journal to record the usage. The main variable governing the assessment is time spent by the user and the purpose of use as to how it may be beneficial.

23.2. Total Cost of Ownership

There is a hardware and service cost associated with owning and operating a personal communications technology. The hardware and service costs are further partitioned as fixed cost and variable cost, which gives rise to four parameters as described in Table 15. Although the hardware can guarantee usage for five years, it is standard business practice to linearly depreciate electronic hardware over three years. Therefore, the total cost of ownership is anchored on the hardware and service costs over a three year period. In the Community-base hazard information dissemination model a single ICT deployment, comprising one or two terminal devices, is to cover the entire community. Therefore, the TCO is uniformly distributed amongst the number of households; i.e. TCO is divided by the number of house holds.

Table 15 Parameters associated with calculating TOC

	Fixed cost	Variable cost (per month)
Hardware	Purchasing the terminal device: H_{fc} ; brand new or second hand cost of the ICT	Warranty, maintenance, licensing fees: H_{vc} ; i.e. usually there is some kind of a recurring cost, let say the owner decided to insure the hand set pay a premium on a monthly basis
Service	Entry fees or setup fees: S_{fc} ; person has to purchase a sim card, assume they throw away the sim when they throw away the phone in 3 years	Periodic subscription or rental charges: S_{vc} ; assuming it is a pre paid, the person has to top it up on a monthly basis

In the attempt to devise a method to calculate the TCO the following assumptions are taken in to consideration:

- 1) “Community-based” early warning systems are for developing nations where governments in these nations neither have the capacity nor have the motive to deliver the public good to their citizens; therefore, the community takes the initiative to link with an alternate source through ICTs
- 2) More than 50% of the population in developing nations are in socio economic classes D & E; therefore, the solutions proposed must be affordable to them
- 3) Calculating the TCO based on the data available for D & E provides a good lower bound for the average TCO for an ICT in a community-based early warning system for that nation
- 4) The minimum number of households per community is $N = 100$
- 5) Equation (9) is an appropriate formula to calculate the TCO for a community for a period of 3 year

$$\text{Per household three year TCO} = \frac{(H_{fc} + S_{fc} + (H_{vc} + S_{vc}) \times 36)}{N} \quad (9)$$

EXAMPLE 3: The project extracted the values for the fixed and variable costs for the hardware and service variables from the paper “Teleuse on a Shoestring”⁸; $H_{fc} = 95$, $H_{vc} = 0$, $S_{fc} = 15$, and $S_{vc} = 7.23$. The information is based on year 2006 survey data. The average monthly expenditure S_{vc} for Sri Lanka is calculated as an average of pre-paid mobile owners, post-paid mobile owners, and home fixed phones. From the figures in the survey we can obtain that the price of a brand new unit is USD 95. One time entry fee to obtain a service is USD10. For the real data and applying equation (9) we obtain the TCO to be USD 3.70 per community house hold over a period of three years. The TCO lower bound is obtained from information related telephony, which may seem unbiased when using the TCO value to weigh ICTs such as the VSAT or AREA.

Let us assume the benchmark TCO per community to be $E(C)$; where $E(C) = 3.70$ as calculated in Example 3. Let C denote the TCO of the particular ICT. Equation (9) defines a penalty function, which describes a quantified effectiveness score for the TCO:

⁸ H. de Silva, A. Zainudeen, (January 2007), “Teleuse on a Shoestring: Beyond Universal Access”, CPRsouth, can be found here -- <http://www.cprsouth.org/index.html/files/Session%205,%20Paper%201,%20January%2019,%202007%20-%20Ayesha%20Zainudeen.pdf>

$$G(C) = \begin{cases} 1 & C \leq E(C) \\ \frac{C - E(C)}{E(C)} & C > E(C) \end{cases} \quad (10)$$

The graph in Figure 27 describes the basic shape of the function defined by equation (9) for the Sri Lankan case.

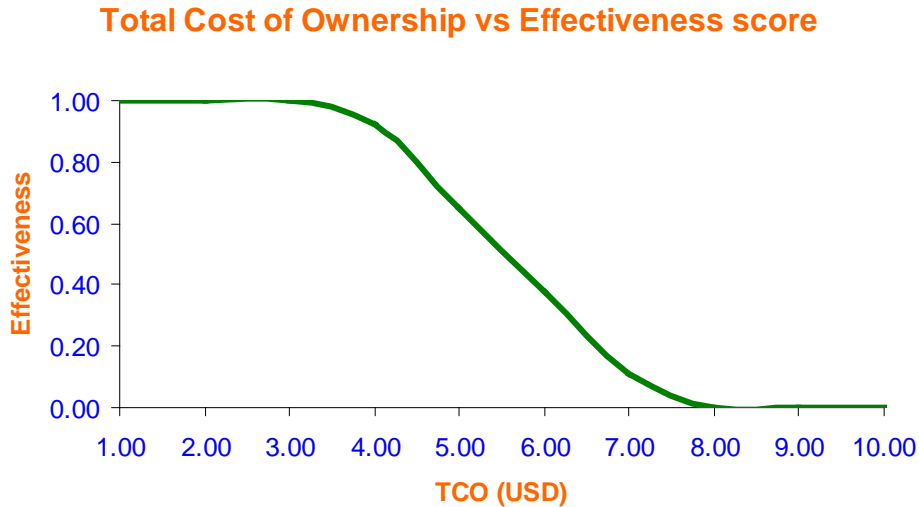

Figure 26 Graphs of TCO penalty function

24. TECHNICAL ANNEX 13: FUZZIFICATION OF MINIATURERIZATION

The Community-based early warning equipment are not restricted to alert and notification but are expected to be a valuable communication source throughout the entire disaster management cycle of mitigation, relief, and recovery. Relief workers are often called upon to perform their duties in remote areas which are not served by telecommunications or where networks have been destroyed. Coordinating aid efforts and keeping in touch with fellow workers, informing central authorities the state of affairs of the community are vital to the rapid delivery of assistance where it is most needed. Hence, the project belief is that the terminal devices used for alert and notification must be easily portable to strategic locations and be rapidly deployable. The trend in the world is to build electronics as small and practical as possible. The same notion is envisaged in terminal devices designed for communication in disaster management. As a result the project has identified weight, volume, and longevity as parameters that measure what is termed as miniaturization. The key factor of transportability is a function of the parameters weight and volume of the communications device. Where as rapid deployment (free of infrastructure) and uninterrupted service becomes a function of the longevity (available power).

24.1. Weight of the entire functional unit

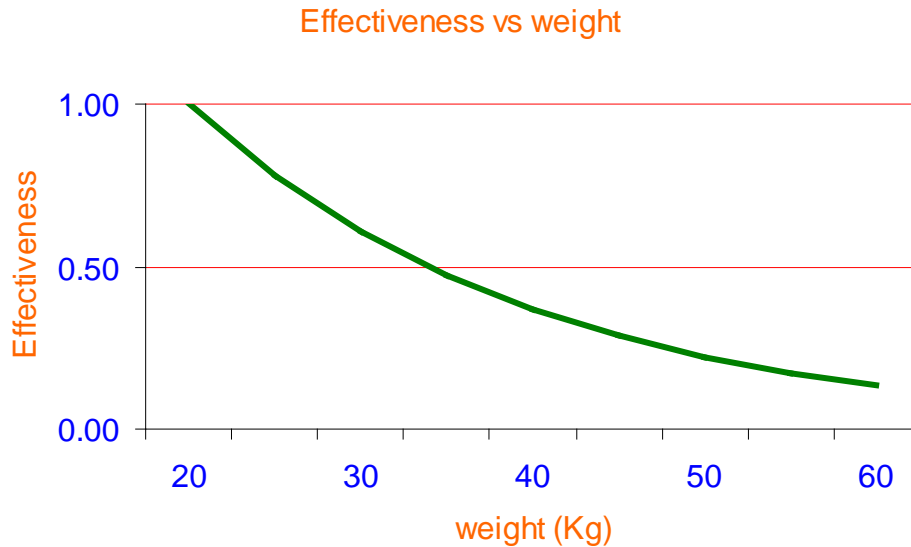

Figure 27 Graph of the equation (11) for weights above 20Kg

The weight must be below what an average adult human being is capable of carrying. The project sets a standard for the load a human being, without special skills, can carry to be 20 kilograms. If the terminal device is over 20Kg, then the effectiveness of the device in terms of weight is penalized and given a score between 1 and 0. If the device weighs less than or equal to 20Kg then it will receive a full score of 1. A weight of 30Kg is bearable and a single person can carry. However, when the weight is beyond 40Kg it becomes intolerable for a single person to carry. The project devised a penalty function that exponentially decreases the effectiveness score as the weight increases beyond 20Kg.

$$G(W) = \begin{cases} 1 & W \leq 20 \\ e^{\frac{1}{20}(-W+20)} & W > 20 \end{cases} \quad (11)$$

The penalty function, described by equation (11), is devised in a way to reduce the effectiveness exponentially because the intention is to minimize the number of resources allocated to the tasks such as transporting and operationalizing the communications during a crisis situation. When the weight is 30Kg the effectiveness is 0.6 above 0.5 and as the weight is beyond 35Kg the effectiveness score depreciates below 0.5 and approaches 0 rapidly there on. The reciprocal of the effectiveness score can be interpreted as the number of people required to carry the equipment; i.e. when the weight is over 35Kg, $\frac{1}{G(35)} = 2.12 \approx 2$, at least 2 people are need to carry the equipment.

24.2. Volume of terminal device and peripherals

The Volume parameter will be associated with the mathematical context of a “packing”; where the object with a specific volume must meet certain criteria and as a result would score a high or low probabilistic value. Volume dimensions of the entire device, including all parts necessary for it to be fully functional, must be such that the device can be placed in a space without extra long pieces

protruding making it difficult to transport or place in an indoor/outdoor environment. For example, there are standard set of dimensions that go to make up a total volume of 114cm where length, width, and height, approximately, is 56 x 35 x 23 cm, respectively, for airline carryon luggage. Similarly, a constraint is set that the dimensions terminal device with shapes like a prism, a cuboid, a sphere, or ellipse, must be less than or equal to 0.5 meters. The value 0.5 is chosen such that the object (terminal device) can easily fit in a suitcase or backpack that can be easily carried by hand or on the shoulder in a back pack.

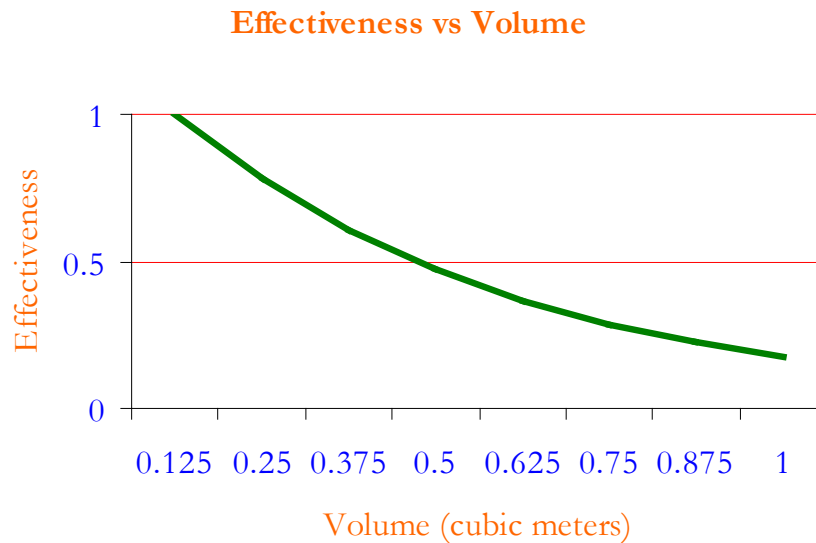

Figure 28 Graph of equation (12) for volume above 0.125m³

Since it is inappropriate to compare two objects, the diameter of a sphere against the diagonal length of a cuboid, for example, to judge a winner, the project has chosen to compare the volume given that that any dimensions contributing to the volume must be less than or equal to 0.5 meters. Thus the maximum volume of a spherical object will be approximately 0.06m³ or the maximum volume of a cuboid will be 0.125m³. From geometry or packing theory it is known that amongst three dimensional objects the cube with length l has the largest volume of all the geometries such as a prism, sphere, or ellipse with same dimension of maximum size l . Similar to the weigh penalty function described by equation (11), the linear penalty function (12) is devised for the volume:

$$G(V) = \begin{cases} 1 & V \leq 0.125 \\ e^{2(-V+0.125)} & V > 0.125 \end{cases} \quad (12)$$

Any thing in between 0.125 and 0.250 will get a score between 0 and 1 depicting the effectiveness in terms of volume. The same argument as in the case of the weight applies here; where $1/G(V)$ implies the number of individual maximum volume containers: suitcase or backpack required to haul the equipment; i.e. $1/G(0.5) = 2.12 > 2$ requires at least 2 containers.

24.3. Longevity of operational state

Longevity is included as part of the set measuring miniaturization because the operational life span is dependent upon the rate of power consumption and capacity of the power source of the wireless technologies. All the electronics of the communications devices work on Direct Current (DC) power. The duration of the DC power source is relative to the capacity of the battery powering the device and the rate at which the power is consumed by the circuitry. All ICTs except the VSAT, tested in the project, were equipped with rechargeable batteries, which could be charged via Alternate Current (AC) from the main power grid or via solar power. The 20 – 40 watt VSAT modems can be powered by high capacity batteries. A device powered by AC can be regarded as having an infinite longevity (immortal), assuming the service of power is uninterrupted. AC is converted to DC before electricity flows through the electronics. When main grid AC power is interrupted then the device will switch to the charged battery power.

Manufacturers are compelled by IEEE standards to specify the input voltage, acceptable range of the current, and the power consumed by the apparatus. From the theory of electricity it is known that power is equal to the voltage multiplied by the current. Moreover, current is the rate at which a charge flows though a point in a electric circuit. Given the capacity of the battery, the utilization time of the battery (i.e. battery life) can be calculated.

The project set the standard that each wireless device must function for a minimum of 16 hours on battery. Assuming the battery can be charged using solar during daylight and the minimum requirement for the strength of sunlight is available for 8 hours, the unit must function for the remaining 16 hours on battery over the 24 hour period.

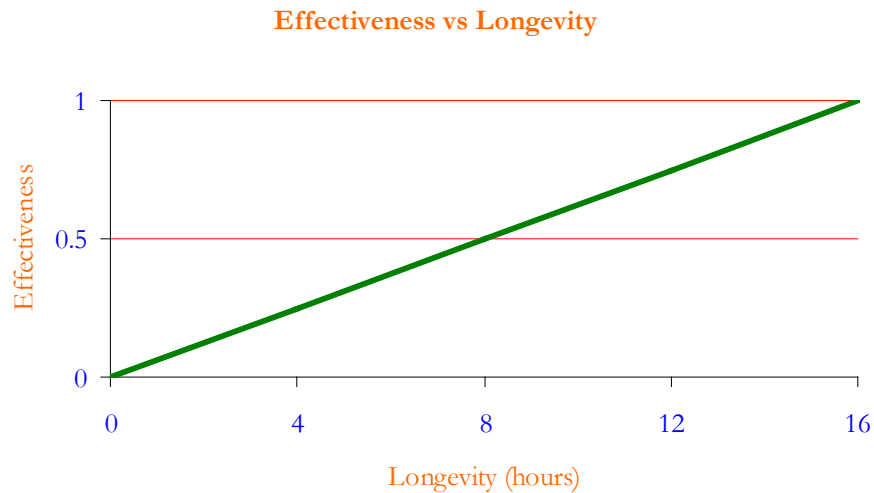

Figure 29 Graph of equation (13) from 0 to 16 hours

Let L be the battery life and $G(L)$ be the effectiveness measure for operational longevity of the ICT; where $G(L)=0$ if the battery has 0 capacity; i.e. 16 hours and $G(L)=1$ if the battery life is over 16 hours. The linearly depreciating penalty function is given by equation (13):

$$G(L) = \begin{cases} 1 & L \geq 16 \\ \left(\frac{L}{16}\right) & L < 16 \end{cases} \quad (13)$$

Equation (9) is linear because the battery power is assumed to drain uniformly. As shown in **Figure 7** the reciprocal of the effectiveness $\frac{1}{G(L)}$ can be interpreted as the number of batteries required to sustain the ICT for 16 hours. A battery with a 4 hour life span: $\frac{1}{G(4)} = 4$ implies that 4 batteries are required to keep the ICT operational for 16 hours.

25. TECHNICAL ANNEX 14: EXPECTED PERFORMANCE OF THE ICT

25.1. WorldSpace Addressable Satellite Radio System

Transmission Technology

There are two types of satellite transponders onboard the WS satellites, one transparent and the other on-board processed. The Transparent Repeater repeats Time Division Multiplexed (TDM) carriers sent to the satellite from large earth stations at X-band onto downlink carriers at L-band. Each satellite has three spot beams with each beam containing two TDM carriers centered at different frequencies in the band 1452-1492 MHz. Each beam covers a large geographical area and with the six beams on the two satellites in service, the coverage extends to more than 130 countries in Asia, Africa and Europe.

Each TDM carries 1.536 Mbps, divided into 96 Prime Rate Channels (PRC) each of 16kbps. A basic audio program can use just one PRC and achieve an audio quality better than analog short wave as WS uses efficient audio coding scheme MPEG Layer-3. As many as 8 PRCs can form one Broadcast Channel (BC) depending on the desired quality. The WS digital format incorporates interleaving, 255, 223 Reed-Solomon block coder and Rate $\frac{1}{2}$ Vitterbi convolution encoding technologies to protect the service against transmission errors. At any given geographical location, typically 30-40 subscribable audio channels are available, giving the listener enough choice.

AREA Terminal Device Components

The receiver, called DAMB-R2, is a low-memory radio with a small display and a limited processing power. DAMB-R2 features dual channel reception with one of the channels designated as a data channel called OAAC (Over Air Activation Channel). Through the OAAC channel the alert provider can send an alert message. DAMB-R2 has the capability to monitor the alert, validate the message and perform the specified action. The action could range from activating a relay for a siren, turning on/switch to a WS channel for audio messages and displaying text regarding the alert.

An external box can be fitted via a USB to the DAMB-R2 to enhance the display with a larger digital display as well as couple other peripherals such as an audible siren and GPS receiver. A palm-sized linear patch antenna was used to receive the services. All WS specific processing including MPEG decoding is handled by the StarMan chipset, which is incorporated in all the receivers. Each radio

receiver features a BC digital output connector allowing to access to the full content of the selected BC from an external appliance. Figure 30 illustrates all the components associated with the AREA system.

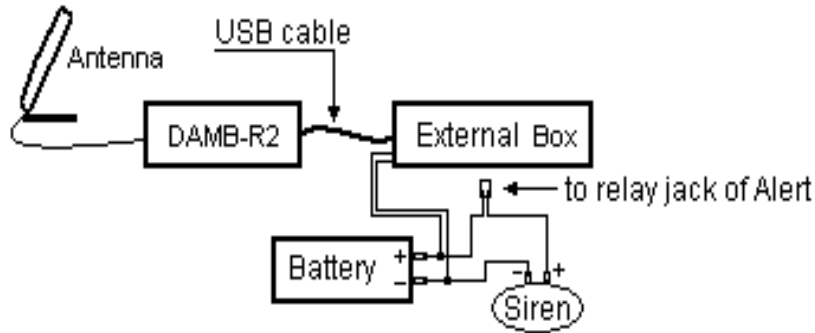

Figure 30 Components of the AREA Terminal device

States of the AREA Receiver

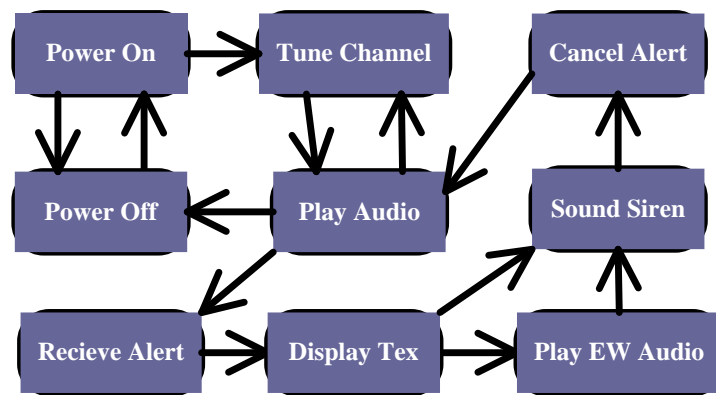

Figure 31 State transition diagram for the AREA systems

After power is supplied, AREA (B,C & M) can be initiated from the *Power Off* state to the *Power On*. At this point any of the available channels can be tuned and it starts *Playing Audio*. The AREA receiver is now ready to receive alerts. Once an alert is received, the AREA normally *Sound Siren* and Display Text of the mandatory elements of the CAP message. In the case the channel ID (BCID) is specified in the CAP message, then DAMB-R2 can be automatically preset to that channel and this can be chosen as the Emergency Warning (EW) broadcast channel. Once the alert cancellation is received, it stops displaying the text and the tuner once again becomes active for selection of the available channels. Figure 31 shows the various operational states of the AREA system.

ANNY Network Interface

The uplink segment includes a special, secure, web interface, hosted at one or more of the designated centers from where the Emergency Warning message is generated; see Figure 14. Additionally, the interface incorporates procedures for authentication and logging of the alerts, generation, uploading and scheduling of transmission of content for the supplementary audio channel that WS supports once an alert is announced, updating an announced alert, canceling the alert, periodic end-to-end testing of the entire system.

25.2. Dialog Disaster and Emergency Warning System

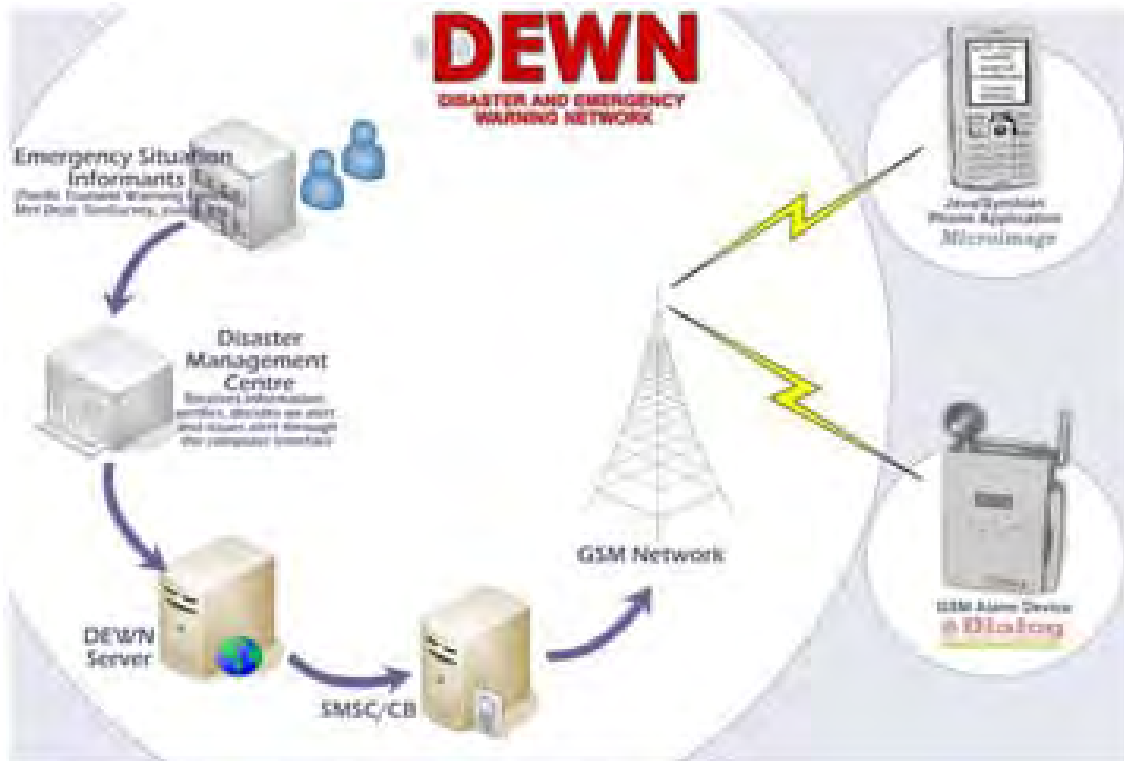

Figure 32 High level architecture of the DEWNS with network and Terminal Devices

The Disaster Emergency Warning Network (DEWN) is based entirely on widely available mobile communications technologies such as Short Messages (SMS) and Cell Broadcast Messages (CBM), aimed at rendering a cost effective and reliable mass alert system. The system is compliant with CAP. As shown in Figure 32, DEWN comprises of two basic elements – i.e. the DEWN Server and DEWN Clients. The DEWN Server will reside in a secure facility and will be used by authorized persons to generate warning messages via SMS or CBM. The DEWN Clients are the intended recipients of the above mentioned messages. Upon reception of the messages the clients will take necessary measures to inform the users of the system about the warning. The DEWN Clients are twofold. They are a Java/Symbian application for mobile phones developed by Microimage and the Remote Alarm Device discussed developed by University-of-Moratuwa Dialog Mobile Communications Research Lab.

Messaging Software Application

At this stage of the project, MicroImage has developed a web browser based CAP GUI; namely the Disaster and Emergency Warning Network Software (DEWNS). The GUI interfaces with the GSM and the Dialog SMS components. The Dialog Telekom SMS servers are registered as teleports in their respective CAP alerting software. SW application for issuing alert messages is accessed via an Internet web-based connection. The authorized user logs in and proceeds through a sequential 3-screen process to create and compose a CAP-compliant message. Presently, the RAD/SMS CAP software, shown in Figure 15, operates independently of other LM-HWS components.

Remote Alarm Device

RAD is based entirely on widely available mobile communications technologies Short Messages (SMS) and Cell Broadcast Messages (CBM). SMS Based alerting is used to activate selected or individual RADs, while the CBM is used to activate all RADs. These terminal devices are stand-alone units that incorporate remotely activated alarms, flashing lights, a broadcast FM radio receiver to be turned off or on as directed by the message, the displaying of the SMS messages on LCD panel, a self-test button, message acknowledgement and a dynamic hotline GSM call-back feature for user to acquire additional information. Five push button switches labeled as Call, Ack, LCD, Test, and Radio control the operational states of the device. The GSM Alarm Device is a product of the University of Moratuwa Dialog⁹ Communication Research Lab.

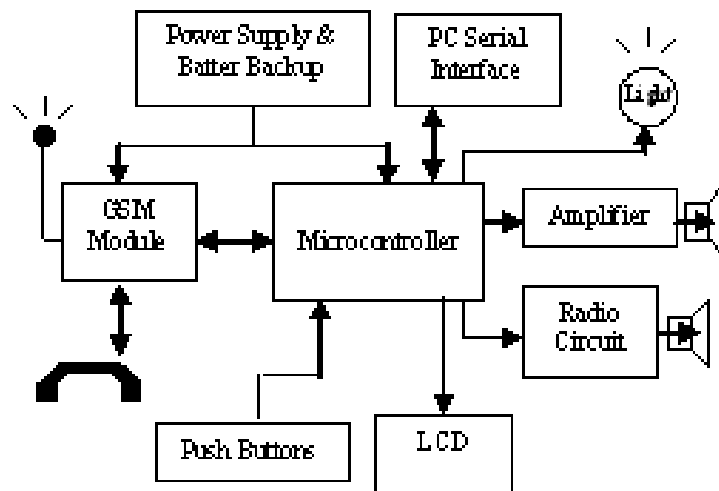

Figure 33 Circuit level system architecture of the RAD

The Microcontroller and the GSM module are the key components of the Alarm Device. The system components are illustrated in Figure 33. The microcontroller houses a multitude of peripheral devices such as internal program flash memory, Data Memory, general purpose I/O, and USARTS. Once in

⁹ Dialog Telekom url on the Disaster and Emergency Warning Network – <http://www.dialog.lk/en/corporate/cr/ourapproach/innovationinclusion/dewn.html>

operation, the GSM module listens for any incoming SMS messages or CBMs. CBM-based warning messages will be broadcast on a predetermined dedicated logical broadcast channel. Upon the reception of a CBM or an SMS, a notification will be sent by the GSM module to the microcontroller. The Microcontroller in turn will read and processes the message. If the message is from an authorized source (in case of SMS) and conforms to a given format the Alarm Device will be triggered. The RAD is designed to power up from the mains supply but is equipped with a seven hour back up battery as a secondary power source.

HazInfo project was the first to field test the RADs. Hence usability and effectiveness of the devices were questionable from the beginning. Having disregarded the issue faced by congestion in SMS applications the units were found to be exceptionally reliable during Lab tests. The external turning-indicator type flashing light used in vehicles and 40watt speaker ranked the RAD to be the unit to have the most forceful active alerting functions. The 160 character limited display designed for English text messaging only established the device to have very low effectiveness. Since the GSM signals cover only 60% of Sri Lanka the units would be limited to locations with good signal coverage. The sets had absolutely no value addition to integrating them in to the village daily life, reducing the effectiveness scores further.

J2ME Applet embedded Mobile Phone

The research used Nokia 6600 MOP that are powered by a 104MHz ARM processor, and is based around Symbian's Series 60 platform. Microimage¹⁰ developed a J2ME applet that sits on Symbian Operating System. The MOPs are activated by a SMS sent from an Internet Application that can be configured to send alerts to all or a group of MOP handsets. The GSM Java enabled SMS mobile phones receive text alerts in Sinhala, Tamil and English, sounds an alarm, and has a hotline GSM call-back feature.

Given that the MOP had java based client software that fulfilled all three features of the active alerting function, as well as text messaging in all three national languages the devices was expected to perform the best with very high effectiveness. Since SMS messaging requires less signal strength opposed to voice the MOP based solution was, further, trusted to be highly effective. The ubiquitous technology with a device that can be alongside the ICT-G at all times and could be easily integrated in to their daily village life would prove to be most reliable device of the lot.

Operational States of the GSM devices

Power On -- the RAD is powered by 240v 60Hz AC and when the main power is down it is run by a Matrix 7v DC Lithium Battery. The Nokia 6600 has a rechargeable 9v Battery. At this point the GSM Module in both devices listen to SMS of the type that are Alerts and be on *Standby*. SMS Alert is a specific SMS with a known header that triggers the device to initiate the Alerting Sequence. The total message is the size of 2 SMS messages; i.e. 2 x 140 7bit characters. *Siren On*, *Light On*, and *Text*

¹⁰ Microimage website – <http://www.microimage.com>

Display are instantaneous. The User can press the “Acknowledge button” to turn the *Siren Off* and *Light off*. The User then uses *GSM Telephony* by pressing the “Callback button” to dial the Alert Sender for direct conversation or to receive a voicemail of the CAP message. Final step is pressing the *Radio On* to listen to an FM Emergency Broadcast Station (not available in the Nokia 6600). This completes the cycle of operational states of the 2 GSM based Terminal devices. Figure 34 shows all the operational states of the MOP and RAD.

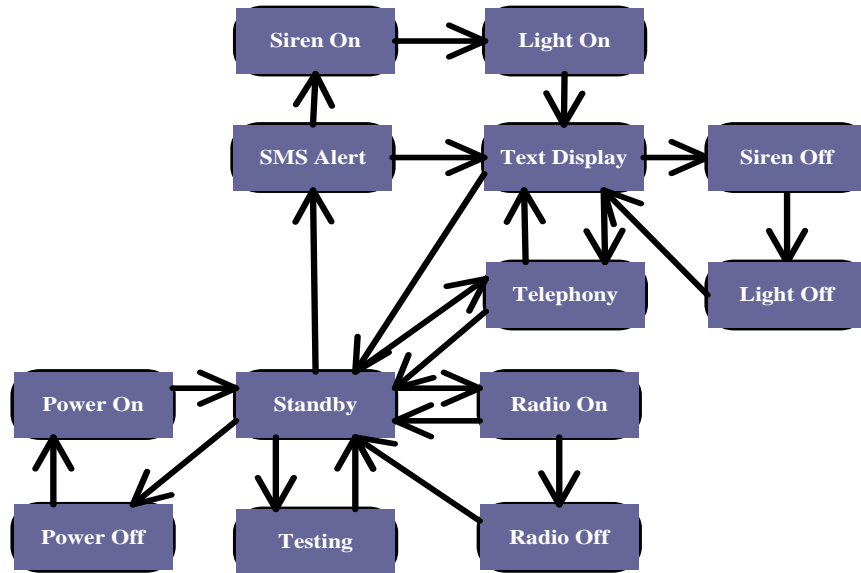

Figure 34 Expected operational states of the RAD & MOP

Encoding and Transmission of CAP Messages

CAP message is entered via an Internet based application: Disaster and Emergency Warning Network (DEWN); namely a HTTP Software Application. The HTTP server strips the *<msgType>* and *<description>* elements of the CAP message. The data is then transformed and packed in to 2 SMS packets and delivers to the Short Message Service Controller (SMSC). This truncated CAP message is then forwarded to the GSM Terminating device: RAD or MOP via the Dialog GSM network.

Reception and Decoding of CAP Messages

The first 140 character 8 bit special SMS text message contains a header code of 10 characters, which is decoded by the RAD’s Microcontroller and by the MOP’s J2ME Applet. Remaining 130 characters contain the text message taken from the *<msgType>* and *<description>* of the original CAP message. The software in the devices activates the alarms of the devices and display the text tripped from the specially encoded SMS packets. The RADs displays only the English portion of the text message; where as the MOPs display the Sinhala, Tamil, and English text messages.

25.3. Solana Networks/Innovative Technologies VSAT/IPAS

VSAT System

VSAT Technology is predominantly used in Sri Lanka for high speed 2-way data exchange, especially satellite Internet access. The LM-HWS uses a star network topology to connect the Sarvodaya Community Disaster Management Center's Hazard Information Hub (HIH) in Moratuwa, serving as the central gateway to interconnect earth stations in Urawatta and Hambantota that serve as nodes. However, the setup also allows any location to serve as the central gateway and, thereby, serving as a back hub site.

The Antenna used at the HIH is a CHANNEL MASTER 2.4 M C-Band linear antenna. The other ground stations use 1.8M C-Band linear antennas. Each antenna are aligned with AsiaSat and are fitted with an AGILIS C-Band BUC and LNB. Two co-axial cables running from the BUCs and LNBs are connected to iDirect 3000 series modems/routers and local network switches.

Internet access via the VSAT system is provided by Speedcast Limited (Speedcast). Headquartered in Hong Kong, Speedcast offers satellite based value added telecommunications services to over 25 countries in the Asia-Pacific region. Speedcast has its regional Network Operations Centre (NOC) located in Hong Kong. The Speedcast NOC is equipped with performance monitoring and network management systems to facilitate problem resolution and is staffed with engineers working 24 hours, 7 days a week, 365 days a year to ensure continuity of services.



Figure 35 Rear of BUC ALB and Front/Rear of iDerct Modem

IPAS Alerting Software Application

Although not CAP-compliant in its present form, IPAS possesses some similar features to CAP. Like CAP-based systems, the IPAS GUI is accessed through a web-based form. The authorized sender logs in and can then select the "Issue Alert" page to begin composing an alert message. Among the features, users can set the send time, duration of the alert, geographic target area, type of message, level of alert, and compose an alert message. The message box feature is equivalent to the message description in the CAP template.

The IPAS Server GUI also allows authorized users to issue hierarchical alerts to subscribers via the Internet. That is to say, alerts can be issued on a national, regional or community wide basis. Further, IPAS alerts can be issued according to a scale of severity from 1 to 5 (5 being the highest severity).

For receiving alerts, IPAS utilizes an alert window, visual and audio approach. Users download and install a Java applet on their computers and then register for the types of emergency alert notifications that they want and can filter them according to geographic scope and severity. In the event of an emergency alert broadcast, the alert message will pop-up in a window on the subscribed user's computer screen with an audible alarm.

IPAS Computer Operational States

IPAS Message Clients were always tested on a Desktop or Notebook computer (PC). The computers were preloaded with Windows XP or Windows Vista Operating Systems. The software is configured to be activated upon PC power up. Thereafter, the IPAS Client prompts the user to *Log In*. After logging in, the IPAS Client runs as a service in the background and is on *Standby* listening to dedicated communication ports for any alerts messages. When an IPAS Alert is received, if configured to *Siren On*, immediately sends a siren sound to the PC speakers and a *Text Display* window pops up on the screen with an Alert Message. After 10 seconds the sound is set to *Siren Off*. The end-users can cancel the Text Display and set the IPAS Client back on standby mode. If the user does not wish to receive alerts then the user can *Log Out*. Also if the PC is being powered down the operating system will force IPAS to *Log Out* before turning the PC Power off.

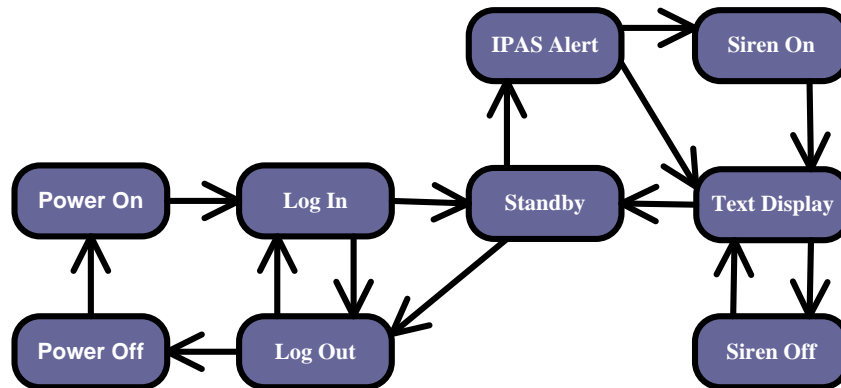

Figure 36 Operational States of the IPAS on a Personal Computer (PC).

25.4. Sri Lanka Telecom Nomadic Telephony System

CDMA Nomadic Phone

The original intention of the project was to use fixed Public Switch Telephone Network (PSTN) lines. However, the infrastructure and capacity does not exist in the rural areas of Sri Lanka; i.e. fixed line network has not rolled out in to rural Sri Lanka. Therefore, CDMA FXP was used in the research, a Sri

Lanka Telecom¹¹ solution called City Link for telephony mainly for Rural Sri Lanka. The phone sets also provide 1xRTT capabilities with Voice, SMS, Fax, and Internet connectivity (54Kbps), which transmit on the 8.5 KHz and 18.5 KHz frequency spectrums. CDMA Fixed Wireless Phones with built-in speakerphones to provide voice communication via the PSTN FXP.

The alerting for was a simple voice call, which would allow for an alert message to be voiced in any language. However, the language diversity of the staff at the HIH would limit the multilingual capabilities. With CDMA coverage spanning all most the entire country it would be highly reliable solution. Loud ring tone is a definite attention getter. However, the nomadic terminal device requires that the ICT-G be in close proximity. Also the if the call is received by the ICT-G, then acknowledgment is instantaneous.

The Internet access of the 1xRTT capabilities were tested from a remote location; where a prepaid card has to be purchased from an SLT outlet and registered through the SLT web portal over the internet. The dilemma is to access the internet via the CDMA phone one must access the internet via an alternate mean to registered the prepaid access information. The CDMA Terminal Device is coupled to a computer via a RS232 serial connector. The TCP/IP must be configured to use “dialup” though a short code. Once connected the bandwidth varies from 36 – 54kbps depending on the signal strength. In order to use the 1xRTT capabilities the Terminal Device must be supplied AC power through the adopter or a 12v DC supply and does not function off the rechargeable battery.

SMS was not tested since the subscribed service package was limited to voice and SMS was not activated. Therefore, the project did not have the opportunity to test alerting over SMS to the FXPs.

Operational States of CDMA 2000 1xRTT Device

In order to power up the CDMA2000 1xRTT terminal device, the unit must be plugged in to the main AC power or the battery must be charged and have minimal capacity. The signal strength must be at least 2-3 bars in order to make a voice call. The standard phone ringing tone gets the attention of the call recipient. The unit has the option of setting 3 different ring tones. When the phone rings (i.e. a call connection being requested) the user picks up the handset receiver with microphone and speaker to talk to the calling party on the other end of the connection; once call is complete either the calling party or receiving party can terminate the call. The terminal unit is on standby waiting to receive a call. The unit can also receive SMS when on standby mode. When a text message is received a ring tone alerts the recipient that a message has arrived. The user can view the message, reply, delete, or navigate away from the SMS display. The user can connect to the internet. While being connected the FXP unit can receive both SMS and Voice calls. Similarly, when on a voice call the FXP can receive a SMS as well as stay connected to the internet. When running on battery power, if the battery capacity is below the minimum charge level, the unit will automatically power off.

¹¹ Sri Lanka Telecom website – <http://www.slt.lk>

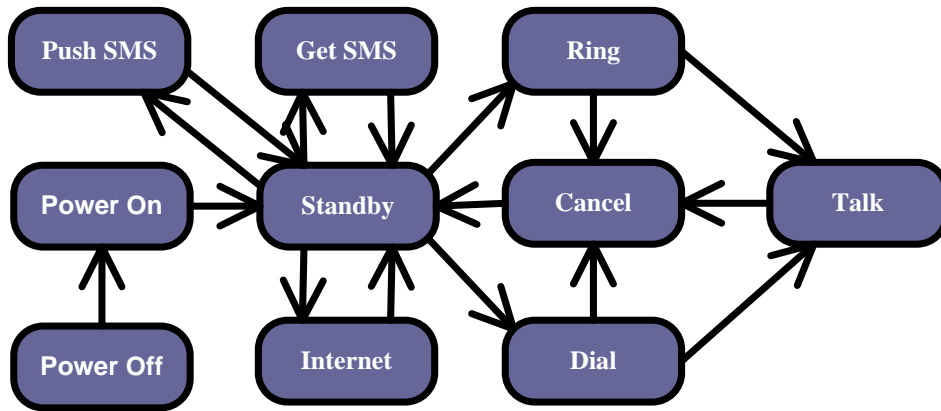

Figure 37 Operational states of 1xRTT CDMA 2000 Unit

26. TECHNICAL ANNEX 15: GUIDELINES FOR THE HIH

26.1. Overview

The LM-HWS is a system for creating and issuing alert messages through the Disaster Management Institute Hazard Information Hub (HIH) to villages belonging the Sarvodaya’s Sri Lanka network. It is important to note that alerts issued by the LM-HWS are not “public” alerts. Instead, the HIH issues alerts to members of a closed user group. The members of the closed user group are designated “first responders” that have been given training by Sarvodaya Shanti Sena (Peace Brigade) and have been trained and certified in conjunction with the Last Mile Hazard Information Dissemination Project. Local first responders are members of the local community and it is they, or their authorized designates, who are responsible for determining if a local, community-wide (village) warning is to be issued. This flow of communications means that the LM-HWS is a two-stage relay network that disseminates information to alert local first responders. These guidelines attend to the First Stage of the LM-HWS only. Training and response plans for local villages are intended to deal with the Second Stage of the system. Figure 38 provides a schematic illustration of the LM-HWS as a two stage relay network.

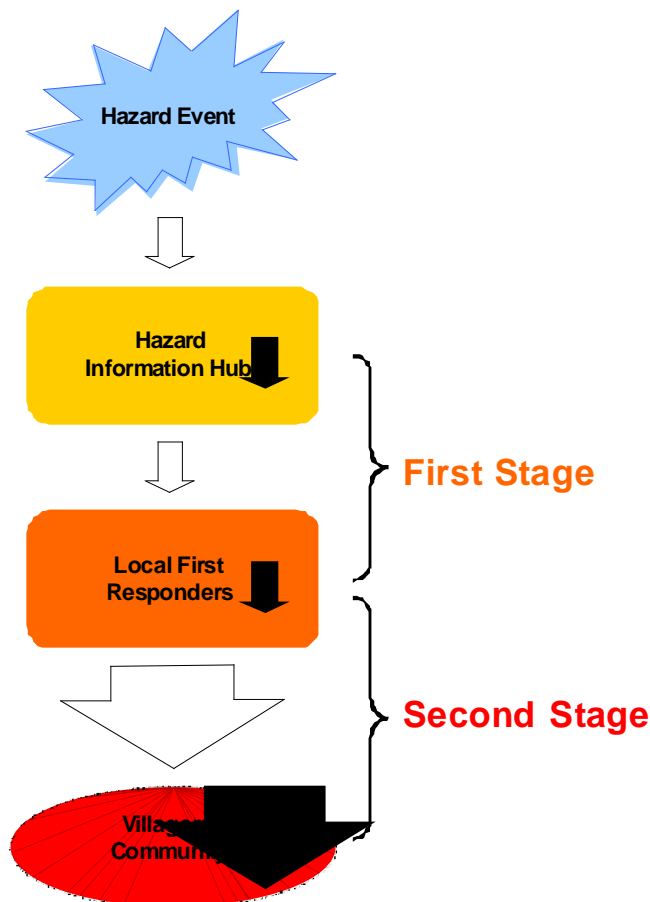

Figure 38 The LM-HWS depicted as a two-stage relay network

26.2. The LM-HWS and its Responsibilities for Issuing Alerts

The HIH and the government

In the event the government of Sri Lanka issues a public warning, the Hazard Information Hub (HIH) will relay this message directly through its network. Local first responders will act on the message as they see fit, but these actions should be based on local response plans and any instructions provided by the government in the initial message or in subsequent public communications (e.g., official messages broadcast by the media).

If the government does not issue CAP-compliant messages, the HIH will need to convert these messages into the CAP format quickly and accurately. If government messages are issued in a standard protocol other than CAP it might be possible to automate the conversion process.

However, in no case should staff at the HIH modify or otherwise revise the contents government message, except to ensure that it is capable of being relayed over the LM-HWS network. In certain cases, the HIH Executive (see below) may direct an Authorized User at the HIH to issue supplementary messages in conjunction with official government warnings.

It is recommended that the optional CAP element <description> be used to relay government warnings in their entirety—if possible, copied and pasted into a CAP message—rather than asking HIH personnel to interpret or to transcribe the message and risk introducing errors in the transcription process.

The HIH and local first responders

The HIH will not issue messages that provide specific instructions to local first responders, except those that might be relayed directly from the government.

Instead, all HIH-originated messages should contain enough information to enable a local first responder to decide if s/he should activate their local response plan based on their training and judgment.

It is the responsibility of the HIH to ensure that all messages sent through the LM-HWS are authorized and conform to an agreed upon CAP Profile Document. These guidelines also establish a CAP Profile Document for the LM-HWS.

Any proposed changes made to the CAP Profile Document that might affect the warning message, or its display on any communications device, must be discussed with training personnel and others involved in the First Stage relay network (including service providers and technology partners).

In the longer term it is anticipated that local first responders will maintain a state of observational readiness and provide information updates to the HIH. These updates will include local reports of hazard impacts or other environmental indicators will serve to provide an upstream flow to support situational awareness at the HIH.

It is also anticipated that a network of automated sensors placed in local communities and other strategic locations will provide some of these upstream flows. In all cases, it is expected that both downstream and upstream messages will be CAP compliant.

Further details on the upstream component will be developed in due course and attached as an addendum to these guidelines.

Local first responders and their communities

It is the responsibility of local first responders to maintain a state of readiness in order to be able to receive messages from the HIH. This state of readiness includes a number of responsibilities. Local first responders must

- Ensure that their local communications equipment is in good operating condition and that battery-operated equipment is adequately charged.
- Ensure that their local communications equipment is “on” and ready to receive messages from the HIH on a 24x7 basis.
- Ensure that at least one authorized person is responsible for monitoring the local communications channel(s) for incoming messages at all times.

It is also the responsibility of local first responders to decide on appropriate action when a message is received. Appropriate action will depend on the information content of the message and the local community response plan. For example, an urgent tsunami warning for the west coast of Sri Lanka might prompt some local villages to activate their evacuation plans while in neighboring villages they activate plans in preparation to receive evacuees.

Again, the HIH will not issue specific instructions to each community but will instead strive to include enough information in its messages to enable local first responders to instigate appropriate action with respect to local response plans.

26.3. Staffing and Training at the HIH

The following chart provides an overview of the organizational structure of the HIH.

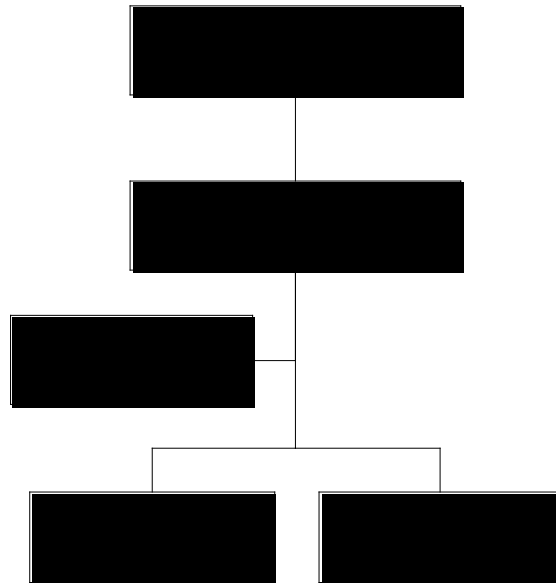

Figure 39 Organizational structure of the HIH

The HIH Executive is responsible for taking decisions to issue or not issue warning messages from the HIH. Members of the executive are senior managers or directors from key stakeholder groups.

The HIH Coordinator is responsible for day-to-day operations of the HIH, as well as for taking a lead role when a decision has been taken to issue warning messages. The Coordinator will be qualified as an “Authorized User” and has the authority to issue warning messages when first approved by the Executive.

The Assistant supports the Coordinator in his/her responsibilities and may or may not be qualified as an Authorized User of the system.

The Monitors are those staff members responsible for tracking and recording details from the various information feeds provided at the HIH. The HIH will be staffed on a continuous basis by at least one Monitor. Monitors will normally also be qualified “Authorized Users,” meaning that they have the authority to compose and issue warning messages when a request to issue a warning is first approved by the Executive.

Support staff include those responsible for upkeep of technology and other equipment at the HIH, as well as those who might be called in to the HIH to provide additional assistance during emergency events (e.g., telephone support) or on an as-needed basis (e.g., during exercises). Support staff may or may not be qualified as “Authorized Users.”

Initiating a warning message

The following flowchart describes the simplified procedure for initiating warning messages from the HIH.

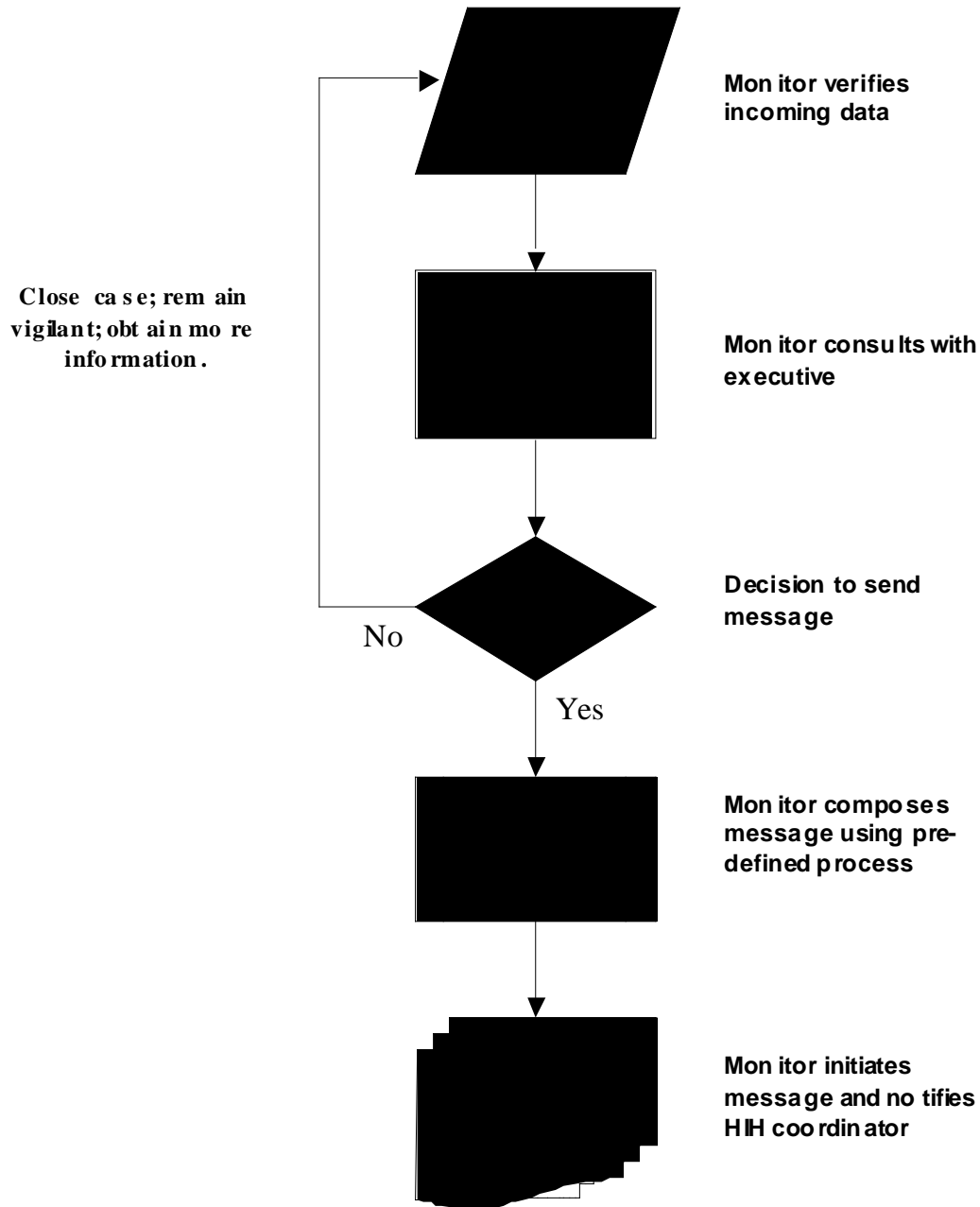

Figure 40 Simplified procedure for issuing warning messages from the HIH

Step 1: Event of interest (EOI)

When a staff member receives information that is potential cause for concern, it is first verified by the staff member and the source, time, and other pertinent details are recorded in the HIH database as an “event of interest” (EOI). See Annex B for guidelines to documenting an EOI.

The HIH database automatically assigns an incident identifier to the entry even if it is eventually decided not to issue an alert message. In this way, all events of interest are assigned unique identifiers for recordkeeping purposes.

In the event an alert is actually issued by the LM-HWS, the incident identifier can be used to collate multiple messages that refer to different aspects of the same incident. For example, if a large earthquake is reported off the coast of Indonesia and the HIH staff member decides it is an event of interest (EOI), then the details are entered into the HIH database and the event is assigned a unique identifier compatible with the CAP <incidents> element.

No other CAP elements are specified until a decision to issue an alert has been made.

If an alert is issued based on the EOI, then the assigned unique identifier serves as a common referent for all subsequent messages based on that event, including messages of varying priorities targeted for different communities, as well as initial alerts and any follow up messages.

The EOI is terminated on a decision by the HIH Executive to “close” the case. When this occurs the unique identifier assigned to the EOI is retired. Subsequent EOI are assigned new unique identifiers compatible with the CAP <incidents> element.

Step 2: Consultation with HIH executive

Having recorded the event of interest (EOI) in the HIH database, the staff member then contacts a member of the HIH executive by telephone.

It is imperative that a current and complete list of telephone numbers of the members of the Executive is maintained and available the HIH for this purpose. The current list of contacts is provided as Annex A to these guidelines. Annex A should undergo regular review and updates to ensure the contact list remains current.

The staff member will provide details of the EOI to the members of the Executive and conduct any follow up inquiry as directed by the Executive.

The members of the Executive will take a decision as to whether to initiate a warning message and any related details pertaining to that message, such as geographic specificity, priority level, special instructions, and so forth.

Step 3: Decision to send message

Having reached a decision, the members of the Executive will provide details to the staff member who will then enter those into the HIH database under the incident identifier established for that EOI:

1. Time that a decision was requested of the Executive.
2. Executive member(s) with whom the EOI was discussed
3. Time that the Executive issued a decision.
4. Details of the decision and/or further instructions from the Executive.

Step 4: Message composition

Having entered the details of the Executive's decision into the HIH database, the staff member will then take immediate action based on the details of the decision.

The following points indicate possible scenarios:

- Decision not to issue a warning and close the case (EOI is terminated).
- Decision not to issue a warning but to remain vigilant (EOI remains open).
- Decision not to issue a warning but to obtain more information and report back to the Executive (EOI remains open).

- Decision to issue a low priority warning and to remain vigilant.
- Decision to issue a medium priority warning, to obtain more information and report back to the Executive.
- Decision to issue a high priority warning and to provide continuous updates to the Executive and/or the HIH Coordinator.

If the staff member has been directed to issue a warning then it is important that they follow the pre-defined process for composing messages in conjunction with any steps defined by the CAP interface application. If the staff member does not have the authority to issue a warning message, then they must contact an "Authorized User" immediately to complete this step.

In cases of extreme urgency, the HIH Coordinator may grant to another staff member temporary authority to issue a warning on their behalf. For example, if there are no Authorized Users on-site at the HIH during a critical moment, a staff member may obtain verbal authorization from the Coordinator to issue a warning (provided that the Executive has been consulted and has approved the warning).

See the following sections on "Training" "Activation" for further details regarding Authorized Users and message composition.

The resulting CAP message will be assigned (either automatically or manually) the same unique incident identifier as the EOI file that spawned the decision to issue a warning.

In the case that there is a discrepancy or any uncertainty on the part with regard to message composition (e.g., details of content) then the Authorized User must contact the HIH Coordinator or HIH Executive immediately for advice before issuing the message.

Step 5: Issuing a Message

Having composed the warning message using the CAP interface application, the Authorized User will issue that message immediately by following the appropriate procedures to ensure it is presented to all designated channels (i.e., telephone, VSAT, ADSR, etc.).

The Authorized User will then immediately contact the HIH Coordinator by telephone to report that a message(s) has been issued.

Any known problems or delays must be reported to the HIH Coordinator immediately.

When a message is issued over the LM-HWS the Authorized User is required to complete a post-activation report. See the following section “Post-Activation” for guidelines concerning this requirement.

Training

It is recommended that an authorization procedure be developed for HIH staff members to qualify them as “Authorized Users” with the authority (and related responsibilities) to compose and issue warning messages over the LM-HWS.

All new LM-HWS personnel should be required to attend a training session provided by the HIH/Sarvodaya. In addition all authorized users should be required to attend regular refresher training to maintain their status. Regular training sessions could be scheduled prior to the cyclone season in November. In addition, authorized users should be required to complete monthly practice sessions composing and initiating messages using the system. To promote compliance, the HIH computers could be designed to log these monthly sessions.

Each initial and refresher training session should include:

- An LM-HWS presentation that explains the importance of the system and how it is intended to operate.
- A detailed description of activation criteria and procedures for the LM-HWS.
- An overview of likely risks and hazards in the communities, histories of disasters, and examples of activation scenarios.
- Training in working with information technology at the HIH.
- Training in interpretation of the data feeds at the HIH.
- Demonstration of LM-HWS activation.

- Hands-on practice in recordkeeping and message composition using both a practice sheet and with the actual software.
- Testing and certification.

Upon completion of the training session, candidates should be asked to sign an “HIH Authorized User” form, which serves as a contract to bind the staff member to the HIH Guidelines. This contract should address a number of matters related to the operational and security dimensions of the HIH:

- Authorized users should agree to be responsible for the security of any passwords or access codes or keys issued to them.
- Authorized users should agree to complete monthly practice sessions on using the system (these could be logged on the HIH computer system).
- Authorized users should agree to attend regular refresher training courses and other professional development as directed by the HIH Coordinator.
- Authorized users should agree to follow established HIH procedures and guidelines for monitoring data feeds and “on call” responsibilities.
- Authorized users should agree to follow established HIH procedures and guidelines for composing warning messages.
- Authorized users should agree to follow established HIH procedures for initiating warning messages.
- Authorized users should agree to disclose all actions taken, communications given and all other forms of information pertinent to the use of the system should they activate it for any reason.

26.4. Monitoring

The HIH maintains data feeds from a number sources. Duty personnel are responsible for ensuring that these sources are active and to immediately report any problems to the HIH Coordinator.

The HIH will be staffed on a 24/7 basis, with the Coordinator and at least one member of the Executive remaining “on call” at all times.

An active set of data feeds will be maintained at the HIH to identify potential events of interest across a range of hazards. The LM-HWS is intended as an “all-hazards” system and the following list provides a range of events that should be included among the data feeds:

- Hazard
- Tsunami
- Cyclone
- Volcano (ash fall)
- Flooding
- Landslide
- Dam break
- Coastal/marine events
- Fire

- Industrial/radiological
- Civil disturbances

In addition to its data feeds, the HIH is to maintain a current list of contact information of secondary sources that might be helpful to confirm or otherwise obtain further details on any Events of Interest. The HIH Coordinator is responsible for the upkeep of this list and it should be reviewed regularly.

The current list of secondary source contacts is found in Annex C.

The HIH should also maintain one or more incoming telephone lines (“hotlines”) to receive reports from outside agencies or organizations (including local communities that might have observed a hazard event). This number should not be public but instead be made available to those agencies and community groups that are likely to be able to provide advance notice of a hazard event (e.g., Pacific Tsunami Warning Centre, local first responders).

The current hotline telephone number is listed in Annex D.

Duty Procedures

The HIH should develop a checklist and procedures for duty personnel who are responsible for monitoring the data feeds. This list should include the following items:

- Ensure all communications equipment (incoming/outgoing) is in good working order.
- Establish a procedure for conducting a regular “sweep” of all primary data sources” (perhaps 2-3 times per hour).
- Identify any recordkeeping requirements (equipment out of order, report on data feeds, etc.)
- Establish a procedure for temporary replacement/substitution of duty personnel (e.g., sick days).
- Establish a procedure for off-site monitoring of data feeds (if applicable).
- Establish a procedure for hand-off of duties during shift change.

Off-duty personnel

Off-duty personnel may be called in to provide support at the HIH in the event a warning message has been issued and a hazard impact is expected. This decision will be at the discretion of the HIH Coordinator.

26.5. Activation

Message Priority

When reporting an event of interest (EOI) an authorized user may request the HIH Executive to issue an **Urgent Priority** warning message when one or more of the following threat conditions are present:

- The life or safety of groups, communities or villages is at immediate risk.
- The danger to the community is impending and widespread.
- The potential impact to the community is catastrophic.
Local first responders needs to be informed of critical, life saving information and be advised to activate their local response plans.

The following table contains recommended CAP values for <urgency>, <severity>, and <certainty> elements in an urgent priority message.

Table 16 CAP values for an urgent priority message

CAP <info> element	Value (recommended)	Interpretation
Urgency	“Immediate” or “Expected”	Immediate responsive action should be taken
Severity	“Extreme” or “severe”	Hazard presents an extraordinary threat to life or property
Certainty	“Observed” or “likely”	The hazard event has occurred or is ongoing (or, > 50%).

Alternately, an authorized user may request the HIH Executive to issue a **High Priority** warning message when one or more of the following threat conditions are present:

- The life or safety of communities or villages is possibly at risk.
- Neighboring communities or villages have been issued an urgent priority warning.
- Residents of the community may see/hear/smell (detect) signs of the hazard and may perceive a danger or health risk.
- Local first responders need to be informed of the hazard situation to provide information to community members.
- Local first responders must be advised to standby to activate their local response plans.

The following table contains recommended CAP values for <urgency>, <severity>, and <certainty> elements in a high priority message.

Table 17 CAP values for a high priority message

CAP <info> element	Value (recommended)	Interpretation
Urgency	“Expected” or “Future” or “Unknown”	Responsive action might need to be taken in near future.
Severity	“Severe” or “Moderate” or “Unknown”	Hazard presents a significant threat to life or property.
Certainty	“Observed” or “Likely”	The hazard event has occurred or is ongoing (or, > 50%).

An authorized user may request the HIH Executive to issue a **Low Priority** warning message when one or more of the following conditions are present:

- The life or safety of a community might be at risk due to a developing hazard.
- A neighboring community has been issued a high priority warning.
- Residents of the community may see/hear/smell (detect) signs of a hazard or nearby response effort and may be curious.
- Local first responders need to be informed of the hazard situation to provide information to community members.
- Local first responders must be advised to standby for further information.

The following table contains recommended CAP values for <urgency>, <severity>, and <certainty> elements in a low priority message.

Table 18 CAP values for a low priority message

CAP <info> element	Value (recommended)	Interpretation
Urgency	“Future” or “Unknown”	Responsive action might need to be taken in near future.
Severity	“Moderate” or “Minor”	Hazard presents a minimal threat to life or property.
Certainty	“Possible” or “Unknown”	The hazard event is possible but not likely ($p < 50\%$).

Message composition

To minimize error and to maintain consistency, authorized users are to compose warning messages using the standard format and procedure established at the HIH.

All messages issued over the LM-HWS will be compliant with Common Alerting Protocol (CAP version 1.1), as specified in the OASIS Open Source Standards document.¹²

¹² <http://www.oasis-open.org/committees/download.php/14759/emergency-CAPv1.1.pdf>

CAP standard specifies that alert messages are composed of an <alert> segment with may contain one or more <info> segments, each of which may contain one or more <area> segments.

Warnings issued by the LM-HWS will be multilingual (Tamil, Sinhalese, and English) and may contain multiple area segments.

The following diagram shows a recommended structure for CAP-compliant multilingual messages to be issued by the LM-HWS. Each <alert> will include three <info> segments providing identical information in Tamil (ta), Sinhalese (si) and English (en). Each of the three info segments will contain identical <resource> and <area> segments, translated if necessary.

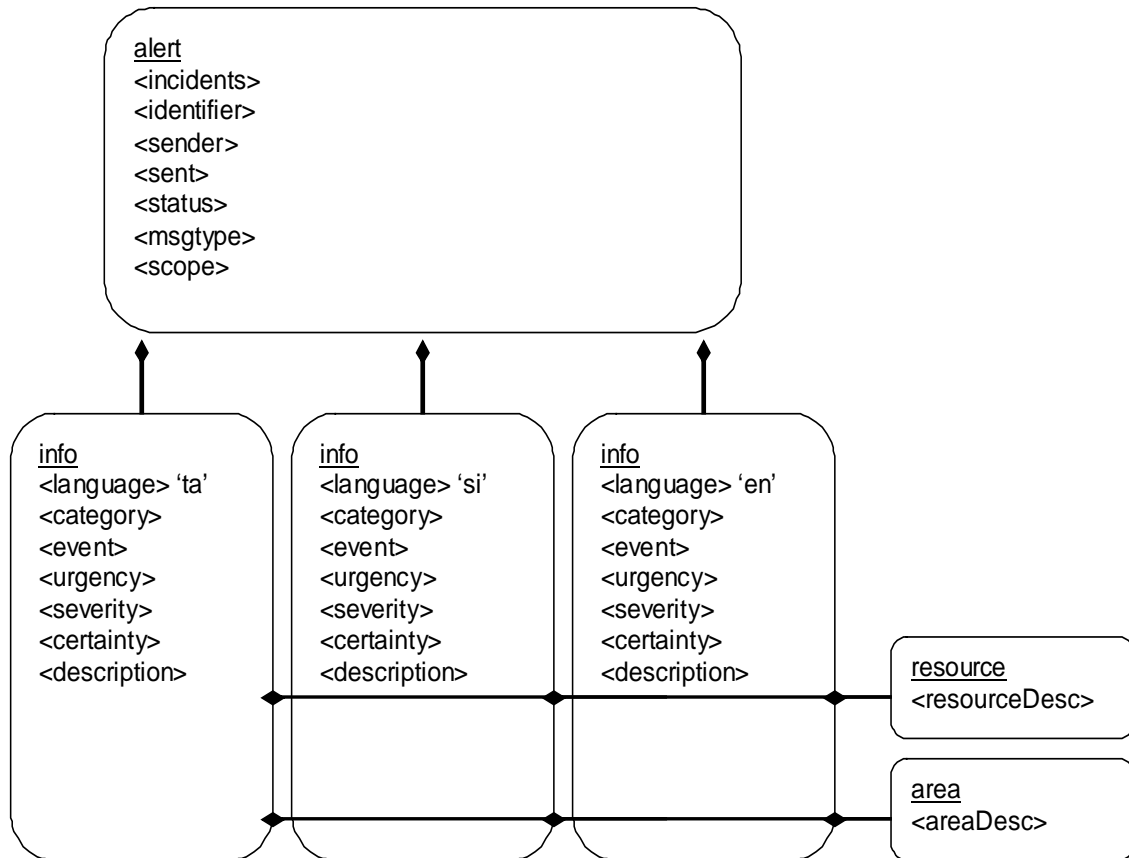

Figure 41 CAP message structure for LM-HWS

To ensure CAP compliance, all messages should be composed using the CAP interface tool, with the required elements specified in the following tables.

Table 19 CAP <alert> sub-elements

<Alert> sub-element	Description	Implementation remarks
<incidents>	Unique identifier of the EOI	This is assigned prior to decision to issue warning and is a common referent for all messages issued with respect to the same EOI.
<identifier>	A unique identifier of the message.	Each message has a unique identifier, but different messages can refer to the same <incidents> reference. Automatically assigned by the CAP software
<sender>	Identifies the originator of this message.	Should specify HIH as organization and the Authorized User that issued the message. Assigned automatically based on the log-in ID of the Authorized User.
<sent>	Date and time the message was transmitted.	Automatically assigned by the CAP software at the moment the message is transmitted.
<status>	Code that denotes appropriate handling of the message.	See the section on “Message Status” for further details.
<msgType>	Code that denotes the nature of the message	See the section on “Message Type” for further details.
<scope>	Code that denotes the intended distribution of the message.	See the section on “Message Scope” for further details.

Table 20 CAP <info> sub-elements

<Info> sub-element	Description	Implementation remarks
<language>	Code that denotes the language of the info sub-element of the message	Two digit ISO 639-2 codes are used to specify language of the message: ta/si/en
<category>	Code that denotes the category of the event referred to by the message.	See the section on “Message Category” for further details.
<event>	Text that denotes the type of event.	See the section on “Message Event” for further details.
<urgency>	Code that denotes the time to impact of the event.	See the section “Message Priority” for further details.
<severity>	Codes that denotes the scale of impact of the event.	See the section “Message Priority” for further details.
<certainty>	Code that denotes the probability of the event.	See the section “Message Priority” for further details.
<description>	Text to describe the subject of the event.	To be used primarily for relaying complete text of government warnings within a CAP message. Event element should be “Government warning.”

Table 21 CAP <resource> sub-element

<Resource> sub-element	Description	Implementation remarks
<resourceDesc>	Text that describes the type and content of a resource attached to the message such as an audio or image file.	See the section “Message Attachments” for further details.

Table 22 CAP <area> sub-element

<Area> sub-element	Description	Implementation remarks
<areaDesc>	Text that describes the affected area of the alert message.	See the section “Area Description” for further details.

Message Status

CAP has a required sub-element <status> to specify the appropriate handling of an alert message. The CAP standard specifies several values for this sub-element, and the following table describes the recommended implementation for the LM-HWS.

Table 23 CAP message <status> values

Value	Implementation remarks
“Actual”	To be used when the message refers to a real event and when all recipients are to take action.
“Exercise”	To be used when the message is transmitted as part of a scheduled or unscheduled exercise. An exercise identifier could be added to the optional <note> sub-element in the CAP message.
“System”	Not to be used for LM-HWS.
“Test”	To be used when testing internal technical parameters of the system. Recipients are to disregard the message. Messages that specify “test” in the <status> element should <u>not</u> be relayed to local first responders. Software filters should be designed to recognize these messages as such and to prevent them from being relayed to local first responders.
“Draft”	Refers to templates that can be stored on a HIH database to expedite message composition. Software filters at the HIH should be designed to prevent the transmission of messages that specify “Draft” in the <status> element.

Message Type

CAP has a required sub-element <msgType> to specify the nature of an alert message. The CAP standard specifies several values for this sub-element, and the following table describes the recommended implementation for the LM-HWS.

Table 24 CAP message <type> values

Value	Implementation remarks
“Alert”	To be used for initial information only.
“Update”	To be used to indicate new information. The message content of an update supersedes that of earlier messages.
“Cancel”	To be used to cancel earlier messages.
“Ack”	Not to be used for LM-HWS.
“Error”	Not to be used for LM-HWS.

Updates and cancellations can specify earlier messages identified in <references> if this optional sub-element is implemented in the system.

The sub-element <references> provides a place for an extended message identifier (in the form *sender, identifier, sent*) to specify earlier messages that might be issued with respect to an EOI.

For example, if a tsunami event were to trigger a low priority message for one region and a high priority message for another region, the <references> sub-element can refer to the extended identifier to ensure the specificity of updates and cancellations.

Message Scope

CAP has a required sub-element <scope> to denote the distribution of an alert message. The CAP standard specifies several values for this sub-element but because the LM-HWS is a closed network only the “Restricted” value should be implemented.

Table 25 CAP message <scope> values

Value	Implementation remarks
“Public”	Not to be used.
“Restricted”	To be used to specify a closed user group of recipients. Designated local first responders represent this closed user group.
“Private”	Not to be used.

In future, if the LM-HWS becomes integrated with larger systems, the optional <restriction> sub-element can provide addressability to distinguish between different user groups within the network.

Message Category

CAP has a required sub-element <category> to denote the category of the subject event of an alert message. The CAP standard specifies several values for this sub-element, and the following table describes the recommended implementation for the LM-HWS.

Table 26 CAP message <category> values

Value	Implementation remarks
“Geo”	To be used for geophysical hazard events, such as earthquakes, tsunamis, landslides.
“Met”	To be used for weather hazard events, such as cyclones, flash floods, lightning.
“Safety”	To be used for general emergency and public safety.
“Security”	To be used for civil disturbances.
“Rescue”	Not to be used.
“Fire”	To be used for fire hazard events.
“Health”	To be used for medical or health hazard events (e.g., disease outbreak, water contamination).
“Env”	To be used for pollution or other environmental hazard events (e.g., air quality).
“Transport”	Not to be used.
“Infra”	To be used for infrastructure hazard events (e.g., dam failure).
“CBRNE”	Not to be used.
“Other”	To be used for other events.

The CAP standard specifies that multiple instances may occur within a single <info> block, which means that several values may be used to classify an event.

It is not clear at this point in time as to how important this sub-element will be for the LM-HWS or for information management at the HII. However, it is strongly recommended that a value for the sub-element be included in all messages sent from the HII because it is required in the CAP standard.

Message Event

CAP has a required sub-element <event> to denote the subject event of an alert message. The CAP standard does not specify values for this sub-element but the following list provides basic terminology for naming events and suggested <category> for each, including a special event for government warnings.

Table 27 CAP message <event> values

Event	Category
Boil water warning	Health
Child abduction	Other
Civil danger	Security

Coastal flood	Met
Contagious disease outbreak	Health
Dam break	Infra
Cyclone	Met
Earthquake	Geo
Flash flood	Met
Flood	Met
Food contamination warning	Health
Government warning	Other
Hazardous materials warning	Env
High wind	Met
Landslide	Geo
Missing person	Other
Power outage	Infra
Problem animal	Other
Special weather statement	Met
Severe thunderstorm	Met
Tornado	Met
Tropical storm	Met
Tsunami	Geo
Volcano	Geo
Wildfire	Fire

This list is not intended to be exhaustive. For the sake of consistency and clarity, the HIH should ensure a reasonable degree of standardization for naming of events.

The event “Government warning” should be used when relaying messages from the government of Sri Lanka, with the full text of the warning included in the <description> element of the CAP message.

Message Attachments (Resource)

CAP has a required sub-element <resourceDesc> to refer to additional file(s) with supplemental information related to the <info> element, such as an audio or image file. Multiple occurrences are permitted in CAP (version 1.1).

Messages composed at the HIH will include audio files recorded in Tamil, Sinhalese and English. Audio files will be used principally for the satellite radio component of the network but could be used for telephone or other devices if necessary.

Either of two methods for creating the audio files can be employed:

- A staff member at the HIH composes three audio versions of the message (Tamil, Sinhalese, and English) and then reads them into a voice-recording device and saving them as one or more digital files.

- An application automatically converts the CAP message into three audio versions (English, Sinhalese, Tamil) using text-to-voice software, saving them as one or more digital files.

Audio messages will include certain elements set out in the CAP message, effectively matching the text version of any warning message issued by the HIH. Certain CAP sub-elements may not be relevant for audio versions.

How the CAP elements will be scripted may vary depending on which method is used to record the audio files. The following is one example of a script for an urgent priority tsunami warning that is integrated with some of the CAP required elements.

It is important to note that some of these elements may not translate easily using text-to-voice software and may need some additional treatment for the audio version (e.g., date and time in the <sent> element).

Message header:

Your attention please! This is an activation of the Sarvodaya Hazard Warning System. The following emergency <msgType>alert</msgType> may affect your village. This is an <status>actual</status>event. Listen carefully and prepare to take appropriate action based on your village's response plan.

Message content:

At <sent>0800hrs local time on July 1, 2006</sent> the <sender>Sarvodaya Disaster Management Centre</sender> has been informed of a large magnitude earthquake off the coast of Indonesia. This event is <certainty>likely</certainty> to produce a <event>tsunami</event> and presents an <urgency>immediate</urgency> and <severity>extreme</severity> risk for the <areaDesc>village of Gurathwa and the Galle District</areaDesc>.

To repeat: an <urgency>immediate</urgency> <event>tsunami</event> <msgType>alert</msgType> has been issued for the <areaDesc>village of Gurathwa and the Galle District</areaDesc>.

Message trailer:

This message was issued by the Sarvodaya Hazard Warning System. If your area is affected, it is important that you take appropriate action based on your local response plan. Listen to local radio or television for further updates.

Figure 42 Sample script based on CAP elements

Further discussion will need to take place before message scripting, formatting of the audio files, and transport options for the <resource> element can be finalized.

A key concern is whether the resource file is to be included in the CAP message itself <derefUri> or whether it will reside on a server for subsequent retrieval <uri>. See CAP standard, section 3.2.3 <uri> and <derefUri> sub-elements.

Area Description

To the fullest extent possible, messages issued by the HIH should clearly specify the area of impact and CAP has a required sub-element <areaDesc> for this purpose.

For the purpose of the first phase of the LM-HWS this sub-element will be defined according to the selected districts and villages participating in the pilot study.

Geographical specificity is particularly important when multiple areas may have differing levels of priority. Therefore multiple messages should be issued by the HIH when it is determined that the event could have a range of severity values. For example, villages in the direct path of a hazard event may receive urgent priority messages, while neighboring communities are issued high or low priority messages.

The table on the following page specifies Districts and Villages to be used in specifying the <areaDesc> sub-element for the first phase of the LM-HWS.

Messages may be directed to an entire district (e.g., “Ampara District”) or to a specific village within a district (e.g., “Ampara, Panama North”).

Further geocoding of CAP messages is possible with the <polygon> <circle> and <geocode> sub-elements. The HIH will need to determine if this method is to be implemented in the LM-HWS.

Table 28 message <areaDesc> values

District	Village
Ampara	[District]
Ampara	Abeyasinghe Pura
Ampara	Panama North
Batticalo	[District]
Batticalo	Nidavur
Batticalo	Palmunnai
Batticalo	Periyakallar
Batticalo	Saturkondagnya
Colombo	[District]
Colombo	Moratuwella
Colombo	Modara
Galle	[District]
Galle	Brahamanawattha
Galle	Indivinna
Galle	Urawatha

Galle	Valhengoda
Galle	Venamulla
Hambantota	[District]
Hambantota	Krinda/Modarapallassa
Hambantota	Modaragama
Hambantota	Samodhagama
Hambantota	Samudragama
Kalmunai	[District]
Kalmunai	Kalmunai II
Kalmunai	Oluville
Kalmunai	Ulla 1
Kalutara	[District]
Kalutara	Diyalagoda
Kalutara	Maggona
Kalutara	Thalpitiya
Jaffna	[District]
Jaffna	Munnai
Jaffna	Thondamanar
Matara	[District]
Matara	Kottegoda
Matara	Meddhawatha
Matara	Mirissa South
Matara	Thallala South
Matara	Wathegama North
Trincomalee	[District]
Trincomalee	Thirukadalar

Message Transmission

Having composed the message, the HIH staff member then issues a warning by transmitting that message over the LM-HWS. Software located at the HIH converts the CAP elements into suitable transport formats and relays them to the appropriate gateways.

In the event of a known failure in transmission, the HIH staff member is to attempt to reach the affected areas by alternate means. A list of alternate telephone numbers should be maintained at the HIH for this purpose.

In some cases, the HIH staff member may need to contact the first responder in a neighboring village and request that the message be relayed between villages by hand or other means.

Repeat Activations

During an incident the danger level to local villages may change over time. If the danger level begins to increase in any of the following circumstances, additional messages should be issued only after the HIIH executive has provided authorization to do so:

- A potential secondary impact to the first event creates new hazards to the affected area or to neighboring villages.
- If new information comes to light that suggests the situation is more certain, severe, or urgent than initially indicated in a previous message.
- If the affected area must be expanded.

All-clear Messages

It is not recommended that the LM-HWS send “all-clear” messages over the system to the local first responders. Instead, local first responders in consultation with Sarvodaya should develop a local procedure for event termination.

Post-Activation

Having successfully issued the message, the authorized user will then immediately contact the HIIH Coordinator to confirm the activation and to request further instructions.

The HIIH Coordinator will in turn contact the HIIH Executive and provide them with a situation report. The HIIH Coordinator will also determine if support staff will be needed to handle follow-up activities.

The Authorized User is required to complete an Activation Report following activation of the LM-HWS. The report is signed by the HIIH Coordinator and submitted to the HIIH Executive. Details of the report should include the following:

- Name of authorized user, position within the HIIH
- Name of person in the HIIH Executive that authorized the activation.
- Time and date of the activation.
- Details of the activation, including all elements specified in the CAP messages issued (copies of the CAP messages should be attached to the report).
- Details of subsequent activations.

26.6. Prohibited Practices

There are situations when it is not appropriate to activate the LM-HWS. The HIH Executive will ultimately decide on when to issue a warning message but a number of principles will generally be followed.

The LM-HWS should not be used for:

- Transmission of messages to the general public.
- The transmission of “all clear” messages.
- General information on disaster related services and response plans. This is to be provided in response plans held and maintained by local first responders.
- Any circumstance when life or safety is not threatened.

A process for guarding against system misuse or abuse should be put in place at the HIH. All cases of accidental activation or misuse must be reported immediately to the HIH Coordinator and to the HIH Executive.

Effective training is the most important safeguard against misuse and abuse in the first instance. However, when dealing with a case of misuse by an authorized user, the HIH Coordinator should consider several options depending on the severity of the case:

- Re-training without probation.
- Re-training with probation.
- Suspension of authorized user status.
- Revocation of authorized user status.

26.7. Testing

The LM-HWS must be tested on a regular basis. The following table presents various testing modes and the CAP <status> values to be used in message composition.

Table 29 CAP status for test categories

Live Test		Silent Test	
Closed simulation with local first responder.	Village-wide simulation with community members involved.	Internal HIH test (no messages transmitted to local first responders).	System interoperability test (no messages transmitted to local first responders).
CAP <status> “Exercise”	CAP <status> “Exercise”	CAP <status> “Test”	CAP <status> “Test”

Live Tests may be scheduled or unscheduled. It is recommended that all village-wide live tests be scheduled.

Testing Schedule

The HIH will need to determine a schedule of Live and Silent tests for the system.

Reporting Procedure

The HIH Coordinator will submit a “head-end” report immediately following any test of the system. This report should include details of the test message, reliability of various elements of the system, problems encountered during the test, other observations.

Local first responders, supported by Sarvodaya, should submit a “reception” report immediately following any Live Test of the system. This report should include details of the test message (time received, message details, etc.), reliability of the reception device, problems encountered during the test, and other observations.

Support partners (e.g., Dialog, WorldSpace) should be encouraged to submit an “interoperability” report following any Silent Test that involves their network. This report should identify any problems encountered during the test or other relevant observations.

It is recommended that the HIH Coordinator compile results of the head-end, reception, and system interoperability reports into a summary report and recommendations for submission to the HIH Executive within one week of any Live or Silent Test.

26.8. Annex A: Contact Information

HIH Executive

HIH Coordinator

Assistant to the Coordinator

HIH Monitors

HIH Support staff

Technical partners and service providers

26.9. Annex B: Guidelines for documenting an EOI

- Incident Identifier: must be compatible with CAP standard for <incident> element
- Staff member ID:
- Date observed: dd/mm/yy
- Time observed: hh:mm (24hr, local time)
- Event description: (see “Event” list if necessary)
- Location of event: (country, region, ocean, etc.)
- Information source: website, telephone call, etc.; include all details of the source
- Estimated time of arrival (urgency): Hours? Minutes?
- Estimated severity: Extreme? Severe? Moderate? Minor? Unknown?
- Has the Sri Lanka government issued a warning for this event? Yes/No/Unknown
- If so, do you have a copy of the complete text of this warning?
- Have any other governments issued a warning for this event? Yes/No/Unknown
- If so, which governments?
- Have you verified the information with a secondary source? Yes/No
- If yes, then indicate the source:
- Time that the Executive was contacted: hh:mm (24hr, local)
- What are the instructions of the Executive?
 - Close the case
 - Remain vigilant
 - Obtain more information
 - Issue an alert
- Details of the Executive’s instructions:
- Time that a decision was taken: hh:mm (24hr, local time)

26.10. Annex C: Secondary sources for confirming Events of Interest

This list must be kept up to date and should be reviewed regularly by the HIH Coordinator.

Table 30 Contact database for confirming events

Last Update:		
Event type	Primary contact (name, organization, telephone)	Alternate contact (name, organization, telephone)
Tsunami		
Cyclone		
Volcano (ash fall)		

Flooding		
Landslide		
Dam break		
Coastal marine events		
Fire		
Industrial/radiological		
Civil disturbances		

26.11. Annex D: Telephone “hotline” number for contacting the HIH

The following number is to be made available to local first responders and other organizations at the discretion of the HIH Coordinator.

The intent of the “hotline” is to provide a telephone link to the HIH for providing advance notice of a hazard event or for other emergency purposes.

HIH hotline: +94 (x)xxx xxx xxx

26.12. Annex F: CAP alert message example

The following is a speculative example of an urgent priority tsunami warning issued using the LM-HWS CAP profile in the form of an XML message.

```
<?xml version = "1.0" encoding = "UTF-8"?>
<alert xmlns = "urn:oasis:names:tc:emergency:cap:1.1">
  <incidents>120321072006</incidents>
  <identifier>HIH0001</identifier>
  <sender>nwaidyanatha@hih.sarvodaya.org</sender>
  <sent>2006-07-21T13:40:01+05:30</sent>
  <status>Actual</status>
  <msgType>Alert</msgType>
  <scope>Restricted</scope>
  <info>
    <language>en</language>
    <category>Geo</category>
    <event>Tsunami</event>
    <urgency>Immediate</urgency>
    <severity>Extreme</severity>
    <certainty>Observed</certainty>
    <description>A large magnitude earthquake off the east coast of Indonesia occurred at 12:00hrs
local time generating a tsunami wave that is expected to reach the coast of Sri Lanka by 13:30hrs local
time. The tsunami wave presents an immediate and extreme hazard to all coastal regions of Sri
Lanka</description>
    <resource>
      <resourceDesc>audio file (mpg)</resourceDesc>
      <uri>http://www.hih.sarvodaya.org/getalertaudio_en</uri>
    </resource>
    <area>
      <areaDesc>All coastal regions of Sri Lanka</areaDesc>
    </area>
  </info>
</alert>
```

27. TECHNICAL ANNEX 16: TRAINING – HAZARDS

Goal (Session I)

To impart an understanding of the concepts of hazards, multiple hazards and disaster and to develop the capability for hazard assessment

Learning Objective

- After completing this session, the participant will be able to perform a hazard identification and assessment for a selected community

Learning Outcomes

Participant will learn to --

- Distinguish between the concepts of hazard, hazard event, secondary hazards, multiple hazards and disaster
- Classify and describe types of hazards
- Explain hazard characteristics such as magnitude, frequency, intensity and rate of onset and their importance
- Conduct hazard identification, hazard assessment and hazard mapping and explain their functional value

27.1. Definition of Hazards

Standards Australia (2000) defines a hazard as - *'A source of potential harm or a situation with a potential to cause loss.'*

Another definition can be - *A natural event that has the potential to cause harm or loss.* A Hazard is a threat. A future source of danger. It has the potential to cause harm to --

People - death, injury, disease and stress

Human activity – economic, educational etc.

Property - property damage, economic loss of

Environment - loss fauna and flora, pollution, loss of amenities.

Some examples of hazards in Sri Lanka are cyclones, floods, landslides, droughts, tsunami and lightning.

27.2. Hazard Events

Environmental events become hazards once they threaten to affect society and/or the environment adversely. A physical event, such as a volcanic eruption, that does not affect human beings is a natural phenomenon but not a natural hazard. A natural phenomenon that occurs in a populated area is a hazardous event.

A hazardous event that causes unacceptably large numbers of fatalities and/or overwhelming property damage is a natural disaster. In areas where there are no human interests, natural phenomena do not constitute hazards nor do they result in disasters.

Magnitude is an important characteristic for analyzing hazards since only occurrences exceeding some defined level of magnitude are considered hazardous.

- The level of harm is governed by
- Magnitude of the hazard
- Frequency of hazard or recurrence
- Intensity at the impact point

27.3. Multiple Hazards

When more than one hazard event impacts the same area, there arises a multiple hazard situation. These different hazard events may occur at the same time or may be spaced out in time. The planning process in development areas does not usually include measures to reduce hazards, and as a consequence, natural disasters cause needless human suffering and economic losses. From the early stages, planners should assess natural hazards as they prepare investment projects and should promote ways of avoiding or mitigating damage caused by hazards. Adequate planning can minimize damage.

27.4. The Return Period

Majority of hazards have return periods on a human time-scale. Examples are five-year flood, fifty-year flood and a hundred year flood. This reflects a statistical measure of how often a hazard event of a given magnitude and intensity will occur. The frequency is measured in terms of a hazard's recurrence interval.

For example, a recurrence interval of 100 years for a flood suggests that in any year, a flood of that magnitude has a 1% chance of occurring.

Such extreme events have very low frequencies but very high magnitudes in terms of destructive capacity. This means that an event considered being a hundred year flood would cause severe damage compared to a five-year flood.

27.5. Classification of Hazards

Are hazards natural?

There are many different ways of classifying hazards. One is to consider the extent to which hazards are natural. Natural hazards such as earthquakes or floods arise from purely natural processes in the environment. Quasi-natural hazards such as smog or desertification arise through the interaction of natural processes and human activities.

Technological (or man-made) hazards such as the toxicity of pesticides to fauna, accidental release of chemicals or radiation from a nuclear plant. These arise directly as a result of human activities.

A typology based on Hewitt and Burton (1971) would appear as follows.

- | | |
|---|--|
| <p>1. <i>Atmospheric</i>
 Single element
 Excess rainfall
 Freezing rain (glaze)
 Hail
 Heavy snowfalls
 High wind speeds
 Extreme temperatures</p> | <p><i>Atmospheric</i>
 Combined elements/events
 Hurricanes
 ‘Glaze’ storms
 Thunderstorms
 Blizzards
 Tornadoes
 Heat/cold stress</p> |
| <p>2. <i>Hydrologic</i>
 Floods – river and coastal
 Wave action
 Drought
 Rapid glacier advance</p> | <p>3. <i>Geologic</i>
 Mass-movement
 Landslides
 Mudslides
 Avalanches
 Earthquake
 Volcanic eruption
 Rapid sediment movement</p> |
| <p>4. <i>Biologic</i>
 Epidemic in humans
 Epidemic in plants
 Epidemic in animals
 Locusts</p> | <p>5. <i>Technologic</i>
 Transport accidents
 Industrial explosions and fires
 Accidental release of toxic chemicals
 Nuclear accidents
 Collapse of public buildings</p> |

Natural hazards and human intervention

Although humans can do little or nothing to change the incidence or intensity of most natural phenomena, they have an important role to play in ensuring that natural events are not converted into disasters by their own actions. It is important to understand that Human intervention can increase the frequency and severity of natural hazards.

For example, when the toe of a landslide is removed to make room for a settlement, the earth can move again and bury the settlement.

Human intervention may also cause natural hazards where none existed before. Volcanoes erupt periodically, but it is not until the rich soils formed on their eject are occupied by farms and human settlements that they are considered hazardous.

Human intervention reduces the mitigating effect of natural ecosystems. Destruction of coral reefs, which removes the shore's first line of defense against ocean currents and storm surges, is a clear example of an intervention that diminishes the ability of an ecosystem to protect itself. An extreme case of destructive human intervention into an ecosystem is desertification, which, by its very definition, is a human-induced "natural" hazard. Quasi-natural and na-tech are terms used to denote such hybrids.

If human activities can cause or aggravate the destructive effects of natural phenomena, they can also eliminate or reduce them.

Controllable events vs. immutable events

For some types of hazards the actual dimensions of the occurrence may be altered if appropriate measures are taken. For others, no known technology can effectively alter the occurrence itself. For example, construction of levees on both sides of a stream can reduce the extent of inundations, but nothing can moderate the ground shaking produced by an earthquake.

27.6. More Hazard Terminology

Secondary hazards

These are hazards that follow as a result of other hazard events. Hazards secondary to an earthquake may be listed as follows to illustrate the concept. Primary hazard is the earthquake. Secondary hazards are

- Building collapse
- Dam failure
- Fire
- Hazardous material spill
- Interruption of power/ water supply/ communication/ transportation/ waste disposal
- Landslide
- Soil liquefaction
- Tsunami (tidal wave)
- Water pollution

Rate of onset

Include rapid-onset and slower-acting (slow onset) natural hazards.

The speed of onset of a hazard is an important variable since it conditions warning time. At one extreme, earthquake, landslides, and flash floods give virtually no warning. Less extreme are tsunamis, which typically have warning periods of minutes or hours, and hurricanes and floods, where the likelihood of occurrence is known for several hours or days in advance. Volcanoes can erupt suddenly and surprisingly, but usually give indications of an eruption weeks or months in advance. (Colombia's Volcán Ruiz gave warnings for more than a year before its destructive eruption in 1985.)

Other hazards such as drought, desertification, and subsidence act slowly over a period of months or years. Hazards such as erosion/sedimentation have varying lead times: damage may occur suddenly as the result of a storm or may develop over many years.

27.7. Hazard Identification and Assessment

If you are living in an area exposed to multiple hazards, for each hazard, ask yourself the following questions and try to answer them. The answers are usually based on past experience of hazard events. They may be recorded or may be gathered through interviews. They could give you a reasonable indication of the threat posed by the hazard for the area you live in.

- Could this hazard affect the area you live in?
- Is this hazard a significant threat there?
- How often does it pose a threat? E.g. Once every 5 years? 10 years?
- What is a close estimate of the population size that could be affected by this hazard event? Give a rating. Very high? High? Medium? Low?
- What is the expected duration of the hazard?
- What is the expected damage from the hazard event? Give a rating. Very high? High? Medium? Low?
- What is the expected intensity of impact expected? Give a rating.
- Very high? High? Medium? Low?
- How predictable is the threat?
- Can the effect of the event be reduced?

Hazard Assessment is sometimes called Hazard Evaluation or Hazard Analysis (UNDRO, 1991). There seems to be a lack of consistency in the use of this terminology.

Hazard Assessment is the process of estimating, for defined areas, the probabilities of the occurrence of potentially-damaging phenomenon of given magnitude within a specified period of time.
UNDRO

Governments mostly carry out hazard reduction measures without much enthusiasm and within economic constraints. In order to compete for limited expenditure and resources hazard reduction proposals must find justification. This is facilitated by the collection of information about

- Local hazards - Location & Probability
- The extent to which they threaten local populations - Severity
- Ease with which their effects can be averted - Manageability

The severity of a natural hazard is quantified in terms of the magnitude of occurrence, which is an event parameter. It can also be done in terms of the effect of the occurrence at a particular location. This is called a site parameter. Both parameters may be combined in certain situations. Parameters for selected hazards are listed below.

Table 31 Event and site parameters of selected Hazards

Natural Hazard	Event Parameter	Site Parameter
Cyclone	Wind speed - km/h	Area affected
Earthquake	Magnitude – Richter Scale	Intensity –Modified Mercalli Scale
Flood	Area flooded – km ² Volume of water – m ³ Speed	Depth of flood water - meters
Landslide	Volume of material dislodged, Area affected	Ground displacement - meters
Tsunami	Height of wave crest	Depth of flood water
Volcano	Eruption size and duration	Ash fall – meterLava flow - area

Hazard assessment approaches

The process of collecting this information is called hazard assessment.

These studies rely heavily on

- Available scientific information, including geologic, geomorphic, and soil maps; climate and hydrological data; and topographic maps, aerial photographs, and satellite imagery.
- Historical information, both written reports and oral accounts from long-term residents. These may include myths and legends.

For assessment of most natural phenomenon, one cannot expect complete data required to carry out a comprehensive assessment. Depending on the situation, various methods are used with obvious variations in the degree of accuracy.

Quantitative approach

Here mathematical functions are used to denote relationships between variable considered to quantify the hazard. Numerical data can be fed in to assess the impact of the hazard event. An example is the probable flood that a particular rainfall could cause within a watershed area. Flood dimensions such as depth of flood and area of inundation would depend on the volume of water that flows into the stream. Surface run-off, soil permeability, vegetation cover etc would determine this. The empirical data collected from historical records as well as theoretical data from basic principles of physics are used to derive the relationship between variables. The mathematical expression so derived could be used to

forecast future events. However, quantitative assessment may not be possible for all hazard events.

Qualitative approach

This method uses ranking such as 'high', 'moderate' and 'low' to assess a hazard event. Where there is a lack of sufficient data for quantitative evaluation, or where certain variables cannot be expressed numerically, this qualitative ranking may be appropriate to take hazard mitigation decisions.

Probabilistic approach

After identifying the hazards that affect the planning area and assessment of the impacts from those hazards, a probability analysis is undertaken. It provides an estimate of the probability of each hazard affecting an area or region.

Probability for each hazard may be categorized as 'high', 'moderate' or 'low'.

Probability of occurrence can be calculated through research on past events.

The Outcome

The outcome is natural hazards information, which denotes the presence and effect of natural phenomena. Hazard assessment is the first step for hazard mitigation planning. It prioritizes hazards so that a community or a government may use discretion to plan and implement hazard mitigation action. This information should ideally include the location, severity, frequency, and probability of occurrence of a hazardous event. Location is the easiest for planners to find; the rest can often be obtained from sectoral agencies, natural hazard research and monitoring centers and integrated development planning studies.

It could have information on natural ecosystems (e.g., slopes and slope stability, river flow capacity, vegetation cover), which provides the basis for estimating the effect natural hazards can have on these systems. Change in the ecosystem may create, modify, accelerate, and/or retard the occurrence of a natural event.

Large-scale data describing lifeline infrastructure and human settlements for example, are critical elements for preparing vulnerability assessments and for initiating disaster preparedness and response activities.

Hazard Mapping

This is the process of establishing geographically where and to what extent particular phenomenon is likely to pose a threat to people, property, infrastructure and economic activities. -UNDRO

Probability of hazard occurrence varies from place to place. The use of mapping to synthesize data on natural hazards and to combine these with socioeconomic data facilitates analysis. It improves communications among participants in the hazard management process and between planners and decision-makers. Two important techniques in use are

- Multiple hazard mapping and
- Critical facilities mapping

Multiple Hazard Mapping (MHM)

This is usually carried out with new development in mind. Valuable information on individual natural hazards in a study area may appear on maps with varying scales, coverage, and detail, but these maps are difficult to use in risk analyses due to the inability to conveniently overlay them on each other for study. Information from several of them can be combined in a single map to give a composite picture of the magnitude, frequency, and area of effect of all the natural hazards.

- Regional scale hazard mapping uses 1:100,000 to 1:250,000. These are useful during planning stages of regional development.
- Urban land use planners may need medium scale hazard maps of 1: 10,000 to 1:25,000.
- Site investigation for infrastructure projects may require large-scale hazard maps of 1:1,000 to 1:5,000.
- The multiple hazard map (MHM; also called a composite, synthesis, or overlay map) is an excellent tool for fomenting an awareness of natural hazards and for analyzing vulnerability and risk, especially when combined with the mapping of critical facilities. Its benefits include the following:
 - Characteristics of the natural phenomena and their possible impacts can be synthesized from different sources and placed on a single map.
 - It can call attention to hazards that may trigger others (as earthquakes or volcanic eruptions trigger landslides) or exacerbate their effects.
 - A more precise view of the effects of natural phenomena on a particular area can be obtained. Common mitigation techniques can be recommended for the same portion of the study area.
 - Sub-areas requiring more information, additional assessments, or specific hazard-reduction techniques can be identified.
 - Land-use decisions can be based on all hazard considerations simultaneously.

The use of a multiple hazard map also has several implications in emergency preparedness planning:

- It provides a more equitable basis for allocating disaster-planning funds.
- It stimulates the use of more efficient, integrated emergency preparedness response and recovery procedures.
- It promotes the creation of cooperative agreements to involve all relevant agencies and interested groups.

The base map upon which to place all the information is the first consideration. It is usually selected during the preliminary mission. If at all possible, it is best to use an existing map or controlled photograph rather than go through the difficult and time-consuming process of creating a base map from scratch.

The scale used for an MHM depends on the hazard information to be shown, availability of funds and the scale of the base map. If a choice of scales is available, then the following factors should be considered:

- Number of hazards to be shown.
- Hazard elements to be shown
- Range of relative severity of hazards to be shown.
- Area to be covered.
- Proposed uses of the map.

Much hazard information will be in forms other than maps, and not readily understandable by laymen. It must be "translated" for planners and decision-makers and placed on maps. The information should explain how a hazard may adversely affect life, property, or socioeconomic activities, and must therefore include location, likelihood of occurrence (return period), and severity. If some of this information is missing, the planning team must decide whether it is feasible to fill the gaps.

Development and investment decisions made in the absence of these data should be noted. Despite the importance of multiple hazard maps in the integrated development planning process, planners and decision-makers must remember that the credibility, accuracy, and content of an MHM are no better than the individual hazard information from which it was compiled. Furthermore, since it contains no new information - it is merely a clearer presentation of information previously compiled - the clarity and simplicity of the map is the key to its utility.

Critical Facilities Mapping (CFM)

This is carried out for development within existing infrastructure in mind. The term "critical facilities" means all man-made structures or other improvements whose function, size, service area, or uniqueness gives them the potential to cause serious bodily harm, extensive property damage, or disruption of vital socioeconomic activities if they are destroyed or damaged or if their services are repeatedly interrupted.

The primary purpose of a critical facilities map (CFM) is to convey clearly and accurately to planners and decision-makers the location, capacity, and service area of critical facilities. An extensive number of such facilities can be presented at the same time. Also, when combined with a multiple hazard map, a CFM can show which areas require more information, which ones require different hazard reduction techniques, and which need immediate attention when a hazardous event occurs. Some of the benefits of a CFM are:

- The uniqueness of service of facilities in the area (or lack of it) is made clear.
- Facilities that may require upgrading and expansion are identified.
- The impact of potential development on existing infrastructure can be assessed before a project is implemented.
- Any need for more (or better) hazard assessment becomes apparent

Combining critical facilities maps and multiple hazard maps

There are many advantages in combining a CFM, with a MHM, and integrating both into the development planning process. For example, if a critical facility is found to be in a hazardous area, planners and decision-makers are alerted to the fact that in the future it may confront serious problems. Its equipment, use and condition can then be analyzed to evaluate its vulnerability.

If appropriate techniques to reduce any vulnerability are incorporated into each stage of the planning process, social and economic disasters can be avoided or substantially lessened. Avoiding hazardous areas, designing for resistance, or operating with minimal exposure, can make new critical facilities less vulnerable.

Mitigation strategies for existing critical facilities include relocation, strengthening, retrofitting, adding redundancy, revising operations, and adopting emergency preparedness, response, and recovery programs.

The benefits obtained by combining a CFM and an MHM include:

- Project planners and decision-makers are made aware of hazards to existing and proposed critical facilities prior to project implementation.
- The extent to which new development can be affected by the failure or disruption of existing critical facilities as a consequence of a natural event can be determined.
- More realistic benefit-cost ratios for new development are possible.
- Sub-areas requiring different assessments, emergency preparedness, immediate recovery, or specific vulnerability reduction techniques can be identified.

Mapping techniques and tools

Community knowledge: - A simple mapping of local experience can be achieved using local knowledge. Tools used in rural development activities such as

Participatory Rural Appraisal (PRA): can be very useful in this work. The method is cost effective and the outcome reflects the local perception of hazard. The information can overlay local contour maps.

Surveys on historic events: There may be reports compiled on historic events, which may focus on varying issues depending on its original purpose. However they may contain useful information.

Scientific investigation and research: Usually carried out through teamwork with experts from an array of different disciplines. For example, landslide hazard mapping would require skills of geologists, geo-technical engineers, geomorphologists, topography and so on.

Data over large areas for extensive time periods are collected. These are multidisciplinary studies and each discipline would provide tools and techniques, which become more sophisticated and more accurate over time.

Computer modeling using such data has opened up new vistas for hazard prediction. Geographic Information Systems (GIS) modeling is one outstanding example. Remote sensing by satellite (RS) refers to the viewing of the earth's surface using sensing devices fixed onto satellites in orbit. Such data have already proved useful in flood prediction in Bangladesh for example. The future holds promising prospects for this area of study.

28. TECHNICAL ANNEX 17: TRAINING – VULNERABILITY AND RISK

Goal (Session 2)

To instill an understanding of the concepts of vulnerability and risk and to develop the capability for risk assessment.

Learning Objective

- The participant will be able to perform a vulnerability and risk assessment for a selected community

Learning Outcomes

- The participant will learn to
- Distinguish between the concepts of vulnerability and risk
- List and describe criteria that add to the vulnerability of a community
- List and describe criteria that reduce the vulnerability
- Name and explain the components in quantification of risk
- Give a breakdown of elements at risk

28.1. Vulnerability

Vulnerability definition

A set of prevailing and consequential conditions – physical, social, and attitudinal – which adversely affect the community's ability to prevent, mitigate, prepare and respond to the impact of a hazard event. The predisposition to suffer damage due to external events.

This definition is more focused on communities - Vulnerability is a condition or a predisposition. It applies to individuals, groups of individuals or communities, but it can be also used when referring to physical structures or the environment in general. Vulnerability is about Susceptibility and Resilience under threat of a hazard event.

Susceptibility: **Proximity** and **exposure** to an event. It is the potential to incur harm or avoid loss. It is the fact of being exposed. You can be susceptible but not vulnerable. E.g. a landslide is threatening a

house but the owners have built a wall to protect it and to divert the landslide. Susceptibility is easy to assess.

Resilience: Access to resources and capacities which determine the ability to recover from the impacts of to a hazard event It is the ability to adjust and recover. E.g. the owners of the house threatened by a landslide have a second house in town. They reside there during the rainy season. One can be susceptible, but if he/she is resilient, one is not vulnerable. Resilience has many components: It implies access to resources, individual skills, beliefs, etc. Compared to susceptibility, it is more difficult to assess. E.g. Most Middle Eastern countries are in deserts. But their water supply system helps them not to be exposed to drought conditions in normal life.

If susceptibility is very low and resilience very high, then one has minimum vulnerability. E.g. take a displaced population in an emergency settlement. Susceptibility to measles is very high. If all children are immunized however, resilience is high, and the vulnerability would be low. When Susceptibility is high and resilience very low, one has maximum vulnerability. If the children are not immunized, resilience is very low and the vulnerability is high. (Source: the Australian Emergency Management Society).

Exposure

It is the state of being physically affected from a hazard. Researchers differentiate between voluntary and involuntary exposure to hazards. Examples of involuntary exposure include air pollution (as we must breathe ambient air), toxic contamination of food (as we must eat), and water pollution (as we have to drink). We do, on the other hand, have a greater choice over where we live and what activities we engage in (living in coastal or seismically active zones is to some extent voluntary; smoking and exposing yourself to the threat of cancer is definitely voluntary).

Capacity

Those positive conditions or recourses which increase the ability of a community to deal with hazards.

Capacity may be

- Physical
- Social/Organizational
- Attitudinal/Motivational.

Capacity is also reflected in the preparedness of the community to face a hazard event.

Preparedness

Measures taken in anticipation of a disaster to ensure that appropriate and effective actions are taken in the aftermath of a hazard event. To enhance preparedness, people plan how to respond in case a hazard event occurs and work to increase the resources available to respond effectively. Preparedness activities are designed to help save lives and minimize damage by preparing people to respond

appropriately.

Response

Refer to actions taken immediately following the impact of a hazard event when exceptional measures are required to meet the basic needs of the survivors. –ADPC. It refers to the sum of all actions taken to adjust to hazards; more narrowly defined to mean the appropriate actions taken during an emergency to protect people and the things they value from harm, rescue them, and facilitate the transition to post-disaster recovery.

Socio-economic indicators

Socio-economic indicators provide another dimension to view Vulnerability. The Indicator of Human Development (IDH) is synthesized by combining other indicators and gathers together

- The adjusted GDP per capita
- Life expectancy
- Adult literacy.

The assumption is that the lower the IDH, the lower will be the mean wealth, the literacy and the average health state of the population. This will increase the vulnerability to physical hazards. Poverty is one of the major vulnerability criteria. Poverty also has an effect on housing which constitute a usually high damage percentage in case of disaster (Center for Research on the Epidemiology of Disasters, CRED).

Demographic indicators

When high to very high population densities (>200 hab/km²) are combined with unfavorable socio-economic parameters (low IDH, high birth and mortality rates), the vulnerability is expected to be high (CRED).

28.2. Risk

Risk definition

Risk is the likelihood or probability of a hazard event of a certain magnitude occurring. Risks are measures of the threat of hazards. Risk is the actual exposure of something of human value to a hazard. Often regarded as the product of probability and loss. Risk is the exposure or the chance of loss due to a particular hazard for a given area and reference period. It may be expressed mathematically as the probability that a hazard impact will occur multiplied by the consequences of that impact.

(Note: Definitions of risk in the hazards literature vary from those that equate risk with probability to those that see risk as the product of a probability and a particular kind of impact occurring.)

Risk and Hazard are two concepts that are different from each other. The ocean is a hazard (deep water and large waves). If one attempts to cross the ocean in a small rowboat, a great risk (probability of capsizing and drowning) is incurred. If the crossing is made aboard the Queen Elizabeth, (a large passenger ship) the risk is reduced – all else being equal. The ocean going vessel is a device used as a safeguard against the hazard. In general, risk may be diminished by increasing safeguards but never eliminated unless the hazard itself is removed.

Consequence: The monetary and non-monetary "costs" or "losses" of a hazard event. This includes financial, economic, life safety, environmental, social, legal and other costs or losses. Its assessment may be made easier if the elements at risk are enumerated first.

Elements at risk: Persons, buildings, property, crops, utilities, critical facilities, infrastructure, environment or societal components with a potential of being exposed to a hazard event and likely to be adversely affected by the hazard event.

Elements at risk may be listed as follows:

Table 32 Elements at risk

Physical	Infrastructure, Roads, Railway, Bridges, Harbor, Airport,
Critical facilities	Emergency shelters, Schools, Hospitals and Nursing Homes, Fire Brigades, Police,
Utilities	Power supply, Water supply, Transport, Communication, Government services
Economic	Business and trade activities, Access to work, Impact on work force, Opportunity cost
Societal	Vulnerable age categories, Low income group people, Gender
Environmental	Loss of biodiversity, Damaged landscape, Physical and chemical changes in the surroundings

Quantification of risk: There are three essential components to the quantification of risk after identification of local hazards.

Table 33 Parameters for quantifying risk

Hazard occurrence probability (p)	the probability of occurrence of a specified natural hazard at a specified severity level in a specified future time period.
Elements at risk	an inventory of those people or things, which are exposed to the hazard.
Expected loss (L)	the degree of loss to each element, should a hazard of a given severity occur. Its accuracy and acceptability will depend on the methodology used to derive it.

Disaster losses include the direct impacts like the loss of life, housing and infrastructure as well as indirect impacts on production in utility services, transport, labor supplies, suppliers and markets. Secondary losses include impacts on macroeconomic variables such as economic growth, balance of payments, public spending and inflation. The impacts are felt more by developing countries.

In 1977, a cyclone struck the Andhra Pradesh. The following loss figures were estimated for the East Godavari District – Houses destroyed 2,89,906, Houses damaged 89,677, TOTAL 3,79,583, Persons rendered homeless 1.442 million.

If measures were taken to strengthen houses by retrofitting, the loss would have been reduced as follows –Houses destroyed Nil, Houses damaged 1,36,489, Persons rendered homeless 0.519 million. The economic benefit is estimated to be Rs. 91 crores.

It is advisable that, if a hazard event does occur, that a post-audit be carried out so that one may match the 'actual' Vs the 'expected'. This would give more understanding on deficiencies of the Risk Assessment carried out and help to improve the process next time around.

Note: The probability of occurrence of natural hazards events may be estimated by statistical extrapolation from historical data. The accuracy of such estimates depends on the completeness of data and the period of time over which it has been collected.

Losses are measured differently for different hazards, by different agencies, and by different users. Most loss data are dollar estimates, but some dollar estimates are for specific agencies or only one level of government. The estimates could show variability as well as considerable uncertainties and is valid for only a short period of time.

Risk assessment

It is the overall process of identifying and analyzing risks. The process of characterizing hazards within risk areas, analyzing them for their potential mishap consequences and probabilities of occurrence, and combining the two estimates to reach a risk rating.

Experts on behalf of others carry out assessment of the risk parameters.

Risk Assessment provides a sound basis for mitigation planning and for allocation of funds and other resources.

Some use the term Hazard Vulnerability Analysis (HVA) to express Risk.

It is the process of evaluating risk associated with a specific hazard and defined in terms of probability and frequency of occurrence, magnitude and severity, exposure and consequences.

Frequency vs. Severity: Where flooding occurs every year or every few years, the hazard becomes part of the landscape, and projects are sited and designed with this constraint in mind. Conversely, in an area where a tsunami may strike any time in the next 50 or 100 years, it is difficult to stimulate interest in vulnerability reduction measures even though the damage may be catastrophic. With so long a time horizon, investment in capital-intensive measures may not be economically viable. Rare or low-probability events of great severity are the most difficult to mitigate, and vulnerability reduction may demand risk-aversion measures beyond those justified by economic analysis.

Here, severity means the event's duration and impact area.

There are many methodologies for Risk Assessment from High Tech computer-based methods to pencil pushing and head scratching. Computer-based Geographic Information Systems (GIS) modeling use many different kinds of information to assess risk. However it needs sophisticated hardware, software and expertise of handling them.

Risk matrix: A simpler method is the **Risk Matrix Analysis**. The method gives a qualitative measure that permits the prioritization of risk among multiple hazards. It enables hazard mitigation planners to classify various types of hazards into different categories of priority by locating them on a two-dimensional grid based on their probability and loss. The ranking of 'high', 'moderate' and 'low' is subjective and would vary from one group to another. The ranking depends on Probability of a hazard event and Potential loss.

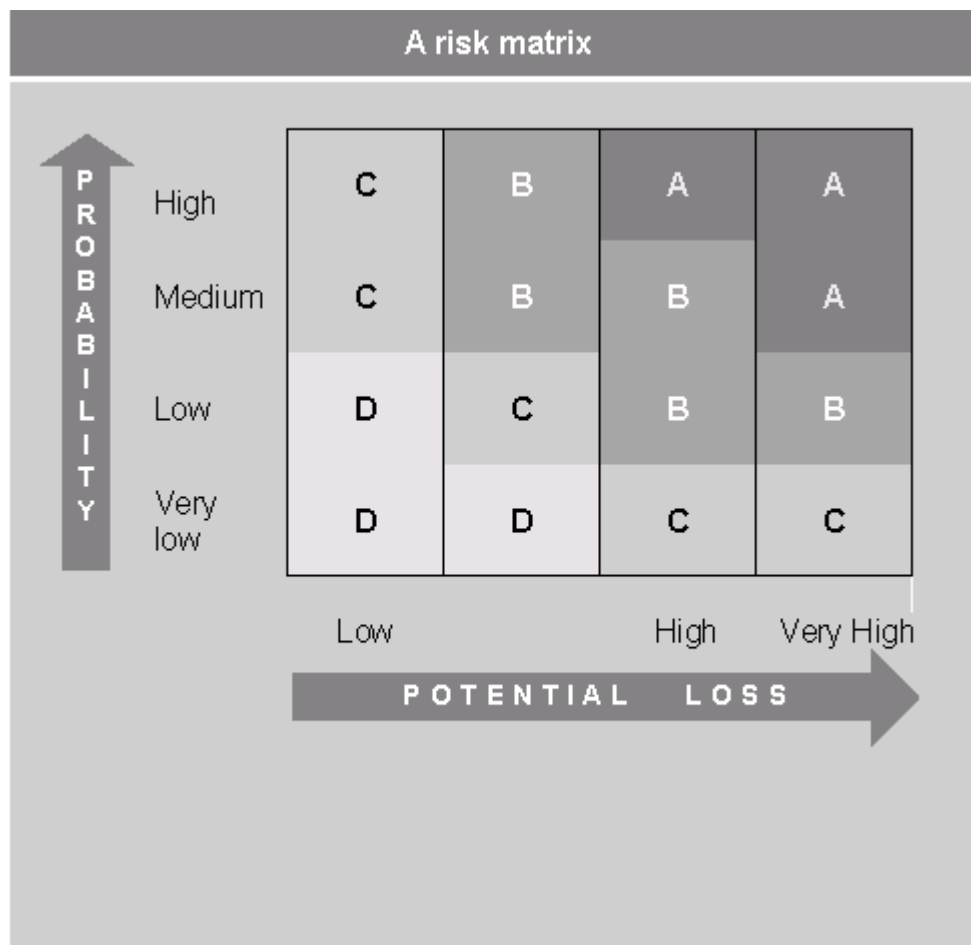

Figure 43 Diagram of risk matrix analysis

Table 34 Guidelines to do a matrix analysis

Probability	High	Events that occur more frequently than once in 10 years
	Moderate	Events that occur from once in 10 years to once in 100 years
	Low	Events that occur from once in 100 years to once in 1000 years
	Very Low	Events that occur less frequently than once in 1000 years
Loss	Based on the potential by taking into account elements at risk	Fatalities Injuries Impact on facilities, critical services and infrastructure Property damage Business interruption Environmental/Economic impact

The criteria used for class categorization is also subjective. What has been given below merely illustrates the type of criteria that countries may adopt to facilitate the process.

Table 35 Risk categorization by class

Class A	High-risk condition	Immediate action is necessary	Possible deaths over 1000	People affected may be over 100,000 Complete shut down of facilities and critical services for more than 14 days. Over 50% of property located in the area may be damaged
Class B	Moderate to high-risk condition where risk can be reduced by mitigation activities and contingency planning	Prompt attention needed	Possible deaths less than 1000	People affected may be between 50,000 to 100,000 Complete shut down of facilities and critical services for 7 days 25% of the property located in the area may be damaged
Class C	Low risk		Possibility of	People affected

	condition However investment in further mitigation and planning may be necessary after cost-benefit analysis		death low	between 10,000 and 50,000 Complete shut down of facilities not more than 1 day. About 10% of the property located in the area may be damaged.
Class D	Very low risk condition Only limited action necessary		No possibility of death	People affected less than 10,000 Facilities and critical services may not be affected. About 1% of the property located in the area may be damaged

Risk as a function of hazard, loss and preparedness. According to Fournier d’Albe (1979), risk may be conceptualized as follows:

Risk = Hazard (probability) x **Loss** (expected)

Preparedness (loss mitigation)

- Physical/material
- Social/organizational
- Attitudinal/motivational aspects.

Thus their quantification cannot be discrete. It is advisable therefore, not to treat this conceptualization as a mathematical entity because of the emotive aspects that are inclusive in “preparedness”. It is wiser to consider that disaster risk is a function of preparedness/capacity/manageability.

Greater the hazard probability, greater the risk.

Greater the loss, greater the risk.

Greater the preparedness or capacity of a community, lesser the risk.

(Capacity and Risk show an inversely proportional relationship)

Risk = function (hazard, loss, preparedness)

Preparedness has an inverse relationship to risk.

29. TECHNICAL ANNEX 18: TRAINING – DISASTER MANAGEMENT

Goal (Session 3)

To instill an understanding of the disaster management process

Learning outcomes

After completing this session, the participant will be able to --

- Affirm the usefulness of integrating management principles in disaster mitigation work
- Distinguish between the different approaches needed to manage pre- during and post- disaster periods
- Explain the process of risk management

Learning objectives

Participant will learn to --

- Distinguish between disaster management and risk management
- Explain the disaster management Cycle
- Describe the strategies for risk mitigation
- List activities needed for post-disaster management

What is Management?

Management consists of decision-making activities undertaken by one or more individuals to direct and coordinate the activities of other people in order to achieve results, which could not be accomplished by any one person acting alone.

Management is required when two or more persons combine their efforts and resources to accomplish a goal, which neither can accomplish alone.

29.1. Disaster Management

What is disaster management?

Disaster management can be defined as the effective organization, direction and utilization of available counter-disaster resources.

Disaster management includes administrative decisions and operational activities that involve – Prevention, Mitigation, Preparedness, Response, Recovery and Rehabilitation.

Disaster management involves all levels of government. Non-governmental and community-based organizations play a vital role in the process.

Modern disaster management goes beyond post-disaster assistance. It now includes pre-disaster planning and preparedness activities, organizational planning, training, information management, public relations and many other fields. Crisis management is important but is only a part of the

responsibility of a disaster manager. The newer paradigm is the Total Risk Management (TRM) which takes a holistic approach to risk reduction.

The traditional approach was to provide immediate humanitarian aid (usually rescue teams, materials and medical services) as quickly as possible after the onset of a disaster. There has been a paradigm shift over the last decade.

The modern view is that there must be pre-disaster mitigation measures to avoid or reduce impact of disasters. Pre-disaster measures to prevent or mitigate disasters are called Risk Management.

Disaster management cycle

The traditional approach to disaster management has been to regard it as a number of phased sequences of action or a continuum. These can be represented as a cycle.

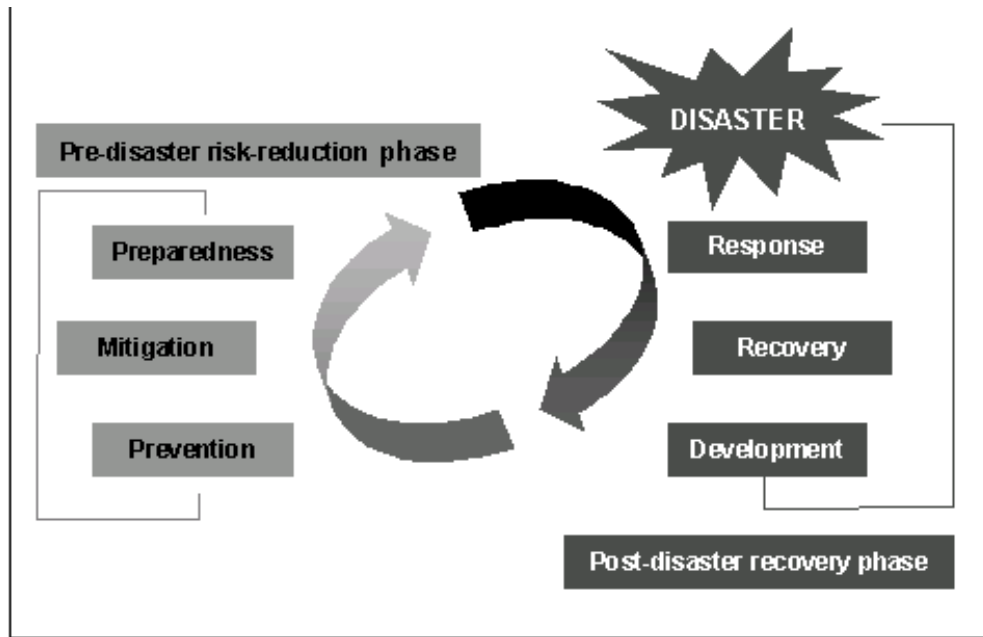

Figure 44 Diagram of the Disaster Management Cycle

In this model, disaster management occurs in stages, in sequence. The focus is more on activities immediately before and after the onset of the disaster event.

Mitigation and preparedness precede a disaster. Pre-disaster management is called Risk Management.

29.2. Risk Management

The process, by which assessed risks are mitigated, minimized or controlled through engineering, management or operational means. This involves the optimal allocation of available resources in support of group goals.

Risk identification has already been discussed. It is usual to allocate risk management to a special body at national level. Usually it is a National Disaster Management Organization (NDMO). At local level it may be the responsibility of a Disaster Mitigation Committee, which administers risk management. This varies in different countries depending on administrative patterns and needs.

Risk reduction

Effective risk reduction involves mitigation measures in hazard prone areas. It may also involve overcoming the socioeconomic, institutional and political barriers to the adoption of effective risk reduction strategies and measures in developing countries.

Mitigation

Measures taken prior to the impact of a hazard event to minimize its effects (which may be structural and non-structural). The following non-structural and structural means may be listed (Carter, 1991)

Non-structural mitigation

Legal framework - Examples are building codes for built structures to withstand impact such as cyclones or earthquakes etc.

Land-use planning - Controlling human activities in hazard prone areas (zoning) to avoid fatalities and loss. This may involve re-location of communities to safer locations. It may be achieved by passing legal statutes, E.g. Ordinances.

Incentives - Often provide better inducements for mitigation than legal impositions. Government grants or subsidies may help to persuade commercial and other institutions to include mitigation measures in their building and reconstruction. Insurance companies may be persuaded to offer reduced premiums for buildings that incorporate hazard resistant measures.

Training and Education - Provide awareness and know-how to those government officials involved in disaster management, construction experts, craftsmen, land use planners and the general public.

Public Awareness - This is necessary to ensure: a good public knowledge and understanding of natural hazards and vulnerabilities, awareness of effective mitigation measures, public participation in community preparedness programs.

Institution building - This is the strengthening of national or community social structure. This can work through; Identifying and strengthening organizations that serve as coping mechanisms: by increasing capacity and skills to face a crisis. Increasing the number of coping mechanisms within a country or community and by linking them to outside resources and Encouraging actions that promote cooperation among different groups within society.

Structural mitigation

Engineered structures - These involve architects and engineers during the planning, designing and construction phases. The application of sound technical principles is achieved through

- Site planning
- Assessment of forces created by natural hazards
- Planning and analysis of structural measures to resist such forces
- Design and proper detailing of structural components
- Construction with suitable material
- Good workmanship under adequate supervision

Most countries have building codes for engineered construction.

Non engineered structures - These are constructions by owners using local masons and carpenters who lack formal training. The design may be improved according to traditional ways. Their location on hazard prone areas may be controlled.

The mitigation plan

The disaster mitigation committee should ‘brainstorm’ on all possible measures that might help to reduce risk. The alternatives should be weighed and the more acceptable ones selected which are appropriate to satisfy community needs. Then a plan must be formulated to facilitate the implementation of the selected risk reduction measures.

29.3. Prevention

Prevention is more applicable to man-made and technological disasters. Stringent safety precautions through technological innovation can bring these about. Natural hazard events cannot be prevented. But if the vulnerability of the community is reduced, one can prevent the hazard event becoming a disaster. The government departments or municipalities can prevent disaster impact by conducting selected mitigation activities before a disaster strikes.

A dam could control floodwater. Controlled burning of fire belts could prevent the spread of a wild fire. Stringent building code imposition can reduce collapse of buildings during an earthquake. Proper socio-economic development and active ownership and participation of communities in the disaster management continuum and the development of adequate warning systems where applicable, can also bring positive results.

29.4. Crisis Management

Crisis management applies to emergency operations and covers Preparedness and Immediate post-disaster period. To avoid confusion during the emergency period immediately after the disaster strikes, disaster management places heavy emphasis on advance planning. This is called disaster preparedness.

A variety of different management systems have evolved to respond to different types of disasters. Most agencies borrowed military and or business organizational models to manage disasters. These used a pyramidal hierarchy of upper-level managers, middle managers and field managers. The upper-level and middle managers dealt with managing the organization and facilitating field operations. The field manager was responsible for development of programs that directly assisted people of the disaster impact area.

Recently, new management models have appeared which emphasize community participation in decision-making and response.

29.5. Response and Relief

If a disaster occurs, response and relief have to take place immediately. Rescue of affected people, distribution of basic supplies such as food water, clothing, shelter and medical care become urgent need of the hour. Delays will occur if government departments and municipalities have no clear plans to manage such events. It is therefore important to have plans in place.

Take a simple example. A flood has occurred in a mountainous area and there is very strong wind and continuous heavy rain. The possibility of landslides is real. Members of the public are panicking and the mayor is under pressure to take emergency action

A well-managed team of government and local players should be prepared and know where to go, what to do. If the situation is managed in an ad-hoc way, the affected people will rush off in all directions, waste valuable time, and even make serious mistakes with fatal consequences.

Search and rescue plans need to be clear and all role players need to know their role and functions in such activities. Basic needs such as emergency shelter, water, food, and medical care have to be provided. A plan must be in place.

29.6. Rehabilitation and Reconstruction

The rehabilitation period involves the weeks and months after the disaster. The focus is to enable the area to start functioning again. This involves debris removal, restoration of public services and provision of temporary housing. Reconstruction is a much longer-term activity. This phase involves permanent rebuilding, improved infrastructure and better disaster planning. Both rehabilitation and reconstruction phases demand good management. Diversion of national and international aid prudently, prioritization of activities, proper coordination and monitoring as well as prevention of corruption and abuse of scarce funds become priorities.

30. TECHNICAL ANNEX 19: TRAINING – PARTICIPATORY RURAL APPRAISAL TOOLS

Goal (Session 4)

To impart knowledge and skill to use tools for participatory appraisal of hazards, vulnerabilities and risks within a community.

Learning Outcomes

- After completing this session, the participant will be able to perform a participatory appraisal of hazards, vulnerabilities and risks for a selected community

Learning Objectives

- Participant will learn to
- Describe the different tools used in participatory appraisal
- Conduct participatory assessment of hazards, vulnerabilities and risks

Content of this session is based on a Hand Book produced by the National Institute of Rural Development (NIRD), Hyderabad, India.

This session will outline tools that have been recommended for working with rural communities. However, PRA tools can be used in almost any situation and need not be confined to appraisal interviews in rural situations.

The major challenges in vulnerability reduction in communities are: sensitization to bring about attitudinal and behavioral change; using participatory techniques to build rapport, elicit support, information and participation of the people in their own development.

30.1. Importance of Participatory Techniques

Participatory techniques aim to ‘break the silence’ of the poor and disadvantaged sections, recognize the value of popular collective knowledge and wisdom and legitimize the production of knowledge by the people themselves. Participatory approaches seek to be catalysts enabling and empowering the people. These have internalized some key techniques in adult training for learning such as

- linking learning to problems,
- linking learning to people’s goals and visions,
- giving trainees control over decisions on training.

The participatory approach emphasizes flexible learning, is adaptable to the pace set by the learners/trainers and tailored to needs expressed by participants themselves.

30.2. Participatory Rural Appraisal

Participatory rural appraisal (PRA) is a methodology to enhance the development agent's understanding of the rural reality for the planning and development of projects; and the feeling of a greater degree of ownership and responsibility in the rural poor for better results and social acceptance of the program. The effectiveness of participatory approaches has led donors, government organizations and NGOs to use PRA in their programs. Participatory training is based on the belief that learners with their life experiences are themselves a rich source of learning; learning cannot be imposed; the learner can only be encouraged to learn; learners learn best by doing or practicing an activity; and learning is facilitated by a positive/successful activity/experience resulting in further achievement, thereby building up a 'virtuous circle'.

30.3. Aims of participatory methods

Different participatory methods are used for different ends. Sometimes participatory approaches are the means and ends as well. In the case of decentralized development, the ends are:

- peoples' active participation in prioritizing needs/micro-planning;
- activating the key local institutions attitudinal and
- behavioral change in the bureaucracy.

Since village organizations have to play an active role in initiating the micro-planning exercise, they need a locally relevant database that is validated by the local people. This will form the basis for setting local priorities. This should help, in turn, in the formulation of local action plans in the form of development activities/projects/programs.

30.4. Scope of PRA

PRA is used

- To ascertain needs
- To establish priorities for development activities
- Within the scope of feasibility studies
- During the implementation phase of projects
- Within the scope of monitoring and evaluation of projects
- For studies of specific topics
- For focusing formal surveys on essential aspects, and identifying conflicting group interests.

Areas of application

- Natural resource management
- Agriculture
- Poverty alleviation/women in development programs
- Health and nutrition
- Preliminary and primary education
- Village and district-level planning
- Institutional and policy analysis.

Table 36 Participatory rural appraisal

Principles and methods		Benefits
From 'they learn from us' to 'we learn from them'.	. From 'we let them participate' to 'they take command of their own process'.	<i>Empowering</i> the poor and weak to assert their priorities, make demands and act.
From 'we've done a PRA' to 'we admit being corrected by people'.	From 'we use instruments from our toolbox' to 'they can map, model, estimate, score, analyze, plan themselves'.	Expression and harnessing of <i>local diversity</i> .
From 'we share our knowledge analysis with them' to 'we enable them to learn from each other and conduct their own analysis'.	<i>Offsetting biases:</i> spatial, project, gender/elite, seasonal calendar.	<i>Community</i> participatory appraisal, planning, implementation, monitoring and evaluation.
<i>Rapid progressive learning</i> , which is flexible, exploratory, interactive and inventive.	<i>Triangulation:</i> using different methods, sources and disciplines, and a range of informants in a range of places and cross checking to get closer to the truth through successive approximations.	Identification of <i>research priorities</i> ; experts more receptive to the ability of rural poor to design, implement and evaluate.
<i>Facilitation:</i> to enable people to do more or all of the investigation themselves and own the outcome.		Insights gained from PRA leading to <i>policy change</i> .
<i>Sharing:</i> a culture of sharing information, methods, field experiences among NGOs, government and villagers.	<i>Behavior and attitudes:</i> critical self-awareness in external facilitators, learning from errors.	A culture of <i>open learning</i> among govt., NGOs and community.

Table 37 Tools of PRA

Diagram		Priority matrix	Seasonal calendar	Time trends	Venn diagram
<i>Map</i> Provides alternative database Depicts	<i>Transect</i> Builds rapport with locals Supports maps of local	Entire community involved in prioritizing needs and	Helps to identify lean periods for	Provides local perspective on time changes in natural resources/ecology/etc.	Helps to identify marginalized individuals and groups

differing local perception of local problems/needs	resources/needs	development initiatives	resources and timing of supply of key farm inputs		within the village
--	-----------------	-------------------------	---	--	--------------------

30.5. Participatory community monitoring and evaluation

Why participatory community monitoring and evaluation?

Participatory community monitoring and evaluation are extremely important for learning about the achievement/deviation from original concerns and problems faced by local development projects/programs being implemented, so that corrective measures can be taken in time.

Evaluation is often carried out by donor agencies or policy makers and helps in assessing whether the project has brought benefits to those for whom it was intended. An evaluator is expected to examine: whether it was right to have invested resources in the project in the context of competing needs; whether the underlying assumptions and design were right; whether progress was made towards planning changes, and if not, why; and unplanned changes that may have occurred.

Monitoring ensures that i) inputs are ready in time; ii) works plans are followed closely; iii) adjustments can be made and corrective action taken as and when necessary; iv) people who need to know are kept informed; v) constraints and bottlenecks are found; and vi) resources are used efficiently.

Aim of participatory monitoring and evaluation (pme)

To assess information or generate data on development activities being carried out at the local community level –

- To facilitate monitoring and evaluation by beneficiaries of different development activities.
- To increase beneficiaries' commitment and understanding in designing, planning and implementing community-based development projects or programs.

Participatory monitoring involves local beneficiaries in measuring, recording, collecting, processing and communicating information to assist local development project extension workers and local group members in decision-making.

Participatory evaluation assists in adjusting and redefining objectives, reorganizing institutional arrangements or re-allocating resources as necessary. Monitoring and evaluation system (MES) allows continuous surveillance in order to assess the local development project's impact on intended beneficiaries.

Involving local people in project evaluation is one of the learning objectives of participatory management. Apart from project's impact on the life of the people, it is also worthwhile to evaluate: i) attitudinal changes in the local community about their role and sense of responsibility; ii) if people have gained confidence in their ability to undertake new activities; and iii) lessons about people's capacity, extent of participation and community responsibilities.

It provides an opportunity to the project implementation committee to assess deficiencies in the project design - if objectives and work plan were realistic, if local funding was adequate and whether project actually owned by the people. Answers to these questions indicate future precautions and modifications in the method and approach. This in itself is an achievement in capacity building at the local level.

Role of community extension workers

It is the responsibility of extension workers/community development motivators to make beneficiaries aware about the project/programs and their objectives. Extension workers should develop and help beneficiaries identify *indicators and measurements* for each project activity. Based on these, extension workers should collect data on inputs and outputs by using simple formats and tables. Extension workers should *process, organize and analyze* the data for evaluation. For participatory evaluation, they should assist beneficiaries to understand the process, using simple procedures. After processing, organizing and analyzing the data, extension workers must *assess the impact* of local development project activities.

PME should be:

- Demonstrative, not instructive in writing
- Collaborative, not individualist or directive
- Explorative, not repetitive
- Listening to, not lecturing
- Interactive, not dominating
- Qualitative, not quantitative
- For community/people, not project-oriented.

Table 38 Steps in participatory monitoring and evaluation (PME)

<i>Step I</i>	Understanding goal/objectives of local development project/program.
<i>Step II</i>	Identifying activities to achieve objectives.
<i>Step III</i>	Identifying measurements to assess results or show extent of progress achieved.
<i>Step IV</i>	Developing measurement indicators.
<i>Step V</i>	Identifying methods and techniques of collecting information.
<i>Step VI</i>	Selecting formats/visual tools for presenting information

31. TECHNICAL ANNEX 20: TRAINING – COMMUNITY PUBLIC AWARENESS

Goal (Session 5)

To impart an understanding of public awareness creation

Learning Outcome

- The participant will be able to explain the process of public awareness creation

Learning Objectives

- Participant will learn to
- Explain situation analysis
- Describe audience analysis and audience segmentation
- Achieve SMART objective setting
- Understand the process of message creation
- Discriminate between available channels for message dissemination
- Evaluate effectiveness of public awareness activities

31.1. Definition of Social Change Communication Campaign

Some generic definitions for social change communication campaigns:

Programs designed to influence the voluntary behavior of target audiences where the primary objective is to improve the welfare of the target audiences and/or the society of which they are part (Andreasen, 1995)

A target audience-based approach to promote socially beneficial behavior change in specific populations

It is much more than education; it includes analysis, planning, execution, and evaluation of integrated programs to influence people to trade their old ideas, beliefs, and behaviors for new ones.

You want to change people's behaviors, but that's not your only outcome. You've got to change the environment.

As figuratively defined by someone, "An idea attached to leadership". Very often, the "change" social change communication campaigns seek is in *knowledge, attitudes, skills* and *practice*. A larger definition is that community norms need to change so that the targeted knowledge, attitude and practice changes become acceptable. Further, social change campaigns may also seek societal level changes such as change in policy.

31.2. Definition of Disaster Risk Communication

Disaster Risk Communication is a specific application of social change communication campaigns to bring about change in knowledge, attitude, skills and practice at the individual and possibly societal level with regard to disasters.

Specifically, DRC is: “The systematic planning of information transfer, based on scientific research, to prevent, solve or mitigate the risk problem with adjusted and customized information (risk messages) for specific target groups” (Gutteling and Wiegman, 1996). The authors of this definition also point out that the communication can be multi-way suggesting that it is not just a transfer of information. Let us try to understand each part of this definition.

Systematic Planning

The term currently in use for communication campaigns is “public awareness.” Public awareness draws on the mass media to create awareness in society about the development intervention, while social marketing uses marketing ideas, i.e., the integrated use of channels, cost, intervention, promotional ideas, etc., to promote and deliver social change interventions. What is relevant is that any serious communication campaign, in this case for disaster risk communication, must be based on systematic planning.

The generic communication model (Lasswell, 1948) is: Who? Says what? To whom? With what effect?

It is critical that the “What” itself be determined based on feedback, so that both the content of the message itself and the language/design, etc., used to convey the content is relevant and representative of the target group, and clarity is assured (or in communication jargon noise is reduced). That is, rather than “transfer” alone, the approach should be a mutual determination of the message and then its communication to the larger target group.

The definition leaves out the “Who” or the source of the message. Sources of messages must be:

- *Knowledgeable*: Content experts must be used for technical message content in mediated messages. While this might be routinely done for mass mediated messages, the need to impart content knowledge to interpersonal communication sources, particularly local level implementing officials, community opinion leaders, and volunteers is critical.
- *Credible/Trustworthy*: Whether it is a medium (radio, newspaper, television) or an interpersonal source (government official), the source must be credible to the target and one that the target group trusts.

The two characteristics are intertwined so that credibility may lead to trust and vice versa, but depending on the campaign sometimes it is credibility and at other times it is trustworthiness that is more important.

Also, while knowledge lends credibility, it is not the only determinant of credibility. Sometimes likeability may also determine credibility.

- *Likeable*: Likeability may be related to all the above concepts but is also related to attractiveness of the source and to the next characteristic of a source, representative ness.
- *Representative*: A representative source is one who looks like, speaks like, and dresses like the target audience. People are more able to relate to and understand sources that are similar to them.

Scientific Research

The importance of research, systematic, planned, scientific, is often overlooked. Research informs each stage of the communication campaign and helps to ensure that decisions are made on the basis of fact rather than whim or opinion alone. Often when campaigns may fail, the temptation is to blame the ignorant public without looking at whether risk perception was accurate, whether the message was the right one, presented in the right manner, for the right public, etc. Research assists with these decisions.

Problem definition: At this stage, there may be a disjoint in what the agency that is creating the campaign perceives as the problem and what the target group sees as a problem. While we are specifically interested in problems that can be solved by communication, we must be alert to the fact that some non-communication problem may be the larger problem. It is of course assumed that before we get to the stage of a communication campaign, it has been determined based on research that a communication problem is present. Still taking the target audience's views even in defining the communication problem is important.

Research at this stage may be largely qualitative and secondary (i.e., collected from existing materials rather than gathered from scratch) supplemented by quantitative and primary (i.e., gathered specifically for the purpose).

Target audience definition: At this stage, research must be undertaken to provide a complete profile of the target audience starting with demographics. Such a profile is critical for the selection of messages, tactics, channels, sources, and such.

Research at this stage is largely quantitative and primary but also qualitative and secondary.

Delineation of strategy: The main message strategy (i.e., the big message idea) must be based on research into the problem and the target, but must be finalized based on testing with the target audience. This may require both secondary and primary research, and both qualitative and quantitative research.

Message creation: Three broad stages of message creation are concept, rough (sketch of the idea), and comprehensive (close to final). At each of these stages, feedback from the target group is essential. Essentially, this is pre-testing the message. Research at this stage is largely quantitative and primary but also qualitative sometimes.

Channel determination: This is largely based on research into the target audience's channel profile (and knowledge of the strengths of each medium).

Evaluation: Evaluation is conducted before, during and after the campaign respectively to establish a baseline, to see if the campaign is working and make adjustments if necessary, and to measure the success of the campaign.

Largely, primary quantitative evaluation is done but qualitative evaluation is also used.

Prevent, Solve, Mitigate Risk Problem This is the main goal of the disaster risk communication campaign.

Specific objectives will also need to be articulated as building blocks through the use of communication to achieve this larger goal.

Adjusted and Customized Risk Messages

The messages themselves are composed of the content as well as the language, design, etc., used in constructing them. Messages need to be adjusted as noted above based on pre-campaign feedback and concurrent campaign evaluation. They must also be customized to different target audiences or sub groups within audiences, to different channels, and for different times of the year or day, etc.

Target Groups

As mentioned above, the target audience must be profiled in depth. Any campaign may be targeted at more than one target audience (this does not imply that the same message, media, etc., be used for each group).

These groups may be --

- Policy makers who, for example, may need to be convinced to make disaster preparedness a priority or to reform building codes. This includes local, regional and central bodies that determine and implement policies and practices.
- Community members (and social networks) who may need to change formal and informal social norms or standards, for example, in terms of acceptance of education for females.
- Institutions and organizations that may assist in the campaign by becoming venues. These include businesses, schools, religious institutions, public agencies, service organizations, trade or professional associations.
- Interpersonal groups includes primary groups such as peers, family and friends that provide social identity, support and role delineation for an individual and may be able to influence change in individuals.
- Individuals who may change their cognitive, psychological, and behavioral makeup, i.e., their knowledge, beliefs and attitudes, personality and action. Often in DRC campaigns, change at the individual level is the major component.

31.3. Steps in DRC

The broad basic steps in DRC (all of which are informed by research) are (see more details in appendix):

- **Situation Analysis:** Study the situation with regard to the problem, its history, past attempts to resolve the problem, etc.
- **Target Audience Definition:** Determine your specific target audience(s) and profile it.
- **Formulating Communication and Action Objectives:** Outline objectives of the DRC in terms of communication and action outcomes at several levels as appropriate from the individual to societal.
- **Formulating Message Strategy and Tactics:** Determine the main message(s) and the different ways of presenting the message.
- **Formulating Channel Objectives, Strategy and Tactics:** Determine the channel including interpersonal sources through which the message(s) will be communicated.
- **Producing Materials and Implementing Campaign**
- **Monitoring and Evaluation:** Determine how to monitor the progress of the project and to evaluate its success.

DRC is important because:

- It empowers people. Most DRC campaigns have the public as their target audience. By providing the public with information, DRC campaigns empower them to control their lives and give them strategies on how to cope when disasters strike. This empowerment can help reduce the fatalistic attitude that one finds in many regions and ultimately save lives and livelihood, the most critical resources of any country.
- DRC campaigns also enable policy change. This end result comes not only from the fact that policy makers may be the target group for the campaign, but also from the fact that the empowered public can create public opinion pressure to bring about change at the policy level.
- DRC campaigns also make the work of disaster relief a lot easier. If people have an accurate perception of the risk to them, and know what to do and how to respond when the risk is present, relief agencies will have less work because fewer lives will be at stake and more people will have followed directions. That is, people will be better prepared and the work of agencies will be more effective.

31.4. Barriers to Making Change

While the need for DRC is urgent, there are barriers to making change that DRC campaigns must keep in mind:

- **Negative demand:** Target audiences who are being reached by such campaigns may not want it (Andreason, 2000).
- **High involvement issues:** Many of the behaviors these campaigns try to influence are much more involving, serious.
- **Invisible benefits:** Often times, the benefits of these campaigns are not immediate and obvious.
- **Benefits to others:** Often times, the benefits of these campaigns accrue to others.

Thus making social change is difficult, but the tools presented in this workshop will assist in the endeavor. Apart from barriers to change, there are also factors that could become points of resistance. These must be identified and dealt with. Resistance points may be:

- social
- cultural
- economic
- religious
- products of ignorance

31.5. Some Distinctions

“Communication for development” is a researched and planned process which is crucial for social transformation, operating through three main strategies:

- *Advocacy* to raise resources and political and social leadership commitment for development goals; Advocacy is a continuous and adaptive process of gathering, organizing and formulating information into argument, to be communicated through various interpersonal and media channels, with a view to raising resources or gaining political and social leadership and commitment for a development program, thereby preparing a society for its acceptance.’
- *Social mobilization* for wider participation and ownership; and Social Mobilization is the process of bringing together all feasible and practical inter-sectoral social partners and allies to determine felt-need and raise awareness of, and demand for, a particular development objective. It involves enlisting the participation of such actors, including institutions, groups, networks and communities, in identifying, raising, and managing human and material resources, thereby increasing and strengthening self-reliance and sustainability of achievements.’
- *Program communication* for changes in knowledge, attitudes and practices of specific participants in programs; Program communication is a research-based, consultative process of addressing knowledge, attitudes and practices through identifying, analyzing and segmenting audiences and participants in programs and by providing them with relevant information and motivation through well-defined strategies, using an appropriate mix of interpersonal, group and mass-media channels, including participatory methods.’

When combined with strategies for the development of appropriate skills and capacities, and the provision of an enabling environment, communication plays a central role in positive behavior development, behavior change and the empowerment of individuals and groups.”

31.6. Partnerships

You do not have to go it alone in a DRC campaign. Often, partnerships are developed which are very fruitful because they --

- Reduce the cost of the project to you
- Develop long-term and more sustainable solutions if several partners are involved
- Local partners particularly assist with local contacts, culture, etc.
- They may take you out of the rut and routine that you are used to in doing your campaigns

Partnerships are not however without problems. They could not carry their load, their ideas and yours might be so divergent that consensus becomes difficult, they may go off strategy and do their own thing, you may feel loss of ownership, etc. Ultimately you may feel you are spending more time on managing partnership dynamics than if you had done it yourself. Hence great care needs to be exercised in selecting partners. Research the partnership choices you have:

- Look for what mutual benefits can accrue from each
- Look at financial stability
- Look for compatibility of personalities
- Look for compatibility of ideas and approaches
- Look for complementary skills

Once you have selected a partner(s), very clearly define the roles and responsibilities of each in terms of work, finances, etc. This is critical to forestalling problems.

31.7. DRC Budget

The budget for your DRC campaign is an important consideration. Sometimes you may have a defined budget within which you have to develop your DRC campaign. Thinking through your campaign in a systematic fashion through objectives may in fact assist you to exploit your predetermined budget to its fullest. You may need to make some hard choices, but if they are based on good strategy they may be easier to make.

On the other hand, you may be able to develop a DRC campaign and develop a budget for it. In this case, the systematic planning of your DRC campaign will provide a strong rationale for each of your decisions and therefore for your budget making it easier for you to convince potential donors or government agencies to support your project.

At the same time recognize that budgets are always limited. Responsible budgeting and ultimately responsible spending of budgets will increase your credibility.

Also recognize, that the process of budgeting is not necessarily linear. That is, you may not be able to plan a full campaign and then begin the budgeting. Often as you are considering options, you will have to get rough quotes to compare and make decisions. Sometimes this assists in developing solutions you may not have thought of earlier. Local input is of very great importance at this stage in finding alternatives, in exploring options, and in getting good deals because of local relationships.

As you budget, make sure you consider every expense. A DRC campaign plan is therefore very useful in ensuring that you do not overlook any expenses. Remember the tangible items, such as X number of booklets, may be easy to price. It is the intangibles such as time spent on preparing for an event that may tend to be poorly budgeted. Take a step-by-step approach, creating a line item for each step. Later after each step has been listed and costed chronologically, you may regroup into major categories that belong together. The chronological method keeps you from leaving anything out. A media budget recap sheet might also be very helpful for your media buys. This sheet should show spending for each medium and total media spending.

As you budget, do not forget that you may find local donors who may be willing to provide some items free either because it is a good cause or for the publicity that your campaign might be able to generate for them. The media might be willing to provide free space and time for a good cause. Remember that developing a relationship with a vendor might also assist in reducing costs. Further, bulk business with a vendor is another possibility to explore. The advantage of this is that it gets the local community involved in the effort.

The basic idea in budgeting is to achieve maximum benefit from the least amount of money. This is a good principle to keep in mind but a difficult one to measure and operationalize. Another similar principle is that there is a level beyond which spending more money will not help. There are some people you are never going to reach with your message, there are others you are going to reach but with no effect on them. In both of these matters, past experience can play a critical role.

Some of the major expenses in a campaign are:

- *Materials* - design and production (includes writing, photographing, illustrations, layout, video, audio, web sites, talent, etc.)
- *Media Buys* - The time and space you will buy on various channels
- *Personnel* - Project implementation once the campaign is planned; research implementation at various stages starting with the situation analysis to post-campaign evaluation; training for research, project implementation, etc.; travel expenses
- *Contingency* - Generally set aside a percent (usually 10%) for contingencies.

32. TECHNICAL ANNEX 21: TRAINING – EARLY WARNING

Goal (Session 6)

To provide an understanding of early warnings

Learning Outcome

- The participant will be able to formulate strategies for dissemination of early warnings to the community

Learning Objectives

- Participant will learn to
- Discriminate between hazard specific warnings
- Formulate and implement appropriate warning dissemination through the community

32.1. Classification of disasters for early warning activities

Disasters can be classified by nature, timing, predictability, response time and type of impact.

Table 39 Disasters according to timing

<i>Slow</i>	<i>Quick</i>
Drought Famine Coastal Erosion	Flood Cyclone Earthquake Tsunami Landslide

Table 40 Disasters according to predictability

<i>Predictable</i>	<i>Unpredictable</i>
Drought	Earthquake
Flood	Earthquake
Coastal Erosion	Landslide
Cyclone	

Table 41 Disasters according to response time

<i>Long response time</i>	<i>2-3 days response time or less</i>	<i>1-2 hours Response time or less</i>	<i>No response time</i>
Drought Famine	Cyclone Floods	Tsunami Flash Flood Landslide	Earthquake

Pre-impact/response

- Forecast
- Early warning
- Preparedness
- Tracking/monitoring approach of disaster
- Alertness/evacuation

32.2. Warning Systems

Forecasting helps to issue early warnings of disasters; the warning should be communicated to the community through a warning system. This may be

- Alarms – like a fire alarm
- Sirens
- Public Announcements through Radio, TV (Cyclones, Floods, Landslides)
- Traditional communication systems in villages (temple bell, drums, hoisting of flags etc.)

32.3. Important Issues

- It must be noted that opportunity for warning does not exist in all cases.
- Indiscriminate warnings may result in non-responsiveness of people.
- A designated responsible person must always issue warnings
- All warning systems and technologies must be maintained in working condition and checked regularly
- Communities in disaster prone areas must be made aware of the warning systems.
- Alternative warning systems must be kept in readiness in case of technological failure or power failure.
- Only the delegated person will issue warning.
- All available warning systems should be used. Each warning system has limited reach and multiple warning systems will help reinforcement.
- The warning should be very clear about the severity, the time frame and the area that may be affected to the extent possible.
- Community should be made aware of the **DO's** and **DON'T's** after the warning as a preparedness activity well ahead.
- Warnings should not evoke panic. It must be devoid of emotions.
- Rumor control action should be taken.
- Wherever possible get the assistance of community leaders and organized groups within the community.
- Latest situation reports must follow the warning.
- If the disaster threat fades away an all-clear signal must be given.
- Evacuation
- It is important to understand the nature of the threat and the procedures to be adopted.
- All agencies involved in evacuation must have a common understanding of their roles and responsibilities in order to avoid confusion and panic.
- Different situations demand different priorities and hence the responsibility of ordering an evacuation is assigned to different agencies. The EOC, the Divisional Secretariat, Police and Fire Brigade will only order evacuation.
- Evacuation should involve community leaders.
- All evacuations must be reported to the Divisional Secretariat.

32.4. Evacuation Preparedness Responsibility

Table 42 Evacuation preparedness responsibility

Preparedness/ Function	Responsibility
<ul style="list-style-type: none"> ▪ To warn people about the impending danger & to leave for safer places 	<ul style="list-style-type: none"> ✓ DS, GN. Police, Fire Brigade ✓ Irrigation (flood) ✓ Met Dept. (flood, cyclone) ✓ NBRO (landslides) ✓ Health (epidemics) ✓ Police (Road Accidents, Industrial and Chemical Accidents) ✓ Geological Survey & Mines Bureau, GSMB (E'quakes, Tsunami) ✓ Leading NGOs
<ul style="list-style-type: none"> ▪ To co-ordinate with State-Civil Defense/Police/NGOs/CBOs 	<ul style="list-style-type: none"> ✓ District/Divisional Secretaries ✓ Police ✓ Leading NGOs/CBOs
<ul style="list-style-type: none"> ▪ Arrangement of Boats/ vehicles etc for speedy evacuation 	<ul style="list-style-type: none"> ✓ District/Divisional Secretaries ✓ Police/Army/Navy/Air Force ✓ Leading NGOs/CBOs
<ul style="list-style-type: none"> ▪ Evacuate people of stranded areas 	
<ul style="list-style-type: none"> ▪ Organize trained task force members 	
<ul style="list-style-type: none"> ▪ Maintaining Law and Order 	<ul style="list-style-type: none"> ✓ District/Divisional Secretaries ✓ Police/ Army/Navy/Air Force
<ul style="list-style-type: none"> ▪ Mobilize people to go to safe places 	<ul style="list-style-type: none"> ✓ Divisional Sec., GN, ✓ Village Disaster Management Committee ✓ Village Volunteers ✓ Police/Army/Navy/Air Force
<ul style="list-style-type: none"> ▪ Deployment of Boats for evacuation 	

33. TECHNICAL ANNEX 22: TRAINING – RESPONSE PLANNING

Goal (Session 7)

To provide ability for Response Planning

Learning Outcomes

- The participant will be able to formulate a Community Response Plan in collaboration with the community

Learning Objectives

- Participant will learn to
- Discriminate between House Hold Response Plan, Institutional (e.g. School) Response Plan and Community Response Plan
- Understand the elements of an Evacuation Plan
- Formulate an Evacuation Plan
- Conduct an Evacuation Drill
- Evaluate the effectiveness of the Drill

33.1. Introduction

Response planning helps to prepare people to face a disaster situation. Each District with the leadership of the District Secretary will form a District Disaster Management Committee (DDMC). This will act as the Emergency Management and Response committee in the aftermath of a disaster. Activities identified for emergency response are

- ❑ Early Warning
- ❑ Evacuation
- ❑ Identification of camps for displaced persons
- ❑ Search and rescue
- ❑ Post disaster assessment
- ❑ Emergency relief
- ❑ Logistics and supply
- ❑ Communication and information management
- ❑ Survivor response and coping
- ❑ Safety
- ❑ Security
- ❑ Emergency operations management

The Emergency Operations Centre (EOC) will be the focal point of operations control with the District Secretary, Divisional Secretaries, District/Provincial Heads of Departments and Government Agencies and other major stakeholders.

Response planning can be done at several levels.

- Family
- Institutional e.g. School, Office, Factory etc.
- Community and GN division
- Divisional
- District
- Provincial
- National

It is important that plans must conform to each other. Therefore it is advisable that all response plans are vetted by the DDMC.

This session concentrates on the community level response. People can – and do – cope with disaster by preparing in advance and working as a team. Helping people know what to do is the best protection.

33.2. What to Know? What to Plan

- ❑ Conduct a hazard assessment of the community to identify any hazards that may exist and could cause an emergency. This is best done through a participatory approach. Involve community leaders and the Grama Niladhari.
- ❑ Discuss the types of disasters that are most likely to happen. Understand what to do in each case. Grama Niladhari can get help from the DDMC in the event you need outside help to do this.
- ❑ Make a list of key personnel with contact information as well as contact information for local NGO emergency responders, agencies and police.
- ❑ Identify vulnerable areas and mark households that should evacuate for safety
- ❑ Find out who needs help such as elderly, disabled persons, pregnant women, young children and where they reside.
- ❑ Identify safe shelters for evacuation and best routes to take in the event of a disaster.
- ❑ Identify relief goods and services as well as logistics needed at evacuation shelters. Who would be able to undertake them (resource mapping)?
- ❑ Identify persons who would manage evacuation shelters. What should they know and be able to do?
- ❑ Learn about your community's warning signals: what they sound like, how best to disseminate them, and what people should do when they hear them.
- ❑ Ask about animal care after disaster. Animals may not be allowed inside emergency shelters due to health regulations.
- ❑ Find out about the disaster plans at workplaces, children's school or daycare centers.

33.3. Evacuation Policy and Procedure

All people involved in evacuation must have a common understanding of their roles and responsibilities in order to avoid confusion and panicky behavior. The community plan must identify a clear chain of command and designate a person authorized to order an evacuation. The EOC, District

Secretary or the Divisional Secretary, Police and Fire Brigade are the only authorized entities to order an evacuation. Therefore the evacuation must be done in concurrence with any of them. The Police must be notified immediately after the evacuation.

It is common practice to select a responsible individual to lead and coordinate your emergency plan and evacuation. It is critical that community know who the coordinator is and understand that this person has the authority to make decisions during emergencies. The coordinator should be responsible for assessing the situation to oversee emergency procedures, notifying and coordinating with outside emergency services.

- The community plan must address procedures for assisting people during evacuations, particularly the sick, the elderly, the young and those with disabilities. Designate individuals as evacuation wardens to help move people from danger to safe areas during an emergency. Generally, one warden for every 20 people should be adequate, and the appropriate number of wardens should be available at all times.
- Encourage an entire family to evacuate together as a unit.
- Identify one or more assembly areas (as necessary for different types of emergencies and available time) where people will gather first before proceeding to shelters and a method for accounting for all persons worked out.

Accounting for all persons following an evacuation is critical. Confusion in the assembly areas can lead to delays in helping disabled, or unnecessary and dangerous search-and-rescue operations. To ensure the fastest, most accurate accounting of your community members, consider taking a head count after the evacuation. The names and last known locations of anyone not accounted for should be passed on to the official in charge.

- Amount of time needed for evacuation will depend on the disaster.
- As much as possible, the shelter sites should be within walking distance.
- Show evacuation routes with proper sign boards for different types of disasters. The extent of evacuation may be different for different types of hazards.
- Evacuation routes should be well lit at night, wide enough to accommodate the number of evacuating personnel, unobstructed and clear of debris at all times, and unlikely to expose evacuating personnel to additional hazards.

33.4. House Hold Level Preparation

- Wear long-sleeved shirts, long pants and sturdy shoes so you can be protected as much as possible. Avoid dresses that impede speedy walking where necessary.
- Turn off electricity and water. Turn off electricity at the main fuse or breaker, and turn off water at the main valve. Turn off gas cylinder.
- Take your disaster supplies kit.

If you have only moments before leaving, grab these things and go! Have them packaged in anticipation of evacuation!

- Flashlight with plenty of extra batteries
- Battery-powered radio with extra batteries
- First aid kit

- Prescription medications in their original bottle, plus copies of the prescriptions
- Eyeglasses (with a copy of the prescription)
- Water (at least one gallon per person is recommended; more is better)
- Foods that do not require refrigeration or cooking
- Items that infants and elderly household members may require
- Medical equipment and devices, such as dentures, crutches, prostheses, etc.
- Change of clothes for each household member
- Sleeping bag or bedroll and pillow for each household member
- Checkbook, cash, and credit cards
- Lock your home.
- Set pets and livestock free. They will not be allowed inside shelter.
- Use identified evacuation routes — don't use shortcuts because certain areas may be impassable or dangerous. Stay away from downed power lines.

If warning time is adequate

- Make arrangements for pets and livestock accommodation
- If high winds are expected, cover the outside of all windows of your home. Use shutters that are rated to provide significant protection from windblown debris, or fit plywood coverings over all windows.
- Protect your valuables
 - Move objects that may get damaged by wind or water to safer areas of your home. Move television sets, computers, stereo and electronic equipment, and easily moveable appliances like a microwave oven to higher levels of your home and away from windows. Wrap them in sheets, blankets, or polythene.
 - Make a visual or written record of all of your household possessions. Record model and serial numbers. This list could help you prove the value of what you owned if those possessions are damaged or destroyed, and can assist you to claim deductions on taxes.
 - Do this for all items in your home, including expensive items such as sofas, chairs, tables, beds, chests, wall units, and any other furniture too heavy to move.
 - Store a copy of the record somewhere away from home, such as in a safe deposit box.

33.5. Training and Drills

- Does the community plan identify how and when community members will be trained so that they understand the types of emergencies that may occur, their responsibilities and actions as outlined in the plan?
- Does the plan address if and how often drills will be conducted? Once you have reviewed your emergency action plan and everyone has had the proper training, it is a good idea to hold practice drills as often as necessary to keep people prepared. Include outside resources such as
 - fire and police departments when possible. After each drill, evaluate the
 - effectiveness of the drill. Identify the strengths and weaknesses of your plan and work to improve it.

34. TECHNICAL ANNEX 23: TRAINING –MONITORING AND EVALUATION

Goal (Session 8)

To create an understanding of the need for and methods of monitoring and evaluation.

Learning Outcomes

- The participant will be able to understand the importance of monitoring and evaluation and of techniques for conducting them and using their results.

Learning Objectives

- The participant will learn to
- Explain the difference between monitoring and evaluation
- Understand the importance of these two aspects to measure success of a project
- Apply monitoring techniques (How? Who? What?)
- Apply evaluation techniques (How? Who? Scope? When?)
- Explain monitoring and evaluation terminology, techniques, and designs
- Understand the need for and techniques for documentation.

34.1. Definition of Monitoring and Evaluation

Monitoring

Monitoring refers to tracking the progress of your campaign as it is being implemented. It is concerned more with implementation details, problems and adjustments in them, and not essentially with whether the campaign's communication and action objectives are being met.

Evaluation

Whether program objectives are being met or not falls under the purview of evaluation. Evaluation is assessing gains in the effects desired. Evaluation is therefore conducted against the communication and action objectives.

Difference between Monitoring and Evaluation

While some people do not make this distinction between monitoring and evaluation and often include evaluation in monitoring, it is a useful difference to keep in mind. Monitoring is essentially done to make sure everything (activities, visits, distribution, media placement, etc.) is taking place as it was planned. Evaluation, on the other hand, is to assess whether these things (activities, visits, distribution, media placement, etc.) resulted in the effects desired, i.e., whether knowledge increased, for example.

34.2. Place of Monitoring and Evaluation in DRC

Monitoring

Monitoring will enable you to keep ahead of the campaign, ensure quality control, keep your staff/volunteers/implementers alert and on the go, and such. When a campaign is very tightly planned so that certain activities logically follow others, then failure in implementing one aspect of the campaign affects all subsequent stages.

Evaluation

While monitoring is met with less apprehension and is generally included in DRC campaigns, evaluation is often not conducted at all or at least not conducted as systematically as necessary. This may be due to the fear that results may not be as positive as expected or due to the lack of realization of the importance of evaluation or simply due to lack of budget or even skills. None of these are really good reasons for not conducting an evaluation. Further, in this day and time, funding agencies are more and more focused on accountability, and evaluation ensures accountability.

There are several good reasons to do an evaluation:

- Primarily, results are useful in your own campaign. Respond to them in real time. If you find that KASP levels are not rising at the rate expected, find out the source of the problem (lack of distribution of message, garbled message, inaccessibility to message, etc.) and fix it. The problem may lie in the message, in the people or media delivering the message, in the timing, and in a host of other places. Identify these causes and move fast to eliminate them so that the campaign is back on track as soon as possible and problems do not snowball and have a chain reaction. In essence, making these adjustments as problems are identified is iterative.
- Results will be useful to others working in the same field. Particularly in the field of disasters, literature on DRC campaigns is scarce.
- Unexpected things can happen and derail even the best planned campaigns, but if your campaign was informed by research at each stage, then the results of the evaluation should most likely indicate strides in achieving objectives. This will boost your confidence and convince others of the merits of your work.

A certain amount of planning and foresight will keep evaluation from becoming an object of fear or a burden.

- Set realistic communication and action objectives at the start of the campaign. Changes in most variables do not occur easily and overnight and are only incremental in nature not drastic. Most people make the mistake of setting unreal goals or confusing expected results from communication and action objectives. Remember communication objectives can make people aware or create knowledge, recall, etc., but may not result in action unless other elements are in place in the campaign.
- Budget for evaluation from the very start. Evaluation is important enough that you must plan for it in terms of budget. Remember this involves not just money but also staff time and expertise.
- Make the budget large enough to do a systematic evaluation. Do not conduct a half-baked evaluation. You will then end up making unfounded conclusions about the success or failure of the campaign.

- Develop skills in evaluation or engage an expert to conduct it. Evaluation is serious business. It requires skill if it is to be done right. Either develop your own skills or engage an expert to conduct it.

If your campaign is not having an effect, an evaluation will indicate that and you may be able to make improvements in time to save it. Otherwise you will continue to spend resources on an ineffective campaign.

34.3. Monitoring Plan and Mechanism

While it may not be possible to anticipate everything, it is a good idea to put a monitoring plan in place before campaign start, and to begin monitoring activity from the beginning of the campaign. This plan should detail who will check on what activity (all major activities must be tracked), when (at very regular intervals such as daily/weekly if the activity is ongoing or at time of activity if activity is a one-timer), where (actual site visits, from office, etc.), and how (see below). A chart that outlines this will be very useful in keeping staff and monitoring on track.

The monitoring mechanisms (the “how” of the monitoring plan) might be simply counting brochures, or making sure the posters were distributed on a certain date, or ensuring that the media ran the campaign notice of a contest in time. Here are some mechanisms that may be used:

- Materials inventory
- Materials placement audit
- Materials distribution audit
- Media logs, tear sheets
- Budget assessment
- Timeline assessment
- Staff meetings and reports

A very useful tool is a calendar with considerable detail entered (when, where, how many, etc.) on every activity that needs to take place. Such a calendar will be useful to implementers as well as to the monitoring staff. A master calendar in the head office with copies for implementers (volunteers, officials, etc.) would ensure shared knowledge of the timing, type and scope of each activity. Each one of your partners, implementers, volunteers, etc., would know how crucial they are to the complete plan and how the success of other activities is dependent on their success in delivering on their responsibilities. The calendar also makes very clear the consequences of failing to get any one activity done in time or in the scope planned. Similarly, monitoring staff can identify the activities to be monitored on this calendar and use it as a scheduling guide for their monitoring activities. Calendar apart, staff will have to be trained to conduct the monitoring and to file monitoring reports.

34.4. Evaluation Terminology

There is considerable difference in the use of terminology for evaluation. Simply, however, evaluation may take place:

- During the campaign (concurrent evaluation) and at its finish (post-campaign evaluation).

- Concurrent evaluation may be one time (mid-campaign, for example) or at multiple points in time (critical moments).
- Post-campaign evaluation may be done one time (immediately on close of campaign) or at repeated intervals after post-campaign evaluation. The latter is done to see if campaign effects are long-term but it is also rather expensive to continue evaluation.
- Terminology you may be familiar with is:
- Process evaluation (concurrent evaluation) and summative evaluation (post-campaign evaluation). The term process evaluation is sometimes also used to refer to monitoring activities.
- Summative evaluation is of two types: outcome and impact.
- Outcome evaluation is the linking of program objectives and gains made in desired effects. It assesses individual level changes. Conducting individual level data as part of outcome evaluation has many advantages other than providing a direct measure of campaign success against objectives. Such data can be analyzed in many creative ways to see which groups had more or less gains. The groups may be defined by gender, education, psychographic and many other characteristics. This will provide invaluable data for other phases of the campaign, for writing proposals to funding agencies, and for others in the field.
- Impact evaluation focuses on long-term impact. It asks questions such as: Was there a reduction in number of people killed?

34.5. Evaluation Plan

Strategic Planning of Outcome Evaluation - Much evaluation that is done may be anecdotal in nature. This is not evaluation in the real sense of the term. Bias may enter in the selection of people who tell anecdotes or in the reporting of anecdotes. Similarly, post-hoc counting of brochures distributed or noting the enthusiasm of people at an activity is not evaluation. Rather rigorous, multi-method (called triangulation) evaluation must be conducted against the communication and action objectives defined earlier in the campaign. This is strategic research as opposed to ad hoc, haphazard evaluation research. Formulate your evaluation plan before the start of the campaign. The plan for your evaluation will depend on the length of your campaign and the resources you have. The plan should detail when (how often, exact time period), where (which sample), and how (which methods) you will conduct the evaluation(s).

For example, if your campaign is one year long and you have necessary resources, you may plan to conduct two concurrent evaluations, one every four months and a post-campaign evaluation. You may randomly pick one or more of several target communities or you may select randomly respondents from each target community as sample. You may decide to conduct a survey and focus groups at each time. You may decide on a panel survey (same sample of people over the three evaluations) or a trend (different sample each time) and on conducting at least four focus groups in each sample community. Critical are the communication and action objectives set earlier. These define what you set out to achieve and therefore measurement of the success of your DRC campaign should be made to demonstrate if these objectives were in fact achieved.

To be able to measure results against the objectives set early in the campaign, before any outcome evaluation is done, baseline data must be collected. To do this, develop a questionnaire based largely on the communication and action objectives of the campaign. That is, the questionnaire must capture

the current (pre-campaign) levels of the effects desired (e.g., knowledge, attitude, Skills and practice levels if these were the targeted effects). Considerable care must be used in developing this questionnaire because it will be used for the concurrent and post-campaign evaluations; questions may be added but the ones already in the questionnaire should not be changed.

34.6. Outcome Evaluation Designs

Generally survey and other qualitative methods such as focus groups, in-depth interviews, target audience diaries, and observation are used in outcome evaluation. Experiments, particularly laboratory experiments, are hard to conduct because of the field nature of DRC campaigns which makes control of rival explanations difficult.

While experiments may be difficult in DRC, field experiments are possible if you can identify a control community that is very similar to your intervention community and has not had any spillover effects from the campaign. That is, the control community must have the same characteristics that your target group has in terms of demographics, psychographics, geographies, KASP levels, etc. (in essence any variable critical to the campaign) and also not have been indirectly exposed to any campaign messages. Here is one possible design:

Intervention Community	Pre-campaign measure	CM 1	CM 2	PCM 1
		PCM2		
Control Community				PCM

Note that if resources require that you make changes in the design of your survey or field experiment, as far as possible do not remove the pre-campaign measure.

34.7. Community Indicators

Such outcome evaluation though can be expensive. Sometimes when resources are very limited, community level indicators may be used (this is not a recommended measure however other than as supplemental to the individual level data). Community level indicators are generally garnered through observation. You may observe if people are learning how to swim or are strengthening homes, how many people are contacting offices for information, whether the media are covering the campaign and the topic of disaster in particular, whether legislative or policy changes are in the making, etc. Even with this kind of data, it is important not to bring in researcher bias in interpretation.

34.8. Steps in Evaluation Research

- Specifically, the steps in your evaluation plan will be:
- Determining the data to be collected based on your communication and action objectives
- Selecting a method(s) to use for the evaluation.
- Designing your data collection instrument

- Collecting and analyzing your data
- Writing a final report

Follow this outline in writing your research report but remember to keep the report user friendly (see attached):

- Introduction: provide the general context within which the DRC campaign has been initiated, elements of the DRC campaign, and its specific communication and action objectives.
- Method: provide details on the method(s) picked (e.g., survey), why; the design picked (e.g., longitudinal), why; the data collection instrument picked (e.g., questionnaire), why; a description of the variables and how they are measured, why; and population and sample, why. Note that these details should be provided both for the outcome and impact evaluations as well as for concurrent and post-campaign evaluations.
- Findings: provide a description of the sample particularly in demographic terms; provide results in terms of KASP and other targeted effects (including attitude to messages, channels used for delivery, etc.). Here you may outline both outcome and impact evaluation results.
- Conclusions: provide a summary of what worked and what did not based on the findings.
- Recommendations: provide recommendations based on these results for others and your own future work.

34.9. Documentation

Monitoring and evaluation are both related to documentation. Documentation is the recording of the experience of project implementation as well as of results of the evaluation. Reasons to document are:

- Provide secondary information to others in the field saving them time and effort
- Provide a proof of performance of your efforts
- Provide materials for display, presentation, academic papers, etc.
- Provide funding agencies with an overview of your capabilities
- Use as a tool to draw in partners, volunteers, etc.
- Use as a tool to boost pride among your staff and others involved in the project
- Use as a tool to send to the media

Staff needs to be socialized in the importance of documentation and trained to contribute to this documentation effort. Together, make a documentation plan so that the effort is not haphazard. Decide what will be recorded in text, pictures, audio and video, at what times within the progress of the campaign and its completion, and who will be responsible for this. This responsibility includes writing reports, clipping newspaper stories and getting taped copies of other press coverage, storing a few copies of all campaign materials, plans, etc., and such.

35. APPENDIX A: MAP OF SRI LANKA WITH 32 COASTAL COMMUNITIES

The Sarvodaya villages marked on the map were selected such that 16 are Sarvodaya 1, 2, & 3 stage communities and the remaining 16 are stage 4 & 5. Table 5 in Technical Annex 4 complies with the set of villages identified on this map.

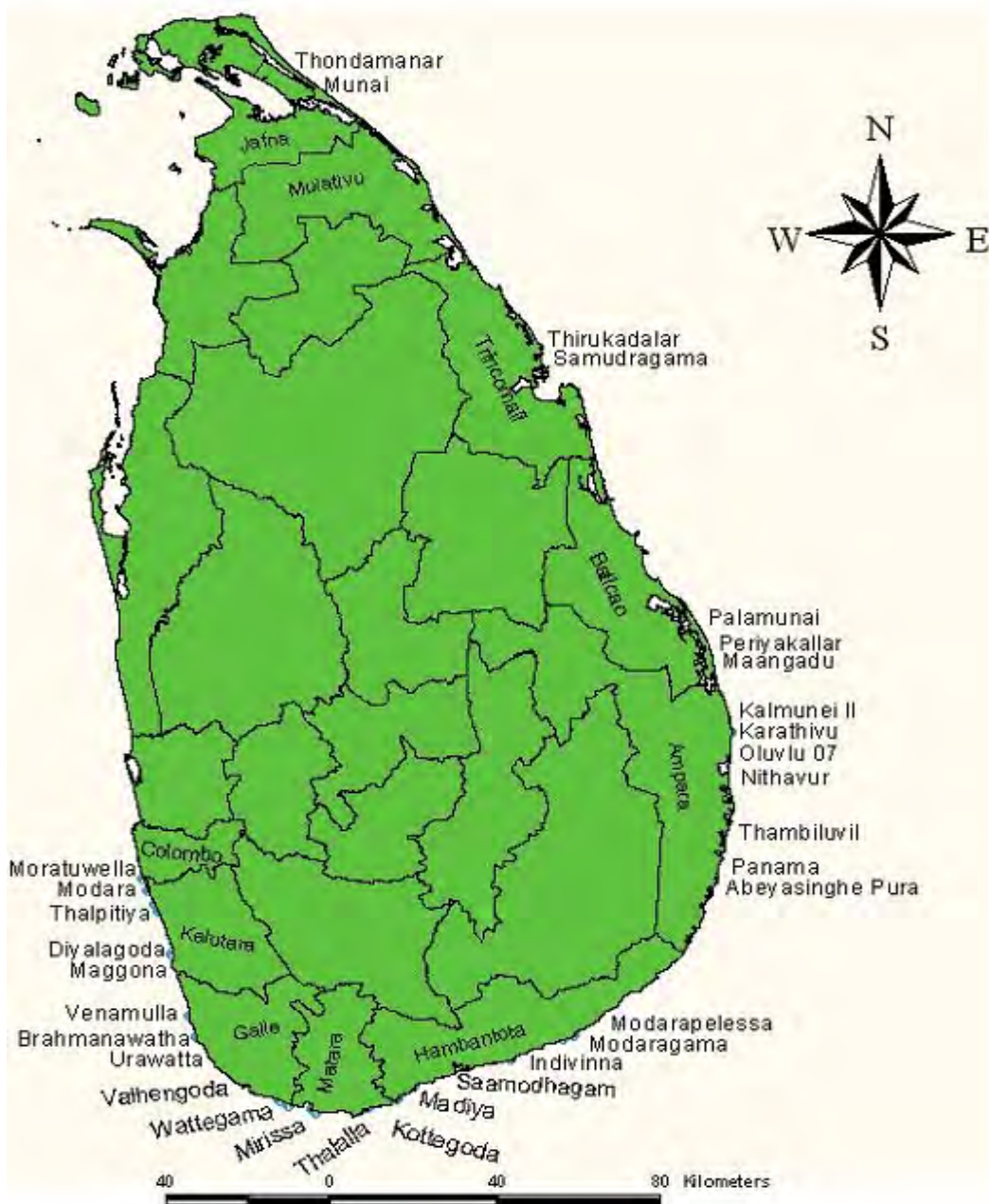

Figure 45 Locations of 32 HazInfo project participating communities.

36. APPENDIX B: DATA OF RESEARCH MATRIX ALLOCATION

Table 43 Allocation of ICTs to Communities with training and organizational capacity

NO	District Name	Community Name	ERP Trained/ Untrained	Development Stage	Committee Name	ICT Name
1	Ampara	Abeysainghepura	Trained	2	None	None
2		Panama North	Trained	4	Sarvodaya shramadana society	AREA
3	Colombo	Modara	Untrained	2	None	None
4		Moratuwella	Trained	2	"SAMUDURA" Sarvodaya S.S	AREA
5	Galle	Brahammanawatta	Untrained	4	Sarvodaya shramadana society	AREA
6		Urawatta	Trained	2	Sarvodaya Center	VSAT
7		Velhengoda	Trained	4	Sarvodaya shramadana society	AREA MOP
8		Venamulla	Untrained	4	Sarvodaya shramadana society	AREA RAD
9	Hambantota	Indivinna	Untrained	4	Sarvodaya shramadana society	FXP
10		Modarapelessa	Trained	2	Sarvodaya shramadana society	AREA RAD
11		Modaragama	Trained	4	Sarvodaya D/C	VSAT
12		Samodhagama	Untrained	4	Sarvodaya shramadana society	MOP
13	Jaffna	Munai	Untrained	2	-	AREA MOP
14		Thondamanar	Untrained	2	Sarvodaya shramadana society	AREA RAD
15	Kalmunai	Kalmunai II	Trained	4	Sarvodaya shramadana society	AREA RAD
16		Ninthavur	Trained	2	Sarvodaya shramadana society	MOP
17		Oluvilu	Untrained	2	Sarvodaya shramadana society	FXP
18		Karathivu	Untrained	2	Sarvodaya shramadana society	AREA FXP
19		Thambiluvil	Untrained	2	Sarvodaya Thambiluvil	MOP
20	Kalutara	Diyalagoda	Trained	4	Sarvodaya shramadana society	MOP
21		Maggona	Untrained	2	Sarvodaya shramadana society	AREA
22		Talpitya	Untrained	4	None	NONE
23	Matara	Kottegoda	Untrained	4	Sarvodaya shramadana society	AREA FXP

24		Madiya	Untrained	2	Sarvodaya D/C	MOP
25		Mirissa South	Trained	4	None	NONE
26		Talalla South	Untrained	4	Sarvodaya shramadana society	AREA MOP
27		Wattegama South	Trained	2	Sarvodaya shramadana society	AREA FXP
28	Trincomalee	Samudragama	Trained	4	Sarvodaya Shanthi Sena	AREA FXP
29		Thirukkadalar	Trained	2	Sarvodaya Trincomalee	FXP
30	Batticaloa	Maangadu	Untrained	4	Sarvodaya Shanthi Sena	MOP
31		Periyakallar	Trained	4	Sarvodaya Shanthi Sena	FXP
32		Palamunai	Trained	2	Sarvodaya Shanthi Sena	AREA MOP

37. APPENDIX C: DATA OF HIH OPERTIONAL

Table 44 live-exercise data for function: Download, Acknowledgment, & EOI completion

NO	Exercise Date	SW Name	Download			Acknowledge			EOI		
			Start	End	Eff	Start	End	Eff	Start	End	Eff
1	11-Dec-06								10:10	10:14	0.95
2	11-Dec-06	ANNY									
3	4-Mar-07	ANNY	10:30	10:31	0.98	10:34	10:34	1.0	10:34	10:36	0.97
4	4-Mar-07	ANNY	10:30	10:31	0.98	10:34	10:34	1.0	10:34	10:36	0.97
5	26-Nov-06	ANNY									
6	26-Nov-06	IPAS									
7	26-Nov-06	ANNY									
	26-Nov-06	DEWN									
8	26-Nov-06	ANNY DEWN									
9		CALL									
10	9-May-07	ANNY	10:16	10:17	0.98	10:17			10:17	10:20	0.96
11	9-May-07	DEWN	10:16	10:17	0.98	10:17			10:17	10:20	0.96
12	9-May-	DEWN	10:16	10:17	0.98	10:17			10:17	10:20	0.96

	07										
13		ANNY DEWN									
14		ANNY DEWN									
15	17-Mar-07	ANNY DEWN	9:06	9:06	1.0	9:06	9:06	1.0	9:06	9:08	0.97
16	17-Mar-07	DEWN	9:06	9:06	1.0	9:06	9:06	1.0	9:06	9:08	0.97
17	17-Mar-07	CALL	9:06	9:06	1.0	9:06	9:06	1.0	9:06	9:08	0.97
18	17-Mar-07	ANNY CALL	9:06	9:06	1.0	9:06	9:06	1.0	9:06	9:08	0.97
19	17-Mar-07	DEWN	9:06	9:06	1.0	9:06	9:06	1.0	9:06	9:08	0.97
20	11-Mar-07	DEWN	10:22	10:22	1.0				10:23		
21	11-Mar-07	ANNY	10:22	10:22	1.0				10:23		
22	9-Apr-06		10:22	10:22	1.0				10:23		
23	11-Dec-06	ANNY CALL							10:10	10:14	0.95
24	25-Feb-07	DEWN							10:10	10:14	0.95
25	11-Dec-06								10:10	10:14	0.95
26	11-Dec-06	ANNY DEWN							10:10	10:14	0.95
27	11-Dec-06	ANNY CALL							10:10	10:14	0.95
28	10-Mar-07	ANNY CALL	10:08	10:08	1.0				10:10	10:11	0.98
29	10-Mar-07	CALL	10:08	10:08	1.0				10:10	10:11	0.98
30	25-Feb-07	DEWN									
31	25-Feb-07	CALL									
32	25-Feb-07	ANNY									

Table 45 Live-exercise data for function: Approval Issue and overall efficiency

NO	Exercise Date	SW Name	Approval			Issue			Exercise Duration	Overall Eff
			Start	End	Eff	Start	End	Eff		
1	11-Dec-06								1:30	
2	11-Dec-06	ANNY				10:36	10:42	93.33%	1:30	93.33%
3	4-Mar-07		10:36	10:39	96.67%				1:30	
4	4-Mar-07	ANNY	10:36	10:39	96.67%	10:39	10:45	93.33%	1:30	93.33%
5	26-Nov-06	ANNY							1:30	
6	26-Nov-06	IPAS							1:30	
7	26-Nov-06	ANNY							1:30	
		DEWN							1:30	
8	26-Nov-06	ANNY							1:30	
9	26-Nov-06	DEWN							1:30	
		CALL							1:15	
10	9-May-07	ANNY	10:20	10:21	98.67%	10:28	10:50	70.67%	1:15	70.67%
									1:15	
11	9-May-07	DEWN	10:20	10:21	98.67%	10:23	10:25	97.33%	1:15	97.33%
12	9-May-07	DEWN	10:20	10:21	98.67%	10:25	10:28	96.00%	1:15	96.00%
13		ANNY								
		DEWN								
14		ANNY								
		DEWN								
15	17-Mar-07	ANNY	9:08	9:10	97.78%	9:10	9:18	91.11%	1:30	91.11%
		DEWN				9:56	9:58	97.78%	1:30	97.78%
16	17-Mar-07	DEWN	9:08	9:10	97.78%				1:30	
17	17-Mar-07	CALL	9:08	9:10	97.78%				1:30	
18	17-Mar-07	ANNY	9:08	9:10	97.78%	9:10	9:18	91.11%	1:30	91.11%
		CALL							1:30	
19	17-Mar-07	DEWN	9:08	9:10	97.78%				1:30	
20	11-Mar-07	DEWN	10:24	10:25	98.89%	10:28	10:32	95.56%	1:30	95.56%
21	11-Mar-07	ANNY	10:24	10:25	98.89%	10:25	10:28	96.67%	1:30	96.67%
22	9-Apr-06		10:24	10:25	98.89%				1:30	
23	11-Dec-06	ANNY				10:36	10:42	93.33%	1:30	93.33%
		CALL				10:55	11:02	92.22%	1:30	92.22%
24	25-Feb-07	DEWN				10:51	10:53	97.78%	1:30	97.78%
25	11-Dec-06								1:30	
26	11-Dec-06	ANNY				10:36	10:42	93.33%	1:30	93.33%
		DEWN				10:51	10:53	97.78%	1:30	97.78%
27	11-Dec-06	ANNY				10:36	10:42	93.33%	1:30	93.33%
		CALL				10:55	11:02	92.22%	1:30	92.22%

28	10-Mar-07	ANNY	10:11	10:15	95.56%	10:15	10:19	95.56%	1:30	95.56%
		CALL	10:11	10:15	95.56%	10:20	10:22	97.78%	1:30	97.78%
29	10-Mar-07	CALL	10:11	10:15	95.56%	10:33	10:34	98.89%	1:30	98.89%
30	25-Feb-07	DEWN							1:30	
31	25-Feb-07	CALL							1:30	
32	25-Feb-07	ANNY							1:30	
		DEWN							1:30	
					Approval			Issue		
					99.1			69.91		

38. APPENDIX D: DATA OF EFFICIENCY MEASURE FROM LIVE-EXERCISES

Table 46 Efficiency data for HIH Monitor and ICT Terminal Devices Pre Community

NO	ICT Name	Exercise Date	HIH Monitor				ICT Terminal Device			
			Sent	Received	Ack	Eff	Sent	Received	Ack	Eff
1	None	12/11/2006	10:19	10:21						
2	AREA	12/11/2006	10:19	10:21		96.67%	10:24	10:24		98.89%
3	None	3/4/2007	10:10	10:35						
4	AREA	3/4/2007	10:10	10:35		83.33%	10:49	10:50		87.78%
5	AREA	11/26/2006	10:25	10:35		87.78%	10:46	10:46		82.22%
6	VSAT	11/26/2006	10:25	10:35						
7	AREA	11/26/2006	10:25	10:35		61.11%	11:10	11:10		100.00%
	MOP		10:25	10:35		83.33%	10:50	10:50		100.00%
8	AREA	11/26/2006	10:25	10:35		87.78%	10:46	10:46		97.78%
	RAD		10:25	10:35		92.22%	10:42	10:42		100.00%
9	FXP		10:25	10:35						
10	AREA	5/9/2007	10:15	10:20		54.67%	10:54	10:54		85.33%
	RAD		10:15	10:20						
11	VSAT	5/9/2007	10:15	10:20						
12	MOP	5/9/2007	10:15	10:20						
13	AREA									
	MOP									
14	AREA									
	RAD									
15	AREA	3/17/2007	9:15	9:16		97.78%	9:18	9:18		97.78%
	RAD		9:15	9:16		92.22%	9:20	9:23		96.67%
16	MOP	3/17/2007	9:15	9:16		88.89%	9:24	9:26		97.78%
17	FXP	3/17/2007	9:15	9:16		88.89%	9:26	9:26		100.00%
18	AREA	3/17/2007	9:15	9:16		97.78%	9:18	9:18		23.33%
	FXP		9:15	9:16						
19	MOP	3/17/2007	9:15	9:16						

20	MOP	3/11/2007	10:15	10:30		77.78%	10:50	10:50		97.78%
21	AREA	3/11/2007	10:15	10:30		97.78%	10:32	10:32		85.56%
22	None	4/9/2006	10:15	10:30						
23	AREA	12/11/2006	10:19	10:21		96.67%	10:24	10:24		98.89%
	FXP		10:19	10:21		84.44%	10:35	10:35		98.89%
24	MOP	2/25/2007	10:19	10:21		87.78%	10:32	10:32		94.44%
25	None	12/11/2006	10:19	10:21						
26	AREA	12/11/2006	10:19	10:21		96.67%	10:24	10:24		98.89%
	MOP		10:19	10:21		87.78%	10:32	10:32		95.56%
27	AREA	12/11/2006	10:19	10:21		96.67%	10:24	10:24		98.89%
	FXP		10:19	10:21		78.89%	10:40	10:40		98.89%
28	AREA	3/10/2007	10:20	10:23		98.89%	10:24	10:24		91.11%
	FXP		10:20	10:23		90.00%	10:32	10:32		100.00%
29	FXP	3/10/2007	10:20	10:23		90.00%	10:32	10:32		98.89%
30	MOP	2/25/2007	10:15	10:18						
31	FXP	2/25/2007	10:15	10:18						
32	AREA	2/25/2007	10:15	10:18		97.78%	10:20	10:20		100.00%
	MOP		10:15	10:18						

Table 47 Efficiency data for ICT Guardian and ERP Coordinator in Community

NO	ICT Name	Exercise Date	ICT Guardian				ERP Coordinator			
			Sent	Eff	Ack	Eff	Sent	Eff	Ack	Eff
1	None	12/11/2006					10:36	10:43		47.78%
2	AREA	12/11/2006	10:24	10:25		86.67%	10:36	10:43		47.78%
3	None	3/4/2007					10:47	10:51		63.33%
4	AREA	3/4/2007	10:50	11:00		94.44%	10:55	10:55		44.44%
5	AREA	11/26/2006	10:46	11:02		82.22%	11:02	11:02		100.00%
6	VSAT	11/26/2006								
7	AREA	11/26/2006	11:10	11:10		97.78%	11:12	11:13		74.44%
	MOP		10:50				11:12	11:13		74.44%
8	AREA	11/26/2006	10:46	10:48		95.56%	10:50	10:55		83.33%
	RAD		10:42	10:42		91.11%	10:50	10:55		83.33%
9	FXP									
10	AREA	5/9/2007	10:55	11:05		80.00%	11:10	11:15		66.67%
	RAD						11:10	11:15		66.67%
11	VSAT	5/9/2007					10:40	10:41		66.67%
12	MOP	5/9/2007					10:40	10:41		66.67%
13	AREA									
	MOP									
14	AREA									
	RAD									
15	AREA	3/17/2007	9:19	9:20		91.11%	9:27	9:30		68.89%
	RAD	3/17/2007					9:27	9:30		68.89%

16	MOP	3/17/2007					10:26	10:29		67.78%
17	FXP	3/17/2007								
18	AREA	3/17/2007	10:26	10:27		96.67%	10:29	10:30		71.11%
	FXP		10:26	10:27		96.67%	10:29	10:30		71.11%
19	MOP	3/17/2007	10:27	10:29		95.56%	10:31	10:32		51.11%
20	MOP	3/11/2007	10:50	10:52		93.33%	10:56	10:58		73.33%
21	AREA	3/11/2007	10:32	10:45		83.33%	10:47	10:55		63.33%
22	None	4/9/2006								
23	AREA	12/11/2006	10:24	10:25		86.67%	10:36	10:40		62.22%
	FXP		10:35	10:36		98.89%	10:36	10:40		62.22%
24	MOP	2/25/2007	10:32	10:37		93.33%	10:38	10:47		58.89%
25	None	12/11/2006					10:50	10:52		68.89%
26	AREA	12/11/2006	10:24	10:25		84.44%	10:38	10:45		53.33%
	MOP		10:35	10:36		96.67%	10:38	10:45		53.33%
27	AREA	12/11/2006	10:24	10:25		96.67%	10:27	10:30		44.44%
	FXP		10:40	10:41		87.78%	10:51	10:53		84.44%
28	AREA	3/10/2007	10:27	10:32		88.89%	10:37	10:39		88.89%
	FXP		10:32	10:32		94.44%	10:37	10:39		88.89%
29	FXP	3/10/2007	10:32	10:33		94.44%	10:37	10:39		88.89%
30	MOP	2/25/2007								
31	FXP	2/25/2007								
32	AREA	2/25/2007	10:20							
	MOP									

Table 48 - Efficiency data summary for all functions in Tables 20 & 21

	ICT	Exercise	Exercise		Hazard		Exercise	
NO	Name	Date	End Time	Duration	Detect	Impact	MTTF	Comments
1	None	12/11/2006	11:23	1:23	10:00	11:30	92%	ICTG Incompetent in documenting msg, Delay in ICTG contacting ERPC
2	AREA	12/11/2006	11:23	1:23	10:00	11:30	92%	ICTG incompetent in documenting msg, Delay in ICTG contacting ERPC
3	None	3/4/2007	11:20	1:20	10:00	11:30	89%	Delay in HIH Monitor retrieving email for details
4	AREA	3/4/2007	11:45	1:45	10:00	11:30	100%	Delay in community

								receiving alert from Modara
5	AREA	11/26/2006	11:02	0:47	10:15	11:45	52%	AREA had 2 bars and didn't receive alert because no FEC, signal strength must be > 4
6	VSAT	11/26/2006	11:45	1:30	10:15	11:45	100%	
7	AREA	11/26/2006	11:35	1:20	10:15	11:45	89%	Did not receive 1st alert, received 2nd,
	MOP		11:35	1:20	10:15	11:45	89%	MOP Received alert but siren not heard by ICTG
8	AREA	11/26/2006	11:05	0:50	10:15	11:45	56%	2nd received AREA alert
	RAD		11:05	0:50	10:15	11:45	56%	1st received RAD alert
9	FXP		11:30	1:15	10:15	11:30	100%	
10	AREA	5/9/2007	11:35	1:20	10:15	11:30	100%	
	RAD		11:35	1:20	10:15	11:30	100%	RAD was sent for repairs and had not received before simulations
11	VSAT	5/9/2007	11:05	0:50	10:15	11:30	67%	
12	MOP	5/9/2007	11:05	0:50	10:15	11:30	67%	RAD was used instead of MOP, could not get applet to work
13	AREA							
	MOP							
14	AREA							
	RAD							
15	AREA	3/17/2007	9:55	0:55	9:00	10:30	61%	Delay in ICT-G receiving message
	RAD	3/17/2007	9:55	0:55	9:00	10:30	61%	Did not receive RAD & No GSM Coverage bc of North-east Conflict, District Coordinator Called with land line
16	MOP	3/17/2007	10:55	1:55	9:00	10:30	100%	No GSM Coverage bc of North East Conflict, District

								Coordinator called via land-line
17	FXP	3/17/2007	10:55	1:55	9:00	10:30	100%	No GSM Coverage bc of North East Conflict, District Coordinator called via land-line
18	AREA	3/17/2007	10:55	1:55	9:00	10:30	100%	Received AREA alert after reassembling the AREA, No GSM Coverage bc of North East Conflict, District Coordinator called via land-line
	FXP		10:55	1:55	9:00	10:30	100%	No GSM Coverage bc of North East Conflict, District Coordinator called via land-line
19	MOP	3/17/2007	11:15	2:15	9:00	10:30	100%	No GSM Coverage bc of North East Conflict, District Coordinator called via land-line
20	MOP	3/11/2007	11:20	1:20	10:00	11:30	89%	Church bell and Mosque speakers announcement not heard by all in community
21	AREA	3/11/2007	11:20	1:20	10:00	11:30	89%	
22	None	4/9/2006	11:30	1:30	10:00	11:30	100%	Thalpitiya was excluded bc live-exercises were run during ToT program as well as by Gov DMC and did not want to exhaust them
23	AREA	12/11/2006	11:10	1:10	10:00	11:30	78%	
	FXP		11:10	1:10	10:00	11:30	78%	
24	MOP	2/25/2007	11:15	1:15	10:00	11:30	83%	
25	None	12/11/2006	11:18	1:18	10:00	11:30	87%	
26	AREA	12/11/2006	11:20	1:20	10:00	11:30	89%	

	MOP		11:20	1:20	10:00	11:30	89%	
27	AREA	12/11/2006	11:17	1:17	10:00	11:30	86%	
	FXP		11:05	1:05	10:00	11:30	72%	
28	AREA	3/10/2007	10:47	0:32	10:15	11:45	36%	
	FXP		10:47	0:32	10:15	11:45	36%	
29	FXP	3/10/2007	10:47	0:32	10:15	11:45	36%	
30	MOP	2/25/2007	11:30	1:30	10:00	11:30	100%	Communities unprepared to conduct live exercises; North-East conflict was a higher priority
31	FXP	2/25/2007	11:30	1:30	10:00	11:30	100%	Communities unprepared to conduct live exercises; North-East conflict was a higher priority
32	AREA	2/25/2007	11:30	1:30	10:00	11:30	100%	Communities unprepared to conduct live exercises; North-East conflict was a higher priority
	MOP		11:30	1:30	10:00	11:30	100%	

39. APPENDIX E: DATA FOR CERTAINTY MEASURE OF ICT

Table 49 Signal strength measured in terms of enumerating bars for each deployment

No	ICT				
	Deployment	Min	Max	Mean	Score
1	None	-	-	-	-
2	AREA	2.00	7.00	4.00	0.88
3	None	-	-	-	
4	AREA	2.00	7.00	4.00	0.88
5	AREA	2.00	7.00	4.00	0.88
6	VSAT	1.00	2.00		
7	AREA+MOP	2.00	7.00	3.50	0.82
		1.00	5.00	3.00	0.88
8	AREA+RAD	2.00	7.00	3.00	0.73
		1.00	5.00	2.00	0.73
9	FXP	2.00	5.00	2.50	0.62

10	AREA+RAD	2.00	7.00	3.50	0.82
11		1.00	5.00	2.00	0.73
12	VSAT	1.00	2.00	2.00	0.73
13	MOP	1.00	5.00	3.00	0.88
14	AREA+MOP	-	-	-	-
		-	-	-	-
15	AREA+RAD	-	-	-	-
		-	-	-	-
16	AREA+RAD	2.00	7.00	4.00	0.88
		1.00	5.00	2.00	0.73
17	MOP	1.00	5.00	2.00	0.73
18	FXP	2.00	5.00	2.00	0.50
19	AREA+FXP	2.00	7.00	3.00	0.73
		2.00	5.00	2.50	0.62
20	MOP	1.00	5.00	2.50	0.82
21	MOP	1.00	5.00	4.00	0.95
22	AREA	2.00	7.00	4.00	0.88
23	None	-	-	-	
24	AREA+FXP	2.00	7.00	4.00	0.88
		1.00	5.00	3.00	0.88
25	MOP	1.00	5.00	4.00	0.95
26	None	-	-	-	
27	AREA+MOP	2.00	7.00	4.00	0.88
		1.00	5.00	3.00	0.88
28	AREA+FXP	2.00	7.00	4.00	0.88
		2.00	5.00	3.00	0.73
29	AREA+FXP	2.00	7.00	4.00	0.88
		2.00	5.00	3.00	0.73
30	MOP	1.00	5.00	3.00	0.88
31	FXP	2.00	5.00	3.00	0.73
32	AREA+MOP	2.00	7.00	3.50	0.82
		1.00	5.00	2.00	0.73

Table 50 Mean certainty for each of the ICT deployments

ICT		
ICT Deployment	Max Score of	Mean Certainty
VSAT		0.73
	0.73	

MOP	0.88	0.87
	0.73	
	0.82	
	0.95	
	0.95	
	0.88	
FXP	0.62	0.65
	0.50	
	0.73	
	0.73	
AREA+RAD	0.73	0.79
	0.82	
	0.73	
	0.88	
AREA+MOP	0.88	0.85
	0.83	
	0.88	
	0.82	
AREA+FXP	0.73	0.84
	0.88	
	0.88	
	0.88	
AREA	0.88	0.88
	0.88	
	0.88	
	0.88	

40. APPENDIX F: EFFECTIVENESS DATA FOR ALL THE CLIQUES

40.1. Full CAP Completeness

Table 51 Description of the ICT capabilities for the Full CAP Completeness set of parameters

<i>Parameter</i>	<i>AREA</i>	<i>MOP</i>	<i>RAD</i>	<i>FXP</i>	<i>VSAT</i>
Ethnicity	Text is only in English; audio channel can carry a voice message in any languages.	MOP has the on-board J2ME applet that can display a SMS text message in all three languages.	Text message in English only. FM radio channel can carry any language but HIH has no control over the commercial FM channels	Voice message in any language	Text message in English only
All-media All-hazards	Text message can carry qualifier elements of the <alert> segment, <urgency>, <severity>, and <certainty> elements. Audio message can carry the <description>	Fixed text indicating “warning” plus limited length of the <description> element	Fixed text indicating “warning” plus limited length of the <description> element	<description> element only	<description> element only
Multimedia	Text and Audio	Text only	Text only	Audio only	Text only

Table 52 Rating for the ICTs for effectiveness of relaying a Complete Full CAP message

<i>Measure</i>	<i>AREA</i>	<i>RAD</i>	<i>MOP</i>	<i>FXP</i>	<i>VSAT</i>	<i>AREA +MOP</i>	<i>AREA +FXP</i>	<i>AREA +RAD</i>
Ethnicity	1.00	0.15	1.00	1.00	0.15	1.00	1.00	1.00
All-media All-hazards	0.95	0.70	0.70	0.80	0.70	0.95	0.95	0.95
Multimedia	0.90	0.50	0.50	0.80	0.50	0.90	0.90	0.90
Rating of Full CAP Completeness	0.86	0.05	0.35	0.64	0.05	0.86	0.86	0.86

40.2. Active Alert Function

Table 53 Description of the ICT capabilities for the Active Alerting set of parameters

<i>Parameter</i>	<i>AREA</i>	<i>MOP</i>	<i>RAD</i>	<i>FXP</i>	<i>VSAT</i>
Accountability	Uses alternate source to acknowledge message	Instantaneous because a return SMS is sent to SMSC when message is viewed by recipient after pressing button	Instantaneous because a return SMS is sent to SMSC when message is viewed by recipient after pressing button	Instantaneous because voice call is real time and recipient is verified	Instantaneous when recipient clicks on received button TCP/IP packet is returned to server
Wakeup	Audible siren on DAMB-R2 and external siren	Audible siren sound on hand held	Audible siren and flashing light	Audible ringing sound	Audible siren sound through computer speakers

Table 54 Rating of ICTs for effectiveness of Alerting the Last-Mile Communities

<i>Measure</i>	<i>AREA</i>	<i>RAD</i>	<i>MOP</i>	<i>FXP</i>	<i>VSAT</i>	<i>AREA+MOP</i>	<i>AREA+FXP</i>	<i>AREA+RAD</i>
Accountability	0.25	1.00	1.00	1.00	1.00	1.00	1.00	1.00
Wakeup	0.87	0.95	0.87	0.85	0.70	0.87	0.87	0.95
Rating of Alerting Functionality	0.22	0.95	0.88	0.85	0.70	0.87	0.87	0.95

40.3. Adoptability

The WorldSpace AREA and Speedcast VSAT systems required that the project invest in some of the infrastructure such as purchasing a dedicated audio channel and installing satellite ground station for the AREA and VSAT respectively. Although Table 14 shows the infrastructure cost these values are not taken in to the calculation of the TCO.

Table 55 Costs associated with each of the ICTs

	<i>Units</i>	<i>AREA</i>	<i>MOP</i>	<i>RAD</i>	<i>FXP</i>	<i>VSAT</i>
Infrastructure Fixed Cost	Cost Per Month	0.00	0.00	0.00	0.00	20833.33
Infrastructure Variable Cost	Cost Per Month	1422000.00	0.00	0.00	0.00	90000.00
Terminal Device Fixed		8000.00	25000.00	15000.00	18000.00	100000.00

Cost						
Terminal Device Variable Cost	Cost Per Month	0.00	0.00	0.00	0.00	0.00
Service Fixed Cost		0.00	1000.00	1000.00	0.00	50000.00
Service Device Variable Cost	Cost Per Month	1000.00	500.00	500.00	500.00	0.00
Number of Active Units	Units	56	12	6	9	2
Total Cost for Terminal Devices	Cost Per Month	44000.00	44000.00	34000.00	36000.00	150000.00

Table 56 Total Cost of Ownership per house hold over three years

	<i>AREA</i>	<i>MOP</i>	<i>RAD</i>	<i>FXP</i>	<i>VSAT</i>	<i>AREA +MOP</i>	<i>AREA +RAD</i>	<i>AREA +FXP</i>
TCO of deployed ICTs for 3 year	44000	44000	34000	36000	150000	88000	78000	80000.00
TCO Per Family for 3 years	440	440	340	360	1500	880	780	800.00
Effectiveness	1.00	1.00	1.00	1.00	0.00	0.79	0.58	0.62

Although the ICT Guardians were expected to document the daily journal it was not carried out. Therefore, data on Integration of ICT in to daily life of the community is based on perception and a few random interviews with the ICT owners. Researchers acknowledge that this data is not substantial evidence.

Table 57 Description of the ICT integration in to daily life of community's perceptions

<i>AREA</i>	<i>MOP</i>	<i>RAD</i>	<i>FXP</i>	<i>VSAT</i>
Enjoyed listening to foreign NEWS channels such as BBC or NDTV as well as the Sarvodaya Talk channel	Monthly bills show usage high during calamities such as when the Northeast conflict broke out in January 2007.	Not used at all negligible use of FM radio.	Monthly bills show usage high during calamities such as when the Northeast conflict broke out in January 2007.	Highly used by HIH for email, internet, and VoIP (Skype)

Table 58 Rating of ICTs for effectiveness of Adoptability

<i>Measure</i>	<i>AREA</i>	<i>RAD</i>	<i>MOP</i>	<i>FXP</i>	<i>VSAT</i>	<i>AREA +MOP</i>	<i>AREA +FXP</i>	<i>AREA+ RAD</i>
Affordability	1.00	1.00	1.00	1.00	0.00	0.78	0.62	0.58
Utilization	0.70	0.10	0.95	0.95	0.95	0.95	0.95	0.70
Rating of Adoptability	0.70	0.10	0.95	0.95	0.00	0.75	0.59	0.41

40.4. Miniaturization

Table 59 Weight of the ICTs in Kg

<i>AREA</i>	<i>MOP</i>	<i>RAD</i>	<i>FXP</i>	<i>VSAT</i>
DAMB-R2, Linear antenna	Nokia 6600	Remote Alarm Device	1xRTT CDMA 2000 telephone	2.4m dish antenna, iDirect modem, and Power unit
0.1680	0.1250	3.6000	0.7500	44.6000

Note – The weight of the AREA+MOP, AREA+RAD, and AREA+FXP is the aggregate of the two units

Table 60 Volume of the ICTs in cubic meters

<i>Dimensions</i>	<i>AREA</i>	<i>MOP</i>	<i>RAD</i>	<i>FXP</i>	<i>VSAT</i>
Length	DAMB-R2: 0.1200 Antenna	0.1086	0.275	0.0168	Modem + Power 0.0508
Width	DAMB-R2: 0.0900	0.0582	0.175	0.0189	Modem + Power 0.2889
Height	DAMB-R2: 0.0250	0.0237	0.0035	0.0077	Modem + Power 0.2413
Volume of Cuboid objects	0.0003	0.0001	0.0017	0.0024	0.0035
Radius	-	-	-	-	0.9000
Volume of Spherical objects	-	-	-	-	1.2724
Aggregated Volume	0.0003	0.0001	0.0017	0.0024	1.2759

Note – The volume of the AREA+MOP, AREA+RAD, and AREA+FXP is the aggregate of the two units

Table 61 Lifetime of Power of ICTs in hours

<i>AREA</i>	<i>MOP</i>	<i>RAD</i>	<i>FXP</i>	<i>VSAT</i>
12v 7A Rechargeable Matrix battery	Nokia 6600 in lithium battery	12v 7A Rechargeable Matrix battery	Inbuilt rechargeable battery	Prolink 0.6Kva Uninterrupted Power Service
8.00	36.00	4.00	8.00	0.5

Note – The lifetime of the AREA+MOP, AREA+RAD, and AREA+FXP is the aggregate of the two units because one unit can be powered down when the other is operational.

Table 62 Rating of ICTs for effectiveness of Miniaturization

<i>Measure</i>	<i>AREA</i>	<i>RAD</i>	<i>MOP</i>	<i>FXP</i>	<i>VSAT</i>	<i>AREA +MOP</i>	<i>AREA +FXP</i>	<i>AREA+ RAD</i>
Weight	1.00	1.00	1.00	1.00	0.29	1.00	1.00	1.00
Volume	1.00	1.00	1.00	1.00	0.10	1.00	1.00	1.00
longevity	0.50	0.25	1.00	0.50	0.03	1.00	0.75	1.00
Rating of Miniaturization	0.50	0.25	1.00	0.50	0.00	1.00	0.75	1.00

40.5. Two-way

Table 63 Bi-directionality of ICTs in terms of upstream and downstream

<i>AREA</i>	<i>MOP</i>	<i>RAD</i>	<i>FXP</i>	<i>VSAT</i>
Downstream only (Broadcast)	Upstream and Downstream	Downstream and Restricted Upstream (Upstream works only after alert has been sent and call back number issued)	Upstream and Downstream	Upstream and Downstream

Table 64 Rating of ICTs for effectiveness of Two-way communication

<i>Measure</i>	<i>AREA</i>	<i>RAD</i>	<i>MOP</i>	<i>FXP</i>	<i>VSAT</i>	<i>AREA +MOP</i>	<i>AREA +FXP</i>	<i>AREA+ RAD</i>
Rating of Two-way	0.00	0.70	1.00	1.00	1.00	1.00	1.00	0.70

41. APPENDIX G: OUTCOME OF THE ICT IN THE FIELD

41.1. WorldSpace Addressable Satellite Radio System

Reliability of transmitting CAP Messages

Initial test results show all devices to take less than 7.2 seconds to push the alert messages to the end user AREA devices. The signal path for the alert message is from the Toulouse server to the Singapore BOC, interfacing with the BC-LAN and inserting the binary coded CAP message into the OAAC channel (BCID 2000) for decoding by the DAMB-R2. As DAMB-R2 was able to receive and interpret the alert message, it appears that the CAP coding, binary conversion, routing to the correct port in Singapore are happening correctly.

In terms of certainty there was no issue in receiving the minimum signal strength 4 of 7 bars to receive text and audio alerts. The WS worked without fail in all of the coastal community live-exercises, except for one case when the antenna was not properly aligned for minimum required signal strength. There was a situation where the CDMA and GSM terrestrial public networks work instructed to be turned off by the Government of Sri Lanka in the North-East conflict areas during military operations. However, the satellite based one-way system was operational and was able to transmit alerts during the field trials in these conflict areas. The average certainty of the WS AREA devices ranked to be 0.88 based on the average signal strength at each of the measuring points in the communities.

Efficiency as a function of time was measured from the instant the HIH staff created and issued the CAP message through the ANNY Networks to the moment the message was received, decoded, and recorded by the ICT-G in the community. In order to receive the text of all the elements, due to the limited 80 character display, the user has to press one of the control buttons of the terminal device to jump to the next text element. This step-by-step operation of scrolling and recording the text message took 2 - 3 minutes. The HIH staff would spend 7 – 12 minutes, depending on the length of the message to record the audio and upload to the server. Thereafter, the message would be queued broadcasted within a few seconds. The WS system for the first set of live-exercises, with respect to a tsunami alert anticipating a 90 minute period, ranked to have an efficiency of 0.87.

Effectiveness of the ‘Terminal Device

CAP Complete -- The WS additional ‘External Box’ could display the entire CAP message. The ‘External Box’ was not tested in the field (i.e. in the communities). The DAMB-R2 tested in the field could display the CAP elements: *<msgType>*, *<scope>*, *<sender>*, *<status>*, *<category>*, *<urgency>*, *<severity>*, *<certainty>*, and *<event>*. These elements were adequate to provide the ICT-G with the type of hazard and the priority level but inadequate to carry a complete alert bulletin with full instructions. However, the audio message is capable of carrying the *<description>* element of the CAP message. Both the text and audio components together form the mandatory elements of the CAP Profile for Sri Lanka; as a result score a 0.95 on the ability to carry the necessary and sufficient elements of a CAP message. The English text messages received in the rural English illiterate communities were ineffective. Hence, an alternative was when issuing an alert using the ANNY

Network the HIH staff would instruct the interface to auto switch the audio channel of the DAMB-R2 to the SarvoTalk (BCID 950) channel. Thereafter, the HIH staff would record and upload an audio (voiced) version of the <description> element of the CAP message, which would carry the complete bulletin in the three national languages: Sinhala, Tamil, and English. The scoring method also emphasised that the ICT be capable of transmit both audio and text, which gave the AREA a 0.95 score for CAP Compliant (i.e. being CAP Complete).

Two-way – The WS systems being a one-to-multi-point system would score an absolute zero in terms of effectiveness because the research emphasised the importance of tow-way communication in warning systems. Therefore, the research had coupled the AREA units with an alternate two-way device such as a GSM mobile phone or CDMA normadic phone. The ICT-G would use the mobile phone or the normadic phone to communicate with the HIH to notify them of any local hazards (upstream communication), which was not possible using the AREA units. This marriage would increase the effectiveness score in terms of two-way of the AREA with mobile phone or AREA with normadic phone to 0.85.

Adoptability – Total cost of ownership and integration of the system into the community daily life measures the adoptability of the system. The cost of an AREA terminal device is well under USD 80. However, the audio channel is what costs the most. Currently the HazInfo project is paying for the audio channel. Sarvodaya being present in 15,000 villages in Sri Lanka can make it affordable to the communities once the system is implemented in all those villages at which point the per user cost for the Channel subscription fee will be affordable. One belief in the world of ‘public alerting’ is that the best alerting device is the one that is ‘on’ and is ‘used’ all the time. The content for SarvoTalk (BCID 950) is developed by Sarvodaya. The channel is operational around-the-clock where Sarvodaya broadcasts community-development based content to its member communities. There are a dozen trained youth scattered in the coastal districts. They record content on to simple MP3 player/recorders and email the files or deliver the files burned on CDs to the HIH. The HIH has employed a Media Assistant who edits the content received from the communities and uploads on to the WS SarvoTalk channel. Besides normal weekly programs the HIH also captures special events conducted by Sarvodaya such as workshops and community events that are later broadcast to the communities, which keeps the channel alive.

Miniaturization – The idea of the LM-HWS was to use the system during pre and post disasters; where one aspect of the system is to provide alerts with adequate time for the communities to execute their ERPs to protect themselves from the hazards and the second aspect is after the disaster when the community livelihoods are destroyed the system must would communicate with the community during response and recovery stages. Therefore, the terminal devices must be portable. The research assessed Miniaturization in terms of the longevity of DC power consumption, volume of the complete terminal device, and weight of the terminal device (including antenna and battery). The WS AREA-B system can run on a 12v battery that weighs less than 3kg for 8 hours comfortably. The battery can be recharged using a solar panel. The rating for the AREA unit (excluding the solar panel) based on the fact that the unit must function consecutively for at least 30 hours, must weigh less than 30kg (for a single person to carry comfortably), and has a volume that fits in a small suitcase or backpack, scored 0.68. The score improves to 0.95 when the portable solar panel is included in to the rating, which assumes DC power is available for 18 hours (assuming 10 hours powered by solar panel during day time and 8 hours of battery power during night time).

Alerting – This is an effectiveness feature equally important as CAP Completeness. The parameters: *Active Alert Function* and *Message Receipt Acknowledgement* are what determine the Alerting effectiveness. The message receipt acknowledgement is different from Two-way or upstream communication. This function is important for the message ‘recipients’ to notify the message ‘sender’ the receipt of message [8]. Since WS uses *forward-error-correction* encryption and decryption for audio and text packets it is almost impossible for the ICT-G to receive a mutated or truncated message, provided the uplink and satellite doesn’t fail during transmission. The ICT-G would use the spouse terminal device married to the AREA such as the GSM mobile phone or CDMA nomadic phone to acknowledge message receipt. During a crisis situation both the GSM and CDMA networks get congested and the acknowledgement would be delayed. Unlike an SMS controller that would receive a return message upon the user accepting the SMS the WS system does not have a message returned to the server, which the HIH staff could query to check if the messages have been delivered to the end user. Active Alert Function describes the basis of being able to get the attention of the ICT-G. The AREA units have an audible alarm. The research ranks an audible siren higher over a flashing light or a vibration which must be in visible range or attached the ICT-G respectively [8]. Although the AREA has the ability to ‘wakeup’ (or get the attention) of the ICT-G, it is weak in the message receipt acknowledgement as it must rely on an alternate system. Therefore, the overall effectiveness for Alerting scores a 0.22.

41.2. Dialog Disaster and Emergency Warning System

Uncertainty and Inefficiencies in Messaging

The terminal device reliability measures: certainty and efficiency were recorded on the day of the live-exercises. The results in Fig. 5 are a summary (average) of the measures obtained during each of the exercises conducted in the individual communities.

Certainty in the RAD devices dropped below a benchmark of 0.85 because the signal strength in location of the devices measured between 2 – 3 bars. However, this did not effect the SMS alert coming through because 1 bar was sufficient to receive the alerts and activate the alerting operational states of the device. The research experienced cases of 0 (zero) certainty due to unquantifiable reasons where the community ICT-G had accidentally deleted the J2ME applet, had forgotten to charge the battery of the MOP, had not paid the phone bill, communities in the North and East conflict areas of Sri Lanka being denied GSM access because the Government of Sri Lanka was conducting military operations and had instructed the mobile operators turn of the cells in those conflict areas.

In some communities the alert message was not received during the first attempt of pushing the messages to the MOPs using the DEWN Internet application. Therefore, the efficiency dropped as a result of excess time taken to repeat the process in order for the MOPs to receive the alerts.

Normally both GSM devices take less than 30 seconds to push the alert messages to the end user devices. No more that 1 – 3 units were used during any given trial. Therefore the trials were not effected by congestion even though both solutions use a store-and-forward method to push the SMS

alerts to each device. Ten MOPs were tested in the different communities. Hence, the additional samples used in the trials compared to the 2 RAD units used the research had the opportunity to learn lessons of unsuccessful behaviors. The MOPs tested in the rural environments, where the ICT incompetence of the ICT-G in the communities using non traditional feature introduced by inserting a J2ME applet, for example, further effected to the efficiencies because the menu and instructions were in English, incomprehensible by folks in the rural areas. The RAD score a high rating in terms efficiency because only 2 units were used in the field trials and they both happened to performed quite well in the urban environment. The distinctly marked 4 buttons in he RAD opposed to the menu driven MOP simplified the transition between operating states to increase efficiencies.

Effectiveness of Alerting the ICT-G

Both units, the RAD and MOP, have good active alerting capabilities because they both have audible sirens and a flashing light. The MOP can be weak at times when the device is concealed in a trouser pocket or is detached from the ICT-G at a distance; where both the audible siren and light may not be strong enough to get immediate attention of the ICT-G. However, the RAD is the most effective unit of all the ICTs tested. The RAD would gain the immediate attention of the ICT-G as a result of the loud siren and externally mounted large orange light even from a distance of 50 meters.

Of the two units the MOP has the best Miniaturization features; where the ICT-G can carry the MOP, weighing less than 200 grams (Nokia 6600 weighs 130 grams), in an external belt-case or the pocket, which also frees their hands. Comparitively, the weight and size of the RAD requires a single person to carry the unit by its fixed handle or, as an alternative, carry the RAD in a backpack. The RAD works both on AC and DC power. However, the 12v battery that provides the power to the unit had approximately 4 hours or less of a life time, when the unit went through all the operational sates in receiving multiplicity of repeated alerts . Unlike the MOP, which is quite versatile, the RAD does not provide utilities other than the FM radio and for alerting for the average citizen to use in their daily lives. The initial design of the units were for Government First-Responders; where the sets telephony feature of the unit was denied. Therefore, the community users were not able to use the unit to make voice calls or send SMS as an when they wanted, restricting upstream communication. The voice call was active as a ‘call-back” feature only following the receipt of and alert; where the user would press a button to call back a central information source at a pre programmed phone number. The restriction in two-way communication in the RAD ranked very low compared to the MOP, which was unrestricted. In regards to CAP Completeness, ony the MOP was capable of receiving messages in the three languages: Sinahala, Tamil, and English. The RAD was capable of receiving Englishe text messages.

Shortcomings of the ICTs with the use of CAP

The 2 GSM ICTs used in the project make use of the CAP message format. As illustrated in Table 3, each is only capable of displaying a limited number of the CAP elements, limiting the amount of alert message content that can be transmitted to the ICT-G. Consequently, during simulations, ICT-G recorded only the *<msgType>* and a truncated portion of the *<description>* elements because that’s all they received. Although, the RAD and MOP devices use the *<description>* element that could have carried a complete set of information, they were restricted to an overall message content limit of 270

characters, which is insufficient to carry a meaningful unambiguous alert message. Message did not include *<urgency>*, *<severity>*, and *<certainty>* to enable ICT-Guardians to judge the *Priority* of the incident, which is mandatory for the CAP Profile for Sri Lanka. Therefore, both devices were only good for getting the attention of the ICT-G that there was an eminent threat but were forced to seek complete information from an alternate source.

EXAMPLE 1: The simulations began at the HIH with the receipt of an email containing the critical information pertaining to a Cyclone hazard. The following abstract of the entire message contains the critical information of the message.

“A SEVERE CATEGORY 4 CYCLONE is now current for HAMBANTOTA District coastal areas. At 10:00 am local time SEVERE TROPICAL CYCLONE MONTY was estimated to be 80 kilometers west of Hambantota and moving southeast at 10 kilometers per hour.”

The HIH then transformed message to a CAP Message and entered the relevant information in to the DEWN HTTP application. The *<msgType>* was set to “Warning” and the Cyclone message was inserted in to the *<description>* field. The Cyclone message was translated to Sinhala and Tamil languages to be used; especially with the MOP.

Table 3 illustrates the elements of the CAP message received and parts of the message received by each of the devices. The RAD provided more information than the MOP but no a full message where it was truncated after 160 characters. The MOP displayed that there was a Cyclone warning in effect but had no additional information as to where and when the hazard is effective.

Table 65 Messages received by the RAD and MOP

<i>RAD</i>	<i>MOP</i>
“Warning A SEVERE CATEGORY 4 CYCLONE is now current for HAMBANTOTA District coastal areas. At 10:00 am local time SEVERE TROPICAL CYCLONE MONTY was estimated to be 80 kilometers west of Hamban”	“Warning” “A SEVERE CATEGORY 4 CYCLONE” “ {same in Sinhala}” “ {same in Tamil”

41.3. Solana Networks/Innovative Technologies VSAT/IPAS

Reliability of the VSAT/IPAS

In tests performed with IPAS, the message system appears to be very efficient and straightforward for composing and sending alerts. However, certain peculiarities were observed that will be important for both HIH Monitor message senders and ICT Guardian receivers to take note of.

If the Internet connection is broken, the client may lose its subscription record and thus its

configuration for receiving alerts. When this occurs, the client still appears to the user to be functioning correctly in its standby mode, but will not be triggered by an alert message until it is closed and restarted. At that point, its subscription record is reloaded and the client will function correctly again.

However, even VSAT systems are not entirely risk free. Several factors can affect continuity of services. First, the earth stations must be perfectly aligned with the geostationary satellite and any small movement of the station can easily cause loss of signal. This can be problematic during severe weather events such as cyclones, requiring skilled technicians to realign dishes and restore services. Also, even when the satellite component of the network is functioning perfectly, loss of connectivity from the gateway to the Internet can also disrupt connectivity for accessing the IPAS server or clients. Such as the situation that occurred on 27 December 2006 when an earthquake in the Taiwan region severed the undersea fiber network connecting the Hong Kong Gateway to Europe and beyond. Further, any failure of equipment at the HIH or village nodes will cause message delivery failures. Two potential recurring issues are power loss and affects of heat on satellite modems.

With the installation of the VSAT gateway at the HIH, two separate routes are now available to improve redundancy and diversity in routing to the IPAS server located in Canada. One route (Dialog) uses a domestic gateway to connect overseas with the return link for alerts traveling over the VSAT stations fed through a gateway in Hong Kong. The second route uses the Hong Kong gateway to connect the HIH to the Internet (in Hong Kong) and then is routed to the IPAS server whereupon the return path from the server is uplinked to HIH and the VSAT equipped villages via the Hong Kong gateway. In this latter case, the IPAS system can operate completely independently of the Sri Lankan domestic networks and adds another potential layer of disaster resiliency.

Effectiveness of the System

Because IPAS, in its current form, is not CAP-compliant, it has not been tested for CAP interoperability like the DEWN and ANNY applications, where a CAP message sent from the WorldSpace ANNY application is teleported to the Dialog-Microimage DEWN application and, thereafter, the DEWN application uploads the same message for dissemination. One advantage of IPAS is that unlike SMS and the basic AREA DAMB-R2 components, IPAS appears capable of carrying the equivalent of the entire CAP description field. IPAS alerts can also be received on any Internet enabled MS Windows computer and is not dependent on a dedicated network. However, IPAS currently only supports English language text messaging and cannot support Sinhala or Tami scripts in either the Server GUI for message creation or Client GUI for message display.

The HIH depended exclusively upon a Dialog 128 kbps fixed terrestrial wireless link (bridge) for its Internet access.¹³ This connection is terminated at the HIH through a modem which in turn is connected to a Local Area Network (LAN) through a data switch and a wireless 802.11g WiFi access point. Dialog provides 5 static IP addresses for use at the HIH.

Before the VSAT facilities were operational, this fixed wireless link was used to test the IPAS server-

¹³ The Dialog connection is now replaced by the VSAT satellite connection and now serves as the backup connection.

to-client connection and to enable the HIH staff to become familiar with IPAS message composition and dissemination. However, during this period, a series of problems concerning outbound Internet connectivity emerged and continued to plague the tests, resulting in both the software timing out before messages could be fully entered into their templates and/or sent. These problems manifested themselves in the form of severe network congestion that caused lengthy delays in logging into the servers. After an extensive investigation, it was revealed that four separate issues were at the root of the problems.

The first problem was caused by an incorrectly connected cable that was routing data packets from the WiFi access point router back into the main Dialog connection. This effectively caused the LAN to be flooded with excess packets, causing severe local congestion. Once correctly cabled, most of the congestion disappeared.

The second problem was caused by the HIH workstations being connected to the WiFi access point, rather than through a cable connection to the Dialog router via the data switch. The WiFi access point appears to intermittently drop its signal, causing the link to time out and PCs to have to reinitialize their Internet connections through a DHCP setup. Each time this occurred, the connection to the IPAS servers broke and/or timed out. This problem was solved by connecting the PCs directly to the Dialog connection and assigning them a Dialog static IP address.

The third problem was caused by congestion on the main Dialog backbone connection. This was discovered by conducting a trace route connection between the HIH and the final destination where the server resided; in the case of IPAS, the server resides Canada. A trace route test sends a series of data packets through the network and measures and analyzes the quality of the link according to how long it takes to get an acknowledgement back from all of the locations where the packets are routed on their way to the final destination (latency), along with how many of the sent packets were dropped in transit (packet loss). The trace route tests revealed that, at times, there were significant latencies in packet delivery possibly due to congestion or a malfunctioning router at the Dialog gateway, which were resulting in timeouts and excessive packet losses en route to their final destination. Results of the route traces were sent to Dialog who, in turn, made changes to the packet routing. The routing now appears to be stable.

The fourth problem was caused by the Dialog radio antenna being mounted on a tall pipe that tends to sway in the wind, moving the antenna in and out of focus.

Power outages and lightning storms -- VSATs and PCs require an alternative power source during power interruptions. Presently, neither the HIH nor the ICT Guardians possess alternative backup power to mitigate the impacts of frequent or prolonged power interruptions. Often, to prevent power surges, equipment is unplugged during lightning storms.

Further in order to keep satellite modems functioning properly they must be protected from excess heat and require proper ventilation and some form of air conditioning. Even accidentally covering the ventilation holes on the modem's cover can cause equipment malfunctions.

42. APPENDIX H – DATA FROM SILENT TESTS

Table 66 Silent test results 06 to 10 August 2007

<i>No</i>	<i>Date</i>	<i>Time</i>	<i>Village</i>	<i>Device No.</i>	<i>ICT</i>	<i>Status</i>	<i>Remarks</i>
1			Moratuwa	602164957	FXP	Working	
2	06.08.2007	12.03PM	Thirukkadalar	602269982	FXP	Working	Line is Not Clear
3	06.08.2007	12.07PM	Oluvil	602679957	FXP	Working	
4	10.08.2007	9.23AM	Samudragama	602269981	FXP	Not working	Phone is Currently Not Available
5	10.08.2007	9.26AM	Shitthandikudipuram	602659950	FXP	Not working	Phone is Currently Not Available
6	06.08.2007	1.10PM	Waththegama	602418972	FXP	Working	
7	06.08.2007	12.50PM	Kottegoda	602418973	FXP	Not working	Ringing NO Answer
8	06.08.2007	12.54PM	Idivinna	602489978	FXP	working	
9			Periyakallar	602659955	FXP	Not working	
10			Oluvil	602679957	FXP	Working	Now the Line is Clear
11	07.08.2007	10.08AM	Palmunnai	773428477	MOP	Working	
12	06.08.2007	4.28PM	Welhengoda	773428478	MOP	Working	
13	10.08.2007	3.42PM	Thalalla South	773428479	MOP	Working	DEWN software is not working
14	10.08.2007	3.37PM	Meddewatte	773428480	MOP	Working	
15	06.08.2007	4.38PM	Saturkondan	773428481	MOP	Not working	Line is Disconnected
16	06.08.2007	2.22PM	Diyalagoda	773428482	MOP	Working	
17	10.08.2007	3.22PM	Thambiluvil	773428483	MOP	Working	
18	10.08.2007	3.45Pm	Niluka Wicramasinhge	773428484	MOP	Working	
19	06.08.2007	4.25PM	Nindaur	773428485	MOP	Working	
20	07.08.2007	10.23AM	HUB Disconnected	773428486	MOP	Not working	Line is Temporally Disconnected
21	07.08.2007	3.01PM	Samodagama	773428487	MOP	Working	DEWN Software is Uninstalled
22			Rajiw	773428488	MOP	Working	
23			Moratuwella	10000000 00068845	AREA		

24			Maggona	10000000 00068841	AREA		
25	07.08.2007	4.10PM	Palamunai	10000000 00068842	AREA		
26	07.08.2007	4.22PM	Warregama South	10000000 00068840	AREA		
27			Brahmanawatta	10000000 00068847	AREA		
28			Kalmunai II	10000000 00068849	AREA		
29	06.08.2007	4.28PM	Wellhengoda	10000000 00068848	AREA		
30			Susiripala	10000000 00068843	AREA		
31			Talalla South	10000000 00068844	AREA		
32			Wennamulla	10000000 00068800	AREA		
33			Panama North	10000000 00068805	AREA		
34			Sithandikudipuram	10000000 00068801	AREA		
35			Modara Pelessa	10000000 00068806	AREA		
36			Munnai	10000000 00068802	AREA		
37			Tondamanaru	10000000 00068807	AREA		

Table 67 Silent test results 15 to 20 October 2007

No	Date	Time	Village	Device No	ICT	Status	Remarks
1	16.10.2007	9.10AM	Moratuwa	602164957	FXP	Working	Some times it is not clear
2	16.10.2007	9.22AM	Thirukkadalar	602269982	FXP	Working	
3	16.10.2007	9.25AM	Oluvil	602679957	FXP	Working	
4	16.10.2007	9.26Am	Samudragama	602269981	FXP	Not working	could not do the silent test because phone is not contactable
5	16.10.2007	9.34AM	Shithtandikudipuram	602659950	FXP	Not working	Could not do the Silent test because the phone is Power off
6	18.10.2007	9.46AM	Waththegama	602418972	FXP	Not working	Could not do the silent test because phone is not reachable
7	17.10.2007	9.51AM	Kottegoda	602418973	FXP	Not working	Could not do the silent test because phone is not contactable
8	18.10.2007	9.55AM	Idivinna	602489978	FXP	Working	
9	17.10.2007	10.04AM	Periyakallar	602659955	FXP	Ringing	Phone is Ringing but no answer
10	17.10.2007	0	Palmunnai	773428477	MOP	Working	
11	16.10.2007	10.04Am	Welhengoda	773428478	MOP	Working	AREA is working but could not do the silent test because the person is on the way to Sarvodaya Head office
12	20.10.2007	4.28Pm	Thalalla South	773428479	MOP	Working	DEWN software is not working
13	20.10.2007	3.42PM	Meddewatte	773428480	MOP	Working	
14	16.10.2007	3.37PM	Saturkondan	773428481	MOP	Not working	Line is Disconnected
15	16.10.2007	4.38PM	Diyalagoda	773428482	MOP	Working	
16	20.10.2007	2.22PM	Thambiluvil	773428483	MOP	Working	
17	20.10.2007	3.22PM	Niluka Wicramasinhge	773428484	MOP	Working	
18	16.10.2007	3.45PM	Nindaur	773428485	MOP	Working	
19	17.10.2007	4.26PM	HUB	773428486	MOP	Not working	Phone is Temporally Disconnected
20	17.10.2007	10.23AM	Samodagama	773428487	MOP	Working	DEWN Software is Uninstalled
21	18.10.2017	10.30AM	Rajiw	773428488	MOP	Working	

22	15.10.2007	11.10Am	Moratuwella	10000000 00068845	AREA	-	The ICT person's all of contact lines are not working. Could not do the silent test
23	15.10.2007	11.35Am	Maggona	10000000 00068841	AREA	-	Could not do the silent test because it is a Religion problem she is handed over the AREA Device to Temple through the Sarvodaya District Center. Have no any contact details of the temple persons.
24	15.10.2007	11.42AM	Palamunai	10000000 00068842	AREA	-	The ICT person's all of contact lines are not working. Could not do the silent test
25	18.10.2007	9.46AM	Warregama South	10000000 00068840	AREA	-	The ICT person's all of contact lines are not working .Could not do the silent test
26	18.10.2007	10.01AM	Brahmanawatta	10000000 00068847	AREA	-	The Power charger is not inside. After the rapier the power charger is misplaced
27	18.10.2007	10.11AM	Kalmunai II	10000000 00068849	AREA	-	could Not contact to person
27	18.10.2007	10.15Am	Wellhengoda	10000000 00068848	AREA	Working	
29	18.10.2007	10.17AM	Susiripala	10000000 00068843	AREA	-	The ICT person's all of contact lines are not working. Could not do the silent test
30	18.10.2007	10.20Am	Talalla South	10000000 00068844	AREA	Working	Some times it is not working
31	18.10.2007	10.49Am	Wennamulla	10000000 00068800	AREA	-	The ICT person's all of contact lines are not working. Could not do the silent test
32	18.10.2007	11.07AM	Panama North	10000000	AREA	-	The ICT person's all of contact

				00068805			lines are not working. Could not do the silent test
33	18.102007	11.10Am	Sithandikudipuram	10000000 00068801	AREA	-	The ICT person's all of contact lines are not working. Could not do the silent test
34	18.102007	11.18Am	Modara Pelessa	10000000 00068806	AREA	-	The ICT person's all of contact lines are not working. Could not do the silent test
34	-	-	Munnai	10000000 00068802	AREA	-	
36	-	-	Tondamanaru	10000000 00068807	AREA	-	

Table 68 Silent test results 26 to 30 December 2007

No	Date	Time	Village	Device No	ICT	Status	Remarks
1	26.12.2007	11.16AM	Moratuwa	602164957	FXP	Working	
2	26.12.2007	11.32AM	Thirukkadalar	602269982	FXP	Working	
3	26.12.2007	11.38AM	Oluvil	602679957	FXP	Working	
4	26.12.2007	11.38.AM	Samudragama	602269981	FXP	Not working	Power OFF ; could not do the silent test because phone is Power Off
5	26.12.2007	11.40AM	Shitthandikudipuram	602659950	FXP	Not working	Power OFF ; Could not do the Silent test because the phone is Power off
6	26.12.2007	12.00.PM	Waththegama	602418972	FXP	Not working	Power OFF ; Could not do the silent test because phone is not reachable
7	26.12.2007	11.48AM	Kottegoda	602418973	FXP	Not working	Could not do the silent test because phone is not contactable
8	26.12.2007	11.45AM	Idivinna	602489978	FXP	Working	
9	26.12.2007	11.42AM	Periyakallar	602659955	FXP	Ringling	No answer

10	26.12.2007	11.46AM	Palmunnai	773428477	MOP	Working	
11	26.12.2007	12.25PM	Welhengoda	773428478	MOP	Working	
12	26.12.2007	1.03PM	Thalalla South	773428479	MOP	Working	
13	26.12.2007	1.06PM	Saturkondan	773428481	MOP	Not working	Line is Disconnected
14	26.12.2007	1.07PM	Diyalagoda	773428482	MOP	Ringling	Not Responded
15	26.12.2007	1.08PM	Thambiluvil	773428483	MOP	Not working	Out of Service; disconnected
16	26.12.2007	11.17AM	Niluka Wicramasinhge	773428484	MOP	Working	
17	26.12.2007	1.25PM	Nindaur	773428485	MOP	Working	
18	26.12.2007	11.18AM	HUB Disconnected	773428486	MOP	Not working	Phone line is Disconnected
19	26.12.2007	11.18AM	Rajiw	773428488	MOP	Working	
20	30.12.2007	9.48Am	Moratuwella	10000000 00068845	AREA	Not working	The ICT person's all of contact lines are not working. Could not do the silent test
21	30.12.2007	9.49AM	Maggona	10000000 00068841	AREA	Not working	The ICT Person's Contact line is can not be reach
22	30.12.2007	9.50Am	Palamunai	10000000 00068842	AREA	working	The ICT person's all of contact lines are not working. Could not do the silent test
23	30.12.2007	12.25PM	Warregama South	10000000 00068840	AREA	Ringling	The ICT person's all of contact lines are not working .Could not do the silent test
24	26.12.2007		Brahmanawatta	10000000 00068847	AREA	Other Problem	The Power charger is not available. After the repair MOP the power charger is misplaced
25		12.25PM	Kalmunai II	10000000 00068849	AREA	-	could Not contact to person
26	30.12.2007	12.27PM	Wellhengoda	10000000 00068848	AREA	Working	
27	30.12.2007	1.03PM	Susiripala	10000000 00068843	AREA	-	The ICT person's all of contact lines are not working. Could not do the silent test

28	26.12.2007	1.06PM	Talalla South	10000000 00068844	AREA	Working	Some times the signal is problem
29	26.12.2007	9.51Pm	Wennamulla	10000000 00068800	AREA	-	The ICT person's all of contact lines are not working. Could not do the silent test
30	30.12.2007	9.53PM	Panama North	10000000 00068805	AREA	-	Could Not contact the person; The ICT person's all of contact lines are not working. Could not do the silent test
31	30.12.2007	9.54PM	Sithandikudipuram	10000000 00068801	AREA	-	Can not contact the person; The ICT person's all of contact line are switch off
32	30.12.2007	12.01PM	Modara Pelessa	10000000 00068806	AREA	-	Power off; The ICT Guidant Is no at the home. Spoke with his wife she said that the Device is not connect t the Power.
33	-		Munnai	10000000 00068802	AREA	-	-
34	-		Tondamanaru	10000000 00068807	AREA	-	-

43. APPENDIX I – OUTCOME OF ICT ON 12-SEP-2007 TSUNAMI ADVISORY

Table 69 Email from Executive Director of Sarvodaya on Tsunami Watch 12-Sep-2007

Dear All,

It was quite an interesting learning experience how the country (Sri Lanka) reacted to yesterday's Tsunami warning following the earthquake in Indonesia yesterday and also the present alert following another quake around 5.30 a.m. this morning.

Sarvodaya Community Disaster Management Centre (SCDMC) went into immediate action and we were able to test "live" all our systems including the landlines, mobile phones and especially the addressable satellite radio (ASR). After the official Tsunami warning was given we prepared and sent regular alerts and updates to the Last Mile Project (IDRC supported) villages as well as the Sarvodaya District Centers in the coastal belt. We are receiving now reports of how effectively the messages were received.

We were also able to identify weaknesses in our own systems at the Emergency Operations Centre (EOC) of SCDMC and today as I write this another Tsunami warning has been given and we are working on these weaknesses.

We have also witnessed how much the national disaster warning system has to improve in terms of standard protocols etc. There was wide spread panic and uncoordinated response.

This is only an initial update for our partners and a detailed report will be submitted towards this evening.

Regards,

Vinya

Table 70 Performs of Mobile Phones on the real event of a Tsunami watch on 12-Sep-2007

0	ICT G Name	Tel No	Message Status	Remarks
1	Hewawitharana	773428480	Not Received	Software Problem
2	Ranjith	773428481	Not Received	Service Disconnected
0	Salee	773428482	Not Received	Problem with provider service
3	P.Alahuthurai	773428483	Received	
4	HIH	773428484	Received	
0	Rafeek	773428485	Not Received	Problem with provider service
5	HIH	773428486	Not Received	Line is Disconnected

6	J.A.C.Priyadarshani	773428487	Received	Message received but she couldn't understand message because the mobile software is removed
0	Not Nominated	773428488	Received	
7	A.M.Yasar	773428477	Received	
8	K.Nishantha	773428478	Not received	Problem with provider service
0	Ajith Soyza	773428479	Received	Software Problem; Message received but couldn't understand because displayed only the DEWN software name
9	HIH Back up	773428476	Received	
10	HIH Back Up	773428475	Received	

44. APPENDIX J – DATA COLLECTION SHEETS

44.1. Datasheet 1 – ICT Guardian Alert Log

		<u>Last Mile Hazard Warning System</u>	LMHWS Datasheet 001
		<u>Last mile -</u> <div style="border: 1px solid black; width: 100%; height: 15px; margin: 5px 0;"></div>	
		<u>ALERT LOG</u>	
.u fpuhkk; Village		osia;%slalh khtl;lk; District	
,enqKq oskh iy fõ,dj fpil;j NeuKk; jpfjpAk; Received DateTime		ksl=;a l< oskh iy fõ,dj ntspapl;l NeuKk; jpfjpAk; Disseminate Date Time	

lreKdlr my; i|yka WmlrK w;ßka i¼fjdaoh wdmof f;dr;=re uOHia:dkfhka Tng ,enqKq NdKavh jgd rjqla wçkak –
 jaT nra;J fPo;f;Fwpg;gpl;Ls;s cgfuzq;fspy; ru;Nthja md;u;jj jfty; epiyaj;jhy; toq;fg;gl;l fUtpia Rw;wp tl;lkpl;Lf; fh;l;Lf.
 Please circle the ICT which you operate to receive Alerts from the Sarvodaya HIH.

ia:dk.; ýrl:kh epiyahd njhiyNgrp Fixed Line	cx.u ýrl:kh ifalf;fj; njhiyNgrp Java Phone	ù-ieÜ tP-nrl; VSAT	wdmod ikaksföök .=jkaúý,sh nra;kjp thndhyp AREA	<div style="border: 1px solid black; width: 100%; height: 15px; margin-bottom: 5px;"></div> WmlrK njhiy ,af;fg;ghl;L vr;rupg;Gf; fUtp Remote Alarm Device
--	---	--------------------------	--	--

□□□□□□□□□□x{d ^ mrSlaIK fyda WoajSmk & my; j.=fjs igyka l, hq;= w;r Tn .kq ,enQ l%shd udra.h o igyka lrkak
 fpuhkj;jpw;F fpilf;fg; ngWk; vitNaDk; guPl;rhj;jpa my;yJ cz;ikahd vr;rupf;iffs; njhlu;ghd tptuj;ij kw;Wk; re;ju;g;gj;ij
 gad;gLj;jpa tpjk; njhlu;ghf fPo;fhZk; gl;baiy)u;j;jp nra;J mDg;gpitf;fTk;

All alert is received, including tests and exercises, the Village ICT Guardian must record the Alert and describe the action taken.

wx.h %yk;	w.h ngWkjp	wx.h %yk;	w.h ngWkjp
ix{dj vr;rupf;if Alert		NdIdj: nkhop Language	
yÿQkAjkh milahsg;gLj;J du; Identifier		j¾.h tif Category	
hjkakd mDg;Ggtu; Sender		isoaêh rk;gtk; Event	
heöfö mDg;gpaJ Sent		yËish mtruk; Urgency	
::Ajh epiyik Status		±âlu Jbdk; Severity	
mKsúvfha iajNdjh jftypd; jd;ik msgType		iA:srNdjh epiyahd jd;ik Certainty	
ljqreka ioydo Jiw Scope			

--	--

<p>ix{d Ynsoh ,enqfkao ? □□□□ □□□□□□□□□□□□□□□□ / Did you hear the alerting sound? Yes/no and comments.</p>	
--	--

<p>ix{dj f;areus .ekSug myiqo ? □□□□ □□□□□□□□□□□□□□□□ / Was the alert message easy to understand? Yes/no and comments.</p>	
--	--

<p>□□□□□□□□□□□□□□□□? □□□□ □□□□□□□□□□□□□□□□ / Was the ICT easy to use? Yes/No and comments.</p>	
---	--

<div style="border: 1px solid black; width: 100%; height: 15px; margin-bottom: 5px;"></div> <div style="border: 1px solid black; width: 100%; height: 15px; margin-bottom: 5px;"></div> <p>/ Do you feel you have sufficient training to operate the ICT? Yes/No and comments.</p>	
--	--

<div style="border: 1px solid black; width: 100%; height: 15px; margin-bottom: 5px;"></div> <p>gpur;rpidfSk; fUj;Jf;fSk; Comments</p>	
---	--

<p>WmlrK NdrIref.a ku/ cgfuz nghWg;ghsupd; ngau; /ICT Guardian</p>	<p>w;aik / ifnahg;gk; Signature</p>	<p>Èkh /jpfjp Date</p>
--	---	----------------------------

44.2. Datasheet 3 – Community drills evaluation form

Page 1	<u>Last Mile Hazard Warning System</u> <u>.iudk fmryqre jevigygyk-m%yYakdj.sh iy idrdxYh /</u> <u>.Wjpf;fl;l mdu;j;j vr;rupf;if xOq;F Kiw /fpuhkpa xj:jpif</u> <u>kjpg:gPl;L-rhuhk;rKk; tpdhg:gj:jpuKk;</u> <u>Village Simulation Count-Summary and Questionnaire</u>	LMHWS Datasheet 003
---------------	--	--------------------------------------

.u / fpuhkk; / Village		osia;%slalh / khtl;lk; / District	
oskh /jpfjp / Date		fõ,dj / Neuk; / Time	

Please fill in the answers to the questions by asking the questions from the village simulation participants that are at the final assembly point.

ldKavh/ tu;f;fk; / Category	msßñ / Mz; / Male	.eyeKq / ngz; / Female	<uhs /rpWtu; / Children
.iïdiskaf.a iyNd.s;ajh/ vz;zpf;if / Number of Community Participants			

.iïdis mjq,a ixLHdj / FLk;g vz;zpf;if / Number of Families in Community	
.fus uqM ck.ykh/fpuhkj;jpd; nkhj;j rdj;njhif / Total Community Population	

Q1	<p>(a) .iĵdiska fldmuK ixLHdjla bj;ajSfñ ie,iqu ms,snoj ±kqj;aj isáfhao? / mtrufhy ntspNaw;wy; jpl;lk; njhlu;ghf vj;jid Ngu;fs; mwpe;Js;sdu; ? / How many knew the emergency evacuation plan for the community?</p> <p>(b) .iĵdiska fldmuK ixLHdjla bj;aùfñ ud¾.h ms,snoj wlue;a; m,l,ao?/ vj;jid Ngu; ntspNaw;wy; ghijfs; gw;wp Fyg;gkile;jtu;fshf ,Ue;jdu; ? / How many were confused over evacuation routes?</p> <p>(c) iEu wdmodyla i ydu bj;ajhdfñ ie,iqula Tfñ .iĵdiska i;=j ;snqfkao? (Tú /ke; / midj;J mdu;j;jq;fSf;Fk; Kfk; nfhLf;ff;\$ba jpl;lk; xd;W ,Uf;fpd;wjh ? / Does your community have a plan for all-hazards (yes/no and reasons)?</p> <p>(d) bj;a fkdjqkq .iĵdiska msßila isáfhao? / ntspNaw;wypd;NghJ fpuhkj;jpy; VjhtnjhU gpupT tpLg;gl;ljh ? / Were any parts of the village not evacuated?</p> <p>(e) bj;aùfñ ud¾.h yryd ndOl lsisjla ;snqfkao? (Wod:- yñßh yria ud¾., md,ñ, lgq lñi jeg, bj;al, fkdyeys WmlrK) / ntspNaw;wy; ghijapy; VjhtJ jilfs; ,Ue;jdth ? (ghyq;fs;>Gifapuj flitfs>fjTfs;> Kw;fk;gp Ntspfs;) Nghd;w / Were there any obstructions, stored materials, equipment blocking the evacuation paths, bridges, railway-crossings, doors, barbwire fences, etc.)</p>
----	--

<p>Q2</p>	<p>(a) .ijdiska w;r mj;sk wk;=re we.úfn l%u fudkjdo?/ vit cs;@u; vr;rupg;Gfshf ,Ue;jd ? / What were the local warning methods?</p> <p>(b) tu l%u ls%hd;aul lsúg .;jk ld,h?/ cs;@u; vr;rupg;G fUtpfis ,af;Ftjw;F vt;tsT Neuk; vLj;jj ? / How long did it take to activate the local warning systems?</p> <p>(c) wk;=re we.úfn ix{dj weiqkq .ijdiska ixLHdj ?/ vj;jid Ngu;fs; vr;rupg;G rkpfiQia mtjhdpj;jdu; ?/ How many heard the alarm?</p> <p>(d) ix{dj weiqkq .ijdiska u.ska ±kqj;a jqkq .ijdiska ixLHdj ? / vj;jid; Ngu;fs; vr;rupg;G rkpfiQia Nfl;ltu;fshy; mwpTWj;jg; gl;ldu;? / How many were notified by the people who heard the alarm?</p> <p>(e) wk;=re we.úfn ix{dj u.ska wk;=r meyeÈ,sj yÿkd.; yels ùo? bkamiq ta ioyd ls%hd;aul jSug fldmuK ld,hla ;snqfkao? / vr;rupf;if muptpg;G mghaj;ij NtWgLj;jp mwpe;J r%fj;jpw;F cupa mwptpg;ig toq;f Kbe;jjh ? Mk; >,y;iy vdpd; fhuzk; / Did the alarm distinctly identify the hazard? And the available time for the community to react (yes/no and reasons)?</p> <p>(f) wk;=re we.úfn ix{dj kdoùfuka wk;=rej wdrCIs; iaMdkh lrd hdug .;jk ld,h? /Kjy; vr;rupf;ifapypUe;J ghJfhg;ghd ,lj;jpw;F ntspNaww;g; gLk; tiuf;Fk; vt;tsT Neuk; vLj;jj ?How long did it take from first alarm to evacuate or move to shelter area?</p>
<p>Q3</p>	<p>(a) .ijdiska fldmuK ixLHdjla bj;aùfn fmryqreig iyNd.s ùug wlue;a; m,lf,ao ?/ jid Ngu;fSf;F ,e;j xj;jpifapy; fye;Jnfhs;s tpUg;gk; ,y;iy ? / How many did not want to participate in the Simulations?</p> <p>(b) ikaksfúok WmlrK fol ne.ska ,o .ijdiska fldmuK ixLHdjla bj;aùfn fmryqreig iyNd.sùo? / vj;jid Ngu; vspjpy; efuf;\$ba – gytPdg;gl;Nlhu;fs; tUifj; je;jpUe;jhu;fs; ? / How many mobility-in paired people present?</p> <p>(c) bj;aùfn fmryqreig iyNd.s fkdjSug fya;=?/ ,e;j xj;jpifapy; fye;Jnfhs;shjikf;F fhuzj;ij fhL;Lf.? / What</p>

	<p>are the reasons for the people not to participating in the Simulation?</p> <p>(d) .ñudkfha iEu m%foaYhlgw wk;=re we.ùfñ mKsúvh m%pdrKh ùo?/ cs;@u; mghaj;ij r%fj;jpdhy; vy;yh ,lj;jpYk; Nfl;f Kbe;jjh ? / Were local alarms for warning, heard from all occupied areas of the community?</p> <p>(e) wdmmod ioyd iqodkñ ùfñ lghq;= flfrys .ijdiskaf.a iyNd.S;ajh jeä lr.ekSug HIH bÈß ie,iqñ flfia úh hq;=o? / mdu;j;j;ij vjpu;nfhS;tjw;fhd jahu;g;gLj;Jjy; r%f gq;fspg;ig Kd;Ndw;w HIH jpl;lk; vt;thW cjt KbAk; ?/ How can the HIH plan in the future to improve the community participation in disaster preparedness?</p>
--	---

<p>Q4</p>	<p>(a) fuu jevigyk id³/₄;l f,i ms,s; a ixnHdj? /vj;jid fw;gid rk;gtq;fs; ntw;wfp;nfhz;ld ? How many thought the event was a success?</p> <p>(b) fuu jevigyfkys ÿ³/₄;j; d rdYshla we;s nj;a ;j ÿrg;a fuu wdmmod ikaksfúok ie,iqu ioyd iydh wjYH f,i is;= ixnHdj? /mtrufhy epiyf;F Kfk; nfhLg;gjw;fhd jpl;l;ij tpUj;jp nra;a NkYk; cjtp Njit vd;Wk; mjpy; gy gpur;rpids; cs;sd vd;Wk; vj;jid Ngu; epidj;jhu;fs; ?How many thought there were many problems and the village needed further assistance in developing an emergency response plan?</p> <p>(c) .ijdiska ioyd wdmmod l,uKdlrkh iñnkaoj ixúOdk iydh ,dCIKsl iydh iy ICT Ndú;h iñnkaoj iydh ;j ÿrg;a wjYHo? /ICT ia gad;gLj;JtjpYk; mtrufhy jpl;l;ij;jpYk; xOq;FgLj;jy;> njhopy; El;gk; vd;gtw;wpw;F Nkyjpf cjtp Njitah ? Does the community need additional help in organizational and/or technical areas of emergency planning and ICT usage?</p>
-----------	--

<p>Q5</p>	<p>(d) ICT WmlrK ksis wlddrfhka ls%hdlrkafkao? ls%hdfkdlrkafka kñ Bg fya;=? Kd;ndr;rupg;G cgfuz ,af;Fjy; njhlu;ghd tpsf;fk; nfhz;Ls;sPuh ? ,y;iyNay; mjw;fhd fhuzk; vd;d ? Did the community ICT for early warnings function properly? If no what were the faults?</p>
-----------	--

	<p>(e) Were any other faults or deficiencies noted Yes/No; (e.g. procedures inadequate, response time too long, announcements inaudible etc)</p>
--	--

Use space below for additional remarks:

m%dfaoYSh Èia;s%la kshuq fiajl/gpuNjr ,izg;ghsu; / Divisional Coordinator	w;aik / ifnahg;gk; Signature	Èkh /jpfjp Date
--	---------------------------------	--------------------

44.3. Datasheet 4 – Counting people at strategic points

Page 1		<u>Last Mile Hazard Warning System</u> reiapk ia:dkfha f;dr;=re / ,Wjp mdu;j;j vr;rupf;if <u>xOq;F Kiw -xd;W\$Lk; vz;zpf;if</u> <u>Assemble Point Counts</u>		LMHWS Datasheet 004
.u fpuhkk; Village		reiapk ia:dkh xd;W\$Lk; ,lk; Assemble Point		.eyeKq / msñ / <uhs Mz;/ngz;/rpWtu; Male/ Female/ Children
oskh Muk;g jpgpAk; NeuKk; Start Date and Time		ksl;=;a l< oskh iy fõ,dj KbT Neuk; Finish Time		

- **iEu ñks;a;= 15lg jrla wod, fldgqfõ l;sr ,l=K oukak' / xt;nthU 15 tJ epkplj;jpYk; Fwpj;j rJuj;jpy; Fwpj;j Neu;ij ,ITk; /**
Every 15 minutes record the time in the last box crossed
- **by, jñ fl,pf¾ fldgqfjka wdrñN lr, .Kkh lrk iaMdkh yer hk iEu wfhla fjkqfjkau l;sr i,l=Kq lrkak**
- **cq;fs; kjpg;gPl;L l;jsj;jpypUe;J flf;Fk; xt;nthU egufspdJk; Fwpg;GfSf;fhf rJug;ngl;bfs;py; Nky; ,lg;gf;fkpUe;J Gs;sb ,ITk;.**
- **Cross out the boxes starting from upper left corner working each row for every person that passed your counting station**

1	2	3	4	5	6	7	8	9	10	11	12	13	14	15	16	17	18	19	20
21	22	23	24	25	26	27	28	29	30	31	32	33	34	35	36	37	38	39	40
41	42	43	44	45	46	47	48	49	50	51	52	53	54	55	56	57	58	59	60
61	62	63	64	65	66	67	68	69	70	71	72	73	74	75	76	77	78	79	80
81	82	83	84	85	86	87	88	89	90	91	92	93	94	95	96	97	98	99	100
101	102	103	104	105	106	107	108	109	110	111	112	113	114	115	116	117	118	119	120
121	122	123	124	125	126	127	128	129	130	131	132	133	134	135	136	137	138	139	140
141	142	143	144	145	146	147	148	149	150	151	152	153	154	155	156	157	158	159	160
161	162	163	164	165	166	167	168	169	170	171	172	173	174	175	176	177	178	179	180
181	182	183	184	185	186	187	188	189	190	191	192	193	194	195	196	197	198	199	200

.....
 n,Odßhd / cupikf;fhuu ;/ Authorized Person

.....
 w;aik / ifnahg;gk; / Signature

	Time and Date	
fodalh NfhshU/Njhrk; Problem		
yels kī fodalh ms<sn úia;rhla imhkak KbAkhapd; Nfhshupd; jd;ikia Fwpg;gpLf Description of the problem		

	<i>Èkh iy fõ,dj jpfjpAk; NeuKk;</i>	<i>Tjk wdlrh mDg;Gk; tpjk; (fax, phone, email, sms, etc)</i>	<i>jd¾:dj ,nd .;af;a mwpf;ifia ngw;Wf; nfhz;ltu; (HIH person name):</i>
jtW/gpur;rpId/gpiof;Fwpa mwpf;if mDg;gg;gl;lJ Fault/Problem/Error Report Sent			
ngwg;gl;lJ; jPu;Tfs; Solution Received			

If the solution was from a source other than the HIH, then specify source and comment on how you got the external help in the additional information section below; or you may use the area to provide any other relevant information.

jeä ðia;r Nkyjpf jfty;fs; Comments :	
--	--

Èia;%sla kshuq fiajlf.a ku khtl;l ,izg;ghsuJ ngau; District Coordinator	_____ w;aik ifnahg;gk; Signature	_____ Èkh jpfjp Date
---	---	-------------------------------

44.6. Datasheet 7- Event of Interest form

Authentication Signature: _____ Approval Signature: _____

Print Name: _____ Print Name: _____

ALERT SEGMENT 0004

Alert
(Required)

Message ID: _____ Sender ID: _____
(Required) (Required)

Sent Date/Time: _____ / _____ / _____ / _____ Message Status: Actual Exercise System Test Draft
(Required) Day Month Year Time(Sent) (Required)

Source: _____ Message Type: Alert Update Cancel Ack Error
(Optional) (Required)

Scope: Public Restricted Private

Restriction: _____ Handling Code: _____
(Conditional) (Optional)

Reference Ids: _____ Incident Ids: _____
(Optional) (Optional)

Note: _____

Address: _____

INFORMATION SEGMENT

Info: _____ Language: _____
(Optional) (Optional)

Event Category: Geo Met Safety Security Rescue Fire Health Env Transport Info
(Required)

Event Type: _____

Response Type: Shelter Evacuate Execute Monitor Assess None
(Required) (Optional)

Urgency: Immediate Expected Future Past Unknown
(Required)

Severity: Extreme Severe Moderate Minor Unknown
(Required)

Certainty: Observed Likely Possible Unlikely Unknown
(Required)

Audience: _____ Event Code: _____ Effective Date/Time: _____ / _____ / _____ / _____
(Optional) (Optional) (Optional) Day Month Year Time(Effective)

OnSet Date/Time: _____ / _____ / _____ / _____ Expiration Date/Time: _____ / _____ / _____ / _____
(Optional) Day Month Year Time(Onset) (Optional) Day Month Year Time(Expiration)

Sender Name: _____ Headline: _____
(Optional) (Optional)

Event Description: _____ Instructions: _____
(Optional) (Optional)

Information URL (web): _____ Contact Info: _____
(Optional) (Optional)

Parameter: _____
(Optional)

44.7. Datasheet 8 – HIH Monitor drill performance evaluation

<div style="border: 1px solid black; width: 100%; height: 15px; margin-bottom: 5px;"></div> <div style="border: 1px solid black; width: 100%; height: 15px; margin-bottom: 5px;"></div> <div style="border: 1px solid black; width: 100%; height: 15px; margin-bottom: 5px;"></div> <div style="border: 1px solid black; width: 100%; height: 15px; margin-bottom: 5px;"></div> <div style="border: 1px solid black; width: 100%; height: 15px; margin-bottom: 5px;"></div> <div style="border: 1px solid black; width: 100%; height: 15px; margin-bottom: 5px;"></div> <p>Observer Name, Occupation, Affiliation, designation</p>			
<div style="border: 1px solid black; width: 100%; height: 15px; margin-bottom: 5px;"></div> <p>Date:</p>		<div style="border: 1px solid black; width: 100%; height: 15px; margin-bottom: 5px;"></div> <div style="border: 1px solid black; width: 100%; height: 15px; margin-bottom: 5px;"></div> <p>Time:</p>	

Write the name, role, and designation of HIH resource person participating in the last-mile HazInfo Project simulation activities.

	<div style="border: 1px solid black; width: 100%; height: 15px;"></div> <u>Resource Person</u>	<div style="border: 1px solid black; width: 100%; height: 15px;"></div> <u>Designation</u>	<div style="border: 1px solid black; width: 100%; height: 15px;"></div> <u>Role</u>	<div style="border: 1px solid black; width: 100%; height: 15px;"></div> <u>Other Details</u>
A				
B				
C				
D				
E				

--	--	--	--	--

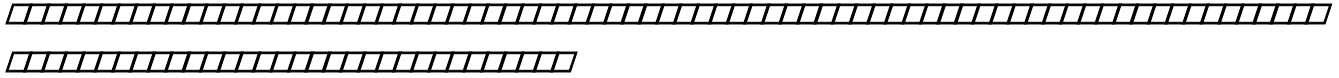

Indicate the starting and ending time for each of the activities below and provide remarks –

	<u>Activity</u>	<u>Start Time</u>	<u>End Time</u>	<u>Remarks</u>
1	ix{d Download alert into PC in HIH (i.e. hih email inbox)			
2	ix{dj ,enqKq njg ,ndoQka mqoa.,hdg oekajSu Send acknowledgement to Alert Sender at source			
3	Create Event of Interest Document			
4	Obtain approval from Sarvodaya Executive			
5	DEWNS CAP Generate CAP text messages using DEWNS to send to RAD			

--

	<hr/> w;aik / ifnahg;gk; Signature	<hr/> Èkh /jpfjp Date
--	--	-----------------------------

45. APPENDIX K: HAZINFO SUPPLEMENTAL FINAL REPORT

**Regional Dissemination of Findings from the Last-Mile
Hazard Information Dissemination Pilot Project**

(HazInfo Supplemental Project)

Grant No.: 103553-001

Grant Period: 01-June-2007 to 29-February-2008

Report Presentation Date: 15-March-2008



Submitted to IDRC by:

Natasha Udu-gama, Dissemination Manager - HazInfo

LIRNEasia

12 Balcombe Place

Colombo 8 Sri Lanka

Tel: +94 11 452 7647 Fax: +94 11 452 7648

E-mail: samarajiva@lirne.net

Web site: www.LIRNEasia.net

SRI LANKA

LIRNEasia is a regional information and communication technology (ICT) policy and regulation capacity-building organization active across the Asia Pacific. LIRNEasia's program of actionable research seeks to identify the institutional constraints to effective use of ICTs to improve the lives of the people of the Asia Pacific, not simply in abstract terms but in country context, and to work collaboratively with multiple stakeholders to catalyze the changes conducive to greater participation by users and suppliers. LIRNEasia's overall mission of capacity building seeks to contribute to building capacity for evidence-based intervention in the public-policy process by persons attuned to the specific national contexts within which policies are made and implemented. Additional information is available at www.lirneasia.net.

TABLE OF CONTENTS

1.	SYNTHESIS	231
2.	RESEARCH PROBLEM	231
3.	RESEARCH FINDINGS	232
4.	FULFILLMENT OF OBJECTIVES	232
5.	PROJECT DESIGN AND IMPLEMENTATION	232
6.	PROJECT OUTPUTS AND DISSEMINATION	233

CONFERENCES/WORKSHOPS: _____ 233

2nd International ISCRAM-CHINA Workshop: *Harbin Engineering University, August 26-27 2007* 40

“The Role of Telecom Operators and Broadcasters in a National Public Warning System”, *BMICH, Sri Lanka, September 7, 2007* _____ 40

1st Wireless Rural and Emergency Communications Conference: Rome, Italy. October 1-2, 2007 40

“Sharing Knowledge on Last-Mile Warning: Community-based Last-Mile Warning Systems”: Dhaka, Bangladesh. October 25, 2007	40
19th Meeting of the Wireless World Research Forum: Indian Institute of Technology, Madras, November 2007	40
“Sharing Knowledge on Last-Mile Warning: Community-Based Last-Mile Warning Systems”: New Delhi, November 19, 2007	38
“Sharing Knowledge on Last-Mile Warning: Community-Based Last-Mile Warning Systems”: Jakarta, Indonesia. March 5, 2008	38
GK3 Session ET4: Emerging Technologies Session on “Making Communities Disaster Resilient”: Kuala Lumpur, Malaysia. December 11, 2007	251
CPRsouth2 “Empowering rural communities through ICT policy and research”: Chennai, India, December 15-18, 2007	38
GK3 Session Paper – “Promoting Community Disaster Resilience through Technology, Training and Community Empowerment: The HazInfo Experience”	263
CPRsouth2: Empowering rural communities through ICT policy and research IIT-Madras, Chennai, India; December 14-18, 2007	263
<i>HazInfo Documentary: “The Long Last Mile”</i>	265
<i>HazInfo DVD Distribution</i>	265
<u>CONFERENCE PAPERS ACCEPTED, NOT ATTENDED:</u>	265
4th International Conference on Information Systems for Crisis Response and Management (ISCRAM) – Delft, 13-16 May 2007	265
Wireless Personal Multimedia Communications (WPMC) Conference: Jaipur, India. 3-6 December 2007	265
<u>FUTURE CONFERENCES/WORKSHOPS:</u>	266
International Conference on Earthquake Engineering and Disaster Mitigation 2008 (ICEEDM): Jakarta, Indonesia, 14 April 2008	266
<u>MEDIA COVERAGE:</u>	266
<i>Print</i> –	266
<i>TV</i> –	267
7. CAPACITY-BUILDING	268
8. PROJECT MANAGEMENT	268
9. IMPACT	269

10. OVERALL ASSESSMENT 270**11. RECOMMENDATIONS 271**

Appendix A: Proposed Participants for HazInfo Indonesia Workshop _____ 272

Appendix B: Distribution of HazInfo DVDs _____ 275

1. Synthesis

Following the successful implementation of the “Evaluating Last-Mile Hazard Information Dissemination” (HazInfo) pilot project, it was decided that regional dissemination of the pilot’s findings would enhance the project’s status as a path-breaker in last-mile risk communication for communities at-risk.

The HazInfo supplemental project, as this dissemination portion of the original HazInfo project was called, encouraged the sharing of findings and lessons learned from the HazInfo project with similar last-mile initiatives in three select Bay of Bengal countries (Bangladesh, India and Indonesia). This was achieved by organizing a workshop in each of the three countries in partnership with a local disaster risk reduction/disaster preparedness organization.

The workshops were structured into five sessions with a portion of an early warning system as the main topic (i.e. First Responder Action). Basically, each session featured one speaker from the HazInfo Sri Lanka project and one speaker from the host country. Several pointed questions were posed within the agenda for the ensuing discussions. The workshops unearthed much interest in the topic of last-mile hazard information dissemination for communities and shed light on a topic not otherwise discussed in typical workshop on early warning. Moreover, it produced interest in replicating the HazInfo project to suit the particular hazard makeup of the chosen country.

2. Research problem

The “Evaluating Last-Mile Hazard Information Dissemination” (HazInfo) pilot project could not achieve its proper status without appropriate dissemination of its findings within the region. Given that the pilot’s purpose was to test various technologies’ usefulness in the “last-mile” of a national early warning system, its implications for neighboring countries, particularly around the Bay of Bengal, are highly relevant. Thus, the need for a series of regional workshops

arose with the central idea being that the HazInfo pilot would be the focus. Lessons would be drawn from each workshop for purposes of comparison and contrasting with similar host country initiatives.

3. Research findings

The workshops conducted between the inception of this supplemental (June 2007) until the present (February 2008), indicate a number of strong successes. It succeeded in its main goal of engaging practitioners and experts in discussing and speaking to the issue of community-based early warning systems and the potential of ICTs as a revolutionary means of disseminating warning to communities at-risk.

The main research results should be described and interpreted by highlighting the contribution to knowledge that this project represents from a scientific and policy perspective.

4. Fulfillment of objectives

The primary objective of the HazInfo supplemental project was to organize and hold a series of three regional workshops designed to discuss and compare similar community-based early warning systems. This objective was achieved with 75% completed. Meaning that workshops were conducted in Sri Lanka, Bangladesh and India, but not Indonesia. The Indonesia workshop could not be fulfilled due to logistical problems in obtaining visas for Sri Lankan speakers. The Sri Lanka workshop was an unexpected, unplanned (at the time of supplemental proposal submission) event, which not only featured the findings of the HazInfo project, but also brought together Sri Lankan telecom providers to initiate working committees (with the support of the Ministry of Disaster Management and Human Rights) to find effective an effective solution to issuing hazard alerts to the public.

5. Project design and implementation

The activities in this project were workshops. Each workshop was designed to discuss each part of an early warning system including a discussion period. This allowed for maximum speaker-audience interaction so as to derive as many lessons learned. In the final workshop in Indonesia, it was hoped that the session discussion would be revamped such that participants would break off into groups and have worksheets of questions that would encourage further discussion on the major topics.

In terms of gender, speakers from both genders were invited for both the Bangladeshi and Indian workshops. Unfortunately, it was found that during both workshops there was only one female speaker, respectively. More often than not, invited female speakers would be unable to attend due to extenuating circumstances or would hand over the speaking part to their male colleagues.

6. Project outputs and dissemination

Conferences/Workshops:

2nd International ISCRAM-CHINA Workshop: Harbin Engineering University, August 26-27 2007

Attendee: Nuwan Waidyanatha, Project Manager

The 2nd International Workshop on Information Systems for Crisis Response and Management, in China (ISCRAM-CHINA-20071), is a post-conference meeting to the International Disaster Reduction Conference2 (IDRC). ISCRAM-CHINA took place in Harbin from August 26-27, 2007. The ISCRAM-Community3 and the School of Economics and Management - Harbin Engineering University4 (HARBEU), jointly organized the conference. The Workshop provided an outstanding opportunity for researchers, scholars, teachers, students, practitioners and policy makers in China as well as invited International delegates to address and discuss new trends and challenges in the area of Information Systems for Crisis Response and Management.

The subject matter dealt with aspect of design, development, deployment, operation, and evaluation of information systems for crisis response and management. Authors focused on tools, functionality, and/or interfaces that were being or should be provided for human users involved with crisis response and management. Contributions covered Crisis Response and Management in any phase, intersection of phases, and/or integration of phases of the Emergency Management and Preparedness lifecycle: Planning, Training, Mitigation, Detection, Alerting, Response, Recovery, and Assessment.

Evaluating Last-Mile Hazard Information Dissemination: A Research Project, or HazInfo Project, research findings were presented during Session 1: Information Systems along with

20 other papers that were presented in the same session. The HazInfo paper titled “Common Alerting Protocol Message Broker for Last-Mile Hazard Warning System in Sri Lanka: An Essential Component”, edited by Bartel Van de Walle (bartel@uvt.nl), Xiaodi Li (lixiaodi2000@hotmail.com), and Shuyu Zhang, was 1 of 115 papers published in the workshop proceedings, pages 59-64, selected from over 200 submissions. The residual session themes were – Business/Organization, Public Organizations/Government, and Mathematical Modeling.

The HazInfo paper that discussed cutting edge research in the use of Common Alerting Protocol (CAP) was passionately received by the participants. Moreover, interested stakeholders expressed interest in collaborating in future research that is to be lead by LIRNEasia; especially in the development of the “P2P Multilanguage CAP Broker” for the region.

“The Role of Telecom Operators and Broadcasters in a National Public Warning System”, BMICH, Sri Lanka, September 7, 2007

Attendees: Rohan Samarajiva, Natasha Udu-gama

“The Role of Telecom Operators and Broadcasters in a National Public Warning System”. On Friday, September 7, 2007, the Ministry of Disaster Management and Human Rights (MDMHR), with the support of LIRNEasia, held a meeting on “The Role of Telecom Operators and Broadcasters in a National Public Warning System” with a six of the eight major telecom operators, as well as several disaster management-related government agencies (NBRO, Irrigation Dept., Meteorology Dept., CCP, etc.), UNDP, and a few technical institutes.

Mr. P.D. Amarasinghe, Secretary of the MDMHR, opened the session by discussing the particular disaster role of each of the government agencies asked to attend. He acknowledged the government’s important role in disaster warning. The role of the Disaster Management Center (DMC) will be to disseminate warnings to first responders through various means – RANet, SMS, and fax. First responders will be media, police and armed forces, district coordinators of DMC, and other organizations (NGOs, community). Currently, the MDMHR is in the process of developing a proposal for a network of dissemination towers at Hikkaduwa, Kalmunai and Point Pedro. There will be a total of 50 by the end of this year (latest, Jan/Feb 2008). With further funding, the MDMHR will establish 10 EOCs, 4 EMC, in

addition to four managed by police & armed forces. Thus, he declared that the basic warning system is in place and asked how might the telecom operators contribute to a public warning notification system.

Major General Gamini Hettiarachchi, Director General of the DMC gave a presentation on the Disaster Early Warning and Dissemination Strategy of Sri Lanka. He reviewed the progress of disaster management since the tsunami, through the Disaster Management Act No. 13 of 2005, and the establishment of the National Council on Disaster Management in the same year. He stated that there are currently 3 early warning towers, but by the end of next year there should be a total of 150. Emergency response committees have been formed including SLT, municipalities, 25 district secretaries and 9 province secretaries.

Mr. Anjula Godakumbara from Dialog Telekom made a presentation on Dialog's involvement in early warning dissemination. Dialog and the Ministry of Disaster Management and Human Rights have signed an MoU. Dialog along with MicroImage and the University of Moratuwa Research Lab looked into using GSM communication in disaster early warning dissemination by setting up the Disaster and Early Warning Network (DEWN). This has SMS and cell broadcast capabilities. The benefits of the DEWN system are that it is low-cost and uses existing communication infrastructure. Dialog reiterated the fact that only the DMC has the authority to send disaster warnings. For more information on this initiative see www.dialog.lk/dewn.

Prof. Rohan Samarajiva, Executive Director – LIRNEasia, gave a presentation on “Effective use of telecom & electronic media in disaster risk reduction”. He asked how will the DMC communicate with the media and the phone companies. The government must have internal protocols, which must be double-checked with government officials. There must a technically sound system in place to get to all media and must be capable of showing if people got the message and in the right language. LIRNEasia recommends the Common Alerting Protocol (CAP) system with additional software, which is single input, multi-output, multi-language. LIRNEasia can develop this within a few months. Essentially this means that once a button is pressed, the software will translate the message accordingly and send the message by SMS, cell broadcast, fax, etc. The government is clearly interested in standard procedures and templates. Therefore, it would be in its best interest to approve a standard template in the language and simply insert the proper word as necessary. Prof. Samarajiva posed yet

another question: How might the government ensure that the person issuing the warning is reliable and not someone who plans to sabotage the process? There must be some sort of encryption or verification method so that receivers know that the warning is official.

In discussing the use of ICTs in public warning (an area not covered by the Last-Mile HazInfo Project), Samarajiva suggested that two of the most difficult cases be addressed: a passenger in a moving train and a tourist at the Yala National Park. If public warning can reach these two individuals, all the other less difficult problems can be solved. In both cases, he suggested that cell broadcasting would be the most important technology, though there may be areas within Yala that would be out of signal coverage, in which case no public warning was possible.

The discussion that followed the presentations. Mr. Hettiarachchi called for a link with service providers to develop automated procedures. Secretary Amarasinghe suggested that there be a technical committee set up for hearing recommendations on early warning from telecom providers and broadcasters. It was decided that there would be two separate technical committees – one for telecom providers and the other for broadcasters. Dates and agendas for the first technical committee meetings of telecom providers and broadcasters were not discussed.

Mr. U.W.L. Chandradasa, Director – DMC, wrapped up the session by reiterating that the DMC is responsible for disseminating warning messages. Regarding first responders, he agreed that other agencies could be involved. He acknowledged that government alone cannot take charge of “Last Mile” warning without the contributions of telecom providers, broadcasters and the private sector.

1st Wireless Rural and Emergency Communications Conference: Rome, Italy. October 1-2, 2007

Attendee: Dr. Gordon Gow, University of Alberta, Canada

The paper "Community-based Hazard Warnings in Rural Sri Lanka: Performance of Alerting and Notification in a Last-Mile Message Relay," written by Nuwan Waidyanatha (first author), Gordon Gow – University of Alberta, and Peter Anderson from Simon Fraser University.

The paper presents research findings from HazInfo, where a subset of indicators is compared

for evaluating system design and performance of the LM-HWS. In particular, it introduces and defines measures for "reliability" and "effectiveness" for assessing the utility of technologies deployed in the last-mile of the HazInfo Project. The measures were applied to data gathered from exercises conducted with the HazInfo System to determine how various combinations of ICTs perform in terms of alerting the ICT Guardians as well as conveying the contents of warning messages.

An important contribution of the paper is the concept of "complementary redundancy." Test results using the reliability and effectiveness measures in the study, showed that overall scores for end-user devices varied considerably and highlighted some important concerns for user training and unforeseen implementation issues. For example, addressable satellite radios rated high in terms of reliability but relatively low in terms of effectiveness, as their messaging capability is limited (English only) and because they are nomadic but not mobile, meaning that the units cannot accompany the ICT-G from place to place (thereby reducing the score on the "Active Alerting" index). On the other hand, mobile phones scored high on effectiveness, with capability to display warning messages in three languages and because they are a form of personal media that will usually accompany the ICT-G at all times. However, mobile phones scored less reliably because of signal coverage and battery maintenance issues.

When combined, however, addressable satellite radio and mobile phone technology compensate for each other's deficiencies and produce a synergy we refer to in the paper as "complementary redundancy." As such, results from the initial field tests and technology assessment suggest that appropriate combinations of wireless technologies will provide the best performance if they exhibit complementary redundancy. These results have a number of implications for emergency planners.

First, planners should consider deployment of multiple devices with the aim of achieving complementary redundancy in reliability and effectiveness at the last-mile. Second, planners should adopt the Common Alerting Protocol because of its ability to support the goal of complementary redundancy by providing consistent and complete messaging across multiple devices. Third, that research is needed to further refine the reliability and effectiveness measures into a more robust index for assessing public warning technologies.

The paper presentation was well received and questions arose about security provisions in the HazInfo system. Security does remain a concern but that significant progress has already been made with provisions included in the HazInfo CAP profile as well as lower layer security measures built into the various ICT gateways, such as the WorldSpace satellite radio access gateway.

The IEEE Communications Society and Italian communications vendor and defense contractor Selex Communications sponsored WRECOM 2007. The aim of the conference (Wireless and Rural Emergency Communications --WRECOM) was to bring together research on various facets of wireless broadband communications for emergencies and disasters, particularly in rural settings where infrastructure may be limited or non-existent. To that end, various sessions covered wireless mesh networks, WIMAX and TETRA technologies, satellite services, as well as operational experiences with emergencies and public safety networks. Being an IEEE conference, most sessions were technical at an engineering level and addressed specialized topics such as routing protocols, transmission control, and technical performance analysis. Unfortunately, several important research papers (e.g., mesh networking in rural areas) presented findings with no mention of the potential application to emergency management! Mesh networking is not as easy as one might be led to believe in the popular literature.

A study led by Nicholas Race from Lancaster University, for instance, has followed the deployment of a mesh network in a small UK village for the past three years, with findings that suggest governance issues are significant. However, the project also noted that user interest and participation in the upkeep and active development of the network was enhanced in a mesh architecture setting. For the HazInfo project, these findings may shed some light on the challenge of long-term sustainability of the system and for building local technical know-how and local capabilities to further integrate the network into everyday activities beyond hazard warning.

Roberto Saracco from Telecom Italia spoke about several paradigms that might be applied to emergency communications services, such as load sharing, broadcasting, peer to peer, and bit/video torrents. He then went on to explain that the "layered" or "mashed" paradigm is growing in importance, with the likes of Google Maps and so forth. Linking all these

paradigms is a tension that emergency planners and policymakers must content with; namely, the choice between piggybacking on commercial networks and the deployment of dedicated infrastructure and services. Of course, the problem with the former is concerns about guaranteed quality of service during critical situations. The concern about the latter is cost and under-utilization. Somewhere in between--and perhaps this is where layered/mashed systems come into play--is a balance between dedicated, specialized services and cost effectiveness.

The US and other countries are now dealing with these economics of emergency communications in terms of the next generation of first responder radio systems. In terms of public warning, HazInfo has been innovative in terms of rethinking the model. By choosing to implement an open source like Common Alerting Protocol and by working closely with industry stakeholders to connect communities using everyday technologies, the project has in effect created a layered system that can in future expand in functionality and scope through mash-up applications with, for example, Google Earth for map sharing, as well as other applications as the need becomes evident. The ongoing challenge is to take this to the next level through a sustained research project that builds on the current achievement.

“Sharing Knowledge on Last-Mile Warning: Community-based Last-Mile Warning Systems”: Dhaka, Bangladesh. October 25, 2007

Attendees: Rohan Samarajiva, Natasha Udu-gama, Nuwan Waidyanatha

“Sharing Knowledge on Last-Mile Warning: Community-based Last-Mile Warning Systems”: The workshop took place in Dhaka on October 25, 2007. LIRNEasia and Bangladesh Network Office for Urban Safety (BNUS) – Bangladesh University of Engineering and Technology jointly organized the Workshop. The Workshop provided an outstanding opportunity for researchers, students, practitioners, and policy makers in Sri Lanka and Bangladesh as well as invited international private sector participants to address and discuss early warning activities from the South Asia Region.

5. The focus was on:

- Obtaining feedback on the findings of “Evaluating Last-Mile Hazard Warning Dissemination: A Research Project”,
- Exchanging lessons learned from end-to-end hazard detection and alerting systems that serve grassroots communities in Bangladesh,
- Merging knowledge from Bangladesh to develop practical solutions for communicating

risk information to rural communities

- Analyze and determine methodologies for measuring the performance of Community-based Early Warning Systems
- Commencing dialogue on the development of a regional last mile warning system.

6.

The excitement started with heated debates between the academics and the bureaucrats. Dr. AMM Safiullah, Vice Chancellor of BUET acted as a moderator to point out the mistakes made during past events and the need to upgrade existing systems based on the lessons learned and not immerse in the glory of “half baked” systems. The Bangladeshi participants agreed on the proof that the existing systems for Cyclone preparedness do not apply to all-hazards; especially tsunami and earthquake; modification is eminent.

The audience had to be reminded constantly that the LIRNEasia tested Last-Mile Hazard Warning System was not a traditional warning system that is usually used by governments but it was a community-based model used for alert and notification. The HazInfo project and other similar community-based hazard information systems can only be responsible for providing clear and accurate hazard information alerts. Another issue that arose from discussions, was whether individual nations within the South Asian region should replicate hazard analysis, leave that responsibility to international hazard analysis organizations (such as the Pacific Tsunami Warning Center), or have a regional hazard analysis entity. Currently, Bangladesh is in the process of replicating similar tsunami models and earthquake risk maps already available at international hazard analysis organizations. The much-studied Common Alerting Protocol (CAP) used in the HazInfo project was new to the Bangladesh audience. They are yet to understand the value and strengths of using this content standard.

Table 71 –Presentations and notes from each of the sessions

Presentation Title and Speaker	Presentation Main Points	Rapporteur Notes/Comments
<p>Inauguration</p> <p>Mr. K. M. Massud Siddiqui, Director General, Disaster Management Bureau (DMB)</p> <p>dmb@bttb.net.bd</p>	<p>It is a tricky subject for government to make early warning</p> <p>Need to identify technical deficiencies</p> <p>Lessons are not only for government policy makers but also must activate CBO, NGO, Private Sector, Civil Society, Medics, etc</p> <p>DG invited LIRNEasia to contact his bureau for future collaborative work</p>	<p>Submitted: March 01, 2008</p>
<p>Elements of Community-based warning</p> <p>Prof. Rohan Samarajiva, Executive Director, LIRNEasia</p> <p>samarajiva@lirne.net</p>	<p>ICTs play a key role in distancing the physical world where hazards occur from the symbolic world where media and first responders live giving time to alert the public</p> <p>Elements comprise national early warning center, government first-responders, media, community</p> <p>CAP Broker a 1-to-many software application is an essential non-existent component essential for last-mile warnings</p> <p>Planners must take in to consideration Complementary Redundancy when deploying ICTs in communities for alert and notification</p>	
<p>Discussion</p> <p>Director, Bangladesh Meteorological Department</p> <p>directorbmd2005@yahoo.com</p>	<p>Cyclone warnings are initiated by the Meteorological department</p> <p>Tsunami warnings are initiated by the Geological department, which was practiced during Nias earthquake in March 2006 as well as Bengkulu earthquake in September 2007</p> <p>Bulletin received from Japan had mentioned that it would take 9 hours before tsunami would hit Bangladesh coast but did not mention wave height; hence ran simulation model to estimate wave parameters</p> <p>Warning was issued and withdrawn at 0120 September 12th Bangladesh Govt. instructed to “play fail safe”</p>	<p>Heated debate between director and audience based on the fact that experts were not consulted prior to issuing warning</p> <p>General public was forced to understand expert knowledge in early warning</p>
<p>Session I: Local Transmission of Warning</p> <p>An Overview of</p>	<p>Overview of CPP</p> <p>CPP and ways in which²⁴¹ local communities receive information about cyclones through BRCS’ extensive network of trained</p>	<p>How are volunteers trained to receive and disseminate cyclone information?</p>

LIRNEasia udu-gama@lirneasia.net		
Session V: Next Steps Roles of policymakers, regulators, private sector and civil society Prof. Rohan Samarajiva, Executive Director, LIRNEasia (samarajiva@lirne.net)	Working with incomplete probabilistic information Cannot do disaster management work on usual turf based politics Early warning should give priority to “rapid onset’ hazards, which will be a catalyst to solving other hazard warning events	Sri Lanka has recorded history of 8 – 9 tsunamis in the past

The workshop initiated much healthy debate and discussion on the issue of early warning, particularly on the government’s provision of early warning to Bangladeshi communities. Government officials in attendance were most vociferous in defending existing EW infrastructure – particularly its monitoring and detection equipment. What was lacking, however, was government acknowledgement and interest in equipping the “last mile” to respond effectively to warnings.

Mr. Md. Nasir Ullah of the Cyclone Preparedness Program (CPP) described an early warning system very much akin to the HazInfo system in that it utilized information technology (i.e. transistor radios) and trained locals (i.e. militia or *Ansars*). The most significant difference between the two systems is the use of transistor radios in CPP-Bangladesh, while the technology stressed in HazInfo is a combination of technology – mobile and satellite radio.

19th Meeting of the Wireless World Research Forum: Indian Institute of Technology, Madras, November 2007

Attendees: Nuwan Waidyantha, HazInfo Project Manager

The Forum took place in Le Meridien Hotel from November 5 - 7, 2007. The conference was jointly organized by the WWRF, Midas, and the Indian Institute of Technology - Madras. The forum provided an outstanding opportunity for researchers, scholars, operators, original-equipment-manufacturers and policy makers working in the area of wireless communications to present and discuss the trends of the various technologies, latest research/developments, and services/applications in the field. The forum offered several Plenary Sessions, Working Groups (WG), and Special Interest Groups (SIG), which focused on disciplines within the global wireless communications community.

In general the theme was to shape the global wireless future by develop a common vision for the year 2020. Moreover, the forum focused on influencing the decision makers' views of the wireless world, enable powerful R&D collaborations, and advance wireless frontiers to serve the global customers. A main aspect of all the speakers was on the need to optimize the Kilo Bytes per second per Hertz per Cell (KB/Sec/Hz/Cell) in order to achieve very high spectrum efficiencies. The routes to the wireless future are WiMax (802.16) for the IT community and 3GPP/LTE for the Telecommunication community. In terms of commercial roll out, technologies such as cognitive radio are beyond the 2020. The overall impression exemplified by the experts is that wireless broadband such as WiMax could not replace the kind of capacity and services that are offered by wired broadband such as DSL in the present day of the game. In all cases the backhaul problem cannot be neglected.

Overall forum was quite intriguing especially to see the actual progress of cutting edge wireless technologies such as WiMax, LTE, etc that are paving the way for the communication industries to take them to the next level. Most importantly the researchers laid out the truth about the shortcomings and the realistic potential of the innovative technologies, which seem to defy theoretical frameworks. If not had been exposed to this forum the knowledge and awareness of the current state of affairs in the wireless world would have been oblivious and backwards.

Two papers submitted by authors from LIRNEasia were accepted for presentation in 2 different working groups and publication in forum proceedings. The first paper titled “Challenges of Optimizing Common Alerting Protocol for SMS based GSM Devices”⁴ was an output of the “Evaluating Last-Mile Hazard Information Dissemination Project” (or HazInfo Project) research findings, which were presented in the WG1: Human Perspectives and Service Concepts. The second paper titled “Wireless Mesh Networking – as a means of connecting rural communities was based on the design considerations of implementing the mesh network at Mahavilachchiya, Sri Lanka. Both papers were based on practical field level experiences. As a result they were well received by the audience and were inquisitive of the practical issues that sometimes defy the theoretical frameworks.

“Sharing Knowledge on Last-Mile Warning: Community-Based Last-Mile Warning Systems”: New Delhi, November 19, 2007

Attendees: Rohan Samarajiva, Nuwan Waidyanatha, Natasha Udu-gama

This report presents a summary of the “Sharing Knowledge on Last-Mile Warning: Community-Based Last-Mile Warning Systems” workshop which took place at the India Habitat Centre in New Delhi, India on 19 November 2007 from 9:30am - 4pm. The All India Disaster Mitigation Institute (AIDMI) and LIRNEasia jointly organized the workshop. This workshop proved to be an ideal venue for the dissemination of findings from the “Evaluating Last-Mile Hazard Information Dissemination” pilot project in India through an intimate gathering of practitioners, private sector, international organizations, local NGOs, and government.

7. The primary objectives were:

- Obtaining feedback on the findings of “Evaluating Last-Mile Hazard Warning Dissemination: A Research Project”,
- Exchanging lessons learned from end-to-end hazard detection and alerting systems that serve grassroots communities in India,
- Merging knowledge from India to develop practical solutions for communicating risk information to rural communities
- Analyze and determine methodologies for measuring the performance of Community-based Early Warning Systems
- Commencing dialogue on the development of a regional last mile warning system.

This workshop proved to be one in which the participants engaged well throughout the duration of the day’s proceedings. Participants showed great enthusiasm for the subject of

the workshop and the findings presented by LIRNE *asia*. The presentations and discussions were well on topic and discussions were fruitful and highly informative. As expected, discussion topics were not relegated to their individual sessions, rather, discussion on the overall topic of community-based early warning systems and the particular role of the HazInfo pilot project dominated all sessions.

Media attention was much higher than in the previous workshop in Bangladesh, due to having a public relations manager for this event. Press kits were prepared and distributed to journalists who joined the workshop proceedings throughout the day. Media outlets such as MINT publications (Wall Street Journal) and *Indian Express* were just some of the up to seven outlets that interviewed LIRNE *asia* on the HazInfo pilot project.

<i>Session Title</i>	<i>Presenter</i>	<i>Title and Comments</i>
Inauguration Opening Remarks	Mehul Pandya, Risk Reduction Transfer Initiative Coordinator, AIDMI, dmi@icenet.co.in , Natasha Udu-gama, udu-gama@lirne.net	
“Long Last Mile” Video Screening		The video provided a sound basis for the audience’s understanding of the workshop’s main topic, “Evaluating Last-Mile Hazard Information Dissemination” pilot project.
Opening Address: “Elements of a community-based warning system”	Dr. Rohan Samarajiva, Executive Director, LIRNE <i>asia</i> Samarajiva@lirne.net	Reviewed the basic elements of a community-based early warning system. The disaster cycle, early warning chains (standard vs. HazInfo), reasons for this type of system, overview of HazInfo results and

		implications for regionalization.
Session I – Methodology Preparedness, Training and Community Organization	P. Prasad Chief Consultant Welfare Organization for Rural Lean Development (WORLD)	“ICT Application in Community-Based Early Warning System”. Mr. Prasad gave an overview of natural hazards in Andhra Pradesh. His primary point was that WORLD has found a huge gap in the dissemination of hazard information from the <i>mandal</i> level to the villages despite wireless and other ICT communications systems available to the national and state level systems.
	Mr. Menake Wijesinghe, Program Director, Sarvodaya Community Disaster Management Centre Menake_Wijesinghe@yahoo.com	Discussion Sarvodaya’s role in the HazInfo project particularly in terms of formulation of methodology, participation in training, community organization and preparedness.
Session II – Transmission of Warning to Local Levels	Vijay Pratap Singh Aditya Ekgaon Technologies pvt. Ltd. vijay@ekgaon.com	Mr. Aditya gave a thorough overview of the communications policies governing dissemination of hazard information. He explained the key acts and policies and how and why they sometimes enable and disable appropriate hazard

		information dissemination to those that require the information most – the last-mile. He claimed that LIRNE <i>asia</i> and Sarvodaya would not be able to implement a pilot such as HazInfo in India because need for a strong interface with a local (governmental) institution.
	Natasha Udu-gama, LIRNE <i>asia</i>	“Transmission of Warnings to Local Levels: HazInfo Experience”. Outlined the differences between a traditional alerting system and HazInfo. Explained the HazInfo input applications and terminal devices, Common Alerting Protocol (CAP), Calculation of certainty and efficiency and results from HazInfo in determining the most effective methods for transmitting warnings to communities.
Session III – First Responder Action	Suresh Mariaselvam Coordination and Networking Associate Tamil Nadu Tsunami Resource Centre (TNTRC) suresh@tntrc.org	Gave an overview of TNTRC’s aid coordination and community capacity development in disaster risk management in Tamil Nadu. Explained the role of village

		information centers, community radio and ICT initiatives by sector in obtaining most effective “last-mile” connectivity.
	Natasha Udu-gama, LIRNE <i>asia</i>	“First Responder Action in HazInfo”. Explained “first responders” in the context of HazInfo then gave descriptions of first responder roles and methods of dissemination.
Session IV – Determination of Hazard from National Level	Nuwan Waidyanatha, HazInfo Project Manager, LIRNE <i>asia</i> Waidyanatha@lirne.net	“Determination of Hazard from the National Level: Sri Lanka Experience”. Drew comparisons on government action between Dec. 26, 2004 and Sept. 12, 2007 and described how the HazInfo pilot might help in structuring a national early warning system to be effective throughout the EWS chain.
	Dr. K.J. Ramesh, Advisor, Ministry of Earth Sciences, Government of India kj.ramesh@nic.in	-Push-through technology: Geneva Technologies works with WorldSpace Corp. to enable alerts to be sent in up to 24 languages. - 24 State government levels have a toll-free calling number
Session V: Next Steps	Dr. Rohan Samarajiva,	“Roles of policymakers,

	LIRNE <i>asia</i>	regulators, private sector and civil society”. Organizational problems must be solved for EW technologies to be fully realized. Early warning must be complemented by preparedness, evacuation plans, etc. Reiterated the need for the government to take the lead in providing early warning. Private sector and civil society can support and strengthen.
	Mehul Pandya, AIDMI	“Lessons for Early Warning from Tsunami Evaluation”. Discussed AIDMI’s role in the Tsunami Evaluation Coalition
	Mihir R. Bhatt Honorary Director All India Disaster Mitigation Institute (AIDMI) dmi@icenet.co.in	Discussed whether early warning is early enough or not. He then went on to talk on designing an early warning system and developing a strategy for an EW system saying that it must be an iterative process – an organization cannot have a prototype and just “do”, it must be simultaneous. Bhatt spoke of having a “pre-mortem” – declaring a failure prior to a

		launch of an early warning system.
--	--	------------------------------------

Media Coverage

- Press kits were prepared for up to 15 journalists that included copies of all the presentations and electronic copies of LIRNEasia's presentations.
- Several journalists joined the HazInfo workshop during its proceedings over the course of the day.
- Between 6-7 media interviews followed the workshop proceedings, including one for NDTV and a Hindi channel.
- Questions brought up by media:
 - Who is following through in India, where all the focus has been on hazard detection and monitoring?
 - Do you realize that getting such a system operational in India will be extremely complex because of center-state issues, etc.?
 - Are there plans to do a pilot in India?
 - Plans for more dissemination?

Summary

Like the HazInfo workshop in Dhaka, Bangladesh, the Indian workshop provoked much discussion on the use of technology in the “last mile” of an early warning system. Several small community-based organizations invited as speakers at the workshop, particularly TNTRC and WORLD, noted the use of village information centers and community radio in reaching the “last mile”. WORLD mentioned that the use of ICT has not breached the information gap between the *mandal* level and the village level. This signifies that though there is an acknowledgement of the use of ICTs to leverage greater participation at the “last mile”, the importance of training and active community participation has not been stressed enough. In comparison, HazInfo has not only stressed the usage of dual, complementing technologies (i.e. mobile and satellite radio) – complementary redundancy – but it has also highlighted the utmost importance of a comprehensive training regime with adequate inclusion of ICTs. The Indians were most receptive to the concept of complementary redundancy introduced by HazInfo. The number of early warning initiatives in India struck HazInfo researchers, mainly by the fact that many of them were unaware or had few ties to initiatives in other parts of the country. For a community-based early warning system to be successful, it will be crucial that various initiatives start meeting and working together. The HazInfo workshop has provided that meeting ground for these national initiatives, while

informing them of an international model (HazInfo) to optimize the use of technology and training within their systems.

“Sharing Knowledge on Last-Mile Warning: Community-Based Last-Mile Warning Systems”: Jakarta, Indonesia. March 5, 2008

Attendees: Rohan Samarajiva, Natasha Udu-gama, Nuwan Waidyanatha

A “Sharing Knowledge on Last-Mile Warning: Community-Based Last-Mile Warning Systems” workshop took place at the Hotel Borobudur in Jakarta, Indonesia in partnership with the Indonesian Institute for Disaster Preparedness (IIDP). The workshop provided an opportunity to discuss and share the findings of the “Evaluating Last-Mile Hazard Warning Dissemination: A Research Project” (HazInfo) with Indonesian counterparts while at the same time learning about similar initiatives and community-based hazard warning systems.

The primary objectives were:

- Obtaining feedback on the findings of “Evaluating Last-Mile Hazard Warning Dissemination: A Research Project”,
- Exchanging lessons learned from end-to-end hazard detection and alerting systems that serve grassroots communities in Indonesia,
- Merging knowledge from Indonesia to develop practical solutions for communicating risk information to rural communities
- Analyze and determine methodologies for measuring the performance of Community-based Early Warning Systems
- Commencing dialogue on the development of a regional last mile warning system.

OBSERVATIONS AND COMMENTS

Overall, the workshop went well despite earlier setbacks (i.e. planning for the workshop to be on 30 January, speakers dropping out at the last minute, etc.). IIDP did an excellent job in organizing the event in Jakarta and finding a range of speakers from government to community-based organizations.

The workshop began approximately 20 minutes late due to waiting for participants and some speakers. Workshop agendas were not printed and distributed prior to the event commencement, and when they were distributed the version was incorrect. Due to a late start, group discussion following each session had to be cut and put at the end of the workshop. This precluded asking questions on particular parts of the HazInfo research and their comparisons with the Indonesian experiences.

<i>Session Title</i>	<i>Presenter</i>	<i>Title and Comments</i>
Inauguration Opening Remarks	Ms. Chandra Lukitasari, Executive Director, IIDP Chandra.lukitasari@yahoo.com	Made some opening comments to participants and speakers including a brief introduction of LIRNEasia participants.
	Dr. Ir. Tatag Wiranto, MURP, Deputy Minister for Economic and Private Business Development and Chairman, Board of Advisors, IIDP. tatagwiranto@gmail.com	Gave opening remarks on the 4 th anniversary of IIDP's existence.
"Long Last Mile" Video Screening		The video provided a sound basis for the audience's understanding of the workshop's main topic, "Evaluating Last-Mile Hazard Information Dissemination" pilot project.
Opening Address: "Elements of a community-based warning system"	Dr. Rohan Samarajiva, Executive Director, LIRNEasia Samarajiva@lirne.net	Reviewed the basic elements of a community-based early warning system. The disaster cycle, early warning chains (standard vs. HazInfo), reasons for this type of system, overview of HazInfo results and implications for regionalization.
Aceh Tsunami Victims Testimonial	Ms. Titi Moektajasih, UNOCHA	Gave a brief overview of the impact of the 2004 tsunami in Aceh from a personal

**Session I
Methodology
Preparedness,
Training
Community
Organization**

– Jan Sopaheluwakan, Ph. D.,
Indonesian Institute of
Sciences (LIPI)

and

perspective.

Emergency Response to Community Preparedness”. Prof. Sopaheluwakan discussed the involvement of LIPI in monitoring and detection, warning and community preparedness. He noted that Indonesia is taking the lead on driving the process of early warning. It has been most interested in pushing preparedness, mitigation and response within community preparedness. He discussed 4 main elements of community-based early warning systems:

Risk knowledge

Monitoring of EW

Dissemination &
Communication

Response Capability (*Can*
people evacuate?)

There are 3 spheres:

Environmental -> ocean
monitoring

Social -> early warning

Economic -> tsunami
preparedness

LIPI does community
preparedness and public

education.

Prof. Jan discussed the National Framework developed by LIPI in conjunction with UNESCO and ISDR. He went on to explain the IOC-UNESCO end-to-end system. He introduced the audience to the LIPI “hourglass” concept where warning and emergency response meet at a critical point but are not mutually inclusive. He showcased lessons learned from the 2007 intervention and community expectation on TWS. To sum, he discussed challenges and recommendations noting that no agreements have yet been made at the national level.

Natasha Udu-gama, Discussion of the HazInfo
Dissemination Manager – project from the perspective
HazInfo, LIRNEasia [udu-
gama@lirne.net](mailto:udu-gama@lirne.net) of methodology,
participation in training,
community organization
and preparedness.

Session II – First Responder Action Mrs. Patra Rina Dewi, M.Sc., “Tsunami Early Warning
Executive Director, KOGAMI System: Lessons Learned
Padang from Padang City”. Mrs.
patrarinadewi@gmail.com Dewi gave a
comprehensive overview of

disaster preparedness in Padang, Sumatra. She mentioned that Padang was not affected by the 2004 tsunami but that the risk to both tsunami and earthquake is the highest in the world. Evacuation time in Padang is only 30 minutes. Early warning must be lightning fast to notify the densely populated city. She discussed an ideal Tsunami Early Warning System (TEWS) to meet the particular needs and concerns of Padang. Noted that electricity would be an issue for many technologies deployed for early warning (i.e. RA-Net). Current warnings and information from government is inconsistent and incomplete. She highlighted that education, particularly among children, is key to the success of early warning systems.

Nuwan Waidyanatha, Project Manager, HazInfo, LIRNEasia waidyanatha@lirne.net “Transmission of Warnings to Local Levels: HazInfo Experience”. Outlined the differences between a traditional alerting system

Session III – Mr. Aim Zein, Padang Advisor,
Transmission of GTZ - GITEWS
Warning to Local
Levels

and HazInfo. Explained the HazInfo input applications and terminal devices, Common Alerting Protocol (CAP), Calculation of certainty and efficiency and results from HazInfo in determining the most effective methods for transmitting warnings to communities.

“An Experience from Padang”. Mr. Zein noted that warning dissemination only allows for 10-20 minutes reaction time. Discussed the RDS (Radio Data System) and said that radio is most effective to override other technological deficiencies, particularly in Padang where at least one radio can be found in every house. Discussed RABAB, a local radio innovation, based on the need for guidance and information following a warning. RABAB is based on walkie-talkie information being transmitted by repeater to radio; either live or pre-recorded on FM 99.9. Current warning consists of

SMS only. Future warning system should be RAP1 (Citizen Band Radio Broadcast). Most in Padang are already aware of what to do in the event of an earthquake.

Drs. Sunarjo, MSc.
Kepala Pusat Sistem Data dan Informasi Geofisika, Bureau of Meteorology and Geophysics (BMG) Sunaryo@bmg.go.id

The BMG is responsible for the first 5 minutes of a disaster. Afterwards, other institutions are responsible. RA-Net has a 2-minute delay and is installed in more than 100 locations throughout Indonesia. They have SMS and radio dissemination systems – the technology used is more advanced than that of the GoSL. They say that the problem with SMS is the 150-character limit (CAP could solve this). There is also a tsunami siren network consisting of both federal and TELKOMSEL (largest national telecom provider) sirens. The local government is the one that decides to push the “button” or not. Since both police and army are deployed 24/7 the government works closely with them to be

**Session IV – Natasha Udu-gama, “Determination of Hazard
Determination of Dissemination Manager – from the National Level: Sri
Hazard from National HazInfo, LIRNEasia, [udu-
Level \[gama@lirne.net\]\(mailto:gama@lirne.net\)](mailto:udu-gama@lirne.net) Lanka Experience”.** Drew comparisons on government action between Dec. 26, 2004 and Sept. 12, 2007 and described how the HazInfo pilot might help in structuring a national early warning system to be effective throughout the EWS chain.

Dr. Ir. M. Dirhamsyah, Director, Tsunami and Disaster Mitigation Research Center (TDMRC), Syiah Kuala University, mdirham@yahoo.com

Dr. Dirhamsyah explained that an MoU has been signed with several other universities in February 2005 on coordination for early warning systems. He explained the TEWS framework, DRR framework (policy, non-structural and structural elements), the work of Syiah Kuala University in tsunami and disaster mitigation, their annual regional meeting in December and the DRR-A (Disaster Risk Reduction for Aceh) project.

Session V: Next Steps Dr. Rohan Samarajiva, Executive Director, LIRNEasia, samarajiva@lirne.net “Roles of policymakers, regulators, private sector and civil society”.

Organizational problems must be solved for EW technologies to be fully realized. Early warning must be complemented by preparedness, evacuation plans, etc. Reiterated the need for the government to take the lead in providing early warning. Private sector and civil society can support and strengthen.

Kusuma Adinugroho, Senior Programme Officer, Crisis Prevention and Recovery Unit, kusuma.adinugroho@undp.org Mr. Adinugroho as moderator gave brief summaries following each session. Here he gave a summary of points discussed throughout the workshop and their implications for Indonesia.

Discussion and Lessons Learned

The group discussion at the end of the workshop served to sum up the main points of the workshop. Mr. Kusuma Adinugroho of UNDP led the discussion by asking participants to review the questions posed in the workshop agenda and flesh out issues that had arisen during the workshop. Mr. Adinugroho made copious notes during the workshop so that group discussion turned out to be both interesting and fruitful.

What is the cost of the technologies used in the HazInfo pilot? [Nuwan Waidyanatha gave an approximate cost for each of the technologies]

Are communities still panicking despite disaster preparedness?

[Patra Rina Dewi, KOGAMI] Despite having many earthquakes in Padang, those that are uneducated and untrained still panic. However, children who have been trained and educated

tend to educate others.

[UNESCO] Since disasters can happen at any time there must be a disaster curriculum. The problem is the lack of education on disasters. There should be scheduled table-tops and/or drills, there should be good dissemination of technical knowledge and know-how. Despite having a national certification for training officials, trainers do not always have disaster management experience and expertise. This is essential.

Training:

[KOGAMI] Training must be culturally appropriate. The trainer must be able to adapt to the local culture. In some places KOGAMI can approach local government directly about these issues, but in other cases, it must first approach the religious/traditional leader of the community who would then approach the local government. Every school now has different Standard Operating Procedures (SOPs); SOPs must be standard throughout and is key to disaster risk reduction in communities.

[LIRNEasia] Since Sarvodaya trainers are young and oftentimes have difficulty getting through to village committees comprised mainly of elderly females, they train through asking pertinent questions. Other problems faced by trainers include caste differences. HazInfo is highly context specific; local knowledge in communities is of the utmost importance. However, in some cases, where communities requested certain items like loudspeakers, neither the item nor money was given. Communities had to figure out how to disseminate with the resources in existence.

[IIDP] Does community-based training exist for communities in Padang?

[KOGAMI] Still in process. Only 35% completed so far, but optimistically this will be completed in the long run. Religious leaders play a very important role in making decisions.

How many people are ready to accept EW systems?

[GTZ] BMG sends messages to first responders, etc. and others interested.

[University of Surabaya] In East Java, mountains are erupting. The government gives warning but some people are refusing to evacuate. There is rampant distrust of government because of the number of false warnings. High tech. vs. local warning systems is also an issue.

[UNESCO] Emphasize education. It is impossible to change the paradigm within local societies entirely. There are many false warnings in Indonesia because the Gol shares information, but warnings are not fully developed.

[KOGAMI] Police and army should have similar approaches to DRR regarding specific scenarios.

Currently, how long does warning reach communities?

[KOGAMI] SMS = 5-7 minutes; when electricity goes out the TV is useless

[Syiah Kuala] In Aceh, when warning was given there was no information at all.

Recommendations to the Organizers

- Presentations must be received prior to workshop commencement. This has been an ongoing problem; speakers must be forced to take the workshop seriously.
- Workshop documentation, such as programs, must be printed and distributed prior to the onset of the workshop.
- Coordination with partner organization needs to be improved. There must be a reliable contact who will keep documentation received updated and share necessary documents.
- Ensure that the partner organization is equipped with necessary technical equipment (such as computer, recorder, etc.) for timely and accurate proceedings.
- Start the workshop at a later time. Nine o'clock start times are difficult in several parts of Asia.
- Having one moderator in this workshop turned out to be more efficient. It is best to have a moderator who is not a speaker but experienced in the subject matter.

GK3 Session ET4: Emerging Technologies Session on "Making Communities Disaster Resilient": Kuala Lumpur, Malaysia. December 11, 2007

Attendees: Rohan Samarajiva, Nuwan Waidyanatha, Natasha Udu-gama, Vinya Ariyaratne (Sarvodaya), Michael De Soya (Dialog Telekom), Mala Rao (WorldSpace)

The ET4: Emerging Technologies Session on "Making Communities Disaster Resilient" took place on 11 December from 16:00 to 17:30 at the Kuala Lumpur Convention Center in Kuala Lumpur, Malaysia. The session addressed how an alliance of civil society and private sector organizations since the 2004 Indian Ocean tsunami have been striving to develop a robust solution for strengthening community resilience in the face of natural disasters. Efforts have ranged from technological innovation, such as remotely activated warning devices, to field simulations. Initiated pilot projects can now provide real data to support implementation.

Panelists shared learning for regional scaling-up of these pilots through discussion, videos and actual equipment demonstrations. The pilots highlighted were the satellite radio from

WorldSpace and the GSM-based warning device developed by Dialog Telekom, University of Moratuwa and MicroImage.

This session addressed the following key questions:

- What would be the new thinking on private supply of public goods, new technologies and novel forms of community involvement?
- How can the essential public good of hazard warning be produced in adequate quantities and quality?
- Why do governments appear to have other priorities? How can communities organize themselves to become disaster resilient?
- How can the Common Alerting Protocol (CAP) be successfully implemented in a multi-technology, multi-language, multi-country environment like the Bay of Bengal region?

Panelists included:

- Vinya Ariyaratne, Executive Director, Sarvodaya Shramadana Movement of Sri Lanka
- Natasha Udu-gama, Former Consultant, Sarvodaya Community-based Disaster Management Centre / HazInfo Project Dissemination Manager, LIRNEasia
- Nuwan Waidyanatha, Project Manager, LIRNEasia
- Mala Rao, Manager Closed User Group Solution, WorldSpace Corporation (India)
- Michael De Soyza, Senior Manager, Corporate Responsibility and Public Policy, Dialog Telekom PLC

Moderator:

- Rohan Samarajiva, Executive Director, LIRNEasia

***CPRsouth2 “Empowering rural communities through ICT policy and research”:
Chennai, India, December 15-18, 2007***

Attendees: Rohan Samarajiva, Nuwan Waidyanatha, Natasha Udu-gama

The HazInfo project was presented during session 5 “National and Regional Innovation Systems” on December 15, 2007. Nuwan Waidyanatha presented his paper on “Last-Mile Hazard Warning System in Sri Lanka: Performance of the ICT First Responder Training Regime” and Natasha Udu-gama presented her paper on “A Last-Mile Hazard Warning System for disaster risk reduction in Sri Lankan villages: Community organization”.

Nuwan Waidyanatha’s paper explained that the Sri Lankan experience shows that the LM-

HWS is neither efficient nor effective without competent human capacity at the message-relays: Hazard-Information-Hub and Last-Mile Communities; a necessary condition to supplement the deficit of an end-to-end automated alerting system. Despite the training that was offered to the Hazard-Information-Hub Monitors and Community ICT Guardians; their performance was well below the 95% benchmark. The project identifies that the Common Alerting Protocol intensive ICT based last-Mile alerting and notification system requires periodically repeated training and certification to improve the reliability and effectiveness of the human resources who are entrusted with mission critical LM-HWS processes.

Natasha Udu-gama's paper discussed the hypothesis during the pilot phase that purported Sarvodaya level 4 villages would use and perform better with the ICTs than levels 1-3. Evidence found through the pilot demonstrates the congruity between highly organized communities and a better understanding and adoption of wireless technologies. It addressed why community organization is significant to Sarvodaya and the HazInfo project within the context of disaster risk reduction, preliminary findings from the pilot supporting this argument, and policy recommendations for stakeholders.

GK3 Session Paper – “Promoting Community Disaster Resilience through Technology, Training and Community Empowerment: The HazInfo Experience”

GK3 organizers asked that a session paper be prepared for the “Making Communities Disaster Resilient”. The session paper entitled “Promoting Community Disaster Resilience through Technology, Training and Community Empowerment: The HazInfo Experience” discussed the main themes of community and technology defining HazInfo that have contributed to the success of the pilot and ways in which the expansion of the project may contribute to sustainability and disaster resiliency at the community level while utilizing appropriate information communication technologies (ICTs).

CPRsouth2: Empowering rural communities through ICT policy and research IIT-Madras, Chennai, India; December 14-18, 2007

Session 5 – National and regional innovation systems

Attendees: Natasha Udu-gama, Nuwan Waidyanatha

This session was chaired by Prof. Myeong Cheol Park (South Korea) and the discussant was Prof. Harmeet Sawhney (USA). Three papers were presented by Nuwan Waidyanatha (Sri Lanka) on ‘Last-Mile Hazard Warning System in Sri Lanka: Performance of the ICT First

Responder Training Regime', Natasha Udu-gama (Sri Lanka/USA) on 'A Last-Mile Hazard Warning System for disaster risk reduction in Sri Lankan villages: Community organization', and Bernard Francis Chogi (Kenya) on 'The impact of mobile phone technologies on Medium and Small Enterprises/Jua Kali (MSEs).'

Nuwan Waidyanatha's presentation on the Last-Mile Hazard Warning System (LMHWS) in Sri Lanka focused on the lessons learned during the pilot phase of the project, which established the networking capability for 30 tsunami-affected communities with a heterogeneous deployment of five ICTs. One of the key lessons was the fact that the LMHWS was neither efficient nor effective without competent human capacity at the message-relays, a necessary condition to supplement the deficit of an end-to-end automated alerting system. Nuwan's presentation showed that despite their training, the 'First Responders' performance was well below the 95% benchmark.

The presentation made by Natasha Udu-gama, on the same test case described above by Nuwan, provided insight into the organizational aspects of the pilot. Natasha's study provided evidence that demonstrated the congruity between highly organized communities and a better understanding and adoption of wireless technologies deployed. The presentation also addressed why community organization was significant to Sarvodaya and the HazInfo project within the context of disaster risk reduction, the preliminary findings from the pilot supporting this argument, and policy recommendations for stakeholders.

Francis presented the findings of a survey conducted in Nairobi, Kenya, which looked at the socio-technical dimension of using mobile phones in micro and small enterprises (commonly referred to as jua kali businesses), and the socio-economic impacts it had on the urban micro entrepreneurs in Kenya. The study also discussed the various ways in which mobile phones had transformed the micro enterprises in Nairobi.

Discussant Prof. Sawhney believed that a more comprehensive literature review should have been carried out with regard to the two disaster management papers; he was also of the opinion that the papers presented in this session were not ready for journal publication yet.

IDRC's Regional Director for South Asia and China Stephen McGurk said that he was doubtful of Sarvodaya's role and contribution to the Last Mile project; he explained that more

discussion needed to be made on their contributions to the project as well as how the pilot will continue. Another participant questioned how Last-Mile project contributed to sustainability.

HazInfo Documentary: “The Long Last Mile”

“The Long Last Mile” video documentary, produced by TV-E Asia-Pacific, for LIRNE *asia* was completed in October 2007. The video features Sarvodaya footage from the pilot project; excerpts of interviews with Dr. Rohan Samarajiva, Executive Director – LIRNE *asia*, and Dr. Vinya Ariyaratne, Executive Director – Sarvodaya; and, a thorough synopsis of the methodology and technologies tested and deployed during the pilot.

HazInfo DVD Distribution

“The Long Last Mile” DVD was distributed to fifty-three (53) partners and organizations in the early warning and disaster risk reduction fields all over the world. A list of these partners and organizations can be found in Appendix B.

Conference Papers Accepted, Not Attended:

4th International Conference on Information Systems for Crisis Response and Management (ISCRAM) – Delft, 13-16 May 2007

The HazInfo paper on CAP titled “Hazard Warnings in Sri Lanka: Challenges of Internetworking with Common Alerting Protocol” has been published in the ISCRAM proceedings. The conference took place from 13-16 May 2007 in Delft, The Netherlands. The final program of the 4th International Conference on Information Systems for Crisis Response and Management available on their website. It contains the complete program, including the abstracts of all papers and presentations. Conference was held at the Technische Universiteit Delft.

Wireless Personal Multimedia Communications (WPMC) Conference: Jaipur, India. 3-6 December 2007

The HazInfo paper titled “Last-Mile Hazard Warning in Sri Lanka: Performance of WorldSpace Satellite Radios for Emergency Alerts”, coauthored by Srinivasan Rangarajan, PhD (Senior Vice President Engineering, WorldSpace), Peter Anderson (Associate

Professor, Simon Fraser University), Gordon Gow, PhD (Assistant Professor, University of Alberta), and Nuwan Waidyanatha (Project Manager, LIRNEasia) was accepted for oral/poster presentation at the Wireless Personal Multimedia Communications (WPMC) at The Birla Science and Technology Center in the heart of Jaipur, India, December 03 – 06, 2007.

WorldSpace, a lead technology partner in the HazInfo research project, field-tested 16 Addressable Radios for Emergency Alerts (AREAs) in the Sarvodaya Communities and 34 AREAs in the Sarvodaya District Centers. Although the AREA solutions lacked bi-directional communication and seemed the least effective, the AREA solution proved to be the most reliable that worked with utmost certainty and greatest efficiency even when GSM and CDMA cells were deactivated for over 2 months, at the beginning of this year, during military operations in the conflict prone North-East regions of Sri Lanka. The HazInfo research introduced a concept called “complementary redundancy”, where coupling the AREA addressable/broadcast technology with a GSM mobile phone or CDMA nomadic phone improves the overall performance (reliability and effectiveness) of the HazInfo system. The HazInfo system was used in a “live” scenario during the Bengkulu earthquake on September 12th.

Future Conferences/Workshops:

International Conference on Earthquake Engineering and Disaster Mitigation 2008 (ICEEDM): Jakarta, Indonesia, 14 April 2008

Title: “Community-based Hazard Warning in Sri Lanka: Performance of the Last-Mile Link”.

Author(s): Nuwan Waidyanatha, Peter Anderson, Gordon Gow

Media Coverage:

Print –

“Disaster Alert”, DataQuest India. 31 December 2007 Online:

<http://www.lirneasia.net/2008/01/hazinfo-project-featured-in-dataquest-india/>.

Dole, Nilma. “Radio Messages to Warn of Natural Disasters”. *Sunday Observer*. 30 December 2007. Online: <http://www.sundayobserver.lk/2007/12/30/new17.asp>.

“Sri Lanka tested satellite disaster warning system to be used in India”. *The Sinhala News Agency*. 28 December 2007. Online: <http://www.sinhalaya.com/news/english/wmview.php?ArtID=14500>.

“Sri Lanka tested satellite disaster warning system to be used in India”. *Lanka Business Online (LBO)*. 27 December 2007. Online: http://www.lbo.lk/fullstory.php?newsID=2122122686&no_view=1&SEARCH_TERM=10.

“AREA Ready for Deployment”. *Satellite TODAY*. 27 December 2007. Online: <http://www.satellitetoday.com/st/headlines/21805.html>.

SatNews.com. Online: http://www.satnews.com/cgi-bin/display_story.cgi?number=1117881731.

Wattegama, Chanuka. “A Tale of Two Tsunamis: What Went Wrong in Each Case”. *Daily Mirror*. 26 December 2007. Online: http://www.dailymirror.lk/DM_BLOG/Sections/frmNewsDetailView.aspx?ARTID=2220

“New disaster warning technology on anvil”. *The Times of India*. 16 December 2007. Online: http://timesofindia.indiatimes.com/India/New_disaster_warning_technology_on_anvil/articleshow/2625862.cms.

“Tsunami: Need for early warning systems underscored”. *The Daily Star*. 2 October 2007. Online: <http://www.thedailystar.net/story.php?nid=6270>.

TV –

Interview with Natasha Udu-gama. Astro Awari Cable Television (Malaysia). 11 December 2007. Hosted by Kamurul Bahrin Haron.

Interview with Rohan Samarajiva and Dr. A. T Ariyaratne. Channel One (MTV). *Biz First*. Hosted by Harsha De Silva. 26 December 2007

7. Capacity-building

The HazInfo supplemental workshops enabled LIRNE *asia's* original HazInfo project to extend its reach beyond Sri Lanka, where it was originally piloted. It has helped the organization strengthen its ties with disaster risk reduction-related university departments, research and implementing organizations. In Sri Lanka it has sparked interest within the Ministry of Disaster Management and Human Rights (MDMHR) to gather a committee of telecom providers to design a mobile solution for an effective public warning system. The Bangladesh workshop at the Bangladesh University of Engineering and Technology encouraged sufficient interest for the civil engineering department to want to replicate the project given Bangladesh's particular hazard vulnerabilities. Upon completion of the workshop in New Delhi, India, the host (All India Disaster Mitigation Institute) developed a proposal suggesting that HazInfo be disseminated as a "road tour" to four major Indian cities that are particularly vulnerable to a variety of hazards.

The GK3 session on "Making Communities Disaster Resilient" was a panel discussion involving the various stakeholders involved in the HazInfo project. Each gave a short description of their organization's role in the project and the lessons learned they gained from it. The session speakers were slightly more representative gender-wise given the venue and its particular attention to attracting minority representation.

The HazInfo workshop in Indonesia was significant in that it was the only one that was organized by a predominantly female disaster risk reduction organization. Unlike earlier workshops, the participation of women was at its highest, including among speakers.

8. Project management

HazInfo supplemental project management during the six-month period was generally good. Administration was done mainly by the dissemination manager for HazInfo with financial support and expertise provided by LIRNE *asia's* finance department. Technical oversight and scientific input for workshop organization and presentation design was done by both dissemination manager and HazInfo project manager. Most of this work was done virtually as the project manager is in a satellite location.

IDRC support and administration was conducted directly from its main office in Ottawa. Throughout the duration of this supplemental, interaction with Ottawa was minimal.

Administrative matters included the signing of an amendment to the original contract (for the supplemental) in August and last month, request for a no-cost extension to the HazInfo supplemental to take into account changes in the schedule for the Indonesia workshop. All interactions with IDRC regarding technical support and administration went smoothly.

9. Impact

The dissemination of the HazInfo pilot project throughout nations in the region will have a profound effect on the development of early warning systems. Until now, most of the thinking in developing sound early warning systems has focused primarily upon robust technology. Monitoring and detection technologies, especially, have garnered much of the attention. This dissemination sought to educate academia, government, NGO/INGO, research, private and civil society organizations working within the field about the necessity of a community-based last-mile early warning system and the availability of technologies that would be best-suited for relaying alerts/warnings to educated and aware community members within the HazInfo pilot. HazInfo supplemental dissemination reached a level of society already knowledgeable about the basics of early warning, but not necessarily those that had worked or researched the impact of specific technologies in relaying understandable alerts to trained members of a community at-risk.

The series of workshops and additional events mainly influenced various stakeholders – from policymakers and NGOs to researchers and practitioners. The two dissemination workshops held in India and Bangladesh had more reach, rather than pure influence, than other events attended. Specifically, at the Bangladesh workshop, one of the speakers – a professor at BUET – had (at the time of the workshop) already expressed an interest in replicating the HazInfo project within the context of Bangladeshi disaster vulnerability. The Bangladeshi pilot is currently in the process of being developed with WorldSpace AREA receivers in process and pilot commencement scheduled for the end of February 2008. In regards to HazInfo's reach in India, LIRNE*asia's* partner organization, AIDMI, responded so favorably to the HazInfo presentations in Delhi that it suggested that dissemination of HazInfo findings should extend to other major India cities through a "road tour" workshop to 4 major vulnerable Indian cities. Since the Indonesia workshop has just completed [at the time of this report], the reach has yet to be ascertained. The affiliated HazInfo supplemental events within the region (and in Rome) were highly influential in educating academics, researchers and practitioners on

various aspects of the HazInfo project. It is expected that through contact with several community-based organizations through the HazInfo dissemination workshops in Bangladesh, India and Indonesia, marginalized social groups such as women, minorities, poor and disabled will derive optimum benefits since these organizations will comprehend and implement ideas garnered from lessons learned in the HazInfo pilot.

10. Overall assessment

The dissemination of the “Evaluating Last-Mile Hazard Information Dissemination” pilot project through the supplemental agreement was important on a number of levels:

1. **Provision of knowledge to the field of community-based early warning.** The HazInfo pilot is on the cutting-edge of hazard early warning systems in that it recognizes the ability of communities to make decisions on its vulnerability to disaster based on a trusted and recognized source of information through appropriate technology. Prior to this project, few had explored the appropriateness of technology within a “last-mile” community-based early warning system as a part of a national early warning system. Thus, the dissemination of HazInfo within the region was vital to expressing its unique findings and contributing to the development of sound, responsible early warning systems. Time, effort and funding towards this purpose were highly effective.
2. **Congregation of national experts in three nations for regional cooperation on community-based early warning.** HazInfo was quite effective in garnering the necessary interest from disaster management stakeholders though the pilot was administered by a research organization specializing in telecommunications. Not only did disaster reduction and response organizations respond favorably, but so did government, academia, NGO/INGO and civil society. Moreover, HazInfo succeeded in bringing these various actors together in national workshops for discussion on contributions of community-based early warning systems to national early warning systems as well as regional early warning.
3. **Promotion of cooperation amongst region on community-based early warning initiatives.** Although workshops were conducted in the three individual Bay of Bengal nations, LIRNE *asia's* organizational regional focus has promoted a regional view of community-based early warning; how organizations at the grassroots level may be able to influence policy through substantial evidence on usage of technology and training in providing an effective solution to early warning systems by incorporating community.
4. **Advocacy of HazInfo findings amongst government officials.** HazInfo has

repeatedly been showcased to government so as to demonstrate the benefits of community-based early warning systems within the national public warning system. Building upon one-on-one organizational interactions with the Ministry of Disaster Management and Human Rights (MDMHR), the September 7, 2007 meeting with telecom providers and operators was a significant step in coordinating and advising telecom providers about their potential contribution to early warning. Although provisions were made to initiate a working committee to outline and provide a solution to the issuance of public warning through the use of cell broadcasting, no further action has since been taken. However, LIRNE *asia* continues to lobby and discuss the issue with the MDMHR through sharing of the HazInfo dissemination paraphernalia and activities.

11. Recommendations

With the conclusion of the HazInfo supplemental on 31 March, 2008, there are a number of recommendations that can be made based on this extension as well as the original HazInfo project.

- ***Dissemination of HazInfo should go beyond national workshops to a regional workshop.*** A regional workshop would enhance both the reach and influence HazInfo can have on development of an early warning system(s) that account for the last-mile and are community-based.
- ***Expansion of HazInfo national workshops.*** Workshops should be held in other countries within the region, not just the Bay of Bengal region.
- ***Encourage a HazInfo Workshop “Road Tour”.*** This “road tour” concept was proposed to LIRNE *asia* from its HazInfo workshop partner in India, AIDMI. Basically, it would be a traveling group of HazInfo experts and affiliated experts who would conduct workshop/demonstrations in several other major (Indian) cities at-risk in more public venues targeting more than just other experts, researchers, policymakers and regulators. The goal would be to mainstream the concept of “last-mile” community-based early warning systems with other community-based NGOs as well as the general public.
- ***Provide support for an Internet database on “last-mile” early warning systems.*** Currently, a comprehensive database on projects/initiatives in this area is lacking. Not only would such a website, feature HazInfo, it would also enable greater cooperation and coordination of existing projects towards a more meaningful and substantial regional workshop should one be held. Eventually, this may enable “last-mile” emergency telecommunications to influence existing regional early warning systems (i.e. IOTWS).

Appendix A: Proposed Participants for HazInfo Indonesia Workshop

Proposed participants include:

- BAKORNAS PB-National Disaster Management Coordination or its replacement
- BMG Bureau for Meteorology and Geophysics
- Indonesian Institute of Sciences- LIPI
- BPPT-National Board for Development and Application of Technology
- Directorate General of Geology
- Directorate of Vulcanology
- Government Institutions related to the community preparedness:
 - Directorate General of Social Protection, Ministry of Social Affairs
 - Directorate General of Social Assistance, Ministry of Social Affairs
 - Directorate General of Social Empowerment, Ministry of Social Affairs
 - Directorate General of Community Empowerment of Ministry of Home Affairs (MOHA)
 - Directorate General of Governance Affairs, Directorate of Disaster Management, MOHA
 - Directorate of Community Protection and Nation Unity, MOHA
- Ministry of Public Works
- Ministry of Health
- Ministry of Education

- Ministry of Environment
- Ministry of Energy and Mineral Resources
- Ministry of Women Empowerment

Universities having faculty or research institute or Section on disaster management:

- Center of studies for disaster - Gadjahmada University, Yogyakarta
- Center of Studies for earthquakes- Institute of Technology of Surabaya
- Center of Studies for conflict and disaster mitigation- Tadulako
- University-Palu, Central Sulawesi
- Center Study of disaster-Bandung Institute of Technology-West Java
- Faculty of Disaster Management-University of Krishna Dwipayana-Jakarta
- University of Jember- East Java
- University of Malang-East Java
- University of Syiah Kuala-Aceh
- University of Indonesia-Jakarta
- CARE IPB, Institute of Agriculture of Bogor-West Java

NGO and UN Agencies:

- CRS
- CARE
- OXFAM
- MPBI
- Community Association of Merapi Mountain (Sabuk Gunung Merapi-related to volcanic eruptions)
- Local NGO of East Java (take care of hot mud flow)
- Local NGO of Padang (take care of earthquake Bengkulu and West Sumatra)
- Local NGO of Aceh (take care of Tsunami in Aceh/Nias)
- UN-OCHA
- UNDP
- UNICEF
- UNESCO

Grant No. 103553-001

Report Submitted: March 01, 2008

Appendix B: Distribution of HazInfo DVDs

“The Long Last Mile” has been distributed to the following partners/organizations:

1. Dr. Mehedi Ahmed Ansary, BUET
2. Dr. S. Rangarajan, WorldSpace
3. AJJDC
4. Dr. Vinya Ariyaratne
5. All India Disaster Mitigation Institute
6. Tamil Nadu Tsunami Resource Centre
7. Prof. Pete Anderson, Simon Fraser University
8. Dr. Gordon Gow, University of Alberta
9. GK3 South Asia Pavilion
10. Government of Maldives
11. Vijay Pratap Singh Aditya, Ekgaon Technologies
12. GK3 “Making Communities Disaster Resilient” session participants
13. Mr. Michael De Soyza, Dialog Telekom
14. Ms. Mala Rao, WorldSpace
15. Dr. Lareef Zubair, IRI – Columbia University
16. Dr. Kathleen Tierney, Natural Hazards Center, University of Colorado
17. Mr. Sanjana Hattotuwa
18. Prof. Dr. Sudhir K. Jain, Dean & Professor, IIT-Kanpur
19. Mr. Terry Jeggle, UNISDR
20. Dr. A. S. M. Maksud Kamal, UNDP-CDMP, Bangladesh
21. Mr. Mostafa Kamal, Bangladesh
22. Mr. Ravi Kandage, Director – Shanthi Sena, Sarvodaya
23. Mr. Samerendra Karmaker, BMD, Bangladesh
24. Mr. Shisir Khanal, Executive Director, Sarvodaya USA
25. Mr. Spiros Konstantakos, IDEP, Indonesia
26. Dr. Frederick Krimgold, Director – DRR, Virginia Tech, USA
27. Mr. Rahul Kumar, WorldSpace India
28. Mr. Barjor Mehta, World Bank
29. Mr. Mehrun Nessa, SPARSSO, Bangladesh
30. G. Padmanabhan, UNDP, India
31. UNISDR, Switzerland
32. UN-ISDR, Platform for the Promotion of Early Warning, Germany
33. Ms. Meenakshi Ahluwalia, UNDFW, India
34. Ms. Wahida Bashar Ahmed, Action Aid Bangladesh
35. Monowar Hussein Akhand, Ministry of Establishment, Bangladesh
36. Dr. Nihal Attapattu, Canadian High Commission, Sri Lanka
37. Dr. B. K. Bandyopadhyay, IMD, India
38. Mr. Teddy Boen, Earthquake Engineer, Indonesia
39. Ms. Zoe Chafe, Worldwatch Institute, USA
40. Shri G. M. Dar, J & K Institute of Management, India

41. Prof. Dileeka Dias, University of Moratuwa, Sri Lanka
42. Mr. Laurent Elder, IDRC, Canada
43. Mr. Theo Fernando, ICET, Sri Lanka
44. Mr. Michael Renner, Institute for Environmental Security, USA
45. Mr. Satya Sagar, India
46. Jean Slick, Canadian Red Cross, Canada
47. Mr. Man Thapa, DRR Advisor, UNDP, Sri Lanka
48. Dr. John Twigg, Benfield UCL Hazard Research Center, UK
49. Major General Gamini Hettiarachchi, Director General, Disaster Management Centre, Sri Lanka
50. Dr. Ananda Mallawatantri, Asst. Resident Rep., UNDP Sri Lanka
51. Dr. Cosmos Zavazava, Head, BDT, ITU, Switzerland
52. Mr. Md. Nasir Ullah, Director, CPP, Bangladesh Red Crescent Society
53. Mr. Kamaruzzaman, Program Coordinator, BNNRC, Bangladesh