

FACTA UNIVERSITATIS

Series: **Mechanical Engineering** Vol. 12, N° 2, 2014, pp. 149 - 155

Original scientific paper

A REAL TIME NEURAL NETWORK BASED FINITE ELEMENT ANALYSIS OF SHELL STRUCTURE

UDC 519.95:531.2

**Žarko Čojbašić, Vlastimir Nikolić, Emina Petrović,
Vukašin Pavlović, Miša Tomić, Ivan Pavlović, Ivan Ćirić**

Mechanical Engineering Faculty, University of Niš, Serbia

Abstract. *In recent years, the finite element method has been widely used as a powerful tool in the analysis of engineering problems. In the simulation of deformable objects using the finite element method, a complex system of nodes which make a mesh grid is used. The FEM model includes material and structural properties, which altogether determine the model's response to certain loading conditions. A reliable simulation is supposed to provide for an easier, faster and less expensive development of structures. The real-time simulation of shell-type deformable objects using the finite element method for a non-linear analysis is a challenging task because of the need for fast systems that do not demand high computational cost. In this paper, we present an efficient method based on neural networks for simulating the real-time behavior of a thin walled structure modeled by the finite element method in the commercial FE software. Using the finite element method, the structures displacements are computed offline, by applying forces in the specified range. In the online application mode, a trained neural network is used for obtaining required results for specified loads.*

Key Words: *Finite Element Analysis, Neural Network, Simulation, Thin Walled Structure, Shell*

1. INTRODUCTION

The finite element method (FEM) rapidly grew as the most useful numerical analysis tool in the mechanical engineering disciplines (such as aeronautical, biomechanical, and automotive industries). The FEM provides for detailed visualization of where structures deform and indicates the distribution of stresses and displacements. Continuous development of new structural materials leads to ever increasingly complex structural

Received March 18, 2014 / Accepted July 2, 2014

Corresponding author: Žarko Čojbašić

University of Niš, Faculty of Mechanical Engineering, Department for Mechatronics and Control of MEF, Aleksandra Medvedeva 14, 18000 Niš, Serbia

E-mail: zcojba@ni.ac.rs

designs that require a careful analysis [1]. The utilization of numerical methods to solve shell mathematical models of complex structures has become an essential component in the design process [2]. Thus, the finite element method has been widely used as the fundamental numerical procedure for the analysis of shells [3]. In order to improve the performance and for optimization purposes, which play an important role in design process and modeling, integration of the finite element method and the neural networks has been considered by some authors. Such integration enables a simulating real-time behavior of the structure; it allows the response of a structure in real or nearly real time to external stimuli to be observed. To illustrate the computational methodology Javadi et al. [4] have presented three numerical examples of application of the developed intelligent finite element code (named NeuroFE program) to engineering problems. A neural network is trained using data representing the mechanical response of the material to applied load; the trained network is then used in the finite element analysis to estimate the stress and displacement. An application of the Artificial Neural Networks for definition of the effective constitutive law for a composite is considered in [5]. First, a classical homogenization procedure is directly interpreted with the use of this numerical tool. Next, a self-learning Finite Element code (FE with ANN inside) is used in the case when the effective constitutive law is deduced from a numerical experiment (substituting here a purely phenomenological approach). In [6], a combination of the nonlinear contact finite element analysis and the artificial neural network has been applied to explore the possibility of material property execution with automatic ball indentation.

This paper addresses the need for a fast system that simulates real-time behavior of shell structures. The main idea in this paper is to combine available tools, namely the finite element method and the neural networks in order to provide for a new quality. In the proposed methodology, the neural network is used for faster and easier obtaining of required results for specified loads. It is trained by using the raw numerical data obtained by the finite element method, representing the displacement of the structure to applied load.

2. MODELING OF SHELL STRUCTURE

The recognition of the nature of the global behavior of thin-walled structures allows condensation of the complex 3D-field to the essential ingredients of the structural response described by a 2D approach, and thereby an efficient modeling of such structures is achieved. A general shape implies arbitrarily curved structures. Irrespectively of the applied loads, both the membrane and the flexural strains are induced in such a structure. Furthermore, the thin-walled structures made of composite laminates require 2D-theories with transverse shear strains and stresses included for adequate modeling. The simplest and most frequently used theory is the First-order Shear Deformation Theory (FSDT), which is based on the Mindlin-Reissner kinematical assumptions that imply constant transverse shear strains and stresses across the thickness of the structure [7].

Within the framework of the FEM, the strain field of a shell element based on the aforementioned kinematical assumptions is given in the following general form:

$$\{\varepsilon\} = \begin{Bmatrix} \{\varepsilon_{mf}\} \\ \{\varepsilon_s\} \end{Bmatrix} = \begin{Bmatrix} [B_{mf}] \\ [B_s] \end{Bmatrix} \{d_e\} = [B_u] \{d_e\}, \quad (1)$$

where $\{\varepsilon_{mf}\}$ and $\{\varepsilon_s\}$ are membrane-flexural (in-plane) and transverse shear strains, respectively, $[B_{mf}]$ and $[B_s]$ are corresponding strain-displacement matrices and can be summarized into element strain-displacement matrix $[B_u]$, and, finally, $\{d_e\}$ are element nodal displacements. For more details on the definition of the strain field, an interested reader is referred to [8].

3. MODELING AND ANALYSIS OF CYLINDRICAL ARCH STRUCTURE

Fig. 1 shows a shell that is analyzed in this paper. A simply supported cylindrical arch with radius $R=360$ mm, central angle 112.5° , and width $b=700$ mm is considered. The thickness of shell is 30 mm. A uniform mesh is used in this solution. Number of elements is 196 (14×14), while type of elements is a quadrilateral shell element with 8 nodes.

The type of analysis performed to determine displacements of this structure in the shape of cylindrical arc is non-linear. This type of analysis provides for more accurate results, but it increases computation time, even for this simple shape structure.

The considered structure is exposed to rather large loads and, hence, the induced deformations exceed the realm of linear analysis. Therefore, the geometrically nonlinear FEM analysis is applied to determine the structural response with adequate accuracy. This, furthermore, implies increased computational time because the structural stiffness continuously changes over the course of deformation as a consequence of the change in structural configuration and stress state. The incremental solution procedure based on the iterative Newton-Raphson method is used to obtain the solution.

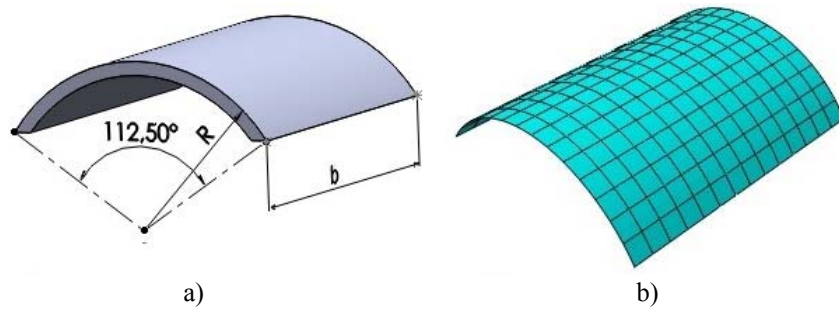

Fig. 1 a) Cylindrical arch with boundary conditions, b) meshed shell

The excitation is modeled as a concentrated force with components in x- and y-directions. The range of applied forces is 0.3 MN to 4.6 MN in x-direction, and 0.6 MN to 9 MN in y-direction, which results in structural deformation.

Fig. 4 depicts the shell deformations at different loads obtained in the ABAQUS. The deformations are given with the scaling factor equal to 1, i.e., the real deformation is depicted. The lower part of the figure shows rather large deformations that definitely require nonlinear computation.

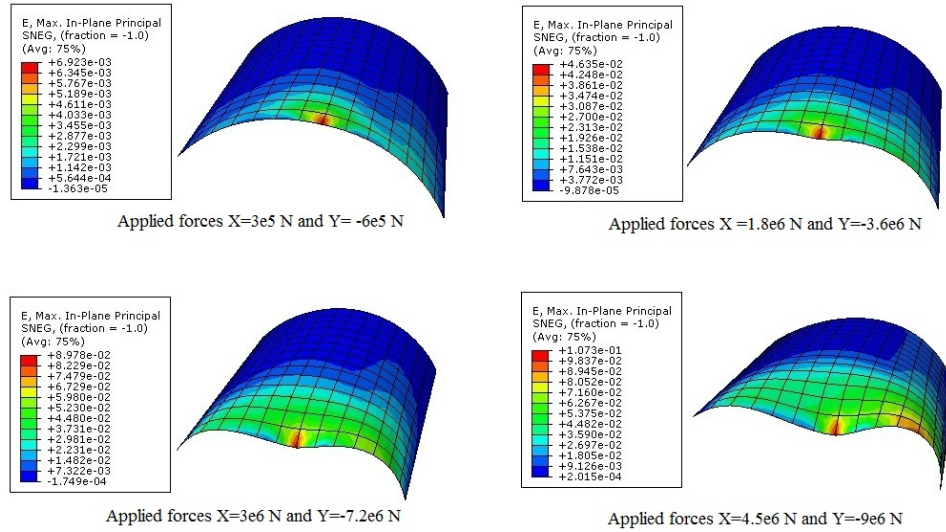

Fig. 2 The shell displacements at different loads

4. A REAL TIME NEURAL NETWORK-BASED FINITE ELEMENT ANALYSIS

A standard feed-forward, back propagation neural network is used in this study. To provide for an efficient solution, the artificial neural network (ANN) [9] has three layers: an input layer, a single hidden layer and an output layer. As network input variables, forces in x and y directions are selected, while selected output network variables are displacements in x, y, and z directions, respectively.

Using custom script for Matlab, the ANN model is defined. The model's input layer consists of two neurons, the hidden one of ten neurons, while the output one has 3 neurons (Fig. 3). Using a trial and error process, the number of neurons in the hidden layer is determined, while the Levenberg–Marquardt back propagation algorithm is used for network training [10]. The algorithm uses the approximation

$$x_{k+1} = x_k \pm [J^T J + \mu I]^{-1} J^T e, \quad (2)$$

where J denotes Jacobian matrix that contains first derivatives of the network errors with respect to weights and biases, and e is a vector of network errors. As a performance measure during training, the mean squared error is used [11].

The dataset consists of 224 samples. Each set consists of 5 variables. These variables are applied forces in x and y directions and measured displacements (in ABAQUS) in x, y and z directions. To be able to import these variables into the ANN, the dataset has to be split into two matrices. One matrix consisting of applied forces in x and y directions is called “input”. The second one consisting of displacements in x, y, and z directions is called “target”. Based on “input” and “target” data, the ANN searches for a linear regression function and calculates the “output” data. The network performance is measured via “correlation coefficient R (Fig. 4)”. A value $R = 1$ implies that a linear equation describes

the relationship between “target” and “output” perfectly, with all data points lying on the line for which “output” increases as “target” increases.

When matrices are imported, training, validation and testing sets are randomly generated from the dataset. The network is trained using the training set (comprising 156 of 224 samples), and is adjusted according to its error. To measure network generalization the validation set (34 samples) is used. Also, this set is used to halt training when generalization stops improving. Finally, the independent test set (34 samples) with no influence on the training is used to measure network performance. This can be observed in Fig. 4, which shows the network performance for the training, validation and test set. Also, in Fig. 4 it can be observed that the total network performance is 0.99999, which is recognized as a fairly satisfying result.

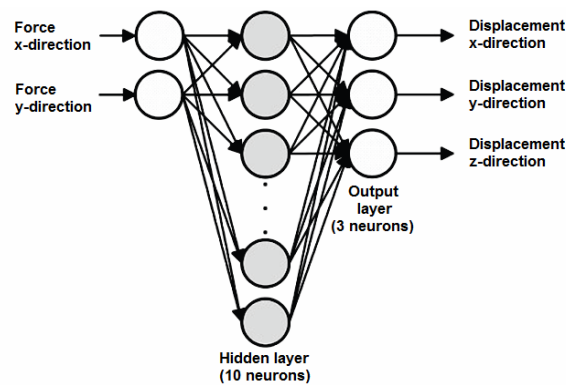

Fig. 3 Artificial neural network with 2 input variables, 1 hidden layer with 10 neurons, and 3 output variables

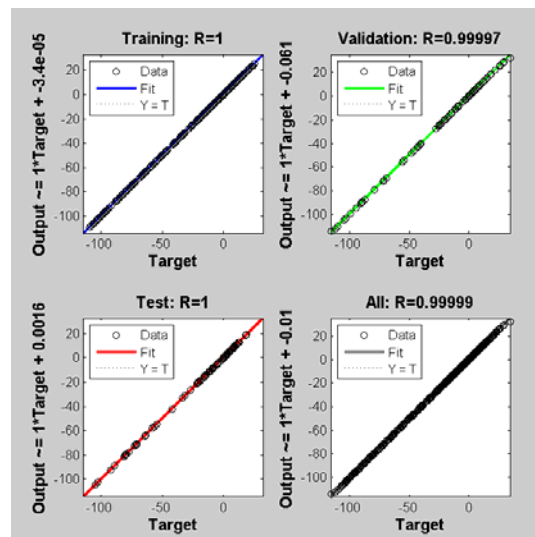

Fig. 4 Results of network performance for training, validation and test set

5. CONCLUSION

The paper takes into consideration the artificial neural network implementation in the analysis of a cylindrical arch shell structure, that is initially modeled in the ABAQUS software. The obtained results from the ABAQUS are used for training the artificial neural network, which is supposed to enable real-time simulation of the shell structure. This property is based on massive parallelism in neural networks which provides for an extremely efficient computational speed by means of suitable hardware and software implementation [12].

In this paper it is proposed that the need for a fast system that simulates real-time behavior of shell structures can be satisfied by using a neural network which is trained by using the raw experimental data obtained by the finite element method, representing the displacements of the structure to the various applied loads. In the second application phase, the trained neural network is capable of fast real-time approximation of shell displacements for the range of loads it is trained for.

The differences between the simulated values obtained from the FEM analysis and the predicted values from the ANN (value obtained by FEM / value obtained by ANN \times 100%) are within the range of 0.0001%, which shows good agreement which is obtained with a relatively modest network structure and, thus, with a modest training effort and moderate dataset.

Further research aims at providing an analysis of piezoelectric active structures. In the future, active/adaptive structures are expected to become more of a standard solution in many areas of application. This requires reliable and efficient modeling tools [1], which makes the prospective of combining the FEM modeling of piezoelectric active structures with artificial neural networks implementation potentially interesting. Also, an interesting future research direction could lead to the creation of a real time neural network based finite element analysis of shell structure that provides for the results in a much larger number of points and, possibly, in every node of the mesh. In the latter case, network parallelism could provide for an extremely efficient computation regardless of the possibly large FEM models.

Acknowledgements. *The paper is part of the research performed within the bilateral German-Serbian project "ICOSS - Intelligent Control of Smart Structures".*

REFERENCES

1. Marinković, D., Marinković, Z., 2012, *On FEM modeling of piezoelectric actuators and sensors for thin-walled structures*, Smart Structures and Systems, 9(5), pp. 411-426.
2. Noor, A.K. Belytschko, T., Simo, J.C., 1989, *Analytical and Computational Models of Shells*, The American Society of Mechanical Engineers, New York.
3. Bucelem, M.L., Bathe, K.J., 1997, *Finite Element Analysis of Shell Structures*, Archives of Computational Methods in Engineering, 4(1), pp. 3-61.
4. Javadi, A.A., Tan, T.P., Zhang, M., 2003, *Neural network for constitutive modeling in finite element analysis*, Computer assisted Mechanics and Engineering Sciences, 10, pp. 523-529.
5. Lefik, M., 2004, *Hybrid, finite element-artificial neural network model for composite materials*, Journal of Theoretical and Applied Mechanics, 42(3), pp. 539-563.
6. Sharma, K., Bhasin, V., Vaze, K.K., Ghosh, A.K., 2011, *Numerical simulation with finite element and artificial neural network of ball indentation for mechanical property estimation*, Sadhana, 36(2), pp. 181-192.

7. Marinkovic, D, Zehn, M. Marinkovic, Z., 2013, *The analysis of FEM results convergence in modelling piezoelectric active shell structures*, Transactions of FAMENA, 37(4), pp. 17-28.
8. Marinković, D., 2007, *A new finite composite shell element for piezoelectric active structures*, Ph.D. thesis, Otto-von-Guericke Universität Magdeburg, Fortschritt-Berichte VDI, Reihe 20: Rechnerunterstützte Verfahren, Nr. 406, VDI Verlag, Düsseldorf.
9. Čojbašić, Ž., Nikolić, V., Čirić, I., Čojbašić, Lj., 2011, *Computationally Intelligent Modelling and Control of Fluidized Bed Combustion Process*, Thermal Science, 15(2), pp. 321-338.
10. Moller, M.F., 1993, *A scaled conjugate gradient algorithm for fast supervised learning*, Neural Networks, 6(4), pp. 525–533.
11. Čojbašić, Ž., Brkić, D., 2013, *Very accurate explicit approximations for calculation of the Colebrook friction factor*, International Journal of Mechanical Sciences, 67, pp. 10–13.
12. Lukić, S., Čojbašić, Ž., Jović, N., Popović, M., Bjelaković, B., Dimitrijević, L., Bjelaković, Lj., 2012, *Artificial neural networks based prediction of cerebral palsy in infants with central coordination disturbance*, Early Human Development, 88(7), pp. 547–553.

ANALIZA LJUSKE U REALNOM VREMENU METODOM KONAČNIH ELEMENATA ZASNOVANOJ NA NEURONSKOJ MREŽI

U poslednjih nekoliko godina, metoda konačnih elemenata je široko korišćena kao moćno sredstvo u analizi inženjerskih problema. Prilikom simulacije deformabilnih objekata metodom konačnih elemenata, koristi se kompleksan sistem čvorova koji formiraju mrežu tačaka. FEM model uključuje svojstva materijala i same strukture koja definišu kako će struktura reagovati na određena opterećenja. Pouzdana simulacija treba da obezbedi lakši, brži i jeftiniji razvoj struktura. Simulacija deformabilnih objekata tipa ljuske u realnom vremenu korišćenjem metode konačnih elemenata je veliki izazov zbog potrebe za brzim sistemima, koji ne zahtevaju velike računarske resurse. U ovom radu smo prikazali efikasan metod zasnovan na neuronskim mrežama za simulaciju u realnom vremenu ponašanja tankozidne ljuske modelirane metodom konačnih elemenata u komercijalnom FE softveru. Korišćenjem metode konačnih elemenata, u režimu obučavanja neuro mreže sračunate su deformacije za primenjena opterećenja u određenom opsegu. U režimu aplikacije, korišćenjem obučene neuronske mreže dobijaju se potrebni rezultati za navedena opterećenja u realnom vremenu.

Ključne reči: metod konačnih elemenata, neuronska mreža, simulacija, tankozidna struktura, ljuska