



To Devise Of Fusion Network For Augment The Efficiency At Solar Photovoltaic System

PAPABATTINA GANDHI

M.Tech Student, Department Of EEE,
Priyadarshini Institute of Technology & Science,
Chintalapudi, Tenali, A.P, India.

U R SANKAR YALAVARTHY

Assistant Professor, Department Of EEE,
Priyadarshini Institute of Technology & Science,
Chintalapudi, Tenali, A.P, India.

Abstract: A manage rule for a standalone well-known individual electric powered phenomenon (PV)-the diesel-battery hybrid device is enforced at some point of this paper. The planned tool deals with the intermittent nature of the power generated via the PV array and it conjointly gives electricity splendid development. The PV array is included thru a dc-dc enhance converter and is controlled the use of the handiest factor pursuit rule to get the maximum power beneath varying in operation conditions. The battery strength garage tool (BESS) is protected inside the ICE generator set for the coordinated load manage and power waft within the device. The admittance-primarily based completely manage rule is hired for load equalization, harmonics elimination, and reactive strength reimbursement below 3-section four-wire linear and nonlinear hundreds. A 4-leg voltage-deliver converter with BESS conjointly offers unbiased current repayment. The standard common overall performance of the planned stand-by me hybrid device is studied under sincerely precise loading situations through a take a look at on an advanced epitome of the device.

Keywords: Admittance-Based Control Algorithm; Battery Energy Storage System (BESS); Diesel Generator (DG) Set; Solar Photovoltaic (PV) Array; Standalone System;

1. INTRODUCTION:

The help for the employment of renewable energy sources is increasing as heating is a chief environmental issue, and it gives any other for future energy provision. Among the out, their renewable electricity sources, big name electrical phenomenon (PV) electricity generation is gaining huge reputation, and it's used for several programs like household home equipment, far flung missions, statistics communications, telecommunication structures, hospitals, electrical craft, and solar cars [1]. The usage of the PV strength generation is for the cause that it's several benefits like it gives easy power, is movable in nature, and can use for several small-scale programs [2]. However, thinking about the huge fluctuations inside the output of PV power, it is imperative to integrate different strength sources kind of a diesel generator (DG) set, battery storage, gasoline cells, and many others. The overall performance analysis of standalone structures with PV- and DG-based resources is given in [3]. The layout and operation of standalone DG-SPV-battery electricity garage (BES) using a peak detection based totally basically control technique are proven in [4]. A personality triangle operates (CTF)-primarily based control method and its evaluation for four-twine standalone distribution gadget area unit incontestable. Partner improved segment-locked loop (EPLL)-primarily based control approach is shown in [6], whereby 3 EPLLs vicinity unit used for extraction of fundamental lively and reactive power factors of load currents. However, solely simulation studies vicinity unit bestowed. A

composite observer-based totally manage technique for the standalone PV-DG-based totally device is hired. However, the authors have provided experimental effects, but the control technique in superior and needs stanldardization of inner parameters. In assessment to the control method the projected gadget makes use of a conductance-based easy control approach. Moreover, a close experimental observe is hired to illustrate all of the alternatives of the machine. The projected machine includes a diesel-engine-driven static magnet synchronous generator (PMSG), PV array, and BES.

2. PREVIOUS STUDY:

Nowadays, the fast increase in the use of nonlinear masses along with computer structures, physics home gadget, scientific instrumentation, refrigerators, and lots of others. Has emphasized the concern for strength awesome in the electric powered distribution device. These hundreds inject harmonics and deform this and voltage waveforms inflicting bad power high-quality issues. The practicable provision for the mitigation of the potential high-quality issues is with an inclusion of custom strength devices whereas assembly the IEEE-519 every day. Three-section four-wire hundreds also are high-quality-identified to suffer from the hassle of unbiased current-day due to nonlinearity and unbalance present in the system. This could possibly turn out the notable deal of impartial cutting-edge-day that consists of triple harmonics. The unbiased present day may additionally motive overloading of the distribution system and reasons extra warmth losses, which can

be risky and poses a severe chance to the associated instrumentation. A four-leg VSC is used for independent contemporary-day reimbursement moreover to mitigate the modern harmonics with possibility rumoured advantages. Additionally, the flexible operation of the tool relies upon at the implementation of the numerous management techniques. Some of the control algorithms which might be applied for dominant area unit multi-loop method, sliding-mode control, and P controller based totally approach, FLC-based totally manage technique and elevated segment bolted technique. The authors want to fail to discuss the potential of superb and reactive strength reimbursement. The response of those controllers to the unbalance and dynamic conditions are sluggish. In this paper, the associate diploma admittance-primarily based control system is applied for the evaluation of reference strength part of source currents inside the PV-DG hybrid machine. The admittance of the load is calculable exploitation of the lively and reactive powers of the burden. The electric phenomenon (GL) and susceptance (BL) region unit extracted from the calculable energetic strength and reactive energy of the 3-phase four-cord masses, severally. It's a clean mathematical method supported curved Fryze cutting-edge-day control.

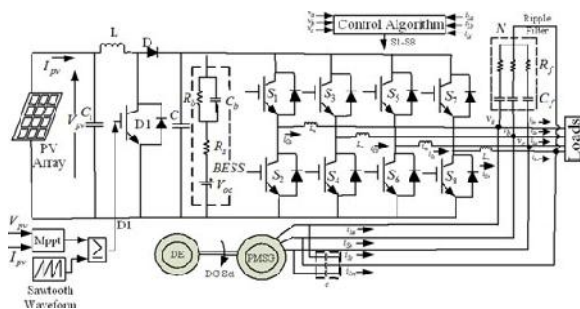

Fig.2.1.Proposed diagram.

3. SYSTEM DESIGN:

The standalone gadget consists of a PV array together with a lift converter, maximum wall plug pursuit (MPPT) controller, diesel-engine-driven PMSG, a four-leg VSC with BESS, and three-section 4-twine ac hundreds as proven in Fig. 1. The voltage at the PCC is repaired through way of coordinating the reactive electricity thru VSC control. Underneath variable situations of technology and loads, BESS gives to rate sooner or later within the daylight when the insulation is huge and additionally the weight is a smaller amount. The battery discharges to make amends for any deficits. The weight unit set operates on the equal time as preserving the tool frequency underneath variable era and hundreds. The terminal capacitance offers a relentless rated terminal voltage at no load. A four-leg VSC is interfaced on with its dc bus. The ripple filters out and interfacing inductors square diploma used to

eliminate the shift harmonics. The battery is hooked up with the resource of the dc hyperlink of the VSC. The battery is the companion diploma strength storage unit, its electricity is drawn in kilowatt-hour, and a capacitance is hired to model the battery unit as confirmed in Fig. 2.Eight-kWh functionality battery rack is hired for the energy garage. Therefore, thirty-six sections of twelve V and 7 Ah rectangular diplomas associated in collection. The parallel configuration of the metal element and Cb describes the charging/discharging preserve power and voltage. The rate of resistance steel element = ten k is massive, while Rs = zero.1 W is fantastically small for all practical abilities. The battery operates consistent with the burden versions. In situations, as soon as the weight call for has progressed, beneath the only's conditions, the ability maintain inside the battery is used, and consequently, the battery starts off evolved discharging in keeping with its discharge charge. Inside the case of reduced load call for, the battery prices from the accessible PV power as soon as the load name for is happy.

4. SIMULATION RESULTS:

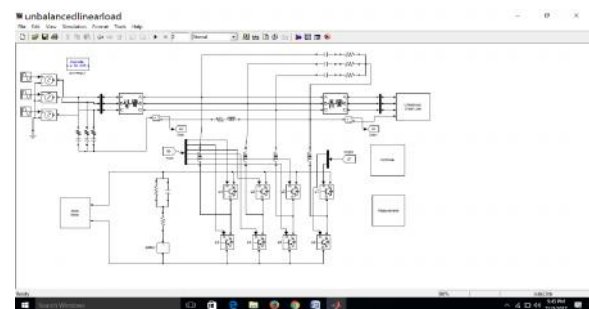

Fig.4.1.simulation circuit.

The response of a standalone machine is analyzed below the nonlinear load mistreatment sim-electricity system tool case in MATLAB/SIMULINK. The standard overall performance of the system is decided in some unspecified time in the future of line outage in one among the three stages at time $t = one$. Five to at least one. Fifty six s, as verified in Fig. Four. It is observed that for a subjected load unbalance in the device, the four-leg VSC has the capacity of harmonics elimination due to the fact the supply currents and moreover the deliver voltages are maintained steady and independent cutting-edge compensation is furnished whereas preserving a 0 supply neutral modern. The neutral modern-day-day repayment furnished by using the four-leg VSC is honestly illustrated with the versions within the load unbiased present day and VSC neutral present day waveforms. The system continues its PCC voltage at the required degree. Moreover, it need to be cited that even all through unbalanced loading, the deliver currents location unit balanced and curved thereby using ensuing in balanced loading at the

DG, that successively results in reduced protection and advanced efficiency of metric weight unit.



Fig.4.2.Output Currents waveforms.

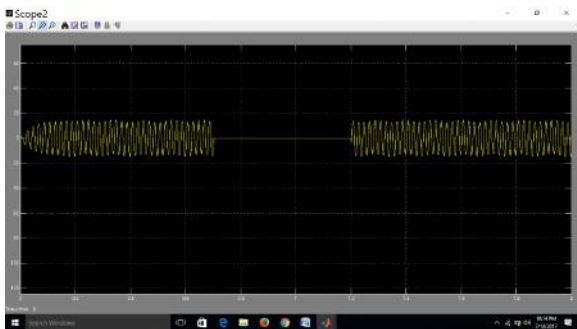

Fig.4.3.Output wave of current level A.

5. CONCLUSION:

The admittance-based totally control approach has been used for a PV-diesel-battery hybrid device for accomplish uninterrupted electricity supply and electricity wonderful improvement. The incremental-based MPPT method has brought maximum solar panel electricity under various situations of temperature and insulation radiation. The approach has been incontestable to put off harmonics, load equalization, and to deliver impartial contemporary-day compensation by using the usage of incorporating four-leg VSC within the tool. The PCC voltage and frequency are maintained continually. Satisfactory overall performance of the system has been determined through test effects acquired for steady-nation and dynamic situations under every linear/nonlinear mass.

REFERENCES:

- [1] N. A. Ninad and L. A. C. Lopes, "A BESS device for lowering gas intake and renovation fees of diesel hybrid mini-grids with excessive penetration of renewables," in Proc. IEEE ECCE Asia Downunder, Melbourne, Australia, 2013, pp. 409–415.
- [2] M. Datta, T. Senjyu, A. Yona, T. Funabashi, and C.-H. Kim, "A coordinated manage method for leveling PV output strength fluctuations of PV-diesel hybrid structures related to remoted strength utility," IEEE

Trans. Energy Convers., vol. 24, no. 1, pp. 153–162, Mar. 2009.

- [3] S. G. Malla and C. N. Bhende, "Enhanced operation of complete "photovoltaic-diesel generator-battery" device," J. Elect. Power Syst. Res., vol. 107, pp. 250–257, Feb. 2014.
- [4] B. Singh and S. Sharma, "An self sufficient wind strength conversion device with magnet synchronous generator," in Proc. IEEE Int. Conf. Energy, Autom. Signal, Bhubaneswar, India, 2011, pp. 1–6.
- [5] M. Datta, T. Senjyu, A. Yona, and T. Funabashi, "Photovoltaic output energy fluctuations smoothing with the useful resource of choosing most important functionality of battery for a -diesel hybrid tool," Elect. Power Compon. Syst., vol. 39, pp. 621–644, 2011.
- [6] S. C. Smith, P. K. Sen, and B. Kroposki, "Advancement of strength garage devices and packages in energy machine," in Proc. IEEE Power Energy Soc. Gen. Meeting, Convers. Del. Elect. Energy 21st Century, 2008, pp. 1–eight.
- [7] G. Wang, M. Ciobotaru, and V. G. Agelidis, "PV station mistreatment hybrid power garage system with superior efficiency," in Proc. Zero.33 IEEE Int. Symp. Power negatron. Distrib. Gener. Syst., 2012, pp. 808–813.
- [8] K. R. Padiyar, FACTS Controllers in Power Transmission and Distribution. New Delhi, India: New Age Int., 2008.
- [9] R. R. Sawant and M. C. Chandorkar, "A multifunctional four-leg grid connected compensator," IEEE Trans. Ind. Appl., vol. Forty 5, no. 1, pp. 249–259, Jan./Feb. 2009.
- [10] H. Mahmood, D. Michaelson, and J. Jiang, "Control method for a standalone PV/battery hybrid device," in Proc. 38th IEEE Annu. Conf. Ind. Electron. Soc., 2012, pp. 3412–3418.