



Propose And Performance Of Smart Home Organization System By Using IOT

B UMADEVI

M.Tech Student, Department Of ECE, Nishitha
College of Engineering and Technology,
Hyderabad, T.S, India.

K SREE VIDYA

Assistant Professor, Department Of ECE, Nishitha
College of Engineering and Technology,
Hyderabad, T.S, India.

Abstract: Home Automation agency is growing hastily; that is fuelled with the resource of providing helping structures for the elderly and the disabled, in particular people who live alone. Coupled with this, the world population is confirmed to be getting old. Home automation systems need to comply with the own family necessities and comfort of utilization. The GSM modem is used to ship the alert messages to the user if any of the sensors fees goes beyond the brink degree. All the sensor stages and the overall huge style of devices fed on had been sent to the predefined net web page with the aid of the use of using the Wi-Fi module. The Wi-Fi module changed into interfaced to the controller via the UART port. The emergency transfer supplied became to get the reputation of all of the sensors values inside the form of SMS.

Keywords: WIFI Module; GSM Modem; UART port; threshold Level;

I. INTRODUCTION

The current electricity catastrophe has required big electricity good deal in all regions. The power intake in home areas has extended as the domestic home device are set up. Energy saving and renewable energy sources are considered as strategies for solving domestic strength hassle. Both electricity consumption and era need to be concurrently taken into consideration to save the house electricity rate. Several researchers have proposed home strength control tool. Optimization of home energy consumption primarily based honestly totally on strength line communication (PLC) has been studied to provide smooth-to-get right of get entry to home energy consumption. This portray considers a device management module to deal with a networked home device; it does now not go through in mind the power intake. An inexperienced HEMS that video show gadgets, compares, and controls home domestic device has been proposed. It does now not keep in mind renewable energies. As sun and wind electricity device is deployed, electricity manage structures had been studied to enhance the smart home. These works go through in mind high-quality renewable energies, now not the strength intake. Digital input and output (DIO) strains thru which the house controller tool can integrate physical and conversion sensors and be prolonged to permit safety settings, power reporting, and scenario management. The network manipulate device now not extraordinary offers community and domestic manage services and 0.33-celebration offerings that permit communiqué with the cloud company platform however moreover integrates a huge display and control tool, surveillance system.

II. PRIVIOUS STUDY

Home electricity management tool (HEMS)-related gadgets are set up outside and inside houses (i.e., areas reachable to most of the people); as an instance, solar panels are hooked up on residential rooftops. Previous research has advised that hierarchical architectures composed of community gadgets can sell records and provider sharing among numerous households. However, these studies have lacked real environments in which to broaden such architectures, often deploying the structure on cloud structures. HEM tool comprises a HEM unit that gives tracking and control functionalities for a house owner, and load controllers that collect electrically powered intake statistics from determined on the home system and carry out close by managing primarily based on command indicators from the HEM machine. A gateway, at the side of a smart meter, can be used to provide an interface between a utility and the records base for the electric consumption is also maintained through a net.

III. METHODOLOGY

This has a look at first proposed a hierarchical, clever home service architecture, which employed well-known interface gadgets at the home quit to split the logic and user interfaces, and reaching a couple of in-domestic displays. Moreover, this look at implemented a community broker role to integrate smart home services together with handling environment deployment operations, lowering the guide labour required of network management employees, imparting digital records offerings, helping diverse offerings, and extending the network's integration with the surrounding environment. Therefore, a complete and the integrated clever home machine may be finished. In addition, integrating cloud-primarily based offerings with network services provided location-

based offerings. The LPC2148 microcontrollers are primarily based on a 16-bit/32-bit ARM7TDMI-SCPU with real-time emulation and embedded trace support that integrate the microcontroller with embedded excessive-pace flash reminiscence ranging from 32 kb to 512 kb. A128-bit wide memory interface and unique accelerator architecture enable 32-bit code execution on the maximum clock price. Serial communications interfaces ranging from a USB 2.Zero Full velocity device, multiple UARTs, SPI, SSP to I2C-bus and on-chip SRAM of 8 kb up to forty kb, make those gadgets very well suitable for communication gateways and protocol converters, gentle modems, voice reputation and occasional cease imaging, providing each large buffer size and excessive processing strength. An energy meter or strength meter is a device that measures the amount of electric energy consumed with the aid of a residence, commercial enterprise, or an electrically powered tool. Electricity meters are normally calibrated in billing devices, the most common one being the kilowatt hour. Periodic readings of electrical meters establish billing cycles and energy used at some point in a cycle.

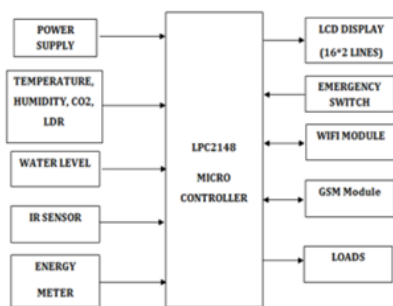

Fig.3.1. Block diagram.

IV. SIMULATION RESULTS

LM35 converts temperature price into electrical signals. LM35 series sensors are precision included-circuit temperature sensors whose output voltage is linearly proportional to the Celsius temperature. In this assignment, we are the use of different kinds of the sensor to a degree the diverse climate parameters within the filed/ domestic and additionally for the protection. To do that task, we are using the LPC 2148 Microcontroller, which has inbuilt ADC channels. In this undertaking, where the usage of the special sensors like, a temperature sensor (lm35) to measure the surrounding temperature, humidity sensor, CO2 sensor, light sensor, IR sensor, and the water stage sensor. The entire one's sensors will offer us the analog values however the controller will take best the virtual information. So, we have to join these kinds of sensor values to the ADC channel pins of the microcontroller. Then the ADC will convert this form of values to the corresponding digital values.

In this challenge, we are using the electricity meter to a degree the electricity fed on through the electric loads in the concern/ domestic. The water level sensor is used to measure the moisture stage of the plants and turn on the water pump every time needs. The IR sensor is used to feel the stranger entered the residence. All the one's sensor values will display on the LCD display screen continuously.



Fig.4.1. Hardware kit.

V. CONCLUSION

Hence a protected cloud-based definitely clever home management system with network hierarchy may be applied for getting access to sensor statistics from everywhere. This observes first proposed a hierarchical, smart home company shape, which hired famous interface devices at the residence stop to cut up the common sense and person interfaces and reaching multiple in-home presentations. Moreover, this check applied a community supplier function to mix clever home services inclusive of dealing with surroundings deployment operations, lowering the guide exertions required of a network manage employees, presenting digital information services, supporting numerous offerings, and developing the network's integration with the encircling surroundings.

VI. REFERENCES

- [1] M. Pipattanasomporn, M. Kuzlu, and S. Rahman, "An algorithm for intelligent domestic strength management and simulation for the call for response assessment," IEEE Trans. Smart Grid, every day for the book.
- [2] M. A. Piette, D. Watson, N. Motegi, S. Kiliccote, and E. Linkugel, "Automated name for reaction strategies and commissioning commercial building controls," in Proc. 14th Natl. Conf. Building Commissioning, San Francisco, CA, Apr. 2006.
- [3] D.Han and Lim, "Design and implementation of clever home energy management structures primarily based on ZigBee," IEEE Trans. Consum. Electron.,

- vol. Fifty-six, no. Three, pp. 1417–1425, 2010.
- [4] Y. S. Son, T. Pulkkinen, K. Y. Moon, and C.Kim, “Home energy control gadget based totally mostly on energy line communication,” *IEEE Trans.Consum. Electron.* Vol. Fifty-six, pp. 1380–1386, 2010.
- [5] J. Li, J. Y. Chung, J. Xiao, J. W. Hong, and.Boutaba,“Onthedesigand implementation of a domestic electricity control tool,” in*Proc.Sixth Int. Symp. Wireless Pervasive Comput. (ISWPC)*, Feb. 23–25, 2011, pp. 1–6.
- [6] J.Han, C.S.Choi, W.K.Park, and I.Lee,“Greenhome energy management tool via assessment of power usage a few of the same kinds of home domestic system,” in*Proc. 15h IEEE Int. Symp. Consum. Electron. (ISCE)*, 2011, pp. 1–4