

# Soil Erosion Estimation of Watershed Using GIS

## (A Case Study of Manjira Basin at Aurad Taluka)

**B. LEELA KRISHNA**

M. Tech in Dept. of Civil engineering (Water Resources Management) BKIT College of engineering Bhalki, Bidar District, Karnataka, India

**Prof.S. V. BIRADAR**

Professor and HOD of Dept. of Civil engineering (Water Resources Management) at BKIT College of engineering Bhalki, Bidar District, Karnataka, India

**Abstract:** To have any development activity especially for soil and water conservation measures, watershed management plays a vital role in conserving natural resources. Soil loss is a very serious problem which effects environment as it threatens agriculture and also surroundings. As the productivity of the land is caused by the soil loss and in turn down areas are adversely effected, soil conservation is a primary step for having any development activities. In reality, it is not possible to conserve all areas under threat of erosion because of the financial constraints. In practice, prioritization of watersheds is derived and vulnerable areas are prioritized and then taken for conservative methods and taking up the entire watershed would be financially not feasible. Many aspects are to be considered while prioritizing the watershed to be conserved like threats to lives, political suitability, social constraints etc, for the scope of this project the prioritization is not taken up as the study area is the catchment to small water body and the area considered is also small.

Soil loss is Estimated using GIS technique which is the present most powerful software to easily and quickly ascertain the required for large areas. Universal soil loss equation is the most common method of evaluating the loss although many modifications were made to this equation but all are based on the factors considered in USLE only like rainfall erosivity, soil erodibility, slope length, slope class, land cover and land management practices are taken as directly proportional to the rate of annual soil erosion.

In the present study, the watershed in Bidar district of Karnataka has been taken. The average annual erosion for the study area is estimated by USLE using GIS technique. The average soil loss from the watershed is estimated to be 892 tones/Ha/Year.

### I. INTRODUCTION

The importance of catchments studies lie in the facts like formation, development prolonged existence of a civilization. And it is strictly associated with long and short term difference in the behavior of a river water shed. productivity and sustainability of a location is determined by scenarios resulting from its interaction with climate especially rainfall. A watershed is characterized as the region from which overflow coming about because of precipitation streams past a solitary outlet. A river basin consists of a number of watersheds and sub watersheds associated with tributaries of Main River. In integrated approach of river basin, the stream bowl is partitioned into number of watersheds and sub watersheds and characteristics of each sub watershed are studied separately. Identification and measurements of these characteristics from time to time are of great importance in the contest of watershed studies and management programs. Watershed modeling is of quantifying the runoff and sediment yield of a watershed, expected from rainfall event or for supporting a watershed such as land, water bodies, forest cover, agricultural zones and control other physical activities within the watershed so as to achieve maximum productivity with minimum impact of environment.

### II. STUDY AREA

The watershed considered in the present study is situated in the Aurad region of Bidar district in Karnataka. Watershed selected area is 440.865 sq.km. The water shed is geographically located between North latitudes 18°17'28.6735" and East longitude 77°21'04.773". The watershed selected falls under the SOI topo sheet no 56F7.



Fig 3.1 Study Area

#### Manjira Basin:

Manjira is a tributary of the stream Godavari. It goes through the conditions of Maharashtra, Karnataka and Telangana. It starts in the Balaghat

scope of slopes close Ahmednagar district at an elevation of 823 meters (2,700)ft and streams into Godavari waterway. It has an aggregate catchment range of 30,844 Sq.km (3,084,400ha).

### III. MATERIAL AND METHODOLOGY

#### Methodology of USLE

The methodology involves in estimation of erosion or soil loss has been described below through the flow chart.

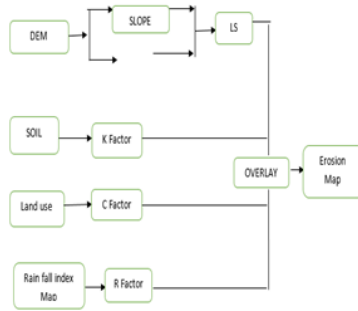

Fig 3.1 Methodology/flow chart

#### Parameters of the USLE Model

USLE gauge soil disintegration as far as tones/hectare/year and don't precisely speak to the measure of soil that leaves a field, enters a waterway or generally add to offsite disintegration harms. Nor do disintegration rates evaluated by the USLE fundamentally compare to the seriousness of the on location harms because of land efficiency, since such variables as soil profundity and sub soil quality are likewise critical determinants of a soil weakness to disintegration.

Or maybe the ULSE gauges the long haul normal measure of soil dislodged by the strengths of precipitation and water spillover along a predetermined slant. The form of the equation is

$$A = R * K * LS * C * P$$

Where A is the processed soil of per unit zone over a predefined time. It is normally communicated as tons/ha/year. A speaks to the potential long haul normal yearly soil misfortune in tons per section of land every year. This is the sum, which is contrasted with the "middle of the road soil misfortune" limits. R is the precipitation and overflow figure by geographic area .K is soil erodibility calculate. S steepness of field incline. L is length of slant. C is soil cover and administration soil calculate. P supporting preservation hone calculate.

#### Rainfall factor (R)

The rainfall characteristic best for estimating single storm soil erosion was the product of the total kinetic energy of the storm rainfalls and the max rainfall intensity over a continuous 30 minute period during the rainstorm. This was known as EI

or the R factor. The factor was better than rainfall amount, rainfall energy, maximum 15 or 30 minutes intensity and a multiple liner regression combining the above variables. For a particular soil on a plot with a slope of 9% and 72.6 feet, the slope of the relationship between soil loss and the rainfall factor, as determined by linear regression, was defined as the soil erodibility value K factor for the soil loss. Periods included seasonal and annual periods. For estimating R factor, the 330 minutes maximum rainfall is calculated as follows:

$$I_{30} = I_{24} (t/24)^{(2/3)}$$

But this method for estimating the R factor has limitations that it is developed under American conditions and is not suitable for the tropical and sub-tropical zones. The R factor is calculated relative to country and comparing station where calculation is to be made. For the Indian conditions the R factor is calculated as follows

$$R = -8.12 + 0.562 * \text{Annual Rainfall}$$

#### Soil Erodibility Factor (K)

K consider mirrors the inborn powerlessness of a dirt to dissolve, in the event that it is an infertile of product or buildup and presented to precipitation and spillover. The estimations of K are capacity of surface (the rates of sand, sediment and dirt measured particles), natural matter substance, physical structure and penetrability to water. K variable is the normal soil misfortune in tones/sections of land per unit range for a specific soil of unit plot 72.6 feet long with a 9% incline, kept up in a nonstop frequently worked decrepit condition with here and there slope culturing. K is a measure of the defenselessness of soil particles to partition and transport by precipitation and flood. K factor for various soils is given in table.1

Table.1 k factor data.(organic matter content)

Textural class	Average	Less than 2%	More than 2%
Clay	0.22	0.24	0.21
Clay loam	0.3	0.33	0.28
Fine sand	0.08	0.09	0.06
Fine sandy loam	0.18	0.22	0.17
Loamy fine sand	0.11	0.15	0.09
Sand	0.02	0.03	0.01
Sandy loam (chalka soils)	0.13	0.41	0.37
Silt loam	0.38	0.41	0.37
Very fine sandy loam	0.35	0.41	0.33

#### Slope length Steepness Factor (LS)

L and S consider speak to the impact of incline length and steepness individually. The erosive drive of spillover increments as incline steepness and length increments and the estimation of these components increment in like manner. The components L and S are joined together into a LS variables. LS are the incline length angle figure. The LS figure speaks to a proportion of soil misfortune under offered condition to that site with the "standard" incline steepness of 9% and slant length of 72.6 feet. The more extreme and longer the slant, the high in danger of disintegration. In this study, LS factor has been calculated as follows

$$LS = (\text{flow Accumulation} * \text{cell size}/22.13)^{0.4} * (\sin \text{slope} / 0.0896)^{1.3}$$

Where stream aggregation is the quantity of cells adding to stream into a given cell size is the measure of the cells being utilized as a part of the framework based portrayal of the heap scape Eq (3.4) depends on the proposal by Moore and Burch (1986) that there was a physical premise to the USLE, L and S figure mix. The result of four elements, RKLS, yields a gauge of the yearly normal sheet and rill disintegration (in tons) expected if a region of land were worked consistently all over any predominant slant and kept infertile vegetation. The conditions relating to a C estimation of 1 and a P estimation of 1. The incentive for the RKLS item along these lines speaks to a dirt's intrinsic potential for sheet and rill disintegration. Any disintegration control hones lessen soil misfortune on a specific field by bringing down either or both of the C or P esteems underneath.

#### Cover Management Factor (c)

It is likewise called as vegetative cover and administration consider. The estimation of C variable are increased by the result of RKLS to speak to the decrease from intrinsic erodibility achieved by editing arrangements, culturing practices and plant deposits on the dirt surface. C calculate values speak to the proportion of soil misfortune from land edited under indicated conditions to the comparing misfortune from clean worked nonstop decrepit. The cover management factors for various land uses are shown in Table .2

**Table.2 Cover Management factor values**

Land use	C-Factor
Agricultural lands	0.377
Open scrub	0.014
Fallow land	1
Water body	0

#### Conservation practice Factor (P)

The component P mirrors the disintegration control impacts of such supporting preservation hones as shaping, strip editing and terracing. These practices separate the length of down slant sections gone by overflow water into shorter fragments, accordingly restricting the volume and speed of moving water. Subsequently less soil is uprooted and transported. The P variable is the proportion of soil misfortune with a particular bolster practice to the comparing misfortune with here and there slant development.

**Table.3 Conservation practice Factor**

Support practices	P Factor
Up & down slopes	1.0
Cross slope	0.75
Contour framing	0.50
Strip cropping, cross slope	0.37

#### Estimation of Parameters of USLE Equation

The procedure to estimate the USLE parameters are below

##### Rainfall factor (R)

The rainfall factor is calculated using the equation 3.3 the rainfall data of the region is collected and annual rainfall is estimated. Annual rainfall value is applied to the equation 3.3 to get the R factor.

##### Soil erodibility factor (K)

Soil guide is arranged and digitized. In view of the dirt sort and expecting a normal natural substance in the dirt the K element are resolved from the table 3.1 and are added as credits to the dirt guide. A guide speaking to the K variables of the range is then produced.

##### Slope Length Steepness Factor (LS)

Watershed is an area from which water drain in to a single unit. So the slope of a watershed under study should be estimated in order to delineate the characteristics of the watershed. To estimate the flow accumulation and slope in the area we should generate a flow accumulation map and a slope map. To generate these tow maps we need to prepare the digital elevation model (DEM) of the area. To prepare the DEM, following layers have to be prepared: watershed boundary layer, drainage layer, contour layer and water bodies' layer. Following is the procedure to develop grid based DEM.

The DEM Map is obtained from the NASA based, Consortium for Spatial Information (CGIAR-CSI) is spatial science group that encourages CGIAR's universal agrarian advancement inquire about utilizing spatial investigation, GIS, and remote detecting. For this study the DEM of 90m

resolution DEM Map is downloaded and utilized for the study.

**Conservation Practice Factor (P)**

The P factor is based on the support practices adopted. For this study it is assumed that there is no support practice in the study area. So the P factor is one.

**IV. RESULT and DISCUSSION**

**Soil Loss Estimation:**

Wischmeier and smith (1978) first used the universal soil loss equation (USLE) to predict the annual average soil loss from the watershed under study. The parameters of the USLE model are estimated and converted to digital raster layer in GIS to estimate the soil loss. USLE compute soil loss of six major factors whose values are expressed numerically in the following sections.

**Rainfall Erosivity Factors(R)**

There is a direct relation between soil loss and rain fall by the detachment power of rain drop falls on soil surface and the transport of the detached soil particles by runoff water down the slope. It is a statistical value calculated using equation.

Table 5.1 gives the R factor calculated for different years. The average R factor for the watershed based on 16 year data is computed as 532.

*Table 4. R factor*

Year	1990-91	1991-92	1992-93	1993-94	1994-95	1995-96	1996-97	1997-98
R value	518.2	502.5	426.3	589.6	412.3	550.3	426.3	562.2

Year	1998-99	1999-00	2000-01	2001-02	2002-03	2003-04	2004-05	2005-06
R value	526.3	456.3	423.5	395.6	316.4	484.9	514.4	526.3

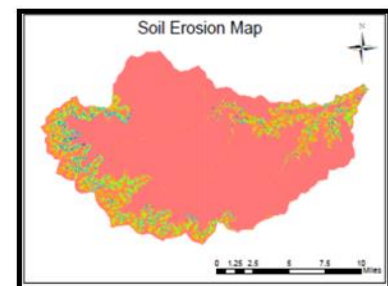
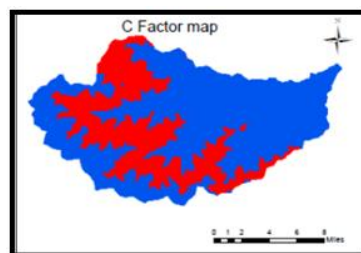
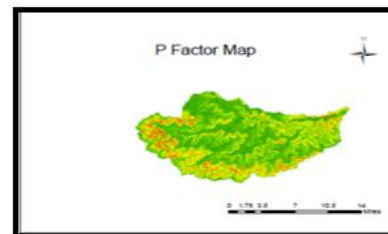
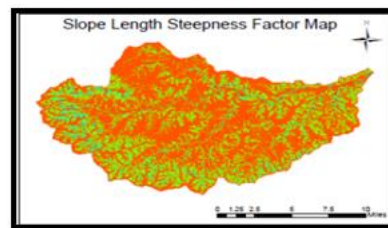
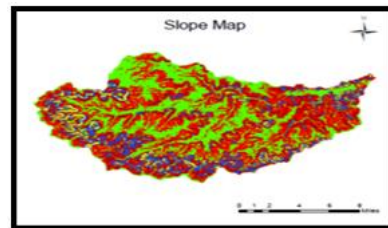
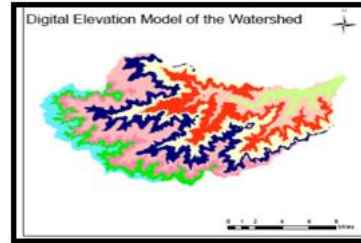
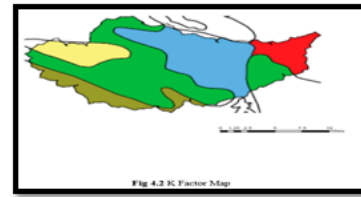
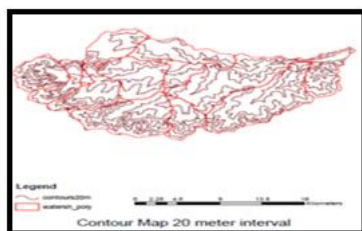



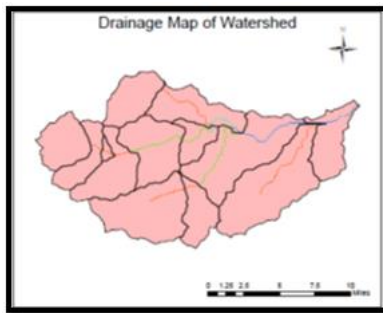
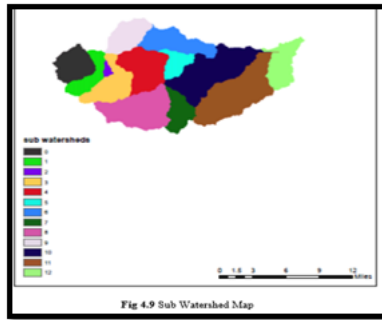

### V. CONCLUSION

1. The Average Soil Loss in the whole watershed is found to be 892 tons/ha/year.
2. The average R factor for the watershed based on 16 year data is computed as 532 mm.
3. GIS is very useful tool compared to other methods because it can divide the land surface into many cells, which permits analysis to be performed on both large regions as well as small areas.
4. The USLE model is a statistically based soil erosion model that is easy to parameterize and thus requires less data and time to run.
5. To analyze soil loss the six factors are estimated for soil erosion in that selected area of watershed.
6. The soil erosion map, derived from the application of an erosion Model like USLE permits to evaluate the erosion level in the subjected to soil degradation phenomenon.
7. Dividing watershed into different erosion zones helps in identification of the more susceptible areas to erosion process and to identify which mitigation measures would be necessary in order to reduce the problems connected to soil loss.

### VI. REFERENCES

[1]. Rong, “Application of remote sensing methods to hydrology and water resources” Hydrology sciences-journal-des sciences Hydrologiques,39,4 August 1994

[2]. Barrett, E. C. (1970) The Estimation of monthly rainfall satellite data. Mon. weath. Rev. 98,322

[3]. Chow, V.Y (1964) Hand book of hydrology, MC Graw Hill Book Company, New Delhi.

[4]. Krishna P.Pradhan, “Application of remote sensing and GIS in soil erosion hazard mapping and land suitability analysis in phewa watershed-A case study”.

[5]. The STRM (shuttle Radar topography mission) DEM model available from CSI-CGIAR web site.

[6]. Rainfall data is extracted from IMD (Indian meteorological department). Soil data is obtained from world soil map from FAO web site.

[7]. Krishna Pahari, Shunji Murai,“ Remote sensing and GIS for sustainable Watershed a studt from Nepal” paper presented at the 4<sup>th</sup> international symposium on High Mountain Remote sensing Cartography, Karland, August,1996.

[8]. Lillesand, T.M, and R.W Kiefer (1987), Remote sensing and image interpretation, john wesely & sons, New York.

[9]. Manoj k.jain, “estimation of soil erosion and sediment yield using GIS” Hydrology sciences -journal-des sciences Hydrologiques, 45(5) October 2000

[10]. Nageshwar R.Bhaskar (Member, ASCE) “Hydrologic parameter estimation using Geographic information system”. Water Resour. Res., 15(6), 1421-1434

[11]. Manu Omakurth (1989),”soil erosion mapping using remote sensing and GIS techiques.

[12]. Land and water Management Engineering by V.V.N Murty Madan K.Jha.

[13]. Remote Sensing and image interpretation by Lillesand Kiefer Chipman Sixth Edition.

[14]. Watershed Management – Guidelines for Indian Conditions by E.M. Tideman.