

FACTA UNIVERSITATIS

Series: **Electronics and Energetics** Vol. 28, N° 4, December 2015, pp. 611 - 623

DOI: 10.2298/FUEE1504611R

## ANALYSIS OF HALF-BAND APPROXIMATELY LINEAR PHASE IIR FILTER REALIZATION STRUCTURE IN MATLAB \*

Aleksandar D. Radonjić<sup>1</sup>, Jelena D. Čertić<sup>2</sup>

<sup>1</sup>Crnogorski telekom A.D., Montenegro

<sup>2</sup>School of Electrical Engineering, University of Belgrade, Belgrade, Serbia

**Abstract.** *In this paper a detailed analysis of an atypical filter structure in MATLAB Filter Design and Analysis (FDA) Tool is presented. As an example of atypical filter structure, the IIR half-band filter with approximately linear phase realized as a parallel connection of two all-pass branches was examined. We compare two types of those filters obtained by two different design algorithms. FDA tool was used for the experiment because different effects of the fixed point implementation can be simulated easily. One of the goals of this paper was to compare results obtained by two different design algorithms. In addition, different realizations of the filter structure based on the parallel connection of two all-pass branches were examined.*

**Key words:** *Approximately linear phase IIR filters, FDA Tool, Half-band IIR filters*

### 1. INTRODUCTION

The Digital filter design process consists of several steps. After the design itself, a very important step is the analysis of different aspects of filter implementation. If the filter is to be implemented in a fixed-point arithmetic, the quantization effects should be carefully examined [1]. This can be done by theoretical investigation, for example, by sensitivity analysis [2] and detailed round-off noise study. It is not always possible to calculate closed-form expressions for all transfer functions that are needed for the exact derivation of the sensitivity functions. For the digital filters, it is common practice to use numerical simulation of the quantization effects [3]. For that purpose, simulation model of specific target platform can be developed, or alternatively commercially available tools can be used. The first solution is time consuming and requires good knowledge of the fixed-point arithmetic and all the parameters of the target platform. For example, if the target platform is a DSP processor, it is not enough to take care of the word-length of the processor. Usually, it is necessary to fully understand the structure of the integrated multiplier. In the second approach, when a commercially available tool is used, analysis

---

Received December 3, 2014; received in revised form June 15, 2015

**Corresponding author:** Jelena D. Čertić

School of Electrical Engineering, University of Belgrade, Bulevar kralja Aleksandra 73, 11020 Belgrade, Serbia (e-mail: certic@etf.bg.ac.rs)

\* An earlier version of this manuscript received the Best Section Paper Award (Electric circuits and systems and signal processing section) at the 58th ETRAN Conference, Vrnjačka Banja, 2-5 June, 2014. [5].

time can be decreased. Analysis tools contain sets of typical values for relevant parameters of the proposed design. Drawback of this method is that commercially available analysis tools do not have the procedures for all possible cases. It means that in the case of a typical filter design, an analysis tool probably would be of no help. In this paper we analyze IIR half-band approximately linear phase filter by means of the commercial analysis tool. We use MATLAB Filter Design and Analysis (FDA) Tool [4] because it simulates quantization effects in a way that is suitable for the fixed-point implementation. We compare results obtained for filters designed by two different algorithms. Filter is realized as a parallel connection of two all-pass branches [1, 2]. Although parallel connection of two all-pass branches is a common choice for implementation of the low-pass/high-pass odd-order IIR filters [1, 2], it is not fully supported in MATLAB Filter Design and Analysis Tool [4, 5]. We define a procedure that can be used for the analysis by MATLAB FDA Tool of a specific filter structure, IIR half-band filter with approximately linear phase.

This paper is organized as follows: in section 2 performances of MATLAB FDA Tool relevant for the fixed-point implementation are presented; in section 3 the IIR half-band approximately linear phase filters are discussed; in section 4 possible realization structures are defined, in section 5 results of the analysis are presented, and section 6 concludes the paper.

## 2. MATLAB FDA TOOL

In recent years, the new versions of MATLAB are available twice a year [6]. Typically, each new version has some new features regarding filter design and analysis. Filter Design and Analysis (FDA) Tool is part of the signal processing toolbox [4]. By using the FDA Tool, different filter structures can be designed and analyzed in a rapid way, because the FDA Tool itself contains algorithms for the design of different filter types and the large set of analysis procedures. However, sometimes it seems that new features are not introduced in this tool fast enough.

For the scope of our project, part of the FDA tool related to the simulation of the quantization effects is important. It should be noted that the simulation of the quantization requires an additional (fixed point) toolbox.

Filter arithmetic:	Fixed-point
Rounding mode:	Nearest (convergent)
Product mode:	Full precision
Accum. mode:	Keep MSB
Product word length:	32
Accum. word length:	40
Num. fraction length:	28
Num. fraction length:	28
Den. fraction length:	29
Den. fraction length:	29
<input checked="" type="checkbox"/> Cast signals before accum.	

**Fig. 1** FDA Tool - setting simulation parameters of the multiplier

For the supported filter types, FDA simulation of the quantization is a powerful tool that allows the user to verify robustness of the filter structure to different effects of the quantization process. The user can define word-length parameter for the input signal and output signal and filter coefficients. In addition, the number of bits associated to the fractional part of the data (input signal, output signal and filter coefficients) can be set. Multiplier/accumulator structure can be simulated by defining values for relevant parameters, Fig. 1. The user can enter data through the GUI or choose a set of predefined values.

The predefined values usually correspond to “best possible” scenario that is not always possible to obtain in “real world” situations, but can be useful for the users inexperience in fixed-point applications.

### 3. HALF-BAND APPROXIMATELY LINEAR PHASE IIR FILTERS

An odd order IIR filter (or filter pair) can be implemented as a parallel connection of two all-pass branches  $A_0(z)$  and  $A_1(z)$ , Fig. 2. The transfer functions of the low-pass filter,  $H_{LP}(z)$ , and of the high-pass filter  $H_{HP}(z)$  are obtained as:

$$H_{LP}(z) = \frac{A_0(z) + A_1(z)}{2}, \quad (1a)$$

$$H_{HP}(z) = \frac{A_0(z) - A_1(z)}{2}. \quad (1b)$$

Usually, all-pass branches are implemented as the cascaded connections of the one first order section, and second order sections:

$$A_0(z) = \prod_{l=2,4,\dots}^{(N+1)/2} \frac{a_{l2} + a_{l1}z^{-1} + z^{-2}}{1 + a_{l1}z^{-1} + a_{l2}z^{-2}}, \quad (2a)$$

$$A_1(z) = \frac{a_{11} + z^{-1}}{1 + a_{11}z^{-1}} \prod_{l=3,5,\dots}^{(N+1)/2} \frac{a_{l2} + a_{l1}z^{-1} + z^{-2}}{1 + a_{l1}z^{-1} + a_{l2}z^{-2}}, \quad (2b)$$

where  $N$  is the filter order, an odd number, and the constants  $a_{li}$ ,  $l=1, 2, 3, \dots, (N+1)/2$ ,  $i=1, 2$  are first and second order sections coefficients [2]. It should be noted that for the overall filter  $H_{LP}(z)$  of order  $N$  (an odd number), the order of the all-pass branch  $A_0(z)$  is an even number  $N_0$  and the order of the all-pass branch  $A_1(z)$  is an odd number  $N_1$ . Frequency response of the parallel connection of the low-pass filter is:

$$H_{LP}(e^{j\omega}) = \frac{e^{j\varphi_0(\omega)} + e^{j\varphi_1(\omega)}}{2} = e^{\frac{j\varphi_0(\omega)}{2}} e^{\frac{j\varphi_1(\omega)}{2}} \frac{e^{\frac{j\varphi_0(\omega)}{2}} e^{-\frac{j\varphi_1(\omega)}{2}} + e^{-\frac{j\varphi_0(\omega)}{2}} e^{\frac{j\varphi_1(\omega)}{2}}}{2} = \cos\left(\frac{\varphi_0(\omega) - \varphi_1(\omega)}{2}\right) e^{j\frac{\varphi_0(\omega) + \varphi_1(\omega)}{2}}. \quad (3)$$

where  $\varphi_0(\omega)$  and  $\varphi_1(\omega)$  are phase responses of the functions  $A_0(z)$  and  $A_1(z)$ .

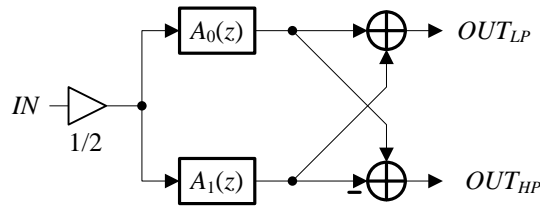

**Fig. 2** IIR odd order filter realization as a parallel connection of two all-pass filters

From (3) it can be concluded that the overall magnitude response depends on the difference of the phase responses of the all-pass functions. The overall phase response of the filter  $H_{LP}(z)$  is a mean-value of the phase responses of the all-pass branches.

Comparing to the classical implementation structures of the IIR filters that are based on the cascaded or parallel connections of the first and second order sections, realization based on the parallel connection of the two all-pass branches has reduced sensitivity in the pass-band [2, 7]. For that reason, it is usually a preferable choice for the implementation structure in the case of fixed-point implementation [2]. On the other hand, filter structure based on the parallel connection of the two all-pass branches suffers from the high stop-band sensitivity [2, 7]. In the case when high stop-band attenuation is required, quantization effects can degrade the filter frequency response [2].

In the special case of the half-band filter with approximately linear phase, the all-pass branch  $A_1(z)$  is a pure delay  $z^{-N_1}$ , and the all-pass branch  $A_0(z)$  is an all-pass function with approximately linear phase. In that special case, the filter order of the all-pass branch  $A_0(z)$  is an even number  $N_0 = N_1 + 1$ . In addition, every second coefficient of the function  $A_0(z)$  is zero-valued:

$$A_0(z) = \frac{a_{N_0} + \dots + a_{2k}z^{-N_0+2k} + \dots + a_2z^{-N_0+2} + z^{-N_0}}{1 + a_2z^{-2} + a_4z^{-4} + \dots + a_{2k}z^{-2k} + \dots + a_{N_0}z^{-N_0}}. \quad (4)$$

Half-band filter with approximately linear phase is a special case of the IIR filter realization based on the parallel connection of the two all-pass branches. For that reason, the sensitivity of the filter is low in the pass-band and high in the stop band.

Design of the half-band IIR filter with approximately linear phase is performed by design of the all-pass branch  $A_0(z)$ , approximately linear phase all-pass function. In this paper, we use filter transfer functions obtained by two different algorithms, one based on the optimization method [8] and the other based on the direct positioning in the  $z$  domain of the stop-band zeros of the low-pass filter transfer function [9, 10].

The first solution, originally presented in [8], design all-pass approximately linear phase transfer function  $A_0(z)$  by optimization procedure. As an outcome, overall magnitude response of the half-band IIR filter  $H_{LP}(z)$  is equiripple. Results obtained by design [8] for the filter of order  $N = 23$  ( $N_0 = 12$ ,  $N_1 = 11$ ) are presented. The filter gain is shown in Fig. 3 and the group delay of the filter in Fig. 4. It should be noted that the pass-band group delay is approximately  $N_1$  samples.

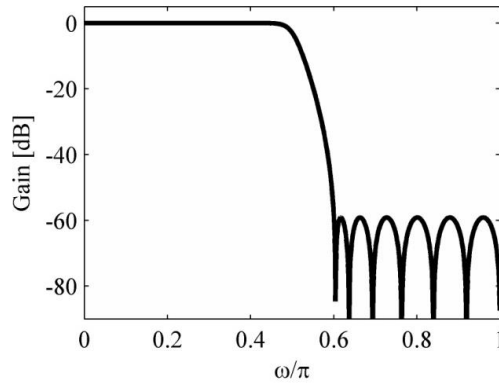

**Fig. 3** Gain response of the filter designed by optimization algorithm [8]

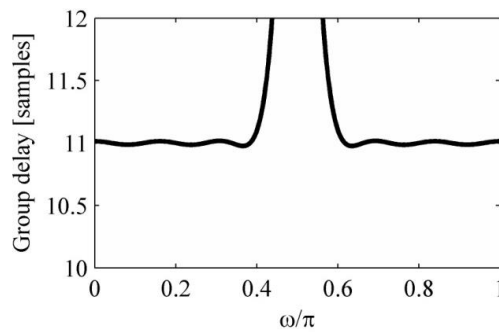

**Fig. 4** Group delay of the filter designed by optimization algorithm [8]

The second approach, presented in [9] and [10], actually controls the positions of stop-band zeros of the overall half-band filter. In the case of the low-pass filter design, sometimes it is important to provide additional signal attenuation for certain frequencies on the stop-band. It can be achieved by the exact control of stop-band zeros positions. By placing a stop-band zeros exactly on the unit circle, large attenuation of the corresponding frequency range can be achieved. In the design approach presented in [9, 10] it is possible to control the stop-band frequencies for which an infinitely large attenuation is needed. It was shown in [9, 10] that the stop-band zeros of the low-pass half-band IIR filter are roots of the polynomial function

$$P_L(w) = -1 + a_2U_2(w) + a_4U_6(w) + \dots + a_{2k}U_{4k-2}(w) + a_{\frac{N+1}{2}}U_{(N+1)-2}(w) \quad (5)$$

where are:  $N$  is overall filter order,  $a_{2k}$  are coefficients of the non-trivial all-pass branch (order of the non-trivial all-pass branch is  $N_0 = (N + 1)/2$ ),  $w = \sin(\omega)$  and  $U_{4k-2}(w)$  is the Chebyshev polynomial of the second kind. There are  $(N + 1)/4$  low-pass half-band IIR filter stop-band zeros lying on the unit circle. If the stop-band zeros are defined according to the filter specifications and all-pass filter coefficients are unknown, then (5) can be transformed into the system of linear equations (one equation for each zero). Values of  $(N + 1)/4$  all-pass branch coefficients are calculated by solving system of linear equations.

Results obtained by the second approach of the design are presented for the same filter order and overall characteristics similar to characteristics obtained by the first approach case. The filter gain is shown in Fig. 5 and the group delay of the filter in Fig. 6.

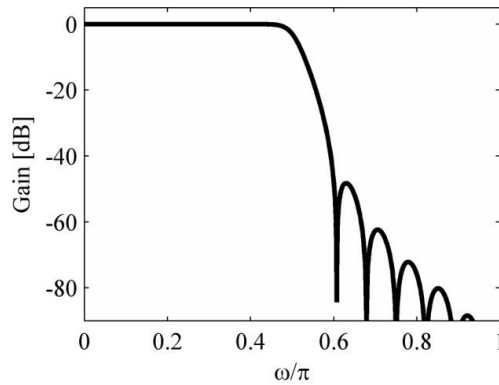

**Fig. 5** Gain response of the filter designed by zero positioning algorithm [9, 10]

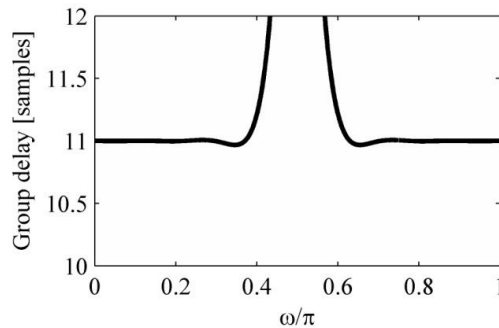

**Fig. 6** Group delay of the filter designed by zero positioning algorithm [9, 10]

It should be noted that both filters share the same realization structure, Fig. 1. Therefore, for the filter analysis of both structures it is essential to analyze nontrivial all-pass branch of the filter  $A_0(z)$ .

#### 4. IMPLEMENTATION OF THE HALF-BAND APPROXIMATELY LINEAR PHASE IIR FILTERS

The goal was to develop a procedure for the detailed analysis of the filter structure presented in Fig. 1 in the case of the fixed-point realization. The objective was to compare half-band IIR filters with approximately linear phase obtained by two different algorithms and to select for each of the two filter types, a filter realization that is most suitable for the case of fixed point implementation platform. Three different implementations of the all-pass branch were analyzed, direct realization, cascaded connection of the second order sections and cascaded connection of the fourth sections.

Since the filter  $H_{LP}(z)$  is a half-band filter, poles of the transfer function  $A_0(z)$  are symmetric about the imaginary axis. Poles and zeros of  $A_0(z)$  occur in conjugate reciprocal pairs. All-pass filter  $A_0(z)$  is of order  $N_0 = 4l + 2$  or  $N_0 = 4l + 4$ . In the  $4l + 2$  case, all-pass filter  $A_0(z)$  has two poles on the imaginary axis and  $l$  quadruplets of poles, Fig. 7a. In the  $4l + 4$  case, there is additional pair of poles placed on the real axis, Fig 7b. All-pass branch  $A_0(z)$  can be implemented as a direct structure of order  $N_0$ , or as a cascaded connection of lower order sections. However, because  $H_{LP}(z)$  is the half-band filter, symmetric poles and corresponding zeros can be grouped into the fourth order sections. As a result, transfer function  $A_0(z)$  can be implemented as a cascaded connection of one (for  $N_0 = 4l + 2$ ) or two (for  $N_0 = 4l + 4$ ) second order section(s) and  $l$  fourth order sections.

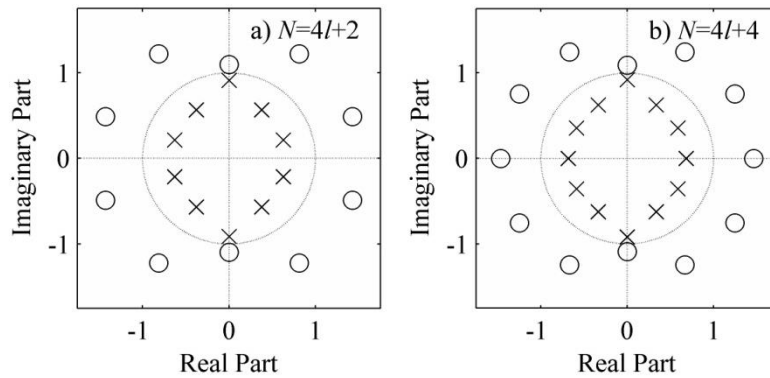

**Fig. 7** Poles (x) and zeros (o) of the all-pass transfer function  $A_0(z)$ , a) filter order is  $N_0 = 4l + 2$ , b) filter order is  $N_0 = 4l + 4$

Each quadruplet of poles with corresponding zeros form a single fourth order all-pass section. Since  $H_{LP}(z)$  is a half-band filter, the fourth order section is of the form:

$$A_m(z) = \frac{a_{m4} + a_{m2}z^{-2} + z^{-4}}{1 + a_{m2}z^{-2} + a_{m4}z^{-4}}, \quad m = 0, 1, \dots, l. \tag{6}$$

The fourth order section  $A_m(z)$  can be realized with only two multiplications [1, 4].

If the filter is realized as a connection of the second order sections, structure of each section (apart from the sections that correspond to the real axis and imaginary axis poles) is:

$$A_m(z) = \frac{a_{m2} + a_{m1}z^{-1} + z^{-2}}{1 + a_{m1}z^{-1} + a_{m2}z^{-2}}, \quad m = 0, 1, \dots, 2l. \tag{7}$$

It should be noted that  $a_{m1} \neq 0$ , thus minimum number of multiplications is two [1, 4].

Two imaginary axis pair of poles (and a pair of two real poles for  $N_0 = 4l + 4$ ) form a second order section(s):

$$A_{I,R}(z) = \frac{a_{I,R2} + z^{-2}}{1 + a_{I,R2}z^{-2}}. \quad (8)$$

Both sections can be implemented with a single multiplication.

Each section (second or fourth or  $N_0$ -th order) can be realized as a direct form (direct form I), direct canonical form (direct form II), transposed direct form (transposed direct form I) or transposed direct canonical form (transposed direct form II). Alternatively, scheme with reduced number of multiplications [1, 4], Fig. 8 can be used. For the all-pass filter of order  $N_0$ , the minimum number of multipliers is  $N_0$ . Since the filter  $H_{LP}(z)$  is a half-band filter, every second coefficient of the all-pass branch is zero. Therefore, the number of multipliers is reduced to  $N_0/2$ . Forth order section (6) can be realized with only two multipliers  $a_{m4}=a_4$  and  $a_{m2}=a_2$ . Second order section given by (8) can be implemented with only one multiplier  $a_{I,R2}=a_1$ .

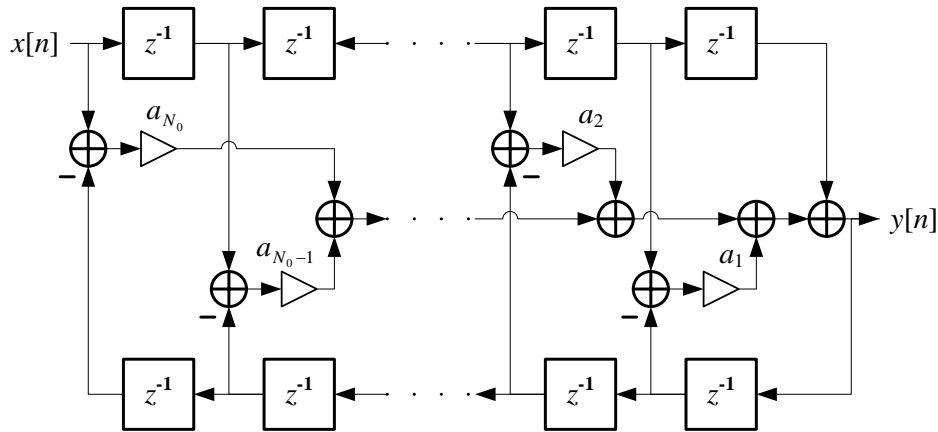

**Fig. 8** All-pass filter structure with minimum number of multiplications ( $N_0=4$ )

## 5. ANALYSIS OF THE HALF-BAND APPROXIMATELY LINEAR PHASE IIR FILTERS

The structure presented in Fig. 1 (parallel connection of two all-pass branches) should be considered as a “classic” structure (along with cascaded and parallel realizations) but MATLAB FDA Tool does not have direct support for this type of the design. It means that a FDA Tool can’t be used for the design of the filter. Instead, the filter should be designed in MATLAB and imported into the FDA Tool. It can be done if the filter is constructed as an object, because MATLAB FDA Tool can import the filter object from the currently active workspace. For that reason, the filters were designed in the conventional way and obtained the coefficients of the denominator of the non-trivial all-pass branch  $A_0(z)$ . For both algorithms, three filter objects were constructed, one for the direct implementation, one for the cascaded connection of the second order sections and last for the realization with second and fourth order sections. Unfortunately, it is not possible to perform quantization analysis by using the FDA Tool for the cascaded or



parallel structures that were not designed in FDA Tool. This means that the user has to set filter object properties in MATLAB. Example filter is a parallel connection of an all-pass branch of order  $N_0 = 12$  and a pure delay of  $N_1 = 11$  samples. The filter  $A_0(z)$  can be implemented as a direct structure, cascaded connection of 12 second order sections or as a cascaded connection of two second order sections and 5 fourth order sections.

The filter  $A_0(z)$  was defined as the all-pass filter, assuming realization based on Fig. 8 with minimum number of multipliers [1, 4]. There is another benefit of the all-pass filter implementation with reduced number of multiplications. When the all-pass filter is implemented as in Fig. 8, the last coefficient of the numerator polynomial remains exactly one. For all other implementation variants, this coefficient usually is rounded to the nearest value allowed by the chosen quantization parameters. For example, if the coefficients are coded as two's complement numbers with 15 fractional bits, 1 will be rounded to the value  $1 - 2^{-15} = 0.999969482421875$ . However, for all-pass filter type, arithmetic property of the filter object can't be set to "fixed". For the analysis of the quantization effects, it is not essential to implement filter with as few multipliers as possible. Therefore, we changed our design to direct form I. We defined filter object properties related to the fixed-point arithmetic, Fig. 9. At the end, we made a parallel connection of  $A_0(z)$  and a pure delay, and add scaling factor 0.5.

```
H=dfilt.dfl(fliplr(A),A);
H.Arithmetic='fixed';
set(H,'OutputWordLength',16,'OutputFracLength',15);
set(H,'CoeffWordLength',16,'CoeffAutoScale',0);
set(H,'NumFracLength',15,'DenFracLength',15);
set(H,'ProductMode','SpecifyPrecision');
set(H,'NumProdFracLength',30);
set(H,'DenProdFracLength',30,'CastBeforeSum',CBS);
H2=dfilt.delay(11);
Huk=cascade(dfilt.scalar(0.5),parallel(H,H2));
```

**Fig. 9** Creating filter object, all-pass branch is realized as a direct structure, A is vector of denominator coefficients of the transfer function  $A_0(z)$

```
Hi=dfilt.dfl(fliplr(ci),ci);
...
H2ord=dfilt.cascade(Hi);
Hr=dfilt.dfl(fliplr(cr),cr);
...
addstage(H2ord,Hr);
H2ord2=copy(H2ord);
for br=1:length(nule_rest)/2
    Hc2=dfilt.dfl(fliplr(cc2(br,:)),cc2(br,:));
...
    addstage(H2ord2,Hc2);
end;
```

**Fig. 10** Creating filter object, all-pass branch is realized as a cascaded connection of second order sections; structure, ci, cr, and cc2 are denominator coefficients corresponding to imaginary axis poles, real axis poles and "rest" poles respectively

For the cascaded implementations, the arithmetic properties of the all sections should be set independently. It means that filter object was defined for each section. All-pass

branch  $A_0(z)$  was defined as a new object defined as a cascaded connection of the objects corresponded to all low order sections. In Fig. 10 code for obtaining a connection of the second order sections is presented. Fixed-point arithmetic properties are set in the same way as for the direct realization of  $A_0(z)$ .

## 5. ANALYSIS RESULTS

Analysis is performed in the FDA Tool for approximately linear phase half-band IIR filters obtained by optimization algorithm [8], and for filters obtained by the low-pass filter stop-band zero positioning method. Design parameters for the optimization algorithm [8] are: the filter order,  $N_0=23$ , the pass-band edge frequency,  $\omega_g=0.45\pi$ . Design parameters for the stop-band zero positioning method are: the filter order,  $N_0=23$ , the first stop-band zero frequency,  $\omega_0=0.61\pi$ . Both designs share the same realization structure, Fig. 1. Therefore, for the same filter order, number of the multipliers and number of the states are the same for both structures. In Table 1 results for the number of the multiplications (M) and the number of the states (S) are presented, for the filter order  $N=23$  ( $N_0=12$ ,  $N_1=11$ ), assuming direct form I for all sections. It should be noted that direct form I is not optimal. It requires twice as many multiplications as the all-pass structure. In addition, the number of the states is reduced in the case of canonic structures (direct form II and transposed direct form II).

**Table 1** Implementation costs, M – number of multipliers, S – number of states, direct form I

Structure	M	S
SOS1 - Second order section, real (or imaginary) axis poles	2	4
SOS2 - Second order section (other poles)	4	4
FOS - Fourth order section	4	8
D - Delay (11 taps)	0	11
0.5 constant	1	0
Direct implementation of $A_0(z)$	12	24
$H_{LP}(z)$ – direct impl. of $A_0(z)$	13	35
$H_{LP}(z)$ – 2 SOS1, 4 SOS2	21	35
$H_{LP}(z)$ – 2 SOS1, 2 FOS	13	35

It was shown in [5] that, for the implementation consist of the second order sections only, degradation of the frequency response is larger comparing to other two alternatives. In Fig. 11 gains of implementation based on the second order section are presented for quantized and non-quantized filter coefficients for both algorithms. The quantization parameters are set to: coefficient word-length – 16 bits, number of fractional bits – 15. Assuming two's complement signed numbers, values that can be representing correctly are in  $[-1 \ 1]$  range. In Fig. 11 it can be seen that the filter obtained by the optimization method [8]  $H_{12}(z)$  has equiripple response. For the given filter order, stop-band attenuation is less than 40 dB. Therefore, the quantization error is small (for the specified word-length). Characteristic of the filter obtained by zero positioning procedure [9, 10]

$H_{22}(z)$  has increased stop-band attenuation. For the attenuation values larger than 80 dB degradation of the response is noticeable. In Fig. 12 gains of the low-pass filter  $H_{LP}(z)$  for three different implementation of the all-pass branch  $A_0(z)$  in the case of the design [9, 10] are presented. For all three simulated structures, the degradation for the attenuations larger than 80 dB is similar. For the defined word-length of 16 bits, this effect is expected.

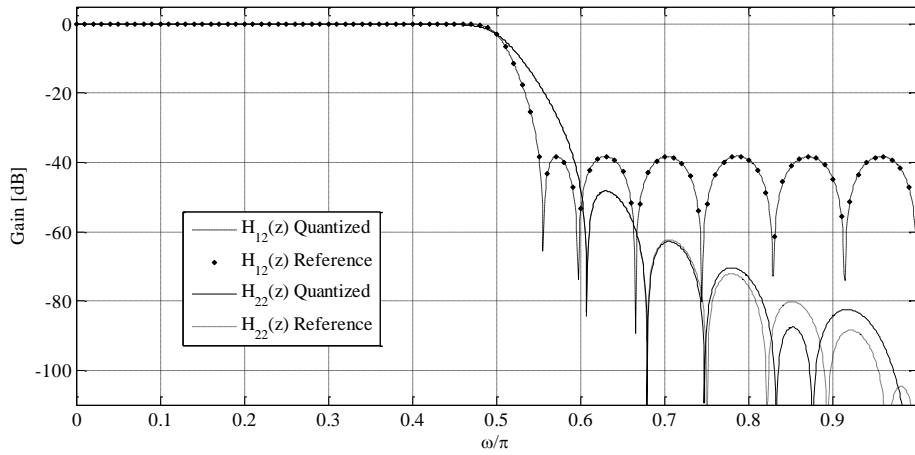

**Fig. 11** The gains of the analyzed filters,  $H_{12}(z)$  – design method based on the optimization [8],  $H_{22}(z)$  – design method based on the low-pass stop-band zeros positioning [9, 10]

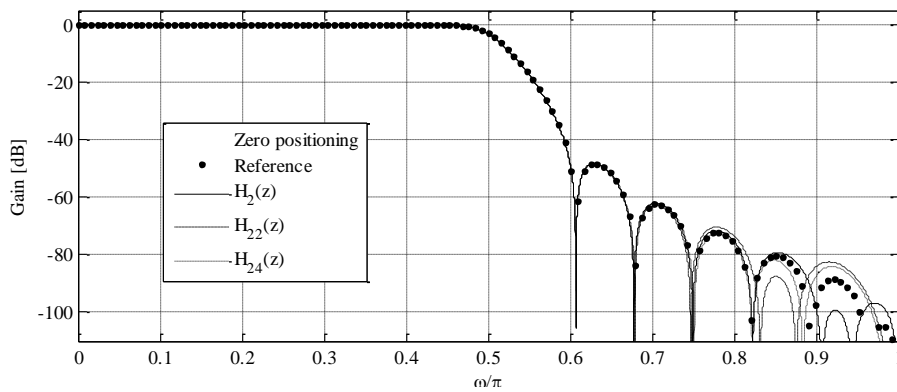

**Fig. 12** The gains of the analyzed filters based on the low-pass stop-band zeros positioning [9, 10], for three different implementation of the all-pass branch  $A_0(z)$ ,  $H_2(z)$  – direct implementation,  $H_{22}(z)$  – cascaded connection of the second order sections,  $H_{24}(z)$  – cascaded connection of the second and fourth order sections

The analyzed structures are approximately linear phase IIR half-band filters. In Fig. 13 group delays are presented for low-pass filters obtained by the optimization

method [8],  $H_1(z)$  and by the low-pass filter stop-band zero positioning method [9, 10],  $H_2(z)$ . In both cases, group delay is approximately 11 samples. In Fig. 14 group delays are presented for the filter obtained by the optimization method [8] for the all-pass branch  $H_{1ap}(z)$  and for the low-pass filter  $H_1(z)$ . It should be noted that the delay of the low-pass filter has smaller variations comparing to the variations of the delay of the all-pass branch.

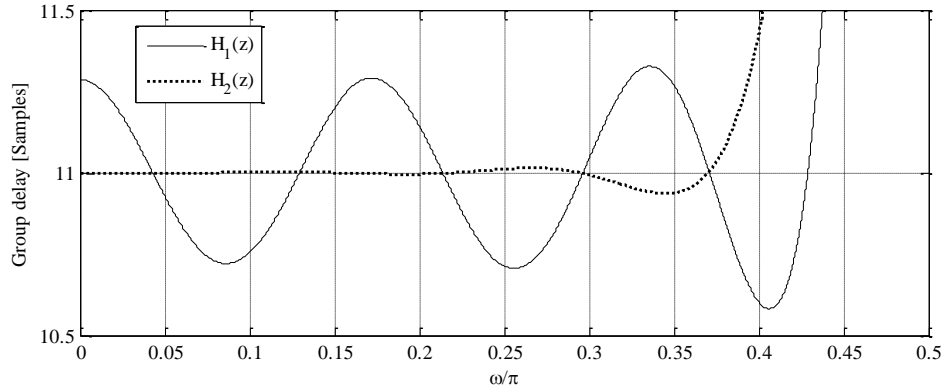

**Fig. 13** The group delay of the analyzed filters,  $H_{12}(z)$  – design method based on the optimization [8],  $H_{22}(z)$  – design method based on the low-pass stop-band zeros positioning [9, 10]

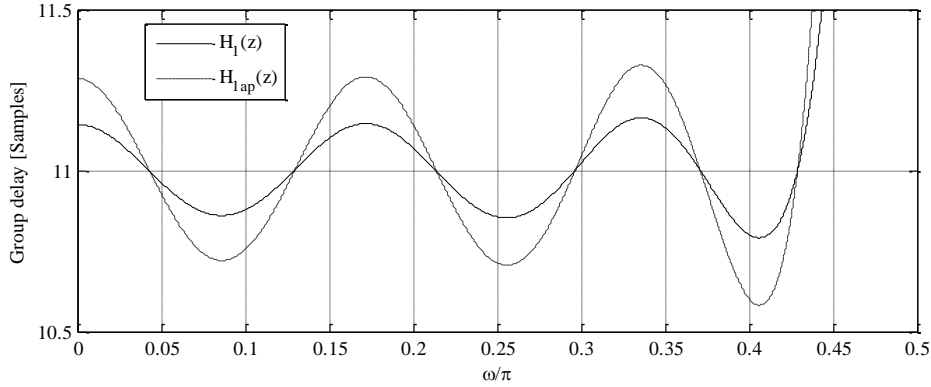

**Fig. 14** The group delay of the all-pass branch  $H_{1ap}(z)$  and of the low-pass filter  $H_1(z)$  designed by the optimization method [8]

## 6. CONCLUSION

In this paper, a possible solution for analysis of the quantization effects and implementation cost using a well known commercially available FDA tool was presented. It was shown that it is possible to use an FDA Tool even in the cases where the filter

structure that was analyzed is not directly supported. Our approach was confirmed by simulation of quantization effects in the case of half-band IIR filter with approximately linear phase. Two different algorithms were used for the design of the filter, one, well-known [8], based on the optimization method, and the other, recently published [9, 10], based on the direct positioning of the low-pass filter stop-band zeros. Implementation structures are the same for both filters, and consist of a parallel connection of the approximately linear phase all-pass branch and a pure delay. For the situation presented in this paper, when the structure is not fully supported in the FDA Tool, the user should be able to set additional parameters manually (by writing the appropriate code). It requires advanced knowledge about different implementation structures, the principles of the simulation of the quantization effect and number representations in the fixed-point arithmetic systems. It can be concluded that it is possible to use the FDA Tool for the analysis of the filters that are not supported, but the process is not as simple as in the case of the supported filters.

**Acknowledgement:** *This work was partially supported by the Ministry of Education and Science of Serbia under Grant TR-32023.*

#### REFERENCES

- [1] M. D. Lutovac, D.V. Tošić, B. L. Evans, *Filter Design for Signal Processing Using MATLAB and Mathematica*, Prentice-Hall, New York, 2001.
- [2] J. D. Čertić and L. D. Milić, "Investigation of Computationally Efficient Complementary IIR Filter Pairs with Tunable Crossover Frequency", *Int. J. of Electron. and Commun. (AEÜ)*, vol. 65, pp. 419-428, 2011.
- [3] J. D. Čertić and L. D. Milić, "On the sensitivity of two-channel IIR filter banks with variable crossover frequency", In Proceedings of the 5th International Symposium on Image and Signal Processing and Analysis, ISPA, Istanbul, Turkey, 2007. pp. 86-91.
- [4] MathWorks, *Fdatool documentation* [Online], The MathWorks, United States, Available: <http://www.mathworks.com/help/dsp/ref/fdatool.html> [Accessed 10 May 2015].
- [5] A. D. Radonjić and J. D. Čertić, "Analysis of Atypical Filter Structures in MATLAB", In Proceedings of the IcEtran, Vrnjačka Banja, Srbija, 2014, EK11.1.
- [6] MathWorks, *MATLAB documentation* [Online], The MathWorks, United States, Available: <http://www.mathworks.com/help/matlab/index> [Accessed 10 May 2015].
- [7] L. D. Milić and M. D. Lutovac, "Design of multiplierless elliptic IIR filters with a small quantization error", *IEEE Trans on Sig. Proc.*, vol. 47, pp. 469 – 479, February 1999.
- [8] H. W. Schüssler and P. Steffen, "Recursive half-band filters", *Int. J. of Electron. and Commun. (AEÜ)*, vol. 55, pp. 377-388, June 2001.
- [9] M. D. Lutovac and A. Radonjić, "Digital halfband IIR filters with approximately linear phase" (in Serbian), In Proceedings of Informacione tehnologije. Žabljak, Montenegro, 2010, pp. 174-177, 2010.
- [10] A. D. Radonjić, "Analysis and Design of Digital filter using algebra software systems", (in Serbian), Master degree thesis, School of Electrical Engineering, University of Belgrade, 2014.