

FACTA UNIVERSITATIS

Series: Automatic Control and Robotics Vol. 14, N° 3, 2015, pp. 159 - 172

ELEVATOR SYSTEM WITH DUAL POWER SUPPLY

UDC (621.876.3:(621.313.3+621.472))

**Tatjana R. Nikolić, Goran S. Nikolić,
Branislav D. Petrović, Mile K. Stojčev**

University of Niš, Faculty of Electronic Engineering, Department of Electronics, Niš,
Republic of Serbia

Abstract. *Modern high-rise buildings require use of a growing number of elevators that have become important factors in energy consumption. Most of the existing lifts are powered from the grid. In order to reduce grid energy consumption and increase reliability, an improved elevator system which uses dual power supply is proposed in this paper. This system supplies electronic modules of the elevator with renewable sources whenever there is sufficient sunlight and maintains usual work of the elevator in case of electricity power failure. The corresponding architecture of the proposed elevator system and needed battery capacity for correct operation are given in this paper.*

Key words: *elevator system, power supply, grid, solar energy, battery, energy consumption*

1. INTRODUCTION

Today, a building's consumption of energy from non-renewable sources and the associated emissions negatively impact the environment. With the rapid development of urbanization, the number of elevators increases dramatically and thus the energy consumption becomes larger. As high-rise buildings continue to grow, the design and control of elevators to transport passengers safely, quickly, and comfortably, still remains a challenging problem, especially in situations when the grid is off. Current elevator systems are becoming more complex, and therefore problems that accompany power supply, communications and software responsibility for providing functionality in these systems, are becoming increasingly evident. To achieve an acceptable system performance, efficient solutions of the aforementioned problems, related to energy saving and reliable operation, are needed. Let us consider now the impact of both these aspects separately.

Energy saving: In recent years, interest in energy saving has been increasing and has caused the development of new devices, technologies and control methodologies in many electro-mechanical applications. In order to reduce power consumption, alternative energy

Received July 15, 2015

Corresponding author: Tatjana R. Nikolić

Faculty of Electronic Engineering, Aleksandra Medvedeva 14, 18000 Niš, Republic of Serbia

E-mail: tatjana.nikolic@elfak.ni.ac.rs

sources are used. The question, how to apply the energy saving technology effectively in elevators, imposes itself as a significant problem. There are numerous possible approaches which could be used to build energy efficient elevator systems. These approaches need to be considered during the design, development and manufacturing of the new elevator systems, but also it should be considered which cost effective approaches can be implemented in the already existing elevator systems. However, it is difficult to evaluate energy saving performance using standard methods because the energy consumed by each individual elevator greatly varies due to its type and technical specifications [1]. An elevator with a renewable energy storage system possesses a superior energy saving performance. Such system stores renewable energy when it is available, supplies the elevator when needed, and maintains the optimal work of the elevator in case of electrical power interruption [2]. Such solution requires complex control logic which can be commonly implemented by an embedded computer (by both hardware and software).

Reliable operation and architecture choice: A crucial functional requirement of embedded computer based systems is related to reliability. Let us note that a very important aspect of system reliability is a segment of the power supply. In general, such systems require power supplies that are safe and reliable [3]. Modern electrical power supply systems are implemented as large and complex networks composed of generators, transformers, distribution lines, capacitors, and other devices. A power supply system has to provide high quality of electrical energy to the user instantly, constantly, and exactly in the amount which is needed.

Selection of efficient power supply architecture is significant for both cost and performance. An acceptable solution of the power supply system can be obtained by an appropriate selection of its building blocks (power converters, inverters, etc.) and suitable architecture choice. Typically, the power supply architecture can be implemented either as central or distributed one. The usage of distributed power architecture in various complex electronic systems is preferable due to numerous reasons, such as reduced distribution distance, better dynamic performance and the ability to use standard hardware. Distributed power supply architectures replace multiple central power sources with a single bulk supply voltage which is converted to the end use voltages by DC/DC converters located at the point of need [4].

A sudden failure of the power supply in elevator systems causes the stop and capture of the elevator between floors. Therefore, there is a need for mechanism which can allow rescue of passengers from the inside of the elevator. This mechanism releases the brakes and positions the lift at any floor so that passengers can come out by opening the door. Typical solutions are based on usage battery as a back up supply charged by the grid. When there is power failure, back up supply turns on, completes the elevator travel and lands the elevator cabin. To minimize battery power usage it is necessary to determine in which direction the elevator should move (up or down) to the nearest floor. Moving of the elevator is controlled by the electrical drive system. The motor used in the electrical drive is either a direct current (DC) motor or an alternating current (AC) motor. The advances of power electronics combined with a remarkable evolution of microprocessor based control have influenced the increasing usage of AC motor drive.

The main goal of this paper is to optimize the power supply and the control drive system in order to achieve energy efficiency and reliability. To improve the energy saving performance, for supplying electronic modules in the existing elevators, as a novelty we propose to partially replace the usage of grid energy, as the main energy source, with a renewable source (sunlight in our case). This solution requires involving control logic

(embedded microcontroller) which can switch on and off one of the available power sources (grid or battery). To solve the problem of a sudden failure of the power supply in elevator systems we propose usage of battery back up supply based on renewable energy. In our proposal the battery is continuously charged by the solar panel instead of the mains power as in conventional solutions. Thanks to the embedded software, the control system determines in which direction the elevator should move (up or down) to the nearest floor in order to minimize the battery power usage and thus to increase the system reliability.

2. ELEVATOR SYSTEM

What defines standards for elevators: Various building standards define guidelines for planning and building an elevator system, especially related to network design and cabling systems. They specify minimum requirements for communication and power infrastructure of data centers and machine rooms and propose rules for the following segments of the system: infrastructure architecture, electrical design, environmental and mechanical design (HVAC- heating, ventilation, and air conditioning), system redundancy and infrastructure, cabling systems, access control and security, environmental control, power management and protection against physical hazards (fire, flood, windstorm)[5]. In accordance with the standards, in the design phase of elevator systems and during the modification of the existing solutions, it is necessary to consider the following: a) machine type, b) loading capacity, and c) hoist drive system.

Type of elevators: There are many types of elevators that are currently used, and their classification is usually based on the principle of running the cabin. The two main types of elevators are traction and hydraulic and they are described in [6]. The type of elevator which is most commonly used is the traction elevator on the rope which is called an elevator driven by electric motors. In this type of elevator the cabin is moved up and down with wire ropes. Ropes are attached to the cabin elevator and wrapped around the drive pulley - sheave. A pulley has a number of grooves in the scope in which ropes are put. Turning a pulley leads to the withdrawal of a rope to one side or the other, or the cabin up or down. A pulley is mechanically linked to drive electric motor through the gear system. There are solutions to drive a pulley without gear. In this case a special type of motor runs a pulley directly. Geared elevators use standard induction motors while gearless elevators use synchronous motors. Inverters that drive gearless elevators are required to be small, thin, to have high overload capacity, and to deliver high performance and high functionality (to be powerful and high performance). Geared traction elevators are used for medium-speed applications up to 2.0 m/s. Typically, a pulley, motor and control system are located in the machine room above the elevator shaft [7].

In this paper the low-speed traction elevator which uses a driving induction motor fitted with a reduction gear will be analyzed. This type of elevator is widely used as a standard type of elevator in medium or low-rise buildings. Loading capacity is a function of the desired platform size and/or the maximum weight to be moved. The motor is chosen depending on the requirements of the elevator. In order to increase the motor efficiency, the control of the primary voltage applied to the induction motor can be continuously improved using different methods. Great progress was made in the technology with using power transistors suitable for applications that cover a *variable voltage variable frequency* (VVVF) control method, i.e. a control method based on inverter [1]. The required power needed for cabin moving includes

the power to overcome static or stationary friction and the power to accelerate the mass from the stop point to full speed. Considerations that must be included in the choice of the available motor deal with both correct speed regulation and starting torque.

Electric drive: An electric drive is a system which performs the conversion of electric energy into mechanical energy at adjustable speeds. This is the reason why electric drive is also called adjustable speed drive (ASD). Electric drive has three main components: electric motor, power electronic converter, and drive controller. Moreover, electric drive always contains a current (or torque) regulation in order to provide safe current control for the motor. Therefore, electric drive should be able to follow the torque/speed characteristic that depends on the mechanical load. This ability of the motor to match the mechanical load leads to better energy efficiency and lower energy dissipation. In addition, during the transient period of acceleration and deceleration, electric drive provides fast dynamics and allows soft starts and stops. In other words, the selection of the induction motor should be performed in accordance to the load in the elevator systems. A growing number of applications require that the torque and speed have to vary in order to match the mechanical load. The increased number of services that elevators provide to users causes the issuing of new requirements that drive system should fulfill [8].

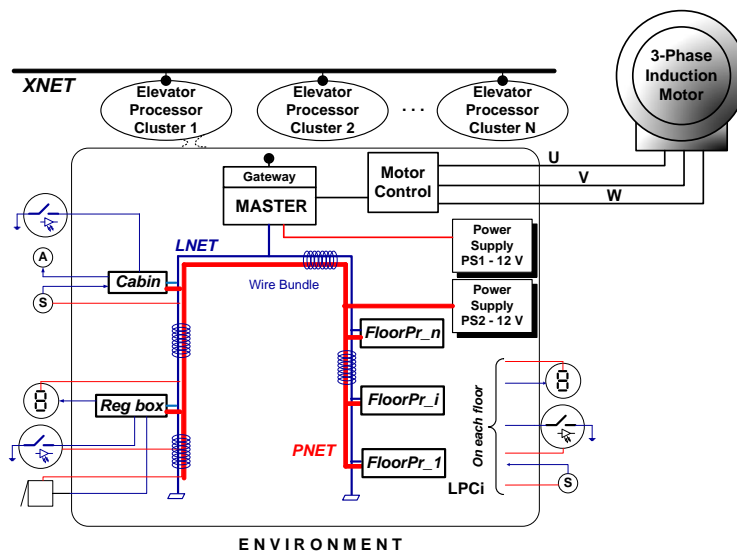

Fig. 1 Global structure of the elevator system

Elevator structure: Global functional structure of an elevator system which is analyzed in this paper is illustrated in Fig. 1 [9]. It is a conventional elevator system. The structure is composed of a number of elevator processor clusters, EPC_i , $i = 1, \dots, n$. All clusters have identical architecture and are mutually connected by XNET bus based on RS485 interface. Having this in mind, in the remaining part, we will analyze the principle of operation of a single elevator unit, i.e. the elevator processor cluster. As can be seen from Fig. 1, the processing of the elevator processor cluster is distributed among several processor nodes. Processor nodes are connected via LNET bus using RS485 interface. The elevator processor cluster is composed of the following processor nodes:

- Master node – directly controls most actuators in the system (motor, valves, brakes, and others);
- Cabin node – acquires all information needed for moving the cabin and for automatic door control;
- Register box – collects requests from passengers in elevator and displays the necessary information;
- n Floor processors, one per each floor.

The Gateway as a building block of the master connects EPC to XNET bus. PNET is a power distribution bus.

3. ENERGY REQUIREMENTS

In order to design an efficient energy management strategy of the elevator system, or to perform a modification in the existing solution, it is necessary to evaluate the overall energy consumption. Among various modules, the one that consumes the greatest amount of power is the hoisting motor which raises and lowers the weight which balances against the weight of the cabin. The next module is the electromagnetic brake that prevents the hoisting device from rotating, followed by the door motor which opens and closes the cabin doors.

Energy consumption of the elevator system varies according to the specifications of its building blocks and cabin occupancy. These issues differ greatly from one building to another, and change over time, so it is difficult to evaluate the energy saving performance of elevators indifferent buildings by using a single specific representative approach. Also, in order to effectively reduce the energy consumption under a variety of working conditions, it is necessary to combine multiple methods [1].

In the elevator system considered in this paper the main power (induction motor) and the ancillary power (control units, lights, fans, alarms, CCTV, displays, etc.) are supplied by separate feeders. The main power is related to the power required for driving the motor, while the ancillary power is related to the electronic modules necessary for operation, monitoring and control of the elevator system.

Main power: When the grid is used as a power supply source, then a typical solution for the motor drive system requires a simple front end rectifier and a fixed voltage intermediate DC bus which isolates mains current from current of the motor. One modern concept, shown in Fig. 2, is based on switching the power supply at the front end (AC/DC power converter). This solution provides stable power supply voltage and reduction of conversion loss, i.e. the reduction in power consumption is achieved. On the back end side, the voltage source inverter is used to invert the DC signal (available on the DC bus) into AC signal of variable frequency and variable voltage. It consists of six electronic switches which are switched on/off by pulse width modulation, PWM, control signals, in order to create AC output voltages [10]. The energy which a switching power inverter delivers to a motor is controlled by PWM signals applied to the gates of the power transistors. The control of the inverter is required in order to create three sinusoidal current waveforms in the motor windings, with relative phase displacements of 120° . Firstly, the inverter control should be efficient, and secondly, it is intended to improve the power factor of the power source [1].

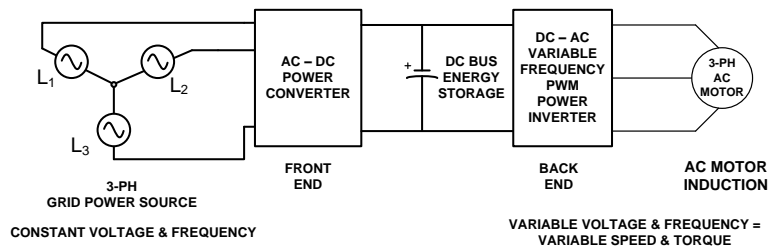

Fig. 2 Basic concept of the motor drive system

Ancillary power: In addition to the energy needed for supplying the motor drive system, the ancillary energy is needed for supplying other electronic modules. Let us note that these modules consume energy even when the elevator cabin is not moving (i.e. in idle state). Numerous floor processors and cables losses have a dominant impact on energy consumption in the elevator system with one cabin which covers many floors. By using a microprocessor/microcontroller as a control circuit in an elevator system, the control performance can be greatly improved, and energy saving can be achieved, too. Such solutions offer support and advantages in the field of accuracy and speed, which are needed in modern high end inverters controls. The next important advantage is the flexibility inherent in any digital controller, which allows designer to modify the control strategy, or even to totally reprogram it, without the need for significant hardware modifications.

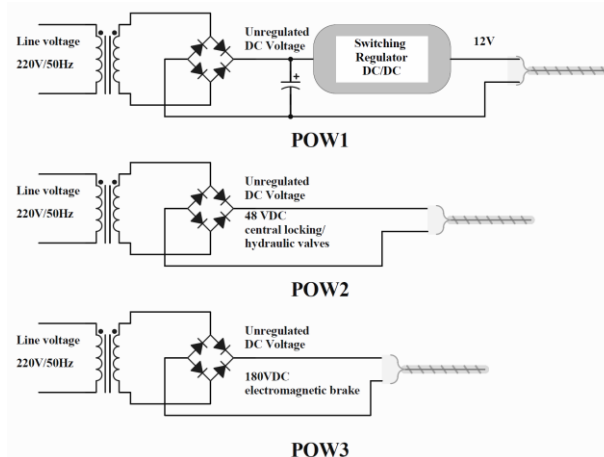

Fig. 3 Typical voltage values of the elevator system

Overall, in accordance with the classification given in the previous section of the paper, an elevator system has requirements for different ancillary power supply voltage levels (see Fig. 3). Power supply for electronic modules consists of three parts. First unit, marked as POW1 is used as DC power supply for elevator processor electronics. It provides supplying for all sensors and actuators. Second unit, labeled POW2, is an unregulated and unfiltered power supply unit and is used for controlling the central locking system; it typically drives a solenoid in the case of opening manual or semiautomatic doors. This power supply unit can

be used in hydraulic elevators for driving valves. Finally, unit POW3 is used to drive the electromagnetic brake that is energized during the elevator movement.

As can be seen from Fig. 1, block power supply, PS1, is of type POW1, and supplies the Master node, while the PS2 supplies nodes Cabin, Register block and Floor processors, and is also of type POW1.

4. ELEVATOR SYSTEM WITH DUAL POWER SUPPLY

In order to improve energy saving performance in the existing conventional elevators, i.e. to reduce energy consumption from the grid, and to ensure the continuous operation of the elevator in case of power failure, we propose the use of solar energy. In autonomous buildings the elevator system can operate by using a grid and photovoltaic energy. Our aim is to supply the elevator with as much solar energy as possible, and to make use of solar energy for various purposes. The proposed elevator system with a dual power supply is presented in Fig. 4.

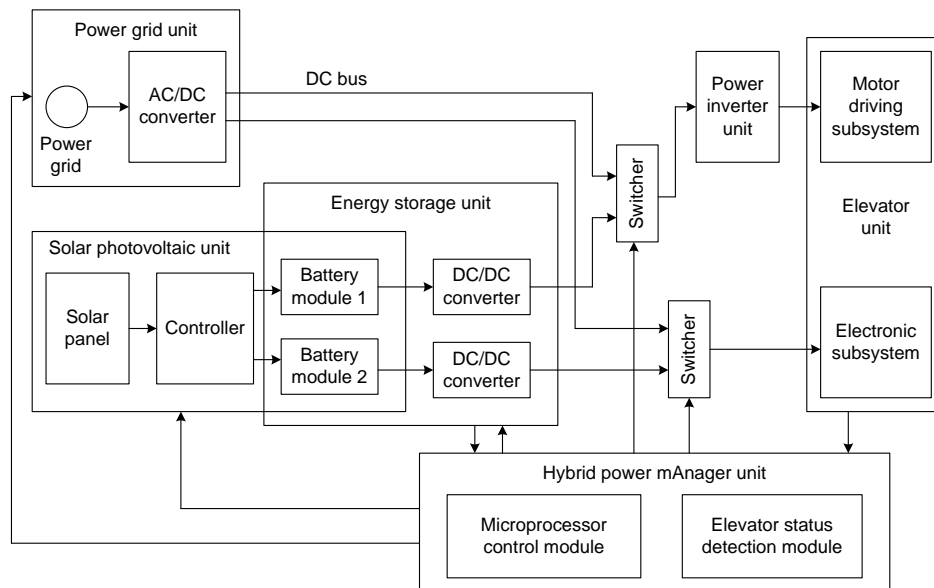

Fig. 4 Elevator system with dual power supply

The elevator system includes the following: a) Power grid unit; b) Solar photovoltaic unit; c) Energy storage unit; d) Power inverter unit; e) Elevator unit; and f) Hybrid power manager unit. The Power grid unit comprises AC/DC converter next to Power grid, while Energy storage unit includes Battery modules 1 (2) and accompanied DC/DC converters. The Elevator unit consists of Electronic subsystem and Motor driving subsystem. Both subsystems can be independently powered in two ways. The appropriate power supply mode is switched on or off by the Hybrid power manager unit. This unit controls the flow of energy and enables dual power supply mode of operation. It consists of Microprocessor control module and Elevator status detection module.

The Electronic subsystem is composed of electronic modules needed for operation of the elevator system. It gets energy from the Energy storage unit if this unit has enough energy which can raise the DC bus voltage. This mode of power supply is active until energy of the Energy storage unit exceeds AC/DC converter voltage. The second power supply mode is automatically switched according to the status of the Energy storage unit. Namely, if the energy from Energy storage unit is insufficient for supplying the Electronic subsystem then the needed energy can automatically be obtained from the Power grid unit. By using solar energy, whenever possible, significant energy saving can be achieved.

The Motor driving subsystem comprises the AC motor drive based on Power inverter unit (DC/AC converter). The basic component of the Power inverter unit is the electronic switch which is fully controllable (controllable on-state and off-state) and based on the IGBT (insulated gate bipolar transistor). The Motor driving subsystem gets energy from the Power grid unit or Energy storage unit. The usage of solar energy can be automatically achieved only when the power grid breaks down. In this way, the reliability of elevator system can be improved.

Whenever sunlight is available, the batteries are charged with solar energy which provides continuous batteries charging.

5. MOTOR DRIVING SUBSYSTEM

Operation of the elevator system in normal mode exists when the Motor driving subsystem is supplied by grid. In this mode, the Power inverter unit is connected to the Power grid unit (see Fig. 4). In case of power failure, the Hybrid power manager receives information about it and connects the Power inverter unit to the Energy storage unit, i.e. Battery module 1. This module should provide the elevator to move to the nearest station and open the door automatically. If the power failure happens whilst the elevator is in motion, the elevator first stops, usually out of the station. In time of brake opening, the Hybrid power manager has to pick out the optimal direction of motion – full cabin goes down, empty goes up. The optimal direction is selected in order to be able to use the battery with smaller power capacity, because the energy is needed only to overcome friction and braking [11].

Selection of an optimal motion direction of the elevator depends on the ratio between weight of the cabin with the load and weight of the counterweight in the following way:

- if counterweight > cabin with load then the lift is moving upward
- if counterweight < cabin with load then the lift is moving downward

In accordance with the preceding, the Hybrid power manager, at any time, requires information about the weight of the cabin with the load.

Electrical input power of the motor depends on voltage, current and power factor, and it is defined by the following formula:

$$P_{in} = \sqrt{3} \cdot U \cdot I \cdot \cos \varphi \quad (1)$$

The output power of the motor is equal or less than electrical input power and depends on the motor efficiency, η , and can be defined as:

$$P_{out} = \eta \cdot P_{in} \quad (2)$$

Determining the output power of the motor needed for the motion of the elevator is a problem that requires collaboration between the mechanical and electrical models of the system. In that sense, there is a necessity for a detailed study of elevator kinematics motion, which represents the basis for electric drive system [12]. For this reason, we will consider a simplified elevator model in the sequel. Fig. 5 shows the block scheme of an elevator which consists of elevator cabin, counterweight, drive pulley, and hoist rope. In order to derive a mechanical model, the following assumptions are made: 1) the elevator is driven by a single hoist motor coupled to the drive pulley; 2) during up and down movements of the cabin and counterweight, the hoist rope that wraps around the drive pulley is inextensible; 3) drive pulley is frictionless [13].

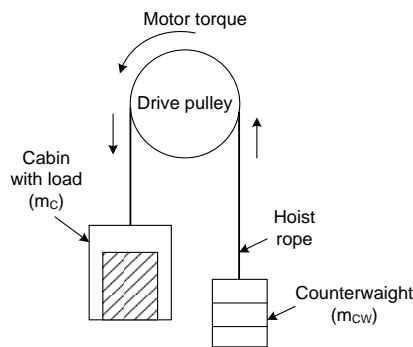

Fig. 5 Simplified model of the elevator

A speed reduction gearbox is located between the motor and the load in order to match the drive to the load. When a gearbox is fitted between the motor and the drive pulley, it has an effect on the torque, speed and inertia. Thus the rotational speed will be reduced, and the torque will be increased. This effect is useful since the rotational speed of most motors is too high to directly drive the load, while the torque is too low.

The main requirements of the elevator system are directly related to the shape of the speed curve, as shown in Fig. 6. The elevator should increase the speed slowly after it starts and reduce the speed gradually before it stops in order to avoid vibration. The speed characteristics in terms of time shown in Fig. 6 can be divided into three phases. First, the motor is rapidly accelerated with high torque to a constant speed, at which only small torque is required. After that, high braking torque is required to rapidly decelerate the motor into the desired position. The speed of the motor must be altered smoothly to avoid jerking. The speed pattern is generated accurately as a function of the position of the elevator cabin [7, 14].

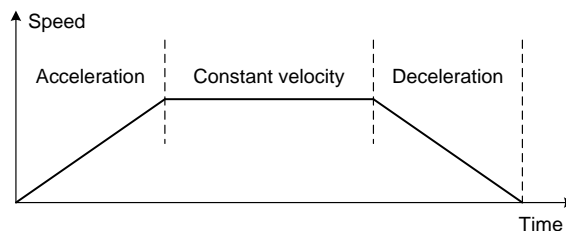

Fig. 6 The speed-time characteristics of the elevator

The output power of the motor needed for elevator motion can be calculated using the following formula:

$$P_{out} = T_m \cdot \omega_m \quad (3)$$

Where T_m is the motor torque expressed in Nm, and ω_m is the angular speed of the rotor expressed in rad/s. The motor torque can be considered through a dynamic and a load component in the following way:

$$T_m = T_{dyn} + T_{load} \quad (4)$$

The dynamic torque component caused by acceleration/deceleration of motor with a constant moment of inertia expressed as:

$$T_{dyn} = J_m \cdot \frac{d\omega_m}{dt} \quad (5)$$

where J_m is the moment of inertia of the motor.

The load torque consists of friction, inertia of the moving parts and the load itself. In order to derive the load torque equation, we assume that the mass of the drive rope is ignored. The load torque T_{load} that is placed on the drive pulley which is mounted on the motor's shaft is expressed as:

$$T_{load} = J_p \cdot \frac{d\omega}{dt} + F_{load} \cdot r \quad (6)$$

where: F_{load} is the force exerted on the drive pulley; r is the radius of the drive pulley; J_p is the inertia of the drive pulley; and ω is the angular speed of the pulley.

If the elevator cabin is moving upwards the load force is defined as:

$$F_{load-upwards} = g \cdot (m_c - m_{cw}) + (m_c + m_{cw}) \frac{dv}{dt} \quad (7)$$

where: g is the gravitational constant; m_c is the mass of the cabin with load; m_{cw} is the mass of the counterweight; v is the linear speed of the cabin.

Based on the known relationship between linear speed and angular speed for circular motion, the cabin speed expressed in terms of the angular speed of the pulley is:

$$v = r \cdot \omega \quad (8)$$

By substituting eq. (7) in eq. (6), we obtain the equation for the load torque when the elevator cabin is moving upwards in the following form:

$$T_{load-upwards} = J_p \cdot \frac{d\omega}{dt} + r^2 \cdot (m_c + m_{cw}) \cdot \frac{d\omega}{dt} + r \cdot g \cdot (m_c - m_{cw}) \quad (9)$$

In a similar way the equation for the load torque when the elevator cabin is moving downwards is obtained in the form:

$$T_{load-downwards} = J_p \cdot \frac{d\omega}{dt} + r^2 \cdot (m_c + m_{cw}) \cdot \frac{d\omega}{dt} + r \cdot g \cdot (m_{cw} - m_c) \quad (10)$$

To calculate the torque according to equations (9) and (10) it is necessary to know the parameters of the elevator system. It should be noted that the ratio between the linear speed of the elevator (i.e. the angular speed of the pulley) and the rotational speed of the

motor depends on the reduction ratio of the gearbox. Let us assume that, in our case, the elevator system has the following parameters:

- the empty cabin mass, $m_{ec} = 1000$ kg;
- the rated passenger load, $m_l = 1000$ kg;
- the counterweight mass, $m_{cw} = 1500$ kg (the mass of the counterweight is selected as equal to the mass of the cabin, plus half of the mass of the rated passenger load);
- pulley diameter, $r = 0.5$ m;
- moment of inertia of the motor rotor, $J_m = 0.1$ kgm²;
- elevator speed, $v = 1$ m/s;
- motor speed, $\omega_m = 1500$ rev/min.

Let us note that the characteristic of angular speed, ω (see eq. (8)), used in eq. (9) and (10) corresponds to the characteristic of elevator speed in terms of time (see Fig. 6). This implies that there exist three different cases in which the load torque should be determined: acceleration, constant velocity and deceleration. In addition, it should be noted that the service speed is used for the elevator motion, since the grid power supply failure appears. Service speed is usually equal to the quarter nominal speed. When the elevator moves at a constant rate, based on the eq. (9) and (10), it is clear that the load torque is determined taking into account the term which is not depended of derivative of angular velocity, i.e. the last added. In phases of acceleration and deceleration, the elevator speeds up very slowly until it reaches service speed and also slows down very slowly from service speed until it stops. Despite the fact that the acceleration and deceleration have very small values, all members which depend on the derivative of angular velocity cannot be ignored in equations (9) and (10).

Based on the foregoing, the load torque can be evaluated for the following two worst cases of elevator movement: 1) empty elevator cabin is moving upward and passes the entire distance between two floors; and 2) full elevator cabin is moving downward and passes the entire distance between two floors.

For the assumed parameters of the elevator system, taking into account all three phases, the needed power and energy are given in Table 1. The amount of needed energy is calculated during a period of duration of all three phases, namely, acceleration, constant velocity and deceleration, which are equal to 1 s, 10 s and 1 s, respectively.

Table 1 The needed power in Watts and energy in Joule

	Power per phase [W]			Energy per phase [J]			Total energy[J]
	accele- ration	constant velocity	decele- ration	accele- ration	constant velocity	decele- ration	
empty cabin, upward	913.5	1226.25	1538.75	913.5	12262.5	1538.75	14714.75
full cabin, downward	788.75	1226.25	1663.75	788.75	12262.5	1663.75	14715

By analyzing the results presented in Table 1, we conclude that the worst case from aspects of power consumption appears in the deceleration phase when full elevator cabin is moving downward. With the aim to determine the capacity of Battery module 1 which will be satisfactory to move the cabin in the optimal direction, from the stopping point to

the nearest floor, we will take into account the worst case. In our case this corresponds to shaded area in Table 1. In praxis the designers, in order to achieve a safe solution, usually use the approach called “Duplication”. This means that in our case the minimal capacity of Battery module 1 should be 29.43 kJ. By using this approach, the power consumption of the DC/DC converter, power inverter and switcher (see Fig. 4) is included.

6. ELECTRONIC SUBSYSTEM

The energy needed for supplying different electronic modules in the elevator system is obtained from the Battery module 2 whenever there is sufficient sunlight. The Hybrid power manager controls the battery capacity and switches the grid power supply when the capacity falls below a specified level. Required battery capacity can be calculated on the basis of practical measurement of power consumption of the electronic modules of the elevator system presented in Fig. 1. Table 2 shows current consumption for three blocks of the elevator processor cluster, Register box, Cabin and Floor processor for peak current consumption at the constant supply voltage of 12 V. In order to determine the total power consumption for all three blocks, we assume that they include a specified number of corresponding units. It should be noted that the number of Floor processors depends on the total number of floors in the building. In addition, based on practical measurement it is established that current consumption for the Master processor block (Hybrid power manager, DC/DC converter and Switcher) is equal to 2 A at the constant supply voltage of 12 V. This consumption should also be included in the estimation of the total energy consumption. We will consider the worst case scenario of the elevator system installed in a five floor building. Such system includes Master processor block, Register box, Cabin, and five Floor processors, as can be seen in Fig. 7. The total power consumption of the Electronic subsystem is 41.7 W. The power consumption of this subsystem is time

Table 2 Elevator electric modules current consumption

Electric blocks		Units	Current consumption
Register Box	Microcontroller	1	25mA
	Communications Driver	1	500μA (<i>receive</i>)
			900μA (<i>transmit</i>)
	Buttons	16	32mA
	LED Drivers	2	3.0625mA
	LED7SEG	2	106.4mA
Cabin	LED diode	5	60.17mA
	Microcontroller	1	25mA
		1	500μA (<i>receive</i>)
	Communications Driver		900μA (<i>transmit</i>)
		3	150mA
	Relay Actuator	3	150mA
Optocouplers	15	40.90mA	
Floor processor	Microcontroller	1	25mA
	Communications Driver	1	500μA (<i>receive</i>)
			900μA (<i>transmit</i>)
	Buttons	5	10mA
	LED Drivers	2	3.0625mA
	LED7SEG	2	106.4mA
LED diode	5	60.17mA	

independent. The total energy consumption for one hour time period is equal to 150.12 kJ. The vendor battery capacity is expressed in Ah. For our case, if we install a battery of 45 Ah, then the electronic subsystem will be operative approximately 12 h without charging. If the Battery module 2 is on average charged 6 hour per day with 4 A by a photovoltaic system, then the energy supplied by the photovoltaic system is equal to 1.04 MJ. The ratio between the accumulated and supplied energy is 1.9.

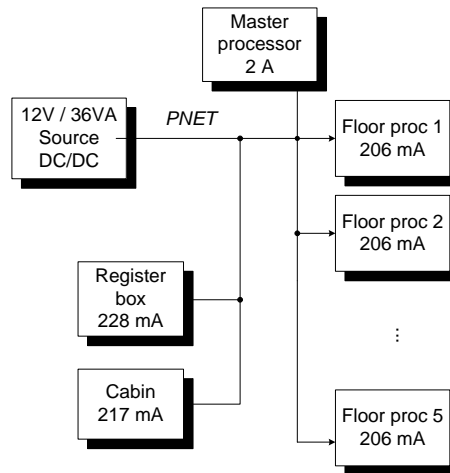

Fig. 7 Block presentation of distributed power supply

7. CONCLUSION

The structure of the elevator system intended for application in high-rise buildings is considered. The main sources of power consumption within the system are identified. The novelty deals with involving a photovoltaic unit as a redundant power supply block. In this context, the elevator system with a dual power supply is proposed. The needed battery capacities for the motor driving and electronic subsystems are determined. By using this solution, reduction in grid energy consumption is achieved and reliability of the system is improved.

Acknowledgement: *This work was supported by the Serbian Ministry of Science and Technological Development, Project No. TR-32009 – “Low-Power Reconfigurable Fault-Tolerant Platforms”.*

REFERENCES

- [1] I. Junichiro, B. Hirokazu, Y. Sakurako, "Energy saving technologies for elevators", Technical Reports, Mitsubishi Electric Advance, vol. 144, pp. 6–10, 2013.
- [2] L. Yao, L. Yanbin, "Simulation and experiment research on a new elevator system with solar energy and super-capacitor", Journal of Software Engineering, vol. 9, no. 3, pp. 534–547, 2015.
- [3] L. L. Pullum, *Software Fault Tolerance Techniques and Implementation*. Artech House Publishers Norwood, MA, 2001.

- [4] Crane Aerospace & Electronics Power Solutions, Designed with a Distributed Power Architecture, Application Note, Rev C-20061206, pp.1–7, [Online]. Available: www.cranae.com
- [5] U. S. Army Corps of Engineers, Technical Instructions, Elevator Systems, TI 810-90, 1998. Washington, [Online]. Available: <http://www.nibs.org/ccb/>
- [6] A. Bhatia, Building Elevator Systems, Course No: A06-001, Continuing Education and Development, Inc., NY.
- [7] N. Tetsuya, K. Hiroaki, "FRENIC-lift Series Inverters for Elevating Machinery, Fuji Electric Review, vol. 52, no. 1, pp. 33–36, 2006.
- [8] ABB drives, Dimensioning of a Drive System, Technical guide, No. 7, 2011.
- [9] B. Petrović, G. Nikolić, "Concept of the high reliability motor drive system for lift", in *Proceedings of 28th International Conference on Microelectronics*, MIEL 2012, Niš, Serbia, pp. 431–434, 2012.
- [10] Philips Semiconductors, Power Semiconductor Applications, Motor Control, pp. 241–315, 2013.
- [11] SEC Electronics, Automatic Battery Evacuation, [Online]. Available: <http://www.sec.si/vsebina/Navodila%20ABR-GB.pdf>
- [12] M. Ungureanu, I. Craciun, D. Stoicovici, "Study for elevator cage position", *Scientific Bulletin Series C: Fascicle Mechanics, Tribology, Machine Manufacturing Technology*, vol. 25, pp. 73–77, 2011.
- [13] M. Schlemmer, S. K. Agrawal, "A computational approach for time-optimal planning of high-rise elevators", *IEEE Transactions on Control Systems Technology*, vol. 10, no. 1, pp. 105–111, 2002.
- [14] J. A. Muhammad, A. L. Shurajji, "Modeling of DC elevator motor drive for mid-rise building", *Engineering & Technology Journal*, vol. 31, part (A), no. 12, pp. 2320–2342, 2013.