



A Security Aspect In Emergency Driving

POTLACHERUVU BABU

M.Tech Student, Dept of ECE
 Avanathi Institute of Engineering & Technology
 Hyderabad, T.S, India

B.BABU

Assistant Professor, Dept of ECE
 Avanathi Institute of Engineering & Technology
 Hyderabad, T.S, India

P.SURESH KUMAR

Associate Professor & HOD, Dept of ECE
 Avanathi Institute of Engineering & Technology
 Hyderabad, T.S, India

Abstract: The general structure is dependent on the AT89S52 microcontroller. Even the key role of DTMF continues to be implied by the aid of which appropriate user can control the safety options of car if it's thievery. The GPS navigation module offers the place to GSM that will further sent towards the user through message. To be able to retrieve the place of car by hand, the consumer will be sending message particularly format on GSM, that will further allows GPS navigation. It's embedded the idea of wireless communication i.e. zigbee and GSM and lots of other sensors by the aid of which immediate help could be shipped to the one who has met by having an accident. Research content uses we've got the technology of signee for that transmission of message to another vehicle within the duration of necessity of their help and for serving the mark of secure driving the functions like motorists alcohol recognition, vehicle speed slowing down and automatic vehicle lock with collision recognition can be used. These studies is essentially with a digital camera that you can use during the time of emergency while worries. The GPS navigation may also be used for locating the exact vehicle location in order that it is available if lost.

Keywords: Accident; DTMF; GSM; GPS; Speed; Vehicle; Signee;

I. INTRODUCTION

The idea of vehicle communication is within existence because of the accidents caused due to human error or by insufficient focus on road while driving or by using sudden brake on front vehicle on streets. Within the past few years, the automobile communication technologies have acquired the recognition in industrial field. Through V2P communication and V2V communication they can be used as the objective of serving security and safety. 14,000 installments of driving under the influence were reported and 45,158 installments of speed over speeding were report only in capital Asia [1]. Although the survey of indianexpress.com 16 deaths and 58 streets injures are reported in India in each and every hour with discussing of fatal accidents within the total being up from 18 percent in 2003 to 25 in 2012". With another statistics by occasions Asia, total vehicle robberies are 40 per day within the capital Asia only. Using the vehicle communication onboard the automobile thievery will reduce considerably because owner can achieve the automobile location simply with the assistance of vehicle communication. As reported by the previous functions by Dr.S.S.Riaz Ahamed i.e. the function of Sigsbee technology later on data communication system" briefs about how exactly the implementation of the technology could be embedded with various aspects for much better outcomes [2]. Even the work by Soyounng Hwang and Donghui Yu describes the Remote Monitoring and Controlling Systems concept According to Sigsbee Systems and also the basics of micro-

controller formula design continues to be analyzed from "The 8051 microcontroller and embedded system" by Muhammad Ali Mazidi, Janice Gillispie Mazidi, Rolin D. McKinlay with this research whereas the necessity of this kind of device for that society is communicated through the previous work of v2v communication survey. Also the thought of the safety within the automobiles continues to be achieved in the work of Rens van der Heijde in the reference Security Architectures in V2V and V2I Communication and also the idea for the style of such advance device continues to be considered in the Burns, J. M., & Nicastri, P. R. (1998). Generation x automotive electrical energy system architecture: Issues and challenges. Within our work the fundamental difference may be the mixture of all of this pointed out technology onboard by the aid of AT89S52 by which in less expenditure we are able to combine all technology and may assist the society by having an advanced device for his or her vehicle

II. PREVIOUS WORK

Sigsbee technology is standard wireless based technology produced for the needs with regard to added inexpensive. It is extremely appropriate for the greatest communication techniques. Sigsbee can also be known to as WPAN. Sigsbee enables you to set small communication network inside an area. Sigsbee is founded on IEEE 802.15 standard technology. Sigsbee is similar to Bluetooth technology whose portion of communication could be 20 meters with kind of sight communication with low power consumption. Sigsbee communication range might be elevated around

100 meters wealthy in power consumption. Sigsbee concentrates on 2.4 GHz RF to maneuver reliable and easy to use standard around the world. Sigsbee network use mesh network with 128 bit symmetric file encryption keys. The transfer rate of Sigsbee is all about 250 kbps that's very suitable for intermittent data transmission from input items like sensor. Sigsbee nick include radios and microcontroller that have 60 - 256 kb flash memory. Sigsbee has integrated battery with battery existence having a minimum of 24 several weeks with certification. You'll find three types of Sigsbee are available obtainable in global market namely Sigsbee coordinator, Sigsbee router and Sigsbee finish items. GPS navigation (GPS navigation navigation) can be a network of satellites that transmit data, which you can use to acknowledge precise location in the world by calculating the area from 24 satellites [3]. Within the object is accumulating by four or maybe more satellites kind of sight and also to have the ability to provide errorless location using GPS navigation satellites which moves across the earth two occasions every day. GPS navigation have two type 2D through which only three satellites are necessary to supply latitude and longitude as well as other is 3d, that four or maybe more satellites are require to provide altitude also. The GPS navigation module which we are using inside the studies EM-506 which has superior sensitivity and satisfaction in even urban foliage atmosphere. The GPS navigation module provides the spot to GSM which will further sent for the user through message. To have the ability to retrieve the area of vehicle manually, the customer is going to be delivering message particularly format on GSM, which will further enables GPS navigation. After being able to view the area the GPS navigation will let known the user's vehicle location. The GPS navigation will also get activate on accident which will transmit the car spot to nearest police station and hospital and permitting these to understand that there's vehicle crash.

III. IMPLEMENTATION

The infrastructure within the method is on AT89S52 microcontroller. The machine has two phases. Within the first phase being used by hand began track of the consumer along with the device formula will begin searching for that collision by the help of flex sensors therefore the cycle will move for your Decoder getting multiple assets connected from it like Alcohol sensor, Sleepiness sensor that will think about the sleepiness quantity of the motive pressure combined with the speed limiter set pre by hand within the device to make certain when others is driving the vehicle he cannot mix the advantage set using the automobiles owner after which it'll shift for your checking of manual key i.e. when the finish outcome is either pressed

using the user otherwise just in case of emergency it'll activate the GSM module that will further send the data for that police station "100" and nationalized ambulance service"108". Just in case within the collision within the vehicle with any tree or vehicle the machine will generate an Interrupt INTO that will further make the signee module which include it and nearby going automobiles will most likely know about the problem happened in their area and may conserve the person. The decoder is further attached to the buzzer and vehicle turn off device and so the device will most likely be switched off or maybe a security will most likely be triggered reminding the motive pressure not to drive the vehicle as they is drunk or feeling sleepy [4]. Plus the issue of manual switch a GSM module remains mounted on make certain any time the client will require help of medical aid or police they are able to push this button and so an instantaneous support will most likely get to him because the message will most likely be send on their own account correspondingly. Whereas within the second cycle within the device that's essentially a crook flow i.e. once the user wants to control the vehicle within the distance he or she must call the DTMF number which include the machine and so the device will most likely be began up then when the machine will began up GPS navigation will most likely be triggered then by pressing the very best command shown to the client only i.e. switching the lock of vehicle or decrease the speed to have the ability to send the region they are able to press the button within the DTMF package he's. By which TIMER0 interrupt will activate and so the microcontroller processes along with the user may use this product.

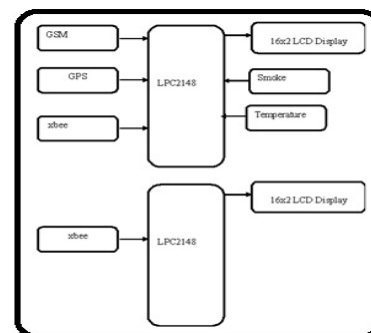

Fig.1. Block diagram of Main vehicle & Monitoring vehicle

IV. ENHANCED WORK

Because the new path for vehicle is opened up in field of communication, the safety by itself and passenger continues to be elevated. Just in case of car lost or thievery, it's possible to simply send a note into it and request its location. Accident aware of nearest help center, road condition warning etc. belongs to the security of passenger. The health of overtaking accident could be overcome with the

vehicle to vehicle communication. Warning of vehicle failure could be sent through the wireless communication area so the accident could be avoided [5]. Using the advancement within the vehicle to vehicle communication, the applying could be rise in our daily existence. A few of the advancement is utilization of radar or sonar sensor rather than pressure sensor. By using radar and sonar sensor, the automobile can act based on the situation, atmosphere and landscape. The expansion goes in further advancements so the vehicle can communicate to as much as possible simultaneously.

V. CONCLUSION

Vehicle to Vehicle Safety Product is an instrument indulge while using recent technology and includes the methodology using the combination of signee, GSM and a lot of other modules by the assistance of which immediate support might be given to anybody searching for this. This project is microcontroller based project .Included in Included in looking in the analysis circuits and programs were simulated on Micro vision 4 Kiel, Hardware implementations are transported out using PCB designs and EXPRESS PCB. In this particular paper a brief description is provided with the medium of Block Diagram and Flow diagrams combined with the introduction of technology. The results and implementation continues to be spoken about here.

VI. REFERENCES

- [1] Xu, Q., Mak, T., Ko, J. and Sengupta, R., Vehicle-to-vehicle safety messaging in DSRC. in Proceedings of the first ACM workshop on Vehicular ad hoc networks, (2004), ACM Press,19–28.
- [2] “The 8051 microcontroller and embedded system” by Muhammad Ali Mazidi, Janice Gillispie Mazidi, Rolin D. McKinlay ISBN-13: 978-0131194021.
- [3] Hubaux, J.-P., Capkun, S. and Luo, J. The security and privacy of smart vehicles. IEEE Security and Privacy Magazine, 2 (3). 49–55.
- [4] J.Wason and J.Wen, “Robot raconteur: A communication architecture and library for robotic and automation systems,” in Proc. IEEE Int. Conf. Robot. Autom. (ICRA), Trieste, Italy, Aug. 2011.
- [5] F. Burget, A. Hornung, and M. Bennewitz, “Whole-body motion plans for manipulation of articulated objects,” in Proc. IEEE Int. Conf. Robot. Autom. (ICRA), May 2013, pp. 1656–1662.

AUTHOR’S PROFILE



Potlacheruvu Babu received the Bachelor's degree in Electronics and Communications from Ellenki Engineering College in 2014.

B.Babu; assistant prof. Received the Masters of Technology degree in ECE in Vardhaman Institution Of Technology From JNTU HYD. He received the Bachelor of Degree in Bandaru Srinivas Institute of Technology Hyderabad. He is currently working as Assistant professor of ECE in Avanthi Institute of Engineering and Technology Hyd. Experience 4 Yrs, His interest subjects are Microwave Engineering(including lab) and Electro magnatic Theory..etc



P. Suresh Kumar is an Associate Professor. He completed Bachelor's degree in Electronics and Communications from JNTU, Ananthapuram. And also completed Master's Degree in Digital system & Computer Sciences from Sreenidhi Institute of Science and Technology, Hyderabad. His favourite subjects are EDC,DC,ECA, Digital Systems.

