

# The Design of the Telemetric System for Recording Operating Parameters of Electric Vehicles

Piotr Tomczuk, Andrzej Czerepicki, Marcin Koniak, Piotr Jaskowski  
*Warsaw University of Technology, Poland*

The article presents the prototype of the original telemetric system developed as a part of Warsaw University of Technology Rector's Grant by Science Club of Electrical Engineering in Transport Systems (KNEST) together with the Faculty of Transport. The system was designed for remote monitoring and recording of electric vehicle's operating parameters. Under the project electric go-kart was a technology demonstrator for which velocity, current, voltage, temperature and GPS coordinates were recorded. Data are transferred in real-time, what allows to monitor all parameters of the electric vehicle on-line. The article describes functional requirements for the developed system and the elements used, including sensors of signals. The authors present steps of transfer of data acquired from the vehicle until their visualization at the remote computer through the developed application. The advantages of the system are long range wireless connectivity, low price and wide upgrade possibilities. The tests performed have shown the correct functioning of the system and its compliance with the assumptions.

**Keywords:** telemetry, electric vehicle, go-kart.

## 1. INTRODUCTION

Electric vehicles are currently the smallest group of cars in Poland [1]. The electric and electronic devices applied in them allow them to cover small distances, most often in city traffic. There is still the limit of battery – energy tray, that capacity of which defines the range of vehicle. This crucial parameter is affected by a number of other factors such as driver's behaviour, topography and temperature of surroundings.

By telemetry we call the wide application of techniques such as remote measurement, sending and archiving measurements data [2]. The telemetric supervision over the parameters of vehicle is known from application in e.g.: car races or transport solutions for logistic applications [3]. It can be also applied to monitor the condition of electric vehicles.

The article presents the original solution of a telemetric system for electric vehicles, developed as part of Rector's Grant by Science Club of Electrical Engineering in Transport Systems (KNEST) at Warsaw University of Technology Faculty of Transport [4]. The demonstration of technology is an electric go-kart that is the effect

of the „Construction of an electric go-kart vehicle adapted for co-operation with outside control source” project development, finished as a part of the Big Pool for science projects of Student Council of the Warsaw University of Technology in 2014. Go-kart's description and its modification for adaptation to the requirements of the project were previously presented in the article [5].

## 2. FUNCTIONAL SYSTEM REQUIREMENTS

According to electric go-kart construction specification and operating parameters, the telemetric system should accomplish the following:

- measure parameters of go-kart movement in the real time,
- save received data into log file on a go-kart onboard computer,
- send received data via radio to a remote computer,
- visualize received data on a remote computer.

The registered data are: velocity and acceleration of the vehicle, GPS coordinates, temperature of selected parts (battery, engine, converter), battery voltage and current. The range of measured quantities is shown in Table 1.

Table 1. Registered parameters during movement of the vehicle.

Parameter	Unit	Minimum quantity	Maximum quantity
GPS coordinates	[geographical°'"]	N/A	N/A
Car velocity	$\left[\frac{km}{h}\right]$	0	90
Car acceleration	$\left[\frac{m}{s^2}\right]$	0	20
Battery current	[A]	0	150
Battery voltage	[V]	40	60
Temperatures of engine and converter	[°C]	20	160

### 3. ARCHITECTURE OF TELEMETRIC SYSTEM

Telemetric systems are made of: devices for data acquisition, devices ensuring communication between monitored object and remote supervisor and data presentation tools for users. The architecture of designed telemetric system is shown in Fig. 1.

platform for processing and converting it to a digital one. Communication with data sensors is realized via RS232C interface. The onboard computer is a small dimensions miniITX PC, which allows to mount it on the go-kart frame. The computer's function is integration of data received from sensors, their optimization and sending them to the radio transmitter.

Data transmission is realized via radio using industrial modems working at 464 MHz frequency. Amongst the wireless communication interfaces, industrial radio modems can send stable and reliable broadcast signal up to 7km. Data encryption ensures safe transfer. The flaw of this solution is lack of control over integrity of transferred data, and because of that not all packages might be received. That is why the communication control algorithm takes that into account, and data from particular sensors are broadcasted in separate packages. If the software on the receiver side cannot read the package, it is ignored. Data are passed to radio-modem via RS232C interface.

The alternative solution might be the use of the Wi-Fi network, but in the field conditions (for example: race) it might be not stable enough because of high amount of networks operating on the same frequency. Nonetheless, the telemetric system is equipped with IEEE 802.11 interface, which allows to use wireless networks as a means

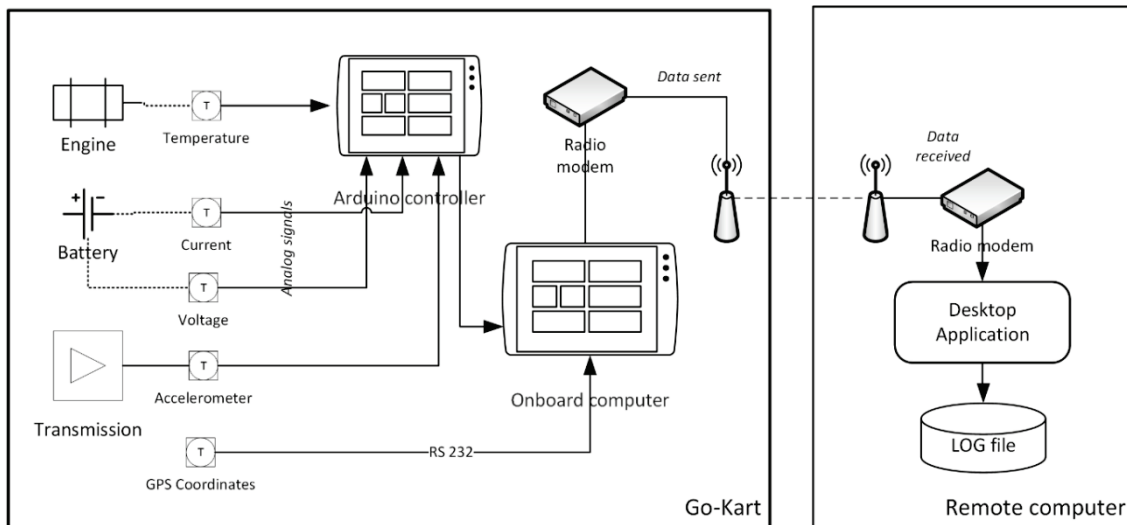

Fig. 1. Telemetric system architecture.

The role of the onboard computer is reading the measurements data from the installed sensors, their transformation, validation and integration into packages ready-to-send to the remote computer. Because most sensors have analogue output signal, we designed a control unit based on Arduino™

of data transmission. The TCP/IP protocol is used during data transfer via Wi-Fi network and client-server communication technology.

Remote computer is used to visualize received and registered data in a graphic form. Visualization is rendered by proprietary software

working in Windows environment. Data from radio-modem are received via RS232C port and displayed in a graphic form. The possibility of data storage for later analysis is also provided.

#### 4. MEASURING SYSTEM

Signals are measured by the following sensors: inertial Razor IMU measuring acceleration, magnetic field and angular velocity of vehicle, electric Hass 200-S and GPS receiver Venus Logger (Fig. 2). Vehicle's velocity is measured by Hall-effect velocity sensor. Battery voltage is read with the help of Arduino platform calibrated voltage converter.

a)

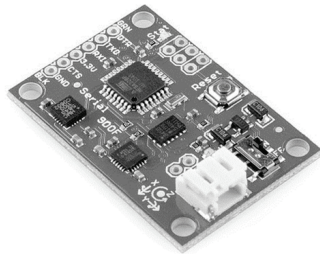

b)

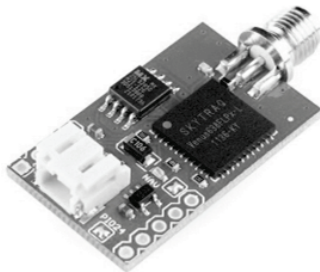

c)



d)

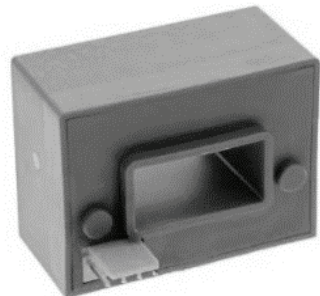

Fig. 2. Measurement sensors Razor IMU (a), GPS Venus Logger (b), Hass 200-S (c), Hall-effect (d).

Measuring control unit was developed using the Arduino™ platform software [6]. This platform stands out due to its quite advanced possibilities, and on the other hand low energy demand and a compact form. Also important are common availability of components and relatively low prices compared to the existing professional solutions. Our solution implements programming platform Arduino Mega 2560 with 8 KB of operating memory, 16 analogue inputs and 256 KB of Flash memory. Arduino platform communicates with the on-board computer via RS232C interface and is placed in the same casing.

The measuring system installed on the electric vehicle consists of the ITX minicomputer, a measuring control unit based on Arduino, a micro-controller and a radio-modem. Whole of that is put inside aluminium casing (Fig. 3), that is equipped with connectors to connect outside source of signals.

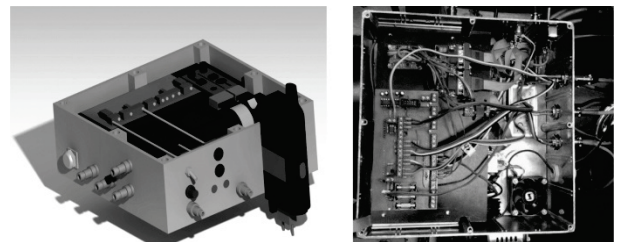

Fig. 3. System design (left) and view inside measuring system (right).

The measuring system casing is mounted on a go-kart back frame, on a specially designed support (Fig. 4).

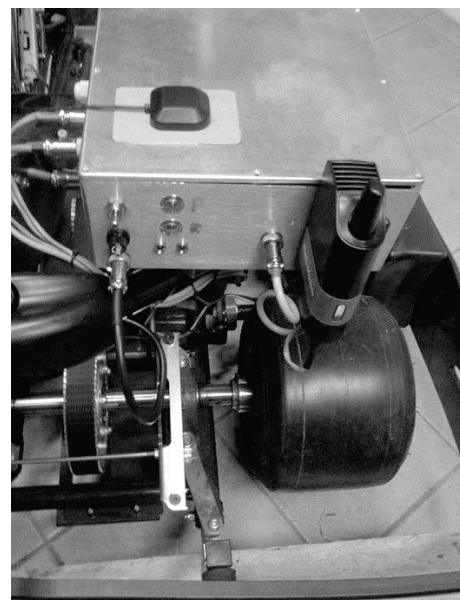

Fig. 4. Casing location on a go-kart back frame.

### 5. THE SOFTWARE

According to the concept developed at the system design stage, the software was made of the following independent components (Fig. 5):

- application controlling Arduino micro-controller – low level data read from sensors placed on go-kart and preliminary treatment,
- application *KnestConsoleServer* – data read from the Arduino control unit, their consolidation and transfer to remote computer via radio-modem,
- application *KnestTeleViewer* – visualization of data received from the modem and their storage.

Measuring control unit program was written in C programming language with the use of the integrated Arduino IDE environment. Particular data reads from sensors were designed as separate procedures. *Loop* is used from the moment the micro-controller is turned on until it is turned off.

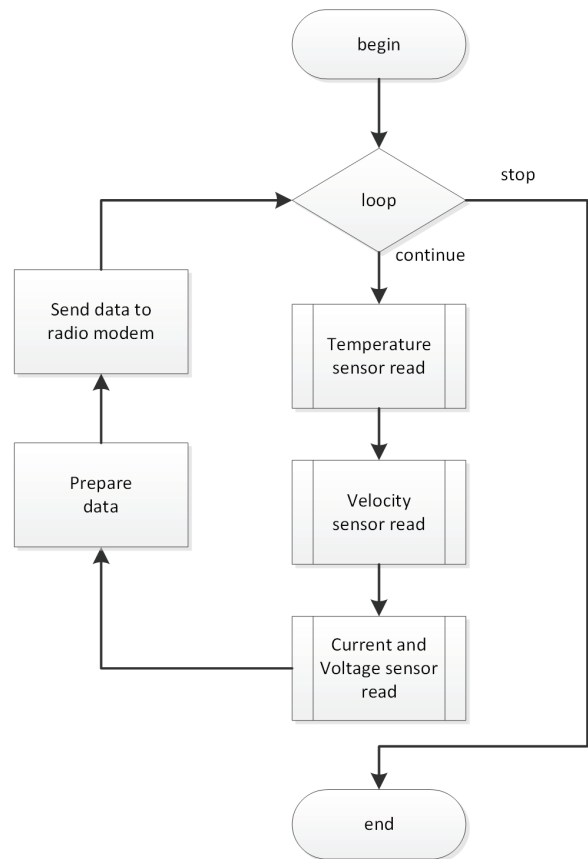

Fig. 6. The algorithm of reading data from go-kart sensors.

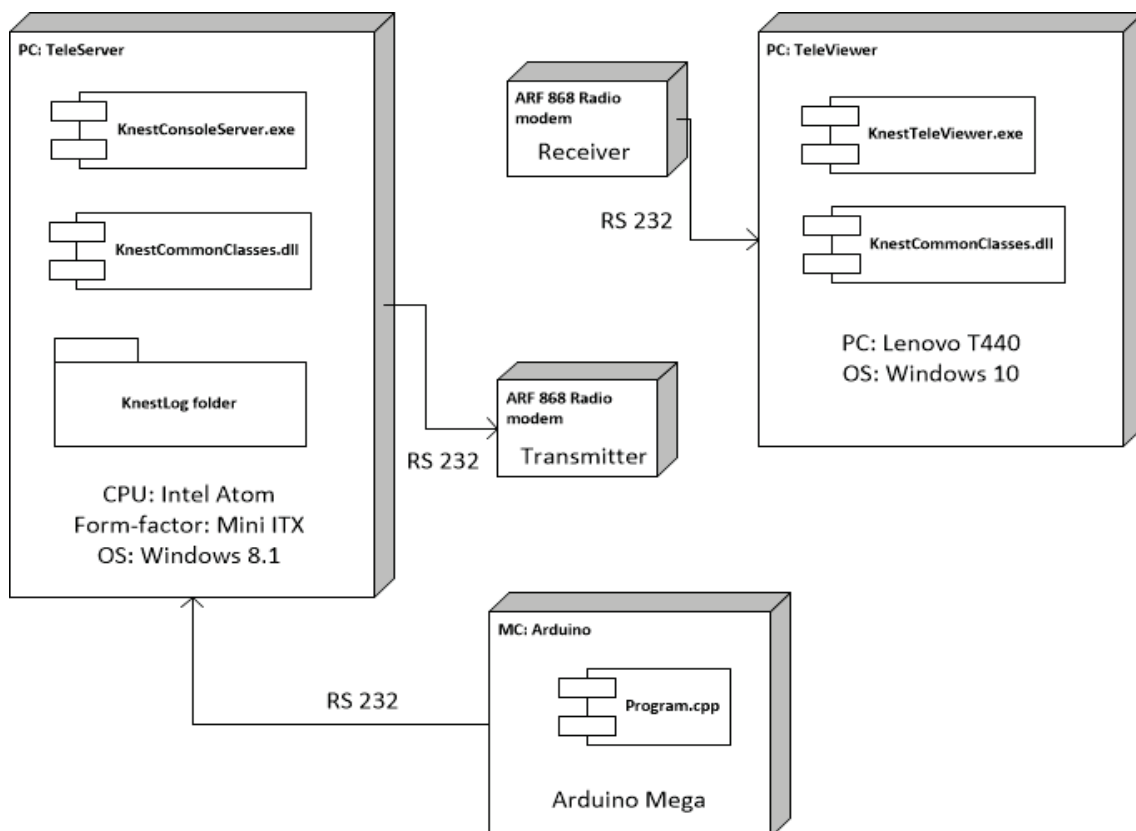

Fig. 5. Diagram of system software components.

The program *KnestConsoleServer* runs on a go-kart onboard computer. After turning it on, it periodically reads data from the measuring control unit, preliminary converts and sends them to the radio-modem (Fig.6). The program configuration is loaded from the configuration file. It allows for easy configuration of COM ports and other parameters without any program code modification. All data sent to modem are stored in a log file in a plain text format. It allows for later analysis of the stored data and makes it easier to find possible communication problems with the remote computer.

The program *KnestTeleViewer* reads telemetric data from the radio-modem and shows it in a graphic form (Fig. 7). Application was designed with the use of the *WinForms* technology on Microsoft .Net 4.0 platform and works on Windows 7/8/10 Operating Systems [7]. To demonstrate the operating application without being connected to the radio-modem or in a situation that data is not available, the demonstrating mode was developed. Switching program into radio-modem data read mode is made by selecting a proper option on a control panel. The program allows for registered data visualization and saved in LOG file via *KnestConsoleServer* program.

Both the programs *KnestConsoleServer* and *KnestTeleViewer* use a common class library

*KnestCommonClasses* (Fig. 8). Abstract class *ComReader* implement a common functionality to read data from the COM port. Class *Pomiar* is a container for storing the current measurement data. Class *PomiarController* implements asynchronous reading of data from the various COM ports. Next, measurements data are sent to an output COM port in order to send them through a radio modem.

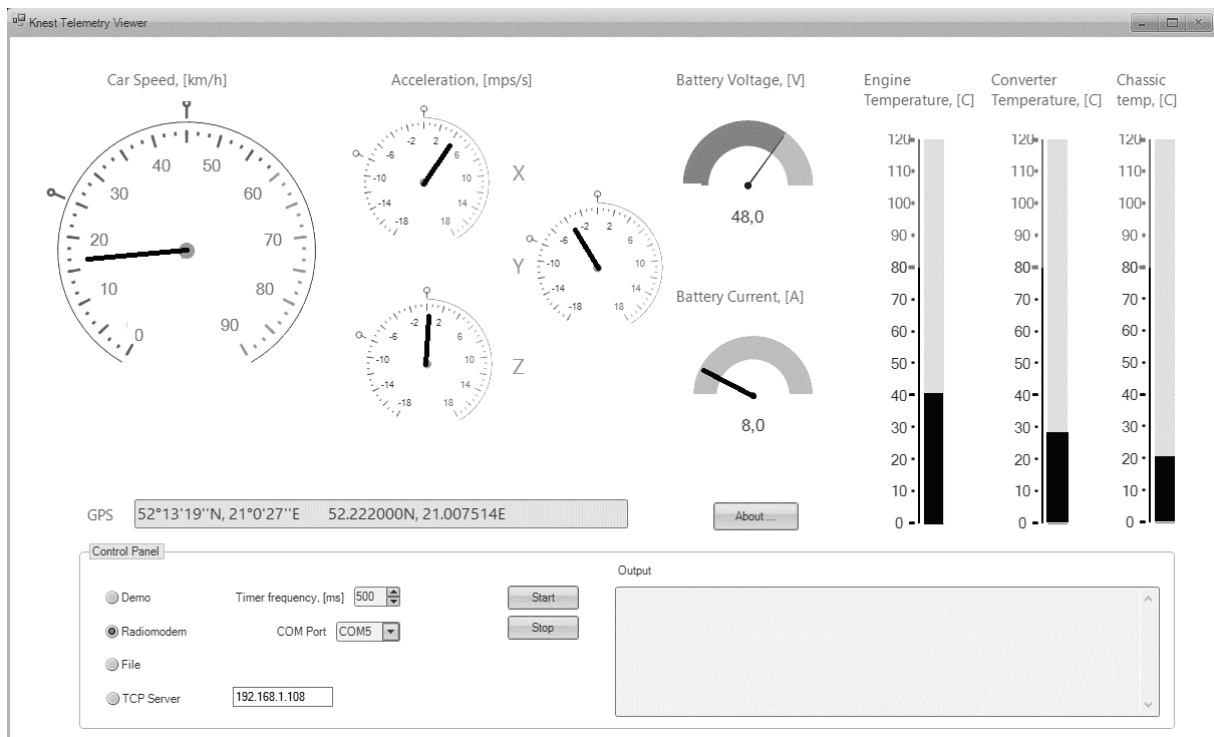

Fig. 7. Telemetric data visualization.

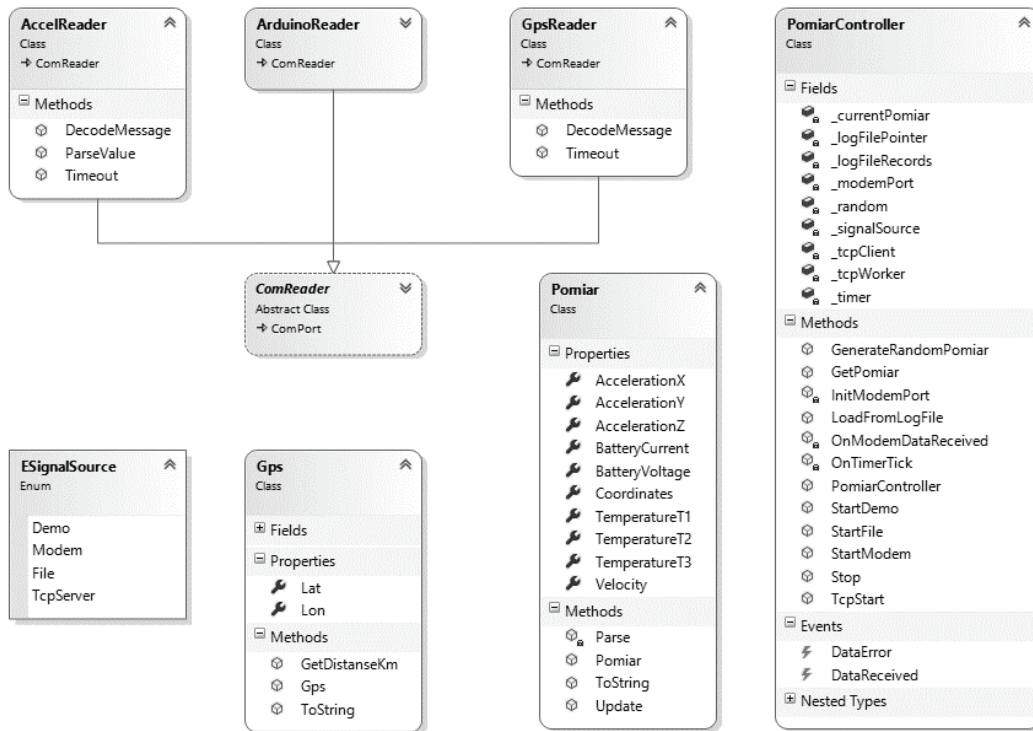

Fig. 8. Application common classes diagram.

### 6. SYSTEM TESTING

To acquire measurements data, we conducted go-kart test rides on Warsaw University of Technology campus. During the rides we registered data reads from particular sensors, while the vehicle was in motion and while it was still. The onboard computer was configured with the use of the wireless network. Next, we checked if all sensors operate properly and if read data are transferred to application. After this, the controlling application was switched to the radio-modem transmission. We observed that within the WUT campus the signal strength of the radio-modem was good, and number of errors within

data sent to the remote computer during 20 minutes time was 4 records, from which 2 were concerning engine temperature and the other two – vertical acceleration.

The terrain rides took an hour. The environment temperature was 6 degrees Celsius, with dry asphalt surface. During the rides, sensor reads were saved to the log file. After the test ride had finished, records were loaded to MS Excel and subjected to preliminary verification if registered values are in acceptable ranges. After the removal of misreads, based on the selected part of the run the charts showing particular reads of registered signals during the ride were made (Fig. 9-11).

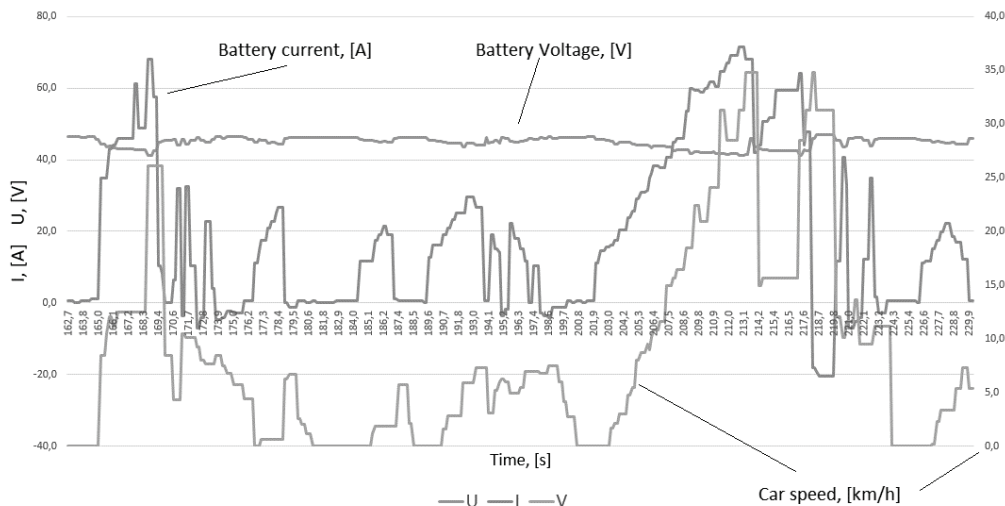

Fig. 9. Battery current I(t), voltage U(t) and car speed V(t) measurements.

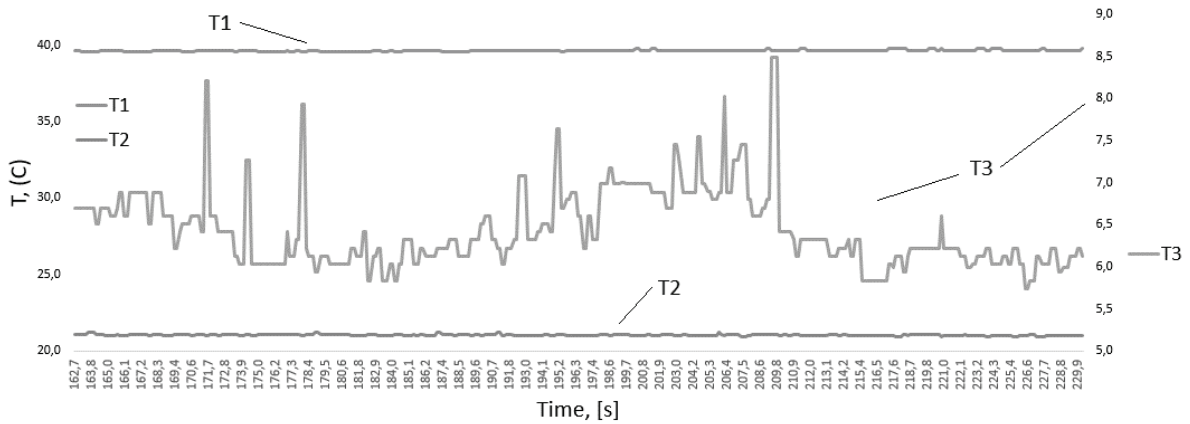

Fig. 10. Temperature of go-kart's engine T1(t), converter T2(t) and chassis T3(t).

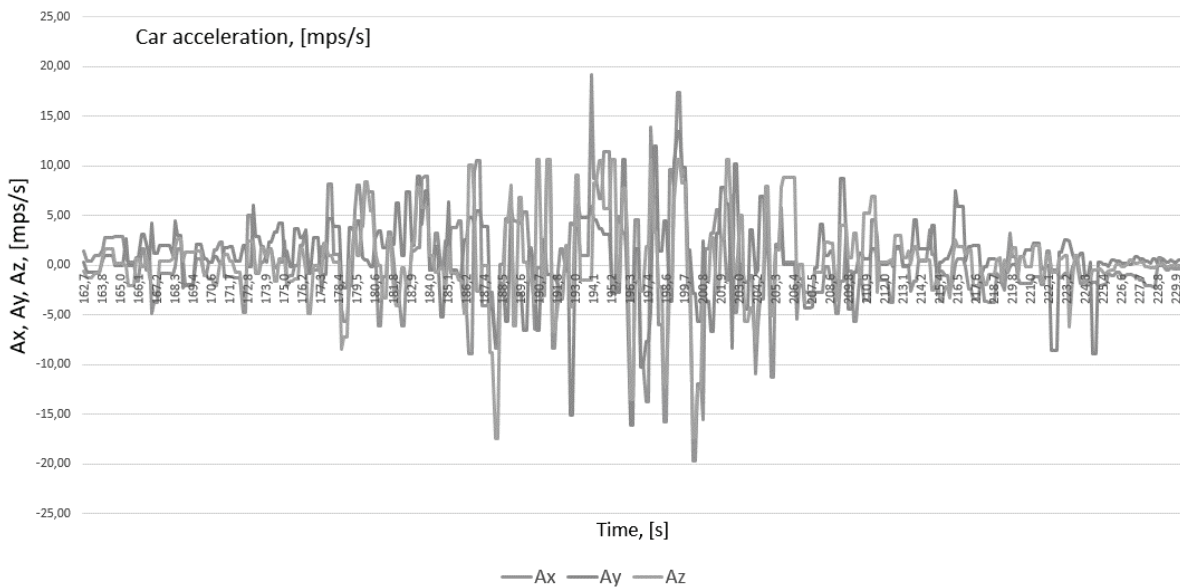

Fig. 11. Car acceleration in three dimensions Ax(t), Ay(t), Az(t).

Based on preliminary analysis of the measurement data we can tell that significant increase in engine's current is directly connected to vehicle's acceleration and decreases battery voltage. The temperature of the engine is changing in small range, it is related to efficient of natural cooling and low temperature of the surroundings. During longer observations the decrease of battery voltage from 48V to 42V was observed.

### 7. CONCLUSIONS

The aim of our project was to develop a telemetric system consisting of computer systems with appropriate software for electronic measurements, registration, broadcasting. The system should allow the presentation of the selected electric vehicle motion parameters: velocity, acceleration, GPS coordinates, battery

current and voltage, the temperature of the selected components.

The concept of a system consisting of measurement system, onboard computer put in electric vehicle, radio-modems transferring telemetric data remotely and software visualizing results was proposed. Next, the idea of system scheme was developed. We made the measurement control unit board using Arduino micro-controller platform. Next, we built the computer based on the miniITX platform. The measurement control unit was programmed to read and convert input data according to accepted units of measure.

The program for the measurement control unit was written in the C programming language, and next saved in the micro-controller's memory. The onboard computer application controls and integrates data reads from sensors, consolidates them into packages, and sends to remote computer

using the radio-modem. C# language and .NET platform were used during programming. The program with GUI was developed, and it allows to monitor current values of all parameters read from the radio-modem. The project of the onboard computer was developed, based on standard aluminium casing, adapted to the project specifics. The onboard computer was mounted on the electric go-kart chassis and connected to the sensors and the power supply system. We tested the system in the laboratory environment, as well as in real conditions. During testing the correct operation of the system was confirmed.

The designed system is a complete independent solution, that in future can be used to monitor movement parameters of most of already existing or prototype electric vehicles. The advantages of our system are long range wireless connectivity, low price and ease of upgrade. The finished project can be the basis for further research in multidimensional analysis of recorded data and adaptation of device for measuring needs of multiple categories of electric vehicles, including electric vehicle for disabled people, built at Faculty of Transport of Warsaw University of Technology [8].

## REFERENCES

- [1] Moćko, W., Wojciechowski, A., Ornowski, M.: Prospects of the electric cars market development in the forthcoming years. Motor Transport, 2011
- [2] Fryśkowski B., Grzejszczyk E.: Data transmission systems, Transport and Communication Publishers, Warsaw 2010.
- [3] Barański, Marcin, Decner A., Jarek T., Polak A.: Diagnostic and monitoring of traction electrical machines using the standalone and telemetric, multichannel data acquisition system. Logistics No 3/2015, pp. 156-165
- [4] KNEST Student Science Club (<http://www.knest.pw.edu.pl/>)
- [5] Koniak M., Czerepicki A., Jaskowski P., Wiśniewski S, Wytrykowska A.: Electric vehicle modifications to allow the external wireless control, for example of electric go-kart, in: Logistics No 4/2015, pp. 467 - 474
- [6] Margolis M.: Arduino Cookbook, O'Reilly Media, Inc. 2011.
- [7] C. Nagel, B. Evjen, J. Glynn, K. Watson, M. Skinner. Professional C# 4.0 and .NET 4. Wrox, 2010
- [8] "ECO-Mobility" Project Implemented Under European Union Operation Programme Innovative Economy ([http://www.eco-mobilnosc.pw.edu.pl/en\\_personal-rapid-transit,14.html](http://www.eco-mobilnosc.pw.edu.pl/en_personal-rapid-transit,14.html), last access: 2016-11-15)

Date submitted: 2016-11-20

Date accepted for publishing: 2017-02-17

---

**Piotr Tomczuk**  
Warsaw University of Technology, Poland  
[ptomczuk@wt.pw.edu.pl](mailto:ptomczuk@wt.pw.edu.pl)

**Andrzej Czerepicki**  
Warsaw University of Technology, Poland  
[a.czerepicki@wt.pw.edu.pl](mailto:a.czerepicki@wt.pw.edu.pl)

**Marcin Koniak**  
Warsaw University of Technology, Poland  
[koniakm@wt.pw.edu.pl](mailto:koniakm@wt.pw.edu.pl)

**Piotr Jaskowski**  
Warsaw University of Technology, Poland  
[piotr.jaskowski0@gmail.com](mailto:piotr.jaskowski0@gmail.com)