

Logistics Engineering to Improve the Productivity Indicators

Edward Michłowicz, Katarzyna Smolińska, Bożena Zwolińska
AGH University of Science and Technology, Krakow, Poland

In the systemic approach, a production company is a complex system of objects and relations between the objects, as well as between the system and its surroundings. The large number of variables and company performance assessment indicators result in the constant search for the methods of formalising the mutual dependencies. The discipline which, through the integration of multiple processes, enables the discovery of practical solutions is logistics engineering. In Poland, the term is not very common, while in the USA (for example), logistics engineering – taking advantage of mathematical methods and cutting edge science, is a widely used tool supporting the everyday business activities of companies. The article describes primary tasks of logistics engineering in relation to production companies. Furthermore, original algorithms for the improvements of company productivity are presented.

Keywords: productivity, engineering, company performance.

1. INTRODUCTION

The term: *logistics engineering* in Poland seems hardly known at all – definitely, it is not very commonly used. The popularisation of the term is worth considering, especially when systemic actions in multiple areas (e.g. production and logistics) are planned in order to improve the productivity of the company. Even more so, considering that the understanding of the term: *engineering* is currently becoming much wider than its traditional definition. Until now, the term *engineering* has been accepted to mean the activity involving the design, construction, modification and maintenance of cost-effective solutions for practical problems, using scientific and technological knowledge. The New Universal Encyclopaedia [1] provides the most general definition of engineering as: “*technological work resulting in an object (prototype), production method (technology) or change in the environment*”. Therefore, linking *engineering* with creative activity resulted in the creation of terms, such as: environmental engineering, mechanical engineering, materials engineering, surface engineering and many others. Scientific progress results in the widening of the areas covered by the

term *engineering*. For example, previously unheard of terms, such as: biomedical engineering, genetic engineering or sociology engineering has become more and more popular. Generally, it can be said that the engineering of any discipline involves the practical application of mathematics and other sciences in the technical production of this discipline.

In the United States of America, the term logistics engineering is commonly used. There is also an organisation (structurally similar to CSCMPs) – The Council of Logistics Engineering Professionals (CLEP). Interestingly – many renowned universities offer programmes with the same name (e.g. NCSU [2] Course Catalogue, 2015). According to the Council of Logistics Engineering Professionals [3]:

“*Logistics Engineering*: The professional engineering discipline responsible for the integration of support considerations in the design and development; test and evaluation; production and/or construction; operation; maintenance; and the ultimate disposal/recycling of systems and equipment. Additionally, this discipline defines and influences the supporting infrastructure for these systems and equipment (i.e. maintenance, personnel, facilities, support equipment, spares,

supply chains, and supporting information/data). The practice of logistics engineering is exercised throughout the system life-cycle by conducting the iterative process of supportability analysis and the accomplishment of trade-off studies to optimize costs and system, logistics, and performance requirements.”

In *Logistics Engineering Handbook* G. Taylor [4] wrote: “The fact is, there are few, if any, significant differences between business logistics and engineering logistics except that logistics engineers are often charged with handling the more “mathematical” or “scientific” application in logistics. An objective and challenge for the future is to address logistics in much broader context, reflecting a total system approach.”

2. THE ROLE OF LOGISTICS ENGINEERING

The role of logistics engineering in a production company is the development and preparation of a system of activities which, by the application of the rules and laws of logistics as well as other scientific disciplines, enable the performance of logistic tasks supporting the achievement of the effects specified in the strategy for the company. The primary strategies include:

- high customer service quality,
- World Manufacturing Class,
- achievement of the desired (specified) performance,
- achievement of the specified economic and technical indicators.

The production system can be variously defined. Using the simplest definition of the system *in terms of the theory of systems* it can be stated that the production system (functional, technological) is a structured set of elements and relationships between them [5]:

$$SP = \langle E, R \rangle \tag{1}$$

By introducing specific elements into such definition, a more developed form of the system is obtained:

$$SP = \langle \{ X, Y, T, Z \}, R \rangle \tag{2}$$

$$T: X \rightarrow Y \tag{3}$$

where:

$X = \{X_1, X_2, \dots, X_i, \dots, X_M\}$; for $i = 1, \dots, M$ – set of external magnitudes describing the input elements (materials and parts, equipment, personnel, information, capital, energy),

$Y = \{Y_1, Y_2, \dots, Y_j, \dots, Y_N\}$; for $j = 1, \dots, N$ – a set of external magnitudes describing output ,

$T = \{T_1, T_2, \dots, T_n, \dots, T_S\}$; for $n = 1, \dots, S$ – set of external magnitudes describing the elements of the processing process of the input vector into the output process (technological, transportation, storage, control, service operations),

$Z = \{Z_1, Z_2, \dots, Z_o, \dots, Z_U\}$; for $o = 1, \dots, U$ – set of the external magnitudes describing the management process (planning, organization, control, monitoring),

$R = (R_X \times R_Y \times R_T \times R_Z)$ – material, information feedback (relationships) between elements (X, Y, T, Z) of the SP system.

The elements of the input and output of the production system that are most often adopted in a market economy are:

Input elements X:

1. X_1 – work-related objects (materials and raw materials, semi-finished products, parts, components),
2. X_2 – the technical means of production (engineering equipment, plant and equipment),
3. X_3 – the human factor (engineering and technological, executive, managerial personnel),
4. X_4 – information (forecasts and market information, information on product design and utility functions),
5. X_5 – capital (capital invested in the technical means of production, materials, semi-finished and finished products, financial capital in banks, capital left in clients’ accounts).

Output elements Y:

1. Y_1 – finished products according to the production assortment offered,
2. Y_2 – production services,
3. Y_3 – production waste, discarded products and secondary raw materials for third parties,
4. Y_4 – information (relating to product quality, cost, state of the manufacturing process).

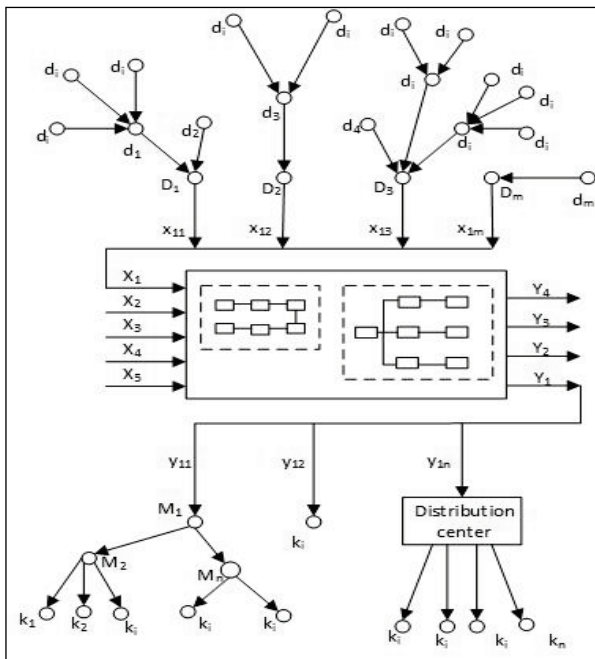

Fig. 1 shows the general form of the production system, indicating sample elements and interrelationships.

The logistic tools and methods useful in the logistics of the company are generally known [6], [7], [8]. Their application depends (besides the adopted strategy) on the abilities, knowledge and skills of the technical and management staff as well as the assumed scope of activities. Table 1 shows a list of basic tasks necessary for the improvement of the functioning of the production system.

The selection of the area and methods for task implementation is the first, crucial phase of the activities aimed at achieving the desired goals. The second stage of the activities aimed at the improvement of the effectiveness of a production

company should involve the development of an appropriate process algorithm. The process which involves the largest share of capital and is crucial to the potential success of any production company is manufacturing. Manufacturing moves the main flow of materials through the production departments of the company. This flow depends on multiple factors – the structure of the production system definitely has the largest impact on the flow processes. It seems obvious that, from the logistic perspective, the appropriate control of the material flows in the production system should be one of the chief logistic processes. “Appropriate control” should mean the method of control which guarantees the continuity of production processes in accordance with the 7R logistics principles and 9 LPL production logistics principles [9].

In the Table 2 shows the nine laws of production logistics (9 LPL).

Assumption in planning implementation processes: there is constant monitoring of the effects of company business and key performance indicators are specified for the production area (performance, effectiveness, productivity).

During the selection of methods enabling the improvement of the effectiveness indicators, two groups of methods are available:

- non-logistic methods (according to Taylor [4] they include mainly: Management Science (MS), Operations Research (OR) and Artificial Intelligence (AI),
- logistic methods (Lean – enterprise, production techniques, production logistics principles [9], [10].

Table 1. Basic tasks to be implemented in the production system.

Basic tasks				
- supply strategy (choice of suppliers)	- demand for warehouse space	- manufacturing strategy (continuous material flow)	- storage area	- distribution strategy
- classification of components (ABC, XYZ, Pareto)	- admissions technology (including identification)	- Basic Laws of Production Logistics (9 LPL)	- stocks analysis	- picking
- forecasting	- stocks model	- WIP	- storage technology	- customer service models
	- location (ABC)	- lean toolbox (VSM, TPM)		- reverse logistics
	- means of transport	- IIS (MRP, ERP)		- optimization (VRP)
Computer assistance - common hardware and software platform				
Indicators of efficiency evaluation				

Table 2. Laws of production Logistics LPL.

Number of law	Law
The first law: 1_LPL	In the long term, the entry levels of the materials entering the position and leaving the position must be balanced.
The second law: 2_LPL	The time of transition of material through the position depends on the rate of the work in progress (WIP) to the rate of output from the process.
The third law: 3_LPL	Reducing the utilization of a position enables a disproportionate reduction in WIP jobs and shortens the transit time of material through this position.
The fourth law: 4_LPL	Variance and average value of the labour intensity of the task define the logistic potential of position.
The fifth law: 5_LPL	The size of the work in progress (WIP) buffer required to ensure the proper utilization of the position depends chiefly on the flexibility of the load and efficiency of the position.
The sixth law: 6_LPL	If orders are fulfilled according to FIFO principles, the time between operations does not depend on the labour intensity of individual operations.
The seventh law: 7_LPL	Applying sequential rules can significantly affect the average transit time only at a high level of work in progress and a wide range of distribution of labour intensity of tasks.
The eighth law: 8_LPL	Variance in transit time depends on the sequential rules applied, the level of work in progress and distribution of the labour intensity of the tasks.
The ninth law: 9_LPL	Reliability of the logistics process is determined by the mean value and distribution of time of material transit through the system.

Currently, the key to understanding the operations of a company is the awareness, that it functions as a part of a larger system. The development of the SCM concept forces the companies to transform from functionally-oriented to process-oriented organisations. The common element, shared by different approaches to logistics are material flows and their skilful management. Therefore, the means to achieve this goal should be flow control methods. In relation to supply chains, Nyhuis and Wiendhal [9] said directly that: *The fundamental goal of production logistics can thus be formulated as the pursuance of greater delivery capability and reliability with the lowest possible logistic and production cost.*

Now, the integration of production planning and logistics becomes popular in many companies [11]. The algorithm enabling the analytical consideration of material flow processes in a

production company will be presented below. The flow of materials through the equipment and warehouses (buffers) can be formulated as follows (according to Tab. 3 and Figs. 2, 3, 4).

If the values describing logistics processes are (Tab. 3):

Table 3. Process-describing values designation.

Value designation	Value description
$i, j = 1, 2, \dots, n$	consecutive numbers of production equipment UP, i.e. ($i \in UP, j \in UP$)
$k = 1, 2, \dots, p$	batch number of the material MT flowing between the equipment, ($k \in MT$)
$s = 1, 2, \dots, st$	consecutive numbers of transport equipment UT, ($s \in UT$)
$m = 1, 2, \dots, ma$	warehouse number MA, ($m \in MA$)
$M_{ij}^w(k)$	shipment moment of the k batch of material from point i to point j
$M_{ij}^d(k)$	delivery moment of the k batch of material from point i to point j
$t_{ij}^s(k)$	total time of transport cycles (loading, transport, unloading, return) of the k batch of materials, with transport means s from point i to point j
$\Delta t_{ij}^m(k)$	time spent by the k batch of material at warehouse m , between points i and j
$t_j(k)$	time of the k batch of material crossing the point j (time of k batch service on equipment j)
$t_{pj}^{(a)}$	time of conversion of the j equipment for the production of (a) products

then:

- the delivery moment of the k batch of material from point i to point j is given by the formula:

$$M_{ij}^d(k) = M_{ij}^w(k) + t_{ij}^s(k) + \Delta t_{ij}^m(k) \quad (4)$$

- shipment moment of the k batch of material from point i to point j :

$$M_{ij}^w(k) = M_{i-1,j}^d(k) + t_i(k) \quad (5)$$

- shipment moment of the k batch of material from point j to point l :

$$M_{j,l}^w(k) = M_{j,l}^d(k) + t_j(k) \quad (6)$$

however, two cases should be taken into consideration:

- if:

$$M_{ij}^d(k) < M_{j,l}^w(k-1); \text{ (case 1)} \quad (7)$$

the moment of delivery of the k batch of material to the j production equipment is earlier (before) than the moment of shipping the previous $(k - 1)$ batch of material from the j production equipment to the l equipment, the material before the j equipment is stored for the period of $\Delta t_{ij}^m(k)$;

– if:

$$M_{ij}^d(k) > M_{j,l}^w(k-1); \text{ (case 2)} \quad (8)$$

the moment of delivery of the k batch of material to the j production equipment is later (after) than the moment of shipping the previous $(k - 1)$ batch of material from the j production equipment to the l equipment, the j equipment awaits (is in “downtime”) for the period of $\Delta t_j(k)$.

The flow of materials through the equipment and warehouses (buffers) can be formulated as follows (Figs. 2, 3, 4). Figures 2, 3 and 4 contain a graphical representation of the flows.

Material flows description:

- for UP production equipment
- for transport equipment
 - a) material transport to the UP production equipment through a buffer
 - b) transportation of the material between UP units without storage

In practice, professional computer software is more commonly used than analytical deliberations. The authors of this study, for example, use the Witness Process Optimizer (version 13) simulator which enables dynamic modelling, simulation and streamlining of business processes in a production company (production, stock, effectiveness, productivity, process balancing).

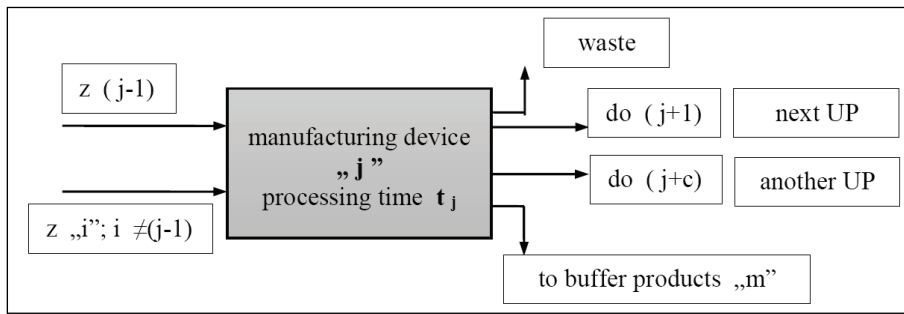

Fig. 2. Diagram of material flow through the UP production equipment.

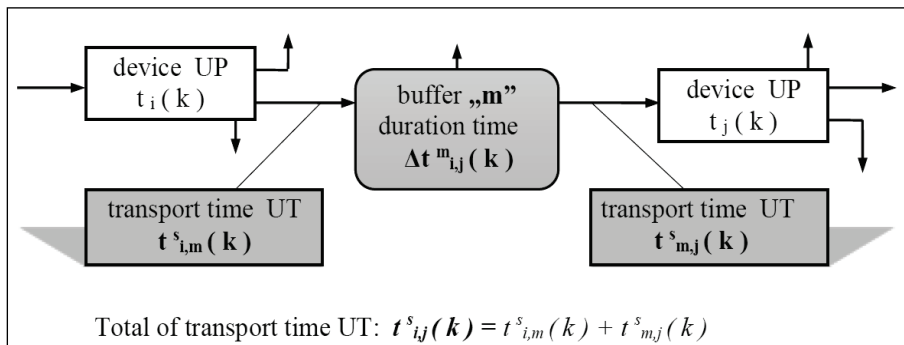

Fig. 3. Diagram of material flow through the buffer.

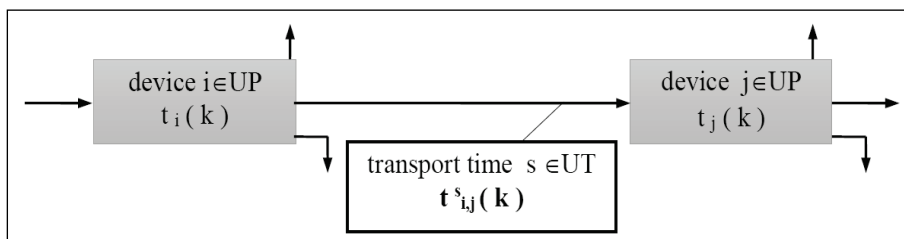

Fig. 4. Diagram of material flow between the UP production equipment units.

3. FLOW ALGORITHMS

The task of improving flow continuity can be implemented in several phases:

Phase I – Process identification.

Phase II – Selection of improvement methods and tools.

Further phases depend on the selection of methods providing the desired improvement of effectiveness. For production companies with broad product portfolios and frequent conversions, it becomes necessary to develop at least two additional algorithms:

- for the SMED (Single Minute Exchange of Die) method in order to reduction the conversion time,
- for the Kanban control system (for selected processes and assortments).

The first stage requires a very accurate identification of all processes related to production and logistics.

Stage I – Process identification – should include the tasks:

1. Selection of process for analysis.
2. Making a detailed diagram of the technological process.
3. Collection of process data, such as: orders, deliveries, stock, etc.
4. Designation of the primary parameters and values describing the process, providing the required time study for the durations of operations.

Table. 4. Time study for a window frames fitting station – fragment.

Frame fitting (operators: 2)			
Station diagram	No	Action description	Time [s]
<p>M – frames storage, K – computer, 1 – templates station, 2 – rack with fittings, L – assembly line</p>	Operator 1		
	1	Approaching the frames	2
	2	Frame collection	3
	3	Frame placement on the assembly line	3
	4	Number scanning	3
	5	Frame stamping	3
	6	Picking up the knife	2
	7	Cutting foil on the edges	20
	8	Laying down the knife	2
	9	Fittings collection	6
	10	Template collection	6
	11	Fittings adjustment	50
	12	Picking up the drill-driver	2
	13	Screws collection	3
	14	Screwing in the fittings	50
15	Laying down the drill-driver	3	
<p>1 – holders station, 2 – rack with fittings, L – assembly line</p>	Operator 2		
	1	Moving the frame	2
	2	Transition to the station	3
	3	Picking up the holders	2
	4	Picking up the drill-driver	2
	5	Transition to frame	3
	6	Screwing in the holders	15
	7	Fittings collection	6
	8	Screwing in the fittings	25
	9	Hinges collection	10
	10	Screwing in the hinges	35
11	Pushing the frame to the next station	2	
Total time of operation [s]			263

The time study is a very important element of developing the value stream. It should not be treated solely as measuring the time of specific tasks and operations. A time study implemented at a station structure is frequently a source of information regarding the possibilities of changing the arrangement of elements forming the specific station.

An example of a good time study (fragment) which resulted in the proposition of changing the arrangement of objects is presented in Table 4.

Stage II – Selection of improvement methods and tools – should involve:

5. Description and analysis of losses and waste in the process (e.g. 7 muda, 6 big losses).
6. Selection of the right tool (VSM, TPM, SMED, Kanban).

In case of selecting the VSM (Value Stream Mapping) method, the algorithm is described by the consecutive phases: III, IV and V (Fig. 5).

Stage III – elaboration of the map of the existing state – actions: 7, 8, 9, 10

7. Development of icons for the process.
8. Preparation of a map of the existing state (readable and in an appropriate format).

9. Determination and collection of information about possible proposals for changes to the existing system.
10. Plotting the proposed changes on the value stream map.

Stage IV – introduction of changes – actions: 11, 12

11. Preparation of arrangements and deadlines for possible changes.
12. Introduction of changes.

Stage V – analysis of results and improvement – actions: 13, 14

13. Analysis of the effects after introducing the changes.
14. Insistent implementation of the principles of *kaizen!*

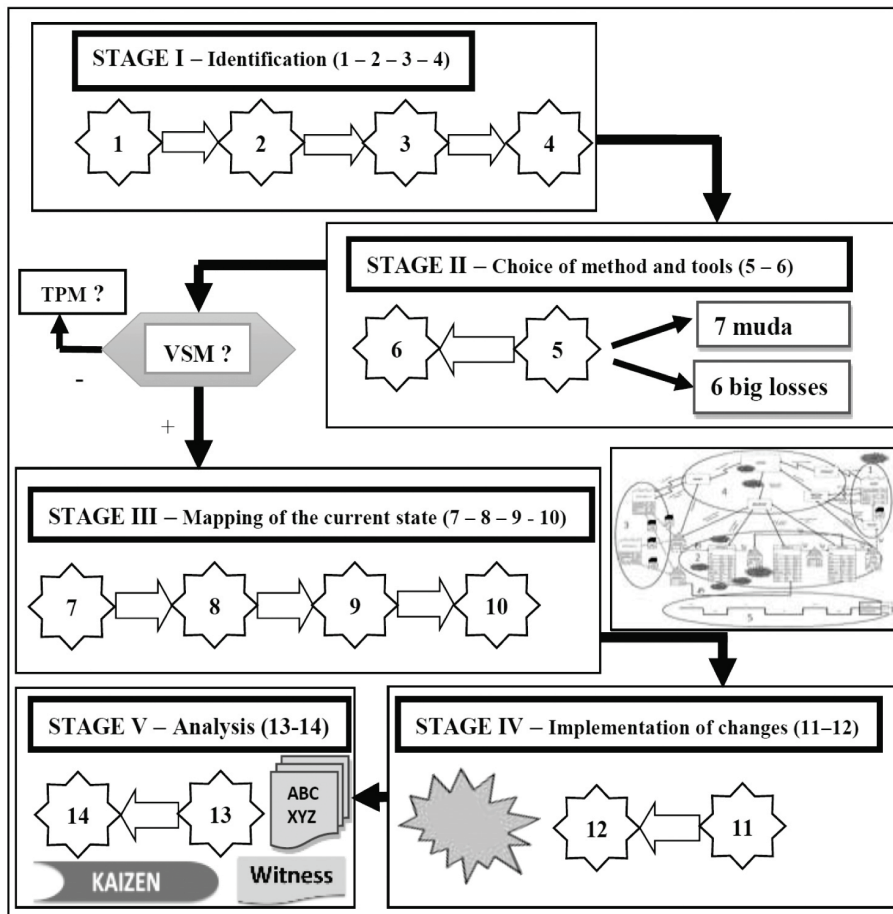

Fig. 5. Algorithm: improvement via the VSM method.

4. CONCLUSIONS

The broadly defined production management currently proposes many different methods and techniques for the improvement of the functioning of production systems.

Some of these methods have been developed within the framework of the Lean Enterprise (Production) concept. The systems related to the organisation and control of material flows, such as: 5S, 7 Muda, SMED, 5W+1H, JiT, Kanban and integrated IT systems, such as: MRP, ERP are commonly known.

The development of the strategies related to the supply chain and lean thinking involves going outside the scope of own company. This leads to a systemic approach towards production-related problems.

In order to streamline the processes related to material flows, it seems beneficial to additionally apply logistics engineering which integrates multiple business processes in a production company.

Without making any claims as to the importance of different methods of improving effectiveness, the old saying by J. Weber that “it doesn’t matter who does a thing, as long as it is done” is worth remembering.

REFERENCES

- [1] Nowa Encyklopedia Powszechna PWN, Wydawnictwo Naukowe PWN, Warszawa 2004.
- [2] www2.acs.ncsu.edu – North Carolina State University Course Catalog (v. 15.08.2015).
- [3] www.logisticsengineers.org – internet page CLEP (v. 20.08.2015).
- [4] Taylor G. D.: Logistics Engineering Handbook, CRC Press Taylor & Francis Group, Boca Raton 2008.
- [5] Michlowicz E.: Algorithms for improve efficiency in logistic production, LOGISTYKA, No 2/2015.
- [6] Bicheno J., Hollweg M.: The Lean Toolbox: The essential guide to Lean transformation, Piccie Books, Johannesburg 2008.
- [7] Michlowicz E: New challenges in production logistics. [in]: Fertsch M. (Eds.) Innovative and intelligent manufacturing systems, Publishing House of Poznan University of Technology, Poznan 2010, pp. 7-22.
- [8] Lödging H.: Handbook of Manufacturing Control. Fundamentals, Description, Configuration, Springer - Verlag, Berlin Heidelberg 2013.
- [9] Nyhuis P., Wiendhal H.P.: Fundamentals of Production Logistics. Theory, Tools and Applications, Springer – Verlag, Berlin Heidelberg 2009.

- [10] Michlowicz E., Smolińska K.: Research on the flow of material in production logistics, Research in Logistics & Production, No.1, 2015, pp. 21-31.
- [11] Kaczmarczyk W.: Wybrane modele planowania wielkości i szeregowania partii produkcyjnych, Wydawnictwa AGH, Kraków 2011.

Date submitted: 2015-10-18

Date accepted for publishing: 2016-05-31

Edward Michlowicz
AGH University of Science and Technology,
Krakow, Poland
michlowi@agh.edu.pl