



Science Arts & Métiers (SAM)

is an open access repository that collects the work of Arts et Métiers Institute of Technology researchers and makes it freely available over the web where possible.

This is an author-deposited version published in: <https://sam.ensam.eu>
Handle ID: <http://hdl.handle.net/10985/16815>

To cite this version :

Alexander GOUSKOV, Mikhail GUSKOV, Grigory PANOVKO, Alexander E. SHOKHIN, Maksat N. KALIMOLDAYEV, Zair Gakhipovich UALIYEV - Particularities of multi-cutter cutting dynamics - News of the National Academy of Sciences of the Republic of Kazakhstan, Series of Geology and Technical Sciences - Vol. Volume 3, Issue 435, p.Pages 231-239 - 2019

Any correspondence concerning this service should be sent to the repository

Administrator : archiveouverte@ensam.eu



**A. M. Gousov^{1,2}, M. A. Gousov³, G. Ya. Panovko^{1,2}, A. E. Shokhin¹,
M. N. Kalimoldayev⁴, Z. G. Ualiyev⁵**

¹Mechanical Engineering Research Institute of Russian Academy of Sciences, Moscow, Russia,

²Bauman Moscow State Technical University, Moscow, Russia,

³PIMM Laboratory UMR 8006, ENSAM, CNRS, CNAM, Paris, France,

⁴Institute of Information and Computational Technologies, Almaty, Kazakhstan,

⁵Abai Kazakh National Pedagogical University, Almaty, Kazakhstan.

E-mail: gpanovko@yandex.ru, shohinsn@mail.ru, gousov_am@mail.ru, mikhail.gousov@gmail.com,
mnk@ipic.kz, z.ualiyev@mail.ru

PARTICULARITIES OF MULTI-CUTTER CUTTING DYNAMICS

Abstract. Certain particularities of steady continuous cutting dynamics for multi-cutter turning and the results of mathematical modeling are discussed in the paper. The effect of processing parameters on the excitation of vibration in the case of multi-cutter turning of a long cylindrical part with finite flexibility is studied. Depending on the fixing rigidity of the cutters and their relative positioning, different forms of the tool oscillation and formed chips are analyzed.

The model is based on equations of motion and the cutting law in the form of a fractional function together with the equation for new surfaces formation which are represented as a system of differential-algebraic equations with several delays describing the dynamics of multi-cutter turning. These equations allow consider the regenerative mechanism of oscillations excitation in the system. The evolution of the cutter's oscillations to steady regime in the case of an angular shift of the cutters, as well as the evolution of chips are shown in the work. An example of the operation of cutters, which angular shift allows to control the work of the cutting edges is given. The reasons for the stability loss and the self-oscillations excitation are noticed. The procedure for integrating systems of differential-algebraic equations with retarded argument and the model of two-cutter turning taking into account the compliance of the cutting tool fixation is considered.

Influence of the technological system parameters on the stability of continuous cutting regime is analyzed.

Key words: multi-cutter turning, dynamics, modelling, continuous cutting, discontinuous cutting, self-excited vibration, stability, time-delay.

Introduction. The turning of parts is often accompanied by the occurrence of self-oscillations in the "machine-tool-workpiece" system, which adversely affects the quality of the parts produced and the equipment wear. Various reasons for their occurrence, in particular, caused by the nonlinearity of cutting forces, compliance of the machine elements or the part itself, cutting tool fastening conditions, turning along the surface formed on the previous revolution of the part (or tool), thermomechanical effects in the cutting zone, and etc. are detailed in modern literature [1-10]. Under certain conditions, turning with constant thickness of the removed layer (chips) can become dynamically unstable. General questions of the onset of the oscillations during cutting have been discussed in numerous works [1, 11, 12].

One of the reasons for the stability loss and the self-oscillations excitation is the nonlinearities of both the cutting forces and the frictional forces (in particular, when the flank face of the cutter is rubbed), which depend on the cutting speed and the thickness of the layer to be removed and which lead to chips discontinuity [13-15]. Other reasons for stability loss are the regenerative chatter, i.e. time delay between two subsequent tools, the workpiece compliance, temperature effects, etc. [4, 16-19].

Problem formulation. At the same time, due to the development of various non-classical cutting schemes, in particular, using multiple cutters simultaneously, a number of new problems related to the

analysis of the dynamics of the multi-cutter cutting process arise [20-25]. Note that multi-cutter turning allows combining different types of processing (roughing and finishing), the cutting depth (the thickness of the layer to be removed) in one pass can be increased, the transverse components of cutting forces can be balanced (which is important especially for turning long parts), manufacturing time is significantly shortened [26, 27]. In a number of cases such a scheme of processing makes it possible not to use intermediate support elements with simultaneous increase in the cutting depth.

The aim of this paper is to determine the conditions for self-excitation of oscillations and to estimate the possibility of realizing a continuous (segmentation-free) cutting. For this purpose, the effect of processing parameters on the excitation of vibration in the case of multi-cutter turning of a long cylindrical part with finite flexibility is studied. In the case of multi-cutter turning, the axial (along the longitudinal axis of the workpiece) displacement (vibration) of the cutters has an important role in the appearance of extremely undesirable vibration regimes (the phenomenon of dynamic instability). Depending on the fixing rigidity of the cutters and their relative positioning, different forms of oscillation of the tool and formed chips may occur.

Mathematical model of the multi-cutter turning. Let us consider the workpiece as an absolutely rigid body of cylindrical shape with the machined surface of radius R and length l . The workpiece rotates around its longitudinal axis with constant angular velocity ω (figure 1,a). The processing is carried out simultaneously by n cutters located along the circumference of the workpiece at an angle $\varphi_j (j = \overline{1, n})$ to each other so that $\sum_{j=1}^n \varphi_j = 2\pi$. All the cutters are fixed to a single support moving along the workpiece longitudinal axis with constant velocity V (figure 1,b). Each j -th cutter is considered as a rigid body independently fixed in a separate toolholder with finite stiffness in axial direction. For the sake of clarity of the results obtained, we shall limit ourselves to considering only the longitudinal (along the axis of the workpiece) components of the cutting forces and displacements of the cutter.

Note that all the subsequent reasoning and mathematical calculations are also valid for the case of longitudinal feed of a workpiece and a rotating support.

Mathematical model of nonlinear dynamics of the process under consideration can be described by the system consisted of three groups of equations: equations of technological system motion, cutting law and equations of new surfaces formation [7, 9, 11, 15, 21, 23].

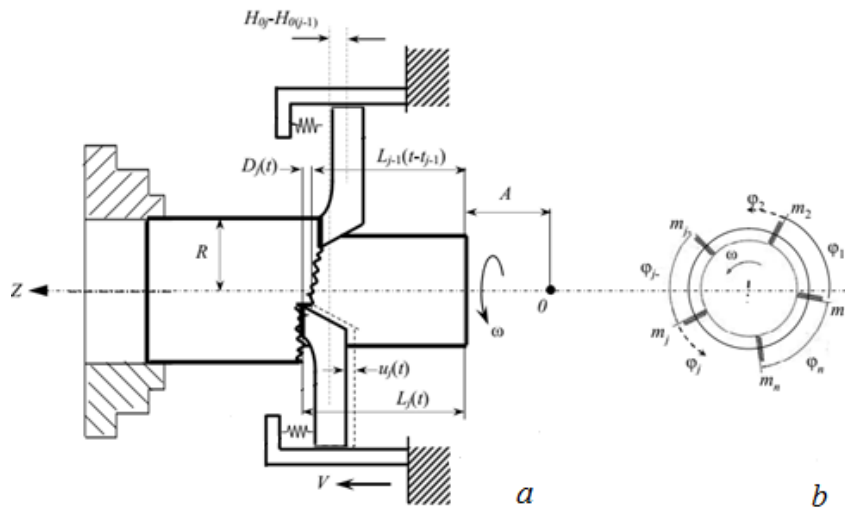

Figure 1 – Design scheme of multi-cutter turning

Equations of motion, describing vibration of the cutters in longitudinal direction could be written as follows [11-13, 15]:

$$m_j \ddot{u}_j = -d_j \dot{u}_j - k_j u_j + F_j(t, h_j); \quad j = \overline{1, n} \quad (1)$$

where m_j is mass of the j -th cutter, d_j and k_j are coefficients of damping and stiffness of the j -th cutter attachment, respectively; $u_j(t)$ is axial displacement of the j -th cutter relative to the nominal (quasistatic) state; $h_j(t)$ is cutting chips thickness removed by the j -th cutter.

Cutting law for every j -th cutter is described by the cutting law model in the form of a fractional function [7, 17, 20]:

$$F_j(t) = K_0 h_j(t) \frac{c + r h_j(t)}{c + h_j(t)}, \quad j = \overline{1, n} \quad (2)$$

where $K_0 = \gamma \sigma_L B$ is static cutting stiffness, σ_L is characteristic stress of the processed material; B is a width of the removed layer (chips); γ, r, c are experimentally determined coefficients. Thickness $h_j(t)$ of the material removed by the j -th cutter at multi-cutter cutting depends on the workpiece surface geometry, formed at cutting by the previous $(j-1)$ -th cutter.

New surfaces formation equations, forming by the j -th cutter, are the functions of time t measured from the free (untreated) end of the workpiece. Herewith the j -th cutter processes the surface formed by the previous $(j-1)$ -th cutter, at the moment $(t_j - t_{j-1})$. Time t_{j-1} is a delay, equal to the time of turning the part by the angle between the cutting edges $t_{j-1} = \varphi_{j-1}/\omega$. These features can be described by equations of new surfaces formation in the following form [7, 9, 15]:

$$\begin{cases} D_j(t) = Vt - u_j(t) - L_{j-1}(t - t_{j-1}) + A - H_{0j}, \\ h_j(t) = \max[0, D_j(t)], \\ L_j(t) = L_{j-1}(t - t_{j-1}) + h_j(t), \end{cases} \quad (3)$$

where (see figure 1,a): $D_j(t)$ is the distance between cutting edge of the j -th cutter and the surface treated by the previous $(j-1)$ -th cutter at the moment $t - t_{j-1}$; $L_j(t)$ is the distance from the right end of the part to the surface generated by the j -th cutter; A stands for the distance measured from the initial position of the cutting edge of the first cutter to the right end of the workpiece; H_{0j} is the axial offset of j -th cutter relative to the first one, for which the distance A is measured; t stands for current time.

Equations {(1) - (3)} are a system of differential-algebraic equations with several delays describing the dynamics of multi-cutter turning. These equations allow considering the regenerative mechanism of oscillations excitation in the system: a new surface resulting on the current processing cycle contains information about all previous tool passes.

Let us reduce the system of equations {(1) - (3)} to dimensionless form by taking the feed per revolution h_0 as a linear scale X_* , as a time scale $T_* = \sqrt{\sum_{i=1}^n T_i^2/n}$, $T_i = 2\pi\sqrt{m_j/k_j}$, T_i is a period of the cutters natural oscillations; as a cutting force scale $F_* = K_0 h_0$.

Then in case of the identical cutters and equality of their fixing conditions $(m_i = m, k_i = k, d_i = d, T_i = T = T_*, i = \overline{1, n})$ the equations in dimensionless form take the form:

$$\begin{cases} \Delta_j(\tau) = \tau/\rho - \xi_j(\tau) - A_{j-1}(\tau - \tau_{j-1}) + A - H_{0j}, \sum_{j=1}^n \tau_j = \rho, \\ \eta_j(\tau) = \max(0, \Delta_j(\tau)), \Pi_j = \eta_j(\eta_* + r\eta_j) / (\eta_* + \eta_j) \\ 0 = -A_j(\tau) + A_{j-1}(\tau - \tau_{j-1}) + \eta_j(\tau), \\ \xi_j' = -4\pi\zeta \xi_j' - 4\pi^2 \xi_j + 4\pi^2 \kappa \Pi_j, j = \overline{1, n} \end{cases} \quad (4)$$

where the following dimensionless quantities and complexes are introduced:

$$\xi_j = \frac{u_j}{h_0}, \zeta = \frac{d}{2\sqrt{mk}}, \kappa = \frac{K_0}{k}, \eta_j = \frac{h_j}{h_0}, \eta_* = \frac{c}{h_0}, \Pi_j = \frac{F_j}{K_0 h_0},$$

$$A_j(\tau) = \frac{L_j}{h_0}, \Delta_j = \frac{D_j}{h_0}, c = \frac{2\pi}{\omega T_*}, A = \frac{A}{h_0}, H_{0j} = \frac{H_{0j}}{h_0} \quad (5)$$

ρ is ratio of the cutters natural frequency to the frequency of the workpiece rotation and equals to the dimensionless time of one revolution of the workpiece (the parameter $1/\rho$ is a dimensionless cutting speed); k is relative static cutting stiffness, which, in this case, are the same for the zones of interaction between the cutters and the workpiece; Π_j is a dimensionless axial component of the cutting force.

Two-cutter turning. In the particular case of two-cutter turning, the cutters divide the circumference of the workpiece cross-section into two unequal parts (figure 2), which are determined by the angles $\varphi_1 = \pi + \Delta\varphi$ and $\varphi_2 = \pi - \Delta\varphi$, $\Delta\varphi$ is deviation of the angle between the cutters from π .

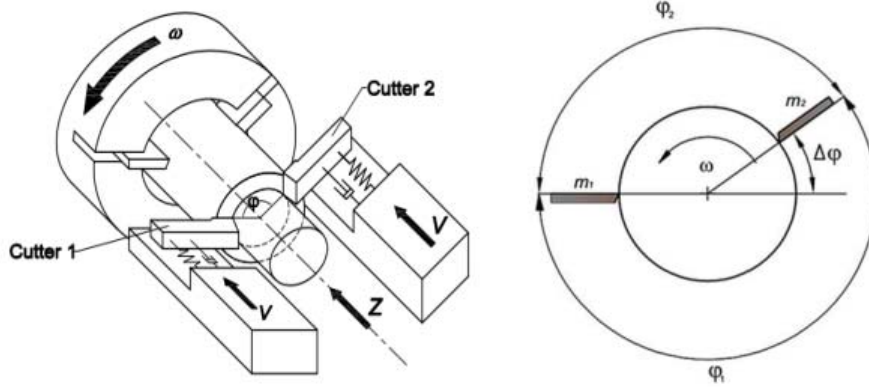

Figure 2 – Design scheme of two-cutter turning

The dynamics equations (4) for two-cutter turning are written in the following form:

$$\left\{ \begin{array}{l} \Delta_j(\tau) = \frac{\tau}{\rho} - \xi_j(\tau) - A_j(\tau - \tau_j) + A - (j - 1)H_0, \\ \eta_j(\tau) = \max(0, \Delta_j(\tau)), A_j(\tau) = A_j(\tau - \tau_j) + \eta_j(\tau), \\ \Pi_j = \eta_j(\eta_* + r\eta_j) / (\eta_* + \eta_j) \\ \xi_j'' = -4\pi\zeta\xi_j' - 4\pi^2\xi_j + 4\pi^2\kappa\Pi_j, j = 1, 2; J = \text{mod}(j - 2, 2) + 1 \end{array} \right. \quad (6)$$

with the initial condition $A_{j0}(0) = A_{j0}(-\tau_j)$. In this case, the values of the delays are normalized as follows: $\tau_1 = \rho\varphi_1/2\pi$, $\tau_2 = \rho\varphi_2/2\pi$, $\rho = \tau_1 + \tau_2$.

Continuous cutting is characterized by the fact that $\Delta_{1,2}(\tau) \geq 0 \forall \tau$. In this case the complete system of equation (6) can be simplified, and we may consider only the equations for the cutters deviations:

$$\left\{ \begin{array}{l} \xi_j''(\tau) = -4\pi\zeta\xi_j'(\tau) - 4\pi^2\xi_j(\tau) + 4\pi^2\kappa\Pi_j(\tau), \\ \Pi_j(\tau) = \eta_j(\eta_* + r\eta_j(\tau)) / (\eta_* + \eta_j(\tau)), \\ \eta_j(\tau) = \frac{\tau_j}{\rho} + \xi_j(\tau - \tau_j) - \xi_j(\tau), j = 1, 2, J = \text{mod}(j - 2, 2) + 1 \end{array} \right. \quad (7)$$

Stationary continuous turning is an unperturbed motion ($\xi_j(\tau) = \xi_{j0} = \text{const}$, $\eta_j = \eta_{j0} = \text{const}$), for which the parameters of the removing layer thickness are determined by the following relationships:

$$\left\{ \begin{array}{l} \eta_{10} = \tau_2/\rho - \xi_{10} + \xi_{20} + H, \eta_{20} = \tau_1/\rho - \xi_{20} + \xi_{10} - H \\ \Pi_{j0} = \eta_{j0} \frac{\eta_* + r\eta_{j0}}{\eta_* + \eta_{j0}}, \xi_{j0} = \kappa\Pi_{j0}, j = 1, 2 \end{array} \right. \quad (8)$$

Equations in variations near the unperturbed motion (8) for equations (7) have the form

$$\begin{cases} \delta \xi_1'' + 4\pi\zeta\delta \xi_1' + 4\pi^2\delta \xi_1 = 4\pi^2\kappa\rho_1(-\delta \xi_1(\tau) + \delta \xi_2(\tau - \tau_2)), \\ \delta \xi_2'' + 4\pi\zeta\delta \xi_2' + 4\pi^2\delta \xi_2 = 4\pi^2\kappa\rho_2(-\delta \xi_2(\tau) + \delta \xi_1(\tau - \tau_1)). \end{cases} \quad (9)$$

$$\rho_j = \left. \frac{\partial \Pi_j}{\partial \eta_j} \right|_{\eta_j = \eta_{j0}} = r + \frac{\eta_*^2(1-r)}{(\eta_* + \eta_{j0})^2}, j = 1, 2$$

The characteristic equation is obtained from (9) by substituting the solution in the form of $\delta \xi_j = \exp(\lambda\tau)C_j$:

$$\begin{aligned} P(\lambda; \zeta, \rho, \kappa) &= \dots \\ &= [\lambda^2 + 4\rho\zeta\lambda + 4\pi^2(1 + \kappa\rho_1)][\rho\lambda^2 + 4\pi\zeta\lambda + 4\pi^2(1 + \kappa\rho_2)] - \dots \\ &\dots - 16\pi^4\kappa^2\rho_1\rho_2\exp(-\lambda\rho) = 0. \end{aligned} \quad (10)$$

On the boundaries of the motion stability regions (8), the characteristic value λ is equal to the purely imaginary value $\lambda = 2\pi is, s \in \mathbb{R}$. From equation (10) the boundaries $\{\kappa(s), \rho(s)\}$ can be found in parametric form (figure 3):

$$\Gamma = \{\kappa(s), \rho(s) \mid \text{Re}(P(is; \zeta, \rho, \kappa)) = 0, \text{Im}(P(is; \zeta, \rho, \kappa)) = 0, s \in (0, \infty)\} \quad (11)$$

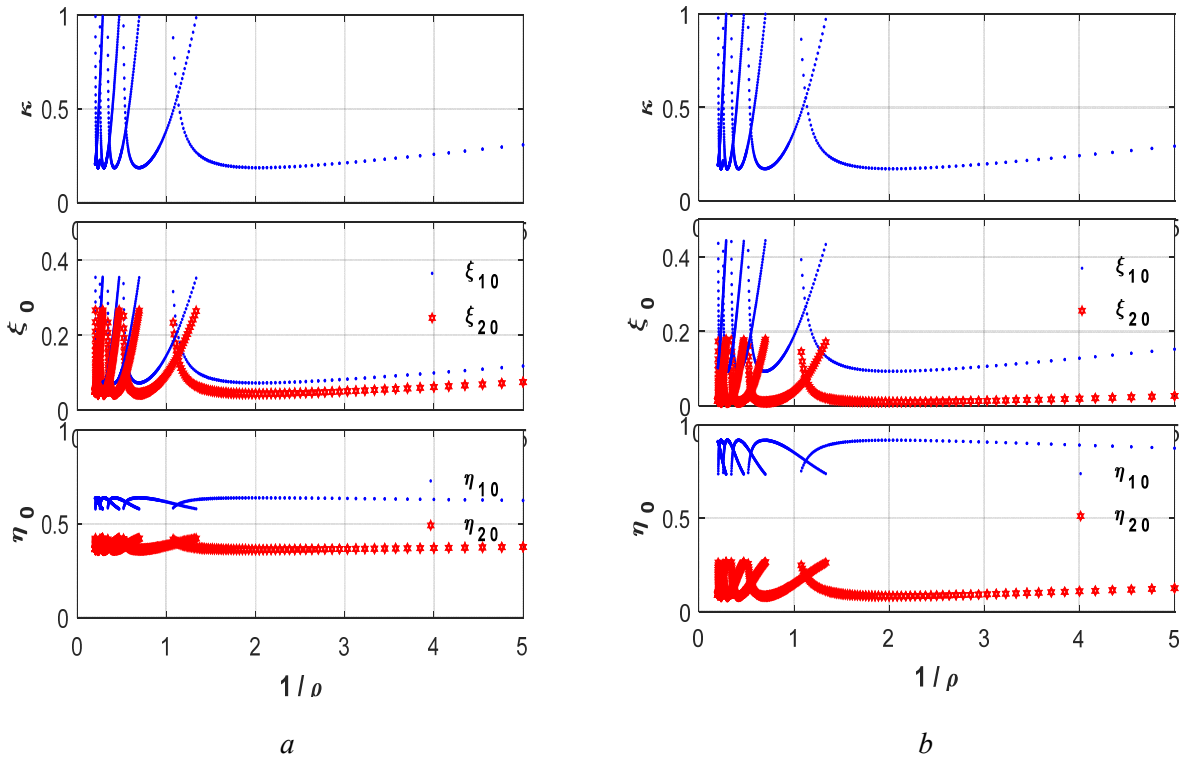

Figure 3 – Different representations of the stability diagram:

a: $\{\tau_1/\tau_2 = 2, H = 0, \eta_* = 0.1, \zeta = 0.05, r = 0.55\}$, b: $\{\tau_1/\tau_2 = 1, H = 0.5, \eta_* = 0.1, \zeta = 0.05, r = 0.55\}$

It should be noted that the quantities κ, ρ appear in **Ошибка! Источник ссылки не найден.** both explicitly and indirectly via $\rho_j, \eta_{j0}, \xi_{j0}$. That is, the equations **{Ошибка! Источник ссылки не найден. -Ошибка! Источник ссылки не найден.}** are to be solved together when calculating the stability boundaries **Ошибка! Источник ссылки не найден.**

Intermittent cutting numerical modelling. The complete system of equations of dynamics (6) is a system of differential-algebraic equations with retarded argument. For numerical integration, it is transformed into a system of differential equations with retarded argument: **ddae–dde** [17].

$$\begin{cases} \varepsilon A_j'(\tau) = A_j(\tau) + A_j(\tau - \tau_j) + \eta_j(\tau) \\ \xi_j'' = -4\pi\zeta\xi_j' - 4\pi^2\xi_j + 4\pi^2\kappa\Pi_j, j = 1, 2, J = \text{mod}(j - 2, 2) + 1 \end{cases} \quad (12)$$

$$\begin{cases} \Delta_j(\tau) = \tau/\rho - \xi_j(\tau) - A_j(\tau - \tau_j) + A - (j - 1)H \\ \eta_j(\tau) = \max(0, \Delta_j(\tau)); \Pi_j = \eta_j(\eta_* + r\eta_j)/\eta_* + \eta_j \end{cases}$$

Consider the cutting process, corresponding to the working point $\{\kappa = 0.5, \rho = 0.5\}$ in the diagrams in figure 3.

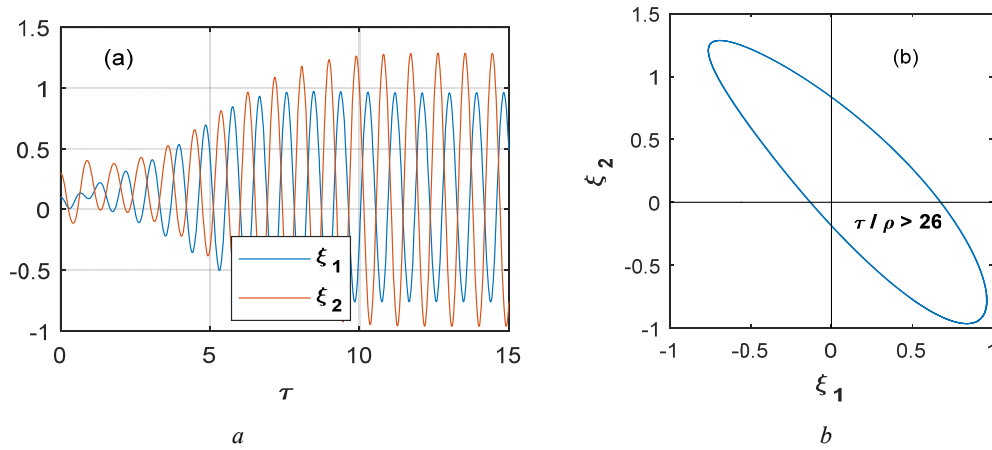

Figure 4 – Cutters oscillations (a), synchronization of two cutters oscillations (b)

Figure 4 shows the evolution of the cutter’s oscillations to steady regime in the case of an angular shift of the cutters by $240^\circ (\tau_1/\tau_2 = 2)$. Vibration stabilizes in about 15 workpiece rotations. Then the oscillations synchroniz (figure 4,b).

Figure 5 shows the evolution of the chips under the same conditions. One can see that the cutters work differently. Angle shift of the cutters allows controlling the work of the cutting edges.

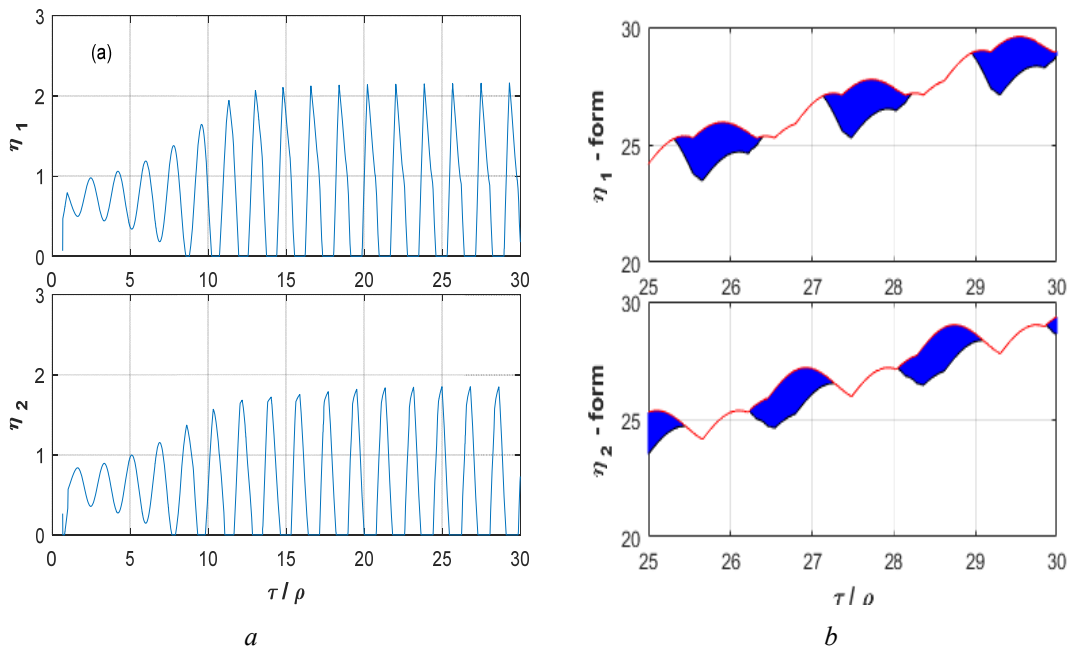

Figure 5 – The chips thickness (a) and the cross-sectional shape of the chips changing (b)

Conclusions. The considered model of two-cutter turning taking into account the compliance of the cutting tool fixation allows one:

- To investigate parametrically the stability of continuous stationary turning.
- To study the effect of axial and angular relative disposition of the cutters on the stability and the process of chips formation.

- Using the reduction of algebraic evolution equations to singular differential equations allows using standard procedures for integrating systems of differential equations with retarded argument (dde23 in MATLAB)

Acknowledgment. The work was supported by the Russian Foundation for Basic Research (project № 16-58-150001 НЦНИ_a) and by the French National Center for Scientific Research (project №263581).

**А. М. Гуськов^{1,2}, М. А. Гуськов³, Г. Я. Пановко^{1,2}, А. Е. Шохин¹,
М. Н. Қалимолдаев⁴, З. Ф. Уәлиев⁵**

¹А. А. Благонравов атындағы Машинажасау институты РҒА, Мәскеу, Ресей,

²Н. Е. Бауман атындағы ММТУ, Мәскеу, Ресей,

³PIMM зертханасы UMR 8006, ENSAM, CNRS, CNAM, Париж, Франция,

⁴Ақпараттық және есептеуіш технологиялар институты, Алматы, Қазақстан,

⁵Абай атындағы Қазақ ұлттық педагогикалық университеті, Алматы, Қазақстан

КӨП КЕСКІШ КЕСУ ДИНАМИКАСЫНЫҢ ЕРЕКШЕЛІКТЕРІ

Аннотация. Жұмыста көп кескішті қайрау кезінде үздіксіз кесу үрдісінің динамикасының ерекшеліктері және математикалық моделдеудің нәтижелері талқыланады. Созылған цилиндрлік бөлшектің көп кескіш нүктесінде өңдеу параметрлерінің дірілдің козуына әсері зерттеледі. Кескіштердің бекітілу қаттылығына және олардың өзара орналасуына байланысты кескіштің және түзілетін жоңқаның тербелісінің әртүрлі формалары талданады.

Модельдеудің негізіне қозғалыс теңдеулері, бөлшектік-рационалды функция түріндегі кесу заңы және бірнеше кешігуі бар дифференциалды-алгебралық теңдеулер жүйесі болып табылатын жаңа беттердің түзілу теңдеулері алынған және із бойынша көп кескіш нүктенің динамикасын сипаттайды. Бұл теңдеулер жүйедегі тербелістерді козудың регенеративті механизмін ескеруге мүмкіндік береді. Жұмыста кескіштердің бұрыштық жылжуы кезінде тұрақты тербеліске шығуының эволюциясы көрсетілген, жоңқаның эволюциясы көрсетілген, кескіштердің бұрыштық ығысуы кескіш жиектерінің жұмысын басқаруға мүмкіндік беретін кескіштердің жұмысының мысалы келтірілген. Жұмыста орнықтылықты жоғалту және автотербелістердің козу себептері атап өтілді. Дифференциалдық теңдеулер жүйесін кешіктіретін аргументпен интегралдау процедурасы көрсетілген, кескіштердің бекітілуін ескере отырып, екі кескіш нүктенің моделі қарастырылған.

Технологиялық жүйе параметрлерінің үзілісіз кесу режимінің тұрақтылығына әсері талданады.

Түйін сөздер: көп кескішті қайрау, динамика, модельдеу, үзілісіз кесу, автотербелістер, тұрақтылық, кешігу.

**А. М. Гуськов^{1,2}, М. А. Гуськов³, Г. Я. Пановко^{1,2}, А. Е. Шохин¹,
М. Н. Калимолдаев⁴, З. Г. Уалиев⁵**

¹Институт машиноведения им. А. А. Благонравова РАН, Москва, Россия,

²МГТУ им. Н. Э. Баумана, Москва, Россия,

³PIMM Laboratory UMR 8006, ENSAM, CNRS, CNAM, Paris, France,

⁴Институт информационных и вычислительных технологий, Алматы, Казахстан,

⁵Казахский национальный педагогический университет им. Абая, Алматы, Казахстан

ОСОБЕННОСТИ ДИНАМИКИ МНОГОРЕЗЦОВОГО РЕЗАНИЯ

Аннотация. В работе обсуждаются особенности динамики процесса непрерывного резания при много-резцовом точении и результаты математического моделирования. Исследуется влияние параметров обработки на возбуждение вибрации при многорезцовом точении протяженной цилиндрической детали. В зависимости от жесткости крепления резцов и их взаимного расположения анализируются различные формы колебаний резца и образующейся стружки.

В основу моделирования положены уравнения движения, закон резания в виде дробно-рациональной функции и уравнения образования новых поверхностей, которые представляют собой систему дифференциально-алгебраических уравнений с несколькими запаздываниями и описывают динамику многорезцового точения по следу. Эти уравнения позволяют учитывать регенеративный механизм возбуждения колебаний в системе. В работе показана эволюция выхода резцов на стационарные колебания при угловом сдвиге резцов, показана эволюция стружки, приводится пример работы резцов, угловой сдвиг которых позволяет управлять работой режущих кромок. В работе отмечены причины потери устойчивости и возбуждения автоколебаний. Показана процедура интегрирования систем дифференциальных уравнений с запаздывающим аргументом, рассмотрена модель двухрезцового точения с учетом податливости крепления резцов.

Анализируется влияние параметров технологической системы на устойчивость непрерывного режима резания.

Ключевые слова: многорезцовое точение, динамика, моделирование, непрерывное резание, автоколебания, устойчивость, запаздывание.

Information about authors:

Gousskov Alexander Mikhailovich, professor, Dr.Hab.Eng.Sci., Professor of Bauman Moscow State Technical University, chief researcher of Mechanical Engineering Research Institute of the Russian Academy of Sciences; gousskov_am@mail.ru; <https://orcid.org/0000-0002-8489-3867>

Gousskov Mikhail Alexandrovich, Ph.D. Eng.Sci., Associate Professor of Arts et Métiers ParisTech (PIMM Laboratory UMR 8006, ENSAM, CNRS, CNAM, Paris, France); mikhail.gousskov@ensam.eu; <https://orcid.org/0000-0001-5877-9449>

Panovko Grigory Yakovlevich, Honored Scientist of the Russian Federation, Dr.Hab.Eng.Sci., Head of the laboratory of vibromechanics of Mechanical Engineering Research Institute of the Russian Academy of Sciences, professor of Bauman Moscow State Technical University; gpanovko@yandex.ru; <https://orcid.org/0000-0002-7457-6374>

Shokhin Alexander Evgenevich, Ph.D.Eng.Sci., senior researcher of Mechanical Engineering Research Institute of the Russian Academy of Sciences; shohinsn@mail.ru; <https://orcid.org/0000-0002-2925-9759>

Kalimoldayev Maksat Nuradilovich, Doctor of Physics and Mathematics, Professor, Academician of NAS RK, General Director of the Institute of Information and Computational Technologies; mnk@ipc.kz; <https://orcid.org/0000-0003-0025-8880>

Ualiyev Zair Gakhipovich, Professor, Dr.Hab.Eng.Sci., Deputy Director for science work and international cooperation, Institute of Mathematics, Physics and Informatics, Abai Kazakh National Pedagogical University; z.ualiyev@mail.ru; <https://orcid.org/0000-0002-6476-2130>

REFERENCES

- [1] Smith G.T. (2008) Cutting Tool Technology. Industrial Handbook. Springer – Verlag, 599 p. ISBN 978-1-84800-205-0
- [2] Ozlu E., Budak E. (2009) Comparison of one-dimensional and multi-dimensional models in stability analysis of turning operations // *Machine Tools and Manufacture*. 47. P. 1042-1047. doi:10.1007/s10409-013-0097-z (in Eng.).
- [3] Dassanayake A.V., Suh C.S. (2008) On nonlinear cutting response and tool chatter in turning operation // *Communications in Nonlinear Science and Numerical Simulation*. 13. P. 979-1001 (in Eng.).
- [4] Astashev V.K., Korendyasev G.K. (2012) Thermomechanical model of the occurrence of oscillations in metal cutting // *J. of Machinery Manufacture and Reliability*. 41(3). P. 189-193. doi:10.3103/S105261881203003X (in Eng.).
- [5] Chen C.K., Tsao Y.M. (2006) A stability analysis of regenerative chatter in turning process without using tailstock // *Advanced Manufacturing Technology*. 29. P. 648-654 (in Eng.).
- [6] Otto A., Khasawneh F.A., Radons G. (2015) Position-dependent stability analysis of turning with tool and workpiece compliance // *Advanced Manufacturing Technology*. 79(9-12). P. 1453-1463 (in Eng.).
- [7] Gerasimenko A.A., Gousskov M.A., Gousskov A.M., Lorong Ph., Panovko G.Ya. (2016) Analytical approach of turning thin-walled tubular parts. Stability analysis of regenerative chatter // *Vibroengineering Procedia*. 8. P. 179-184 (in Eng.).
- [8] Wang X., Feng C.X. (2002) Development of Empirical Models for Surface Roughness Prediction in Finish Turning // *Advanced Manufacturing Technology*. 20(5). P. 348-356 (in Eng.).

-
- [9] Gousskov A.M., Voronov S.A., Paris H., Batzer S.A. (2002) Nonlinear dynamics of a machining system with two interdependent delays // *Communications in Nonlinear Science and Numerical Simulation*. 7(3). P. 207-221. doi:10.1016/S1007-5704(02)00014-X (in Eng.).
- [10] Sherov K.T., Sikhimbayev M.R., Absadykov B.N., Sikhimbayeva D.R., Buzauova T.M., Karsakova N.G., Gabdysalyk R. (2018) Control's accuracy improvement and reduction of labor content in adapting of ways of metalcutting tools // *News of the National academy of sciences of the Republic of the Kazakhstan. Series of geology and technical sciences*. Vol. 6(432). P. 170-177. <https://doi.org/10.32014/2018.2518-170X.47> (in Eng.).
- [11] Kozochkin M.P. (2013) *Dynamic of cutting process. Theory, experiment, analysis*. Lambert Academic Publishing. ISBN 978-3-659-42793-0 (in Rus.).
- [12] Kudinov V.A. (1967) *Dynamics of machine tools*. M.: Mashinostroenie. 357 p. (in Rus.).
- [13] Kondratenko K.A., Gousskov A.M., Gousskov M.A., Lorong Ph., Panovko G.Ya. (2014) Analysis of indirect measurement of cutting forces turning metal cylindrical shells. *Proceedings of Proceedings of VETOMAC X, Manchester, UK*. P. 929-937. doi:10.7463/0214.0687971
- [14] Lamikiz A., Lopez de Lacalle L.N., Sanchez J.A., Bravo U. (2005) Calculation of the specific cutting coefficients and geometrical aspects in sculptured surface machining // *Machining Science and Technology*. 9(3). P. 411-436. doi:10.1080/15321790500226614 (in Eng.).
- [15] Gousskov A.M., Gousskov M.A., Lorong Ph., Panovko G.Ya. (2017) Influence of the clearance face on the condition of chatter self-excitation during turning // *Machining and Machinability of Materials*. 19(1). P. 17-39. doi:10.1504/IJMMM.2017.10002088 (in Eng.).
- [16] Benardos P.G., Mosialos S., Vosniakos G.C. (2002) Prediction of workpiece elastic deflections under cutting forces in turning // *Robotics and Computer-Integrated Manufacturing*. 22. P. 505-514 (in Eng.).
- [17] Brissaud D., Gousskov A., Guibert N., Rech J. (2008) Influence of the ploughing effect on the dynamic behavior of the self-vibratory drilling head // *CIRP Annals - Manufacturing Technology*. 57(1). P. 385-388. doi:10.1016/j.cirp.2008.03.101 (in Eng.).
- [18] Dombovari Z., Barton D.A.W., Wilson R.E., Stepan G. (2011) On the global dynamics of chatter in the orthogonal cutting model // *Non-linear Mechanics*. 46. P. 330-338. doi:10.1016/j.ijnonlinmec.2010.09.016 (in Eng.).
- [19] Kalidasan R., Yatin M., Sarma D.K., Senthilvelan S., Dixit U.S. (2016) An experimental study of cutting forces and temperature in multi-tool turning of grey cast iron // *Machining and Machinability of Materials*. 18(5/6). P. 540-551. doi:10.1504/IJMMM.2016.078992 (in Eng.).
- [20] Gousskov A.M., Gousskov M.A., Ding Dyk Tung, Panovko G. (2018) Multi-cutter turning process stability analysis // *Vibroengineering Procedia*. 17. P. 124-129. <https://doi.org/10.21595/vp.2018.19800> (in Eng.).
- [21] Ozturk E., Comak A., Budak E. (2016) Tuning of tool dynamics for increased stability of parallel (simultaneous) turning processes // *Sound and Vibration*. 6(360). P. 17-30. doi:10.1016/j.jsv.2015.09.009 (in Eng.).
- [22] Reith M.J., Bachrathy D., Stepan G. (2016) Improving the stability of multi-cutter turning with detuned dynamics // *Machining Science and Technology*. 20(3). P. 440-459. doi:10.1080/10910344.2016.1191029 (in Eng.).
- [23] Gousskov A.M., Voronov S.A., Paris H., Batzer S.A. (2001) Cylindrical Workpiece Turning Using Multiple-Cutting Tool, *Proceedings of the Design Technical Conferences and Computers and Information Engineering Conference*, September 9-12, 2001. Pittsburgh, Pennsylvania.
- [24] Suslov A.G., Dal'skij A.M. (2002) *Nauchnye osnovy tekhnologii mashinostroeniya (Scientific bases of technology of mechanical engineering)*. M.: Mashinostroenie. 684 p. ISBN 5-217-03108-5 (in Rus.).
- [25] Chang Kai. (2009) *Machining Dynamics. Fundamentals, Applications and Practices*. Springer-Verlag, London Limited. ISBN 971-1-84628-368-0
- [26] Grasman J. (1987) *Asymptotic Methods for Relaxation Oscillations and Applications*. Springer – Verlag, New-York Inc. ISBN 0-387-965 13-0
- [27] Tihonov A.N., Goncharskij A.V., Stepanov V.V., Yagola A.G. *Chislennyye metody resheniya nekorrektnykh zadach (Numerical methods for solving ill-posed problems)*. M.: Nauka, 1990. 232 p.
- [28] Kenzhaliyev B.K., et al. To the question of recovery of uranium from raw materials // *News of the National academy of sciences of the Republic of Kazakhstan. Series of geology and technical sciences*. 2019. Vol. 1. P. 112-119. <https://doi.org/10.32014/2019.2518-170X.14>
- [29] Kenzhaliyev B.K., Kvyatkovskiy S.A., Kozhakhmetov S.M., Sokolovskaya L.V., Semenova A.S. Depletion of waste slag of balkhash copper smelter // *Kompleksnoe Ispol'zovanie Mineral'nogo syr'ya*. 2018. Vol. 3. P. 45-53. <https://doi.org/10.31643/2018/6445.16>
- [30] Kenzhaliyev B.K., Trebukhov S.A., Volodin V.N., Trebukhov A.A., Tuleutay F.Kh. Izvlecheniye selena iz promproduktov metallurgicheskogo proizvodstva // *Kompleksnoye ispol'zovaniye mineral'nogo syr'ya*. 2018. Vol. 4. P. 56-64. <https://doi.org/10.31643/2018/6445.30>