

## ***Polymer-drug nanoconjugate – an innovative nanomedicine: challenges and recent advancements in rational formulation design for effective delivery of poorly soluble drugs.***

\*Amos O. Abioye<sup>1</sup>; George Tangyie Chi<sup>1</sup>; Adeola T. Kola-Mustapha<sup>2</sup>; Ketan Ruparelia<sup>1</sup>; Ken Beresford<sup>1</sup>; Randolph Arroo<sup>1</sup>

<sup>1</sup>Leicester School of Pharmacy, De Montfort University, The Gateway, Leicester, LE1 9BH, UK

<sup>2</sup>Department of Pharmaceutics and Industrial Pharmacy, Faculty of Pharmaceutical Sciences, University of Ilorin, Nigeria

\*Corresponding Author: Amos Olusegun Abioye

Email: [aabioye@dmu.ac.uk](mailto:aabioye@dmu.ac.uk)

Phone: +44 (0) 116 207 8669

Fax: +44 (0) 116 257 7287

### **Abstract**

**Background:** Over the last four decades, the use of water soluble polymers in rational formulation design has rapidly evolved into valuable drug delivery strategies to enhance the safety and therapeutic effectiveness of poorly soluble drugs, particularly anticancer drugs. Novel advances in polymer chemistry have provided new generations of well defined polymeric architectures for specific applications in polymer-drug conjugate design. However, total control of crucial parameters such as particle size, molecular weight distribution, polydispersity, localization of charges, hydrophilic-lipophilic balance and non site-specific coupling reactions during conjugation has been a serious challenge. **Objective:** This review briefly describes the current advances in polymer-drug nanoconjugate design and various challenges hindering their transformation into clinically useful medicines. **Method:** Existing literature was reviewed. **Results:** This review provides insights into the significant impact of covalent and non-covalent interactions between drug and polymer on drug loading (or conjugation) efficiency, conjugate stability, mechanism of drug release from the conjugate and biopharmaceutical properties of poorly soluble drugs. The utility values and application of Quality by Design principles in rational design, optimization and control of the Critical Quality Attributes (CQA) and Critical Process Parameters (CPP) that underpin the safety, quality and efficacy of the nanoconjugates are also presented. **Conclusion:** It was apparent that better understanding of the physicochemical properties of the nanoconjugates as well as the drug-polymer interaction during conjugation process is essential to be able to control the biodistribution, pharmacokinetics, therapeutic activity and toxicity of the nanoconjugates which will in turn enhance the prospect of successful transformation of these promising nanoconjugates into clinically useful nanomedicines.

### **Table of Contents**

Abstract .....	1
1.0 Introduction.....	2
1.1 Polymer-drug conjugates.....	4
1.2 Polymeric nanoconjugates: innovative, not innocent drug delivery systems .....	7
2.0 Rational design of nanoconjugate formulations .....	8
2.1 Tumour targeted polymer-drug nanoconjugates.....	10
2.1.1 Passive targeting .....	12
2.1.2 Active targeting .....	13
2.2 Polymer-drug nanoconjugates targeting other diseases.....	14
2.3 Types of polymer-drug conjugates .....	14
2.3.1 Multiple drug-polymer conjugates for cancer treatment .....	16

2.4	Selection of suitable polymers.....	17
2.4.1	Natural polysaccharides.....	17
2.4.2	Synthetic polymers .....	20
3.0	Preparation of polymer-drug nanoconjugates.....	23
3.1	Dispersion of active drug in preformed polymers .....	24
3.1.1	Solvent emulsification-diffusion (SED) .....	24
3.1.2	Nanoprecipitation or solvent displacement .....	24
3.1.3	Salting-out .....	24
3.2	Polymerization of monomers.....	25
4.0	Drug loading strategies.....	25
5.0	Optimization of nanoconjugates formulations .....	28
5.1	Quality by Design (QbD) principles.....	29
6.0	Nanoconjugate characterization .....	30
7.0	Nanoconjugate stabilization.....	31
7.1	Steric stabilization .....	31
7.2	Electrostatic stabilization.....	32
8.0	Conclusion .....	32
	References.....	32

## 1.0 Introduction

Poorly soluble drugs represent more than 40% of the drugs in the product development pipelines while about 60% of the synthetic analogues and 90% of approved drugs have been reported to have poor solubility, poor permeability or both (1) presenting major challenges in formulation design and product development which in turn impact therapeutic outcomes. In corollary most of the potent drug candidates discovered through high-throughput screening, combinatorial chemistry, informatics and miniaturization failed to reach the market because of poor biopharmaceutical properties. Those that made it to the market exhibit poor pharmacokinetics and inadequate bio-distribution resulting in unwanted and toxic side effects.

It is common knowledge that drug molecules have to be soluble in water to be readily delivered to the cellular membranes therefore aqueous solubility of active pharmaceutical ingredients is a key parameter in formulation design and product development (2). In the same vein they need to exhibit some hydrophobic characteristics in order to cross absorption membranes. Therefore a balance of both properties is required for the delivery of water-insoluble drugs to therapeutic target sites. This requirement has presented significant difficulties in development and delivery of poorly soluble drugs because they tend to be eliminated from the gastro-intestinal tract before they have opportunity to dissolve fully and be absorbed into the circulation especially when administered orally. Also, because some poorly soluble drugs exhibit low molecular weight and short biological half-life they tend to have large volume of distribution, short circulation time, slow and ineffective absorption as well as low systemic bioavailability. Consequently relatively small amount of the drug reach the target site requiring the use of high and multiple daily doses which could lead to wasted dosing, low efficacy, potentially

serious undesirable side effects and in some cases therapeutic failure and multiple drug resistance (3,4). In order to solve these problems, extensive research efforts have been focused on drug-polymer complexes (conjugates) in the past four decades. Biodegradable hydrophilic polymers with bio-mimetic characteristics are frequently used to control the particle size, surface characteristics, solubility and release mechanisms of various poorly soluble drugs. In general, incorporation of bioactive agents into hydrophilic polymers has shown tremendous advantages over the free drugs, including increased solubility in biological fluids, enhanced drug absorption and bioavailability (5-7); reduced systemic toxicity and better tolerability (8); passive tumour targeting due to enhanced permeability and retention (EPR) effect (9) promoting accumulation and preferential uptake of the active drugs by targeted cells; improved pharmacokinetics, biodistribution, programmed drug release profile and therapeutic effectiveness (7,10-12) as well as ability to bypass some mechanisms of drug resistance (13). They also protect the bioactive agents from premature degradation and reduce the cost of production. This enormous potential of polymer-drug conjugates is due to their small size and large surface area-to-volume ratio which enable good tissue penetration and high cellular uptake. This phenomenon is of great value in optimization of drug therapy and site-specific drug targeting. However in spite of the extensive research efforts to date in this area, the development of novel polymer-drug nanoconjugate systems with well defined homogeneous architecture and drug loading efficiency that can maximize plasma concentration and site-specific targeting efficiency as well as minimizing toxic side effects is an ongoing challenge. Therefore transformation of polymer-drug conjugates into clinically useful medicines for clinical evaluation and regulatory approval has been a difficult task. This article reviews the challenges and recent advancements in polymer-drug conjugates as well as the role of rational formulation design in harnessing the potentials of these nanostructures to develop efficient drug delivery tools for poorly soluble drugs.

Presently, many poorly soluble active pharmaceutical ingredients (APIs) are produced by organic solvent synthesis and crystallization techniques (e.g. ibuprofen) which usually require large volumes of the solvent (e.g. hexane, heptane, methanol *etc.*) to ensure complete dissolution of the components. In most cases, the solvents are removed by various techniques including vacuum drying, spray drying, fluidized bed drying, lyophilisation *etc.* making the process more cumbersome and expensive. In the same vein almost all techniques reported in literature, for the preparation of polymer-drug conjugates, involve the use of organic solvent and toxic chemical initiator. However the residual amount of solvent remaining in the final product has not been addressed to date which could be of serious safety and environmental concerns. The International Committee for Harmonization (ICH) has published a guideline for limits of residual solvents in pharmaceutical products including class 1 solvents to be avoided, class 2 solvents to be limited and class 3 solvents with low toxicity potential (14). It is however important to note that solvents trapped within complex molecular structures are usually difficult to access or quantify. Hence development of solvent free drug delivery systems would be of great value.

The needle-like ibuprofen and ciprofloxacin crystals produced from the solvent crystallization (Fig. 1) exhibits strong cohesive and viscoelastic characteristics rendering it very difficult to formulate and research efforts to date have not been able to establish the desired improvement in its characteristics. Therefore new rational formulation approaches to optimize effective delivery of poorly soluble drugs represent a significant unmet need.

One approach towards improved therapeutic application of poorly soluble drugs is the preparation of amorphous polymer-drug conjugates which contain drugs in a physically bound (dissolved, dispersed, included or adsorbed) state or chemically linked (covalent bond) to the polymer backbone or as side groups from which the drug is delivered by chemically or biologically induced cleavage of the bond. This approach involves transformation of the crystalline active pharmaceutical ingredients (API), which is usually preferred in manufacturing due to their physicochemical stability, into amorphous form which is less stable. Therefore research efforts have been focused on stabilizing nanosized amorphous API particularly for poorly soluble drugs because the amorphous form is known to exhibit higher saturation solubility and dissolution velocity due to its ability to generate supersaturated drug solution during dissolution compared with the crystalline form (15,16). The higher dissolution rates have also been linked to higher bioavailability *in vivo* provided that supersaturation is sustained for sufficient period of time for absorption to occur (17-19). Stable amorphous polymer-drug nanoconjugate formulations are highly promising because they combine nanoscale formulation with enhanced solubility and bioavailability which may provide a platform for reduced dosing, toxicity and undesirable side effects of the API as well as controlled release and site specific nano-targeted drug delivery. Therefore this review will present the concept of low energy *green* approach where poorly soluble drugs are converted into stable size-controlled amorphous nanoconjugates in entirely aqueous system as well as the impact of polymer-drug interaction on drug loading efficiency and biopharmaceutical properties of the drug.

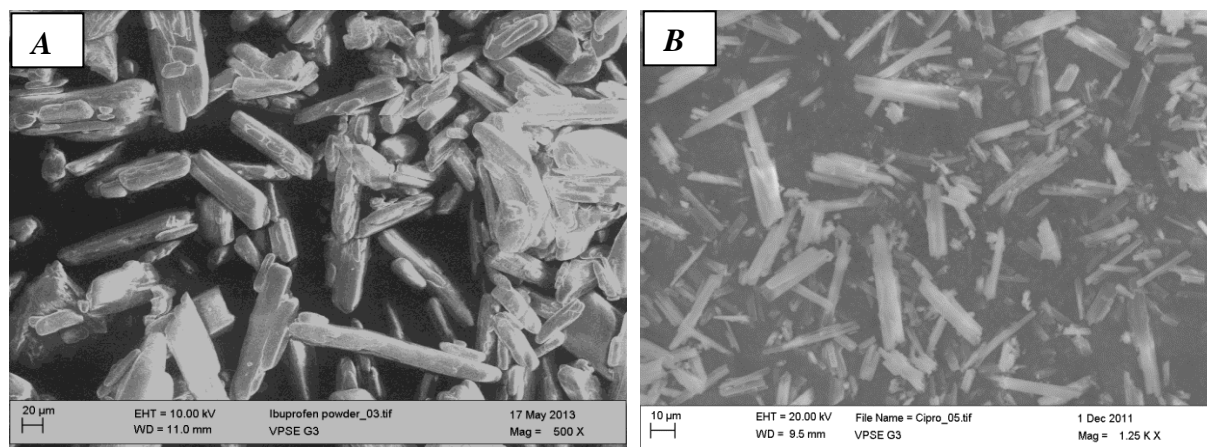

**Figure 1:** Representative photomicrographs of poorly soluble drugs A) ibuprofen and B) ciprofloxacin crystals

## 1.1 Polymer-drug conjugates

Polymer-drug conjugates (PDCs) are drug loaded polymeric nanoparticles in which the bioactive molecule (drug, protein, peptides, hormones, enzymes, growth factors *etc.*) is covalently attached to a water-soluble polymer backbone through a physiologically labile bond to protect the bioactive molecule from premature degradation providing longer systemic circulation time as well as enhancing absorption and bioavailability. The longer blood circulation time increases the probability for the conjugate to interact with its target providing the platform for enhanced therapeutic effectiveness and improved therapeutic index. In this case physicochemical properties of the PDCs such as particle size, surface charge, conformation and biocompatibility will dictate the efficiency of target delivery. Examples of PDCs include polymer-drug nanoconjugates; biologically active polymers; polymer-protein conjugates; polymer-antibody conjugates; drug loaded polymeric micelles and polymer-DNA complexes (polyplexes) for gene delivery *etc.* (11,24-26). Because of their distinctive pharmacokinetic profiles, they are considered as new chemical entities relative to their parent drugs, not conventional pharmaceutical dosage formulation or drug delivery systems that simply physically entrap the drug (5,7,11,26).

Polymer therapeutics, first described by Prof Ruth Duncan in 1990s, was the ‘*melting pot*’ for the current plethora of successful innovative and clinically important polymeric nanomedicines (polymer-drug conjugates) with remarkable physicochemical and biopharmaceutics properties. For instance, many polymer-protein conjugates have been approved for marketing since the 1990s such as Zinostatin stimalmer (styrene maleic anhydride neocarzinostatin, SMANCS), Adagen<sup>®</sup> (PEG-adenosine deaminase) and Oncaspar<sup>®</sup> (PEG-asparaginase). In the early 2000s the FDA approved subcutaneous injection of PEG-interferon conjugates (PEG-Intron; PEG-ASYS) for the treatment of chronic hepatitis C and recently (2011) PEG-interferon  $\alpha$ -2b (Sylatron) was approved as adjuvant therapy for the treatment of high-risk melanoma (27) while PEG-interferon  $\beta$ -1a is currently being tested in clinical trials (Phase III) for the treatment of multiple sclerosis (28).

In designing these nanostructures conjugation strategies are of prime importance. Some of the techniques described in the literature include enzymatic conjugation of doxorubicin with poly(ethylene glycol) multiblock copolymer through cleavable oligopeptide groups (29); grafting approaches such as oligopeptide sequences and reductive disulfide bonding (30); and construction of biodegradable star HPMA copolymer-drug conjugates by modifying PAMAM dendrimers with polyHPMA grafts through enzymatically cleavable or reducible linkers to facilitate degradation of high molecular weight polymers (31). For example the star polymer- doxorubicin conjugate has been shown to exhibit prolonged systemic circulation, increased tumour accumulation and therapeutic effectiveness in lymphoma tumour bearing mice (32). Another example is Opaxio, formerly branded as Xyotax, which is a conjugate of poly(L-glutamic acid) and paclitaxel. Poly(L-glutamic acid) was chosen because it is biodegradable and its breakdown product (L-glutamic acid) can enter normal metabolic process rather than being cleared through renal excretion. The  $\gamma$ -carboxylic acid side chains of the L-glutamic acid is conjugated to the 2' hydroxyl of paclitaxel through ester bond. Therefore the hydroxyl group is not available for binding to the tubulin for the required pharmacological activity, rendering it inactive. However the conjugate

exhibited higher maximum tolerated dose, water solubility and greater efficacy than paclitaxel formulated in Cremophor EL/ethanol. Recently the synthesis of biodegradable multiblock poly(HPMA) conjugates with well-defined physical and chemical properties has been conducted by a combination of reversible addition-fragmentation chain transfer (RAFT) polymerization and click chemistry (33,34). This technique involves three major stages including RAFT polymerization of HPMA using an enzyme sensitive Gly-Phe-Leu-Gly (GFLG) moiety containing a chain transfer agent (CTA) with a terminal alkyne group to modify the polymer; introduction of a terminal azide to produce an  $\alpha$ -alkyne ( $\omega$ -azido-telechelic poly(HPMA) and finally the synthesis of biodegradable multiblock poly(HPMA) by click chemistry in the presence of a copper catalyst. The concept of covalently conjugating a cleavable bioactive material (low molecular weight drug, protein, peptide, hormone, enzyme *etc.*) to hydrophilic polymer carrier (polymer-drug conjugates) through physiologically labile bond was first proposed by Helmut Ringsdorf in 1975 (35). This has been further explored to increase drug solubility, enhance disease specific targeting, control drug release, reduce drug toxicity, facilitate drug absorption across biological barriers and improve therapeutic effects of bioactive molecules (24,36,37).

Although there have been significant advances in the synthesis, characterization and understanding of *in vitro* and *in vivo* activities of the PDCs for about 40 years and is still attracting huge research interest especially in clinical oncology, none of the polymer-drug conjugates under intensive research efforts have yet reached the market (7,38). The slow progression of transforming polymer-drug conjugates into clinically useful medicines for clinical evaluation and regulatory approval has been associated with clinical failure as a result of '*wrong conjugate rational design*' that yielded non-specific drug release and biodistribution with deprived pharmacokinetic profiles (39). We hypothesize that the clinical failure may be linked to the obvious drawbacks of the polymer-drug conjugates which include heterogeneous composition, structure and particle size relative to conventional dosage forms. The heterogeneity of the polymeric conjugates may have resulted from the polydispersity and varying molecular weights of the polymer content, lack of control over the active site on the polymer backbone to which the drug is conjugated and lack of control over the chemo- and regio-selective conjugation of bioactive molecule containing multiple functional groups. The usual consequence is non-specific drug release profiles which may contribute to the failure at clinical trial stage. Therefore size-controlled rational design of polymer-drug nanoconjugate formulation tailored to predictive and controlled drug release would be of great value to enhance the propensity of clinical success of polymeric drugs. In this vein the inherent heterogeneity in polymeric nanoparticles could be reduced or eliminated by developing polymers with low polydispersity index or by conjugating bioactive molecule to the terminal reactive site on the polymer or by blocking undesirable conjugation of competing functional groups on the bioactive molecule through the use of protection moieties. In the same vein the modifiable physicochemical properties of these polymer-drug nanoconjugates (PDNs) including high surface to volume ratios, tunable size, surface functionality and their ability to interact with their environment can provide unique platform for the development of novel and more effective therapeutic and diagnostic agents for future treatment of difficult diseases such as cancer (40). In our opinion apart from the covalent polymer-drug conjugation, the interaction of nanoconjugates with their environment through non-covalent forces such as van der Waals, hydrogen bonding, electrostatic, hydrophobic and steric interactions should be considered because it may lead to non-intuitive behaviours of the conjugates which are critical for designing effective polymeric nanomedicines. We noticed that this phenomenon has not received any significant research attention in literature. Therefore more attention should be focused on quantitative understanding of the non-covalent polymer-drug nanoconjugate with respect to its stabilization, transport, drug release mechanism and drug uptake which underpin efficacy and stability of the nanoconjugates. These critical factors could reveal new insights into better rational nanoconjugate design and guide future criteria for rational formulation design which may accelerate transformation of PDCs into clinically useful nanomedicines. Other challenges include difficulty in achieving reproducible batch-to-batch synthesis and inadequate analytical tools for characterization of the complex multicomponent polymer conjugates (38,41). Therefore it has been difficult to satisfy the drug product quality and regulatory requirements including the metabolic fate of the conjugates relative to traditional formulations.

Current literature is replete with research efforts on quantitative techniques to evaluate homogeneity of the drug and ligand distribution in the preparation of PAMAM dendrimers (42,43) and the effect of physical instability (aggregation) of HPMA-folate conjugate on folate receptor-mediated uptake (44). Sophisticated analytical techniques such as small angle neutron scattering (SANS), 2D  $^1\text{H}$  NOESY and TOCSY NMR and pulsed gradient NMR have been used to characterize polymer-drug nanoconjugates (45,46). The release of the drug from the polymeric carrier as well as its safety and efficacy, are critical parameters that should also be monitored as the nanoconjugates frequently exhibit altered biodistribution and pharmacokinetics (47,48). If the release of the drug from the conjugates occurs prematurely during the systemic transport, undesirable side effects and toxicities may arise, reducing the overall safety profile of the drug. On the other hand the drug must

be released upon reaching the target site of action in order to achieve therapeutic efficacy. Presently anticancer drug conjugates Opaxio<sup>®</sup> (PGA-paclitaxel conjugate) and Etirinotecan Pegol (NKTR-102) – a PEG-irinotecan conjugate (Fig. 2), are in Phase III clinical trials in women with ovarian and metastatic breast cancers respectively (49).

Therefore rational design of polymeric nanoconjugates should provide a critical balance between conjugate stability and drug release kinetics which impact their safety and efficacy. Intensive research efforts in this area are ongoing and hopefully some polymer-drug conjugates will be approved for clinical use very soon.

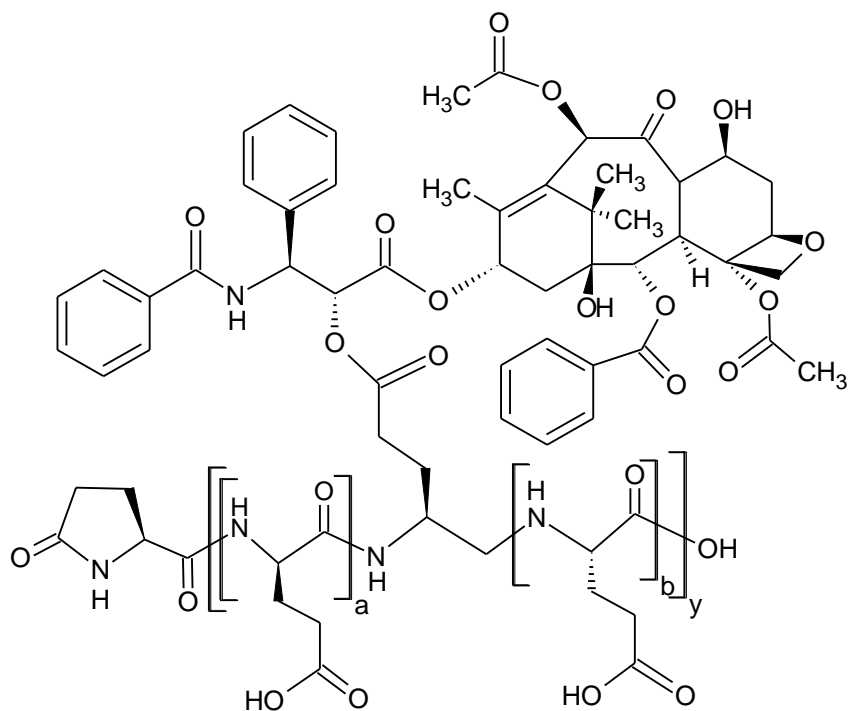

**Paclitaxel polyglumex (Opaxio<sup>®</sup>)**

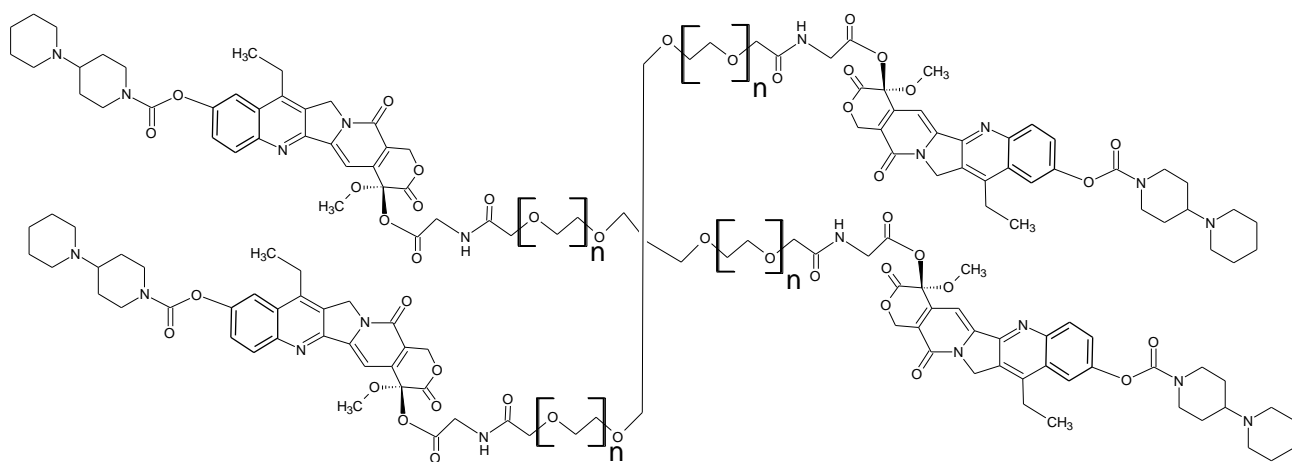

**Etirinotecan Pegol (NKTR-102)**

**Figure 2:** Chemical structure of A) PGA-paclitaxel conjugate (Opaxio<sup>®</sup>) and B) PEG-Irinotecan conjugate (Etirinotecan pegol<sup>®</sup>)

## 1.2 Polymeric nanoconjugates: innovative, not innocent drug delivery systems

Ideally, a drug delivery system (DDS) should deliver bioactive molecules to specific site at a specific time and in a specific pattern over a specific period of time however it is well documented that the conventional dosage forms have not met these criteria hence it has been a huge challenge to achieve effective delivery of drugs to the target site. Therefore there have been intensified research efforts to develop novel and innovative drug delivery systems that will provide controlled and site specific delivery of bioactive molecules. In this vein, both pharmaceutical and chemical approaches have been explored in drug delivery design. The pharmaceutical approaches include coating the active drugs with pH-sensitive polymers, biodegradable coatings, time-dependent delivery strategies and incorporation of drugs into therapeutic systems like liposomes and microspheres. On the other hand the chemical approach involves prodrug design in which a latent derivative of the drug is prepared, which is not active but is capable of delivering the active drug by chemical or enzymatic triggers. The use of macromolecules in prodrugs design as a strategy to achieve targeted drug delivery has attracted considerable interest in recent years including natural and synthetic polymers, polysaccharides, proteins, lipoproteins, peptides, lectins, antibodies *etc.* Other polymeric DDS developed include slow release of water soluble drugs, enhanced solubility and bioavailability of poorly soluble drugs, delivery of two or more drugs from the same formulation, controlled release of highly toxic drugs, targeted delivery systems *etc.* DDS are usually classified in terms of their structures and mechanisms of drug release. For instance in matrix based systems, the drug is dispersed in a polymeric matrix and its release is controlled by drug diffusion or matrix erosion. In hydrophilic matrices drug release is controlled either by matrix swelling or slow dissolution of the matrix while drug release from stimuli responsive systems is controlled by changes in stimuli such as pH or temperature. Membrane based systems involves dispersion of drug in the polymer membrane where drug release is controlled by diffusion or osmotic pressure.

Initially the main focus of formulation design was on constant or sustained release DDS in order to enhance patients' adherence especially in the treatment of chronic conditions. The versatile structure of polymers with potential opportunities for combined hydrophobic and hydrophilic characteristics as well as favourable polymer-polymer, polymer-drug and polymer-solvent interactions, provided suitable research platforms to design and prepare formulations with specific characteristics and functionalities (50-52). For example polymer-drug nanoconjugates (PDNs) are nanosized constructs which exhibit enhanced saturated solubility, high passive tumour-targeted drug delivery by the enhanced permeability and retention (EPR) effect and improved pharmacotherapy. The uniqueness of PDN includes surface modification of poorly soluble drugs as well as control of particle-size, particle size distribution, specific surface area and drug-loading efficiency which are crucial parameters that govern excellent clinical performance of poorly soluble drugs including anticancer agents. Some examples of the particles size and drug-loading efficiency of anticancer PDNs reported in literature are presented in Table 1. This phenomenon provides a platform for developing both new and existing polymeric materials and their combinations as drug delivery tools for effective delivery of poorly soluble drugs. Some examples of patents for nanoconjugates are presented in Table 2. In this regard, rational design of polymer-drug nanoconjugates is vital to achieving the true potentials of polymer therapeutics including enhanced clinical success and regulatory approval.

One area of polymer-drug formulation design that has received less attention is the influence of potential pharmacological action of some polymers on the overall therapeutic effects of the active drug molecule. Most natural and synthetic biocompatible biomaterials used as drug carriers are thought to be *inactive* with no other role than delivering the active molecule to the target site of action. However many studies have demonstrated that some natural polymers such as chitosan exhibit remarkable pharmacological activity and may contribute significantly to the overall therapeutic effects of the active molecule. For instance, Bajaj *et al.*, 2012 reported the unique ability of chitosan derivative to suppress endotoxin-mediated pro-inflammatory cytokine production in macrophages (53). Chitosan (cationic polymer) has also been reported to exhibit hemostatic activity due to its ability to interact with the anionic cell membrane of the red blood cells resulting in platelet activation and clot formation (54). It promotes wound healing process (55) and shows bacteriostatic activity against broad spectrum of microorganisms (56). Since these activities were not anticipated during the formulation design, the effects are most often ignored in data analysis which may lead to overestimation of the delivery capacity of the biomaterial and/or erroneous prediction of the clinical value of the active drug. It goes without saying that these innovative drug nanocarrier systems may not be innocent afterall. Therefore understanding the implications of these additional effects in drug product development would be of great value.

**Table 1:** Examples of particle size and loading efficiency of polymer-drug nanoconjugates

<i>Drug</i>	<i>Copolymer used</i>	<i>Average size (nm)</i>	<i>Loading Efficiency (%)</i>	<i>Reference</i>
<b>Paclitaxel</b>	mPEG-PLLA-PMMD	70 – 90	14.3	(57)
	mPEG-PCL-poly( $\epsilon$ -caprolactone)	< 150	39.58	(58)
	PCL-PEG-PCL	20.5	4.8	(59)
<b>Doxorubicin</b>	PLGA-PEG	61.48	99.09	(60)
	PEG-PLLA	188.43		(61)
	PEG-PBLA	50 – 70	50 - 60	(62)
	PEG-polycaprolactone	20	56.7	(63)
	PEO-poly(ethylene oxide)-PBLA	20 – 30	65	(64)

*PEG – polyethylene glycol; mPEG – methoxy PEG; PLLA – poly(L-lactic acid); PMMD – poly(3(S)-methyl morpholine-2,5-dione); PCL – poly( $\epsilon$ -caprolactone); PLGA – poly(DL-lactic-co-glycolic acid); PLLA - poly(L-lactic acid); PBLA – poly( $\beta$ -benzyl-L-aspartate); PEO – polyethylene oxide*

**Table 2:** Examples of patents for polymer-drug nanoconjugates

<i>Patent</i>	<i>Publication No.</i>	<i>Publication Year</i>	<i>Inventors</i>	<i>Reference</i>
Nanoconjugates and nanoconjugate formulations	WO2011079279A3	2011	Cheng and Tong	(65)
Small molecules ligand-drug conjugates for targeted cancer therapy	US20110085974A1	2011	Leland <i>et al.</i>	(66)
Nanoconjugates able to cross the blood-brain barrier	US20150031745A1	2015	Mirkin <i>et al.</i>	(67)
Polymalic acid based nanoconjugates for imaging	EP2694117A1	2014	Black <i>et al.</i>	(68)
Therapeutic Nanoconjugates	WO2009038776A1	2009	Manneh	(69)
Aptamer-coated paclitaxel-poly lactide nanoconjugates: Formulation and cancer targeting	WO PCT/US2010/062030	2010	Cheng and Tong	(70)



## 2.0 Rational design of nanoconjugate formulations

Rational design of polymer-drug nanoconjugates was based on the model proposed in 1975 by Helmut Ringsdorf for the delivery of anticancer drugs (35) consisting mainly of five components including a natural or synthetic polymeric carrier, low molecular weight hydrophobic bioactive molecule(s), a bioresponsive spacer, targeting group and a solubilizing group (Fig 3). The polymer carrier should ideally be water-soluble, biocompatible (non-toxic and non-immunogenic) and biodegradable as well as exhibiting suitable functional groups for the attachment of drug or spacer respectively. If non-biodegradable polymer is used, its size must be lower than the renal threshold to ensure excretion in order to prevent undesirable accumulation in the body. Soluble polymers with molecular weight below 50,000 Da can be excreted through the glomerular kidney filtration providing evidence for their biocompatibility. However selection of suitable polymer(s) and a robust conjugation technique are very critical steps in successful polymer-drug nanoconjugate design (71,72). In the same vein polymers with maximum molecular weights that are within the renal excretion threshold should be considered because polymers exhibit different conformations and levels of hydration in aqueous solutions depending on their size and molecular weights (73). It was envisioned that the pharmacologic properties of a PDN model could be manipulated by changing the physical and chemical properties of the polymer such as molecular weights, coil structure, steric effects, copolymer composition, polyelectrolyte charges, flexibility of polymer chain *etc.* This would provide a template for the design of various PDNs with specific applications. For example, introduction of solubilizing groups (e.g. pyrrolidone or acrylamides) into the polymer chain provides non-toxic and non-immunogenic characteristics as well as increasing the solubility of poorly soluble drugs thereby improving its bioavailability and therapeutic effects. Fast or slow drug release rate can be modulated by placing a bioresponsive spacer group between the drug and the polymer chain especially in polymer-enzyme conjugates where direct fixation of enzymes to the polymer chain can lead to loss of enzymatic activity (74,75). The widely used hydrolysable or biodegradable chemical links between the polymer and bioactive molecule (e.g. ester, orthoester, peptidyl, amide, carbonate, anhydride and urethane) must be sufficiently mild to ensure effective conjugation and efficient drug release without any adverse effect on its biological activity. It must also allow controlled release of the active drug from the nanoconjugate at the site of pharmacological action. The linkers should be degraded by a physiological trigger (e.g. change in pH, presence of enzyme such as esterases, lipases or proteases) in the intracellular compartment in order to release the drug at the site of pharmacological action. On the other hand the linkers should be stable in the blood stream to prevent premature drug release (76). Degradability of the polymer has been associated with the type of drug conjugated to the polymer. For example when the peptidyl linker, Glycine-Glycine (GG) was used for the delivery of HPMA copolymer-Doxorubicin conjugates, it was non-biodegradable (77). However when the same linker was used with HPMA copolymer-Mephalan conjugate it was biodegradable (78). The first polymer-drug conjugate to undergo clinical evaluation was Dextran-doxorubicin conjugate (AD-70, DOX-OXD) (79). The authors conjugated oxidized dextran (70,000 g/mol) with doxorubicin to form a Schiff base which was tested in patient volunteers. The trial was discontinued due to high liver toxicity at maximum tolerable dose of 40 mg/m<sup>2</sup> compared with free doxorubicin. A more successful clinical trial was observed with the synthetic copolymer N-(2-hydroxypropyl) methacrylamide (HPMA). HPMA copolymer-Doxorubicin conjugate (PK1, FCE28068) was prepared by binding doxorubicin to the carboxy terminus of the degradable tetrapeptidic linker through an amide bond with drug loading efficiency of 8.5%. In a phase I clinical trial on 36 patient volunteers diagnosed with non-small cell lung cancer (NSCLC), colorectal cancer, and anthracycline-resistant breast cancer, only two partial and two minor responses were observed at a dose of 80 mg/m<sup>2</sup> doxorubicin equivalent. The success was based on the fact that the typical side effects of anthracyclines such as congestive heart failure were not observed providing the rationale for further clinical trials of the conjugate. It was evident in literature that polymer-drug conjugation improves the pharmacokinetic profile of poorly soluble drug at the cellular level (8); increases plasma half-life and volume of distribution; reduces renal and hepatic clearance; protects the drug against premature degradation and introduction of a targeting group provides transport to site of action could boost the therapeutic index of the conjugate (80-82).

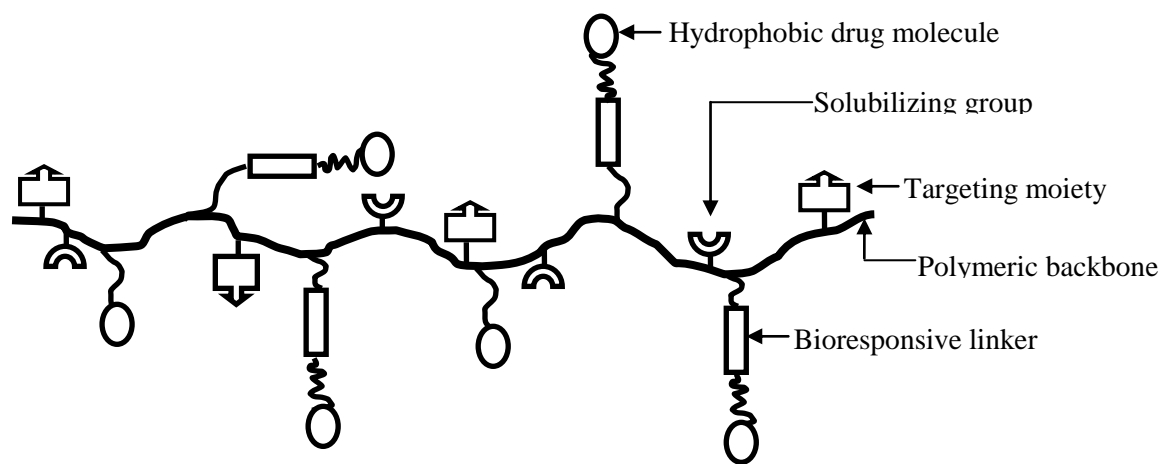

**Figure 3:** Representation of the components of polymer-drug conjugates.

## 2.1 Tumour targeted polymer-drug nanoconjugates

The initial focus of PDC design was on the delivery of anticancer agents because they are often limited by poor water solubility, metabolic instability and relatively low therapeutic index due to dose-dependent toxicity as well as the complexity and severity of cancer progression. Polymeric nanocarriers have been utilized to increase therapeutic efficacy of anticancer agents by nanotargeted delivery (passive or active targeting) where more drug molecules are available at the target site while systemic drug exposure is reduced (26). In corollary the main goal of anticancer therapy is to deliver a dose high enough to achieve cytotoxicity within the tumour tissues without any significant toxicity to other vital organs emphasizing the need for targeted drug delivery strategy. On the other hand the cascade of pathogenesis of cancer is complex due to the ability of tumour to progress from a non-angiogenic to angiogenic phenotype (angiogenic switch). They only become clinically detectable after a sufficient tumour mass expansion which is dependent on increased expression of positive (pro-) angiogenic regulators secreted by the tumour cells such as vascular endothelial growth factor (VEGF), basic fibroblast growth factor (bFGF), transforming growth factor beta (TGF- $\beta$ ) and platelet derived growth factor (PDGF), and decreased expression of negative angiogenic regulators such as thrombospondin-1, endostatin and angiostatin as well as angiogenic balance within the tumour cells (83-85). Therefore the focus of treatment involves prevention of vascular endothelial cells from responding to the range of pro-angiogenic molecules secreted by the tumour cells (direct angiogenesis inhibitors e.g. endostatin, vitaxin, angiostatin, and tumstatin) and blocking the activity of pro-angiogenic factors or their receptors by indirect angiogenesis inhibitors such as gefitinib (Iressa<sup>®</sup>), trastuzumab (Herceptin<sup>®</sup>) and bevacizumab (Avastin<sup>®</sup>). However tumour cells possess intrinsic propensity to develop acquired drug resistance due to their genomic instability in addition to the poor biopharmaceutical properties of anticancer drugs. These phenomena explain the complications involved in delivering active drugs to the tumour cells providing potential research opportunities in tunable therapeutic intervention and targeted delivery systems. For example conventional anticancer therapy is transported through the blood circulation to all tumour cells which are distant in tumour tissues where they are less accessible to the chemotherapy drugs (Fig. 4). Therefore there is need for advanced anticancer drug formulations designed to target tumour cells as well as tumour-associated endothelial cells and tumour microvessels which have distinctive phenotypic and functional characteristics that are easy targets for selectively designed formulations. One strategy is to combine anti-angiogenic agent with anti-cancer agent to provide synergistic inhibitory effect. Fixed dose combination of therapeutic agents with different biochemical targets has attracted great research interest in the recent past especially for cancer treatment in order to improve their therapeutic effectiveness in terms of enhanced efficacy and reduced toxicity as discussed above.

Anti-angiogenic formulations could be administered more frequently at low doses (metronomic schedule) to prevent the undesirable toxicity and side effects such as bone marrow suppression, hypersensitivity reactions, anaphylaxis, pulmonary toxicity, gastrointestinal disturbances and secondary malignancy which are associated with the maximum tolerable dose (MTD) of the anticancer drugs (86). Presently most of the angiogenesis inhibitors are poorly water soluble drugs with low therapeutic index and are delivered through systemic routes in organic and toxic solvents therefore biodistribution and pharmacokinetics profiles are non-specific. Also the chemical instability and short half-life of this class of drugs may reduce their resident time in the tumour cells as

well as their therapeutic effectiveness. It is apparent that formulating these drugs as polymeric nanomedicines with target-specific recognition moiety to selectively target the metabolically active endothelium that support tumour growth and the tumour cells as well as the site-specific release of the anticancer agents will offer accumulation in the tumour vasculature; longer systemic circulation time; improved bioavailability; chemical stability and improved therapeutic index with minimized systemic toxicity. It is therefore apparent that PDNs with a wide variety of structural architecture and chemical properties could be developed to unlock and harness the potentials of these nanoconjugates for fit-for-purpose design of more sophisticated advanced polymeric nanomedicines. A combination of increasing understanding of the molecular mechanisms of tumour pathogenesis and emerging technological advancements has provided insights into new molecular targets and opportunity to design more effective polymer-drug nanoconjugates. Examples of polymer therapeutics targeted to tumour angiogenesis are presented in Table 3.

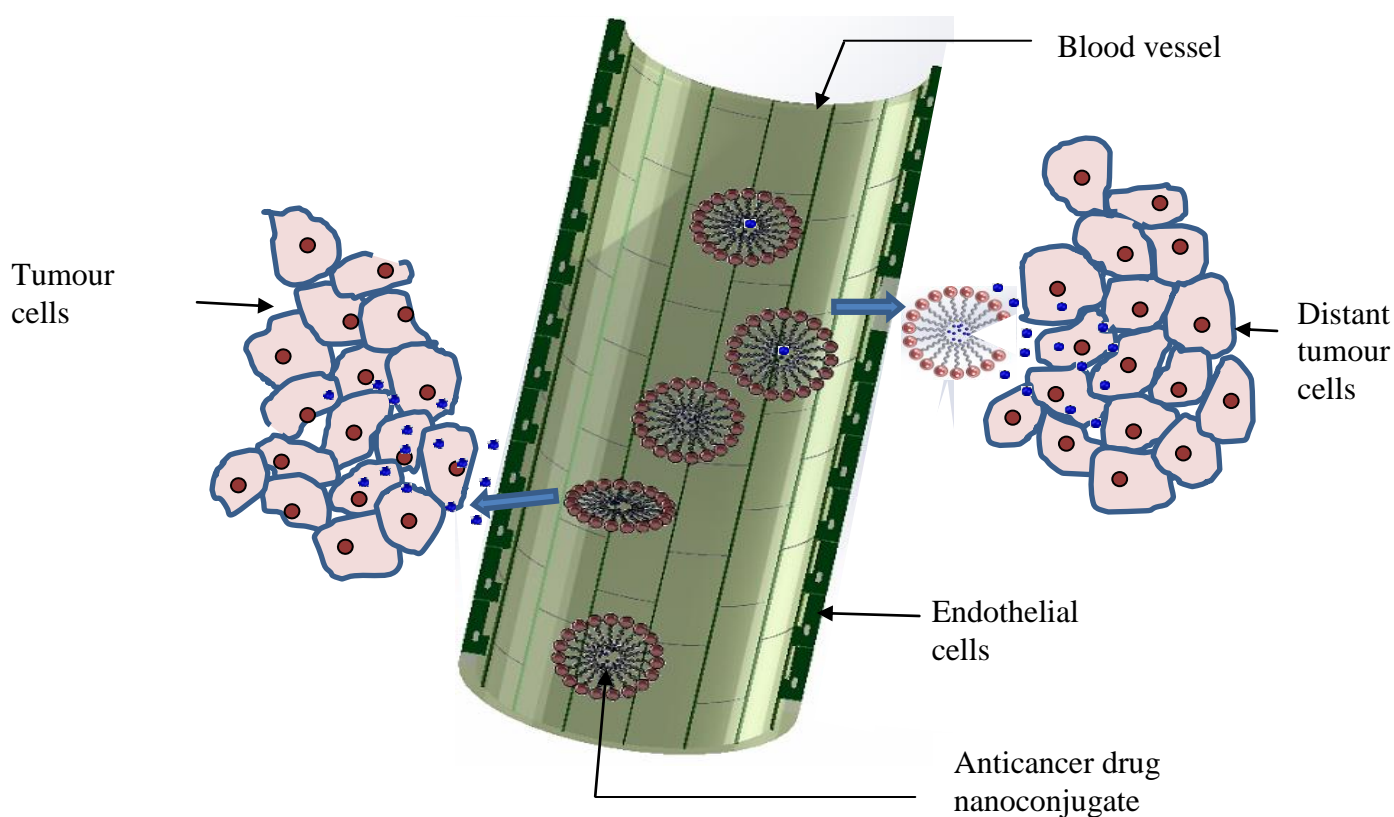

**Figure 4:** Illustration of transportation of anticancer therapy through blood circulation

**Table 3:** Examples of tumour targeted polymer-drug conjugates

<i>Drug</i>	<i>Polymer-drug conjugate</i>	<i>Linker</i>	<i>Target</i>	<i>Reference</i>
<b>Camptothecin</b>	HPMA copolymer-camptothecin (MAG-CPT)	Ester	DNA topoisomerase I	(87,88)
	PGA-camptothecin (CT-2106)	Amide	DNA topoisomerase I	(89)
	PEG-camptothecin (pegamothecan)	Ester	DNA topoisomerase I	(90,91)
	Carboxymethyl dextran-exatecam (IDF 310)	Amide	DNA topoisomerase I	(92)
	Cyclodextrin-camptothecin (IT-101)	Amide	DNA topoisomerase I	(93,94)
<b>Curcumin</b>	PEG-curcumin	Ester	Jun activation domain binding 1 (Jab1)	(95)
<b>Wortmannin</b>	HPMA copolymer-WTN	Ester	Phosphoinositide 3-kinase	(96)
<b>Doxorubicin</b>	Oxidized dextran-Dox (AD-70)	Schiff base	Reactive Oxygen Species; DNA alkylating	(79)
	HPMA copolymer-Dox (PK1, FCE28068)	Peptidyl linker	Aromatase inhibitor; DNA alkylating	(8,97)
	HEMA copolymer-Dox-galactosamine(PK2, FCE 28069)	Peptidyl linker	Aromatase inhibitor; DNA alkylating	(81)
<b>Paclitaxel</b>	HPMA copolymer-paclitaxel (PNU 166945)	Ester	Angiogenesis inhibitor	(72)
	PGA-paclitaxel	Ester	Angiogenesis inhibitor	(98)

### 2.1.1 Passive targeting

Tumour-specific targeting is usually achieved by PDNs through enhanced permeability and retention (EPR) effect due to the unique pathophysiological characteristics of the solid tumour including

- i) vascular abnormality such as leaky blood vessels which is likely to allow preferential extravasation of circulating macromolecules and
- ii) lack of effective intratumoural lymphatic drainage which can lead to polymer retention and passive accumulation of macromolecules and nanosized particles in the tumour tissues.

This phenomenon has led to increased uptake, accumulation and retention of macromolecules by solid tumours up to 100-folds compared to free drug with the prospect of increasing the therapeutic index due to lack of intratumoural lymphatic clearance. In contrast, the low molecular weight active drug diffuses rapidly and indiscriminately into both normal and tumour cells through the systemic circulation thereby causing undesirable side effects and fast renal clearance (11,12,99,100). Size of the polymer carrier is an important parameter when designing polymer-drug conjugate because of its influence on the extent of accumulation in the tumour cells and the pharmacokinetic profile of the active drug. For example the normal renal threshold is between 30 and 50 kDa therefore polymers with molecular weight range of 20 to 200 kDa are often used (101). Although the optimum size of the polymer-drug nanoconjugate required for effective accumulation in the tumour by EPR

effect is not yet known, direct observation of the tumor vasculature has demonstrated a tumor-dependent cut off size of 200 nm – 2  $\mu$ m (102,103) while nanoparticle-dependent studies indicated cut off size of 200 nm – 1.2  $\mu$ m (104). In the same vein polymer nanoconjugates with molecular diameter 5 – 20 nm has been reported to exhibit excellent intratumoural penetration (uptake) comparable to liposomes and nanoparticles (105). It is well documented that polymer-drug nanoconjugates can increase the therapeutic index of anticancer agents through enhanced permeability and retention (EPR) effect (99,100,106-109). Other factors influencing the biodistribution of macromolecules include charge density, conformation, hydrophobicity and immunogenicity of the polymer.

### 2.1.2 Active targeting

The active targeting approach requires incorporation of target-specific recognition moiety (e.g. antibodies, antibody fragments, oligosaccharides, hormones, growth factors, ligands, peptides or other small molecules) into polymer-drug conjugate to provide selective localization at the target site for effective delivery of the bioactive drug. The linker and targeting group must possess appropriate functionality to facilitate effective conjugation to ensure its stability in the blood circulation. The major advantage of this phenomenon is the physical delivery of the PDNs directly to the target cells ensuring they remain at their intended site of action. For example, antibodies provide excellent binding affinity and greater target selectivity than other targeting moieties such as oligosaccharides and peptides. However they have a large size which can have significant effect on their targeting properties. In this case receptor-active antibody fragments such as recombinant single-chain variable fragments (ScFv) have been utilized to generate numerous vascular target-specific antibodies which have been successfully adapted in cancer chemotherapy. The ScFv, often produced in bacterial cultures, have reduced size but they still retain the specificity of the antibody. In most cases the antibodies or antibody fragments were directly conjugated to the bioactive drug molecule, not as targeting group on the polymer-drug conjugate (35,110,111). Overall, the selection of appropriate targeting moiety is underpinned by the specificity, affinity and binding efficiency of the targeting group as well as a balance between the binding efficiency and drug release. It would be interesting to investigate the impact of the conjugation process on the specificity and binding capacity of the targeting group.

An ideal target in a diseased tissue should overexpress unique identifiable cell surface markers compared to the normal cells in order to increase the probability of drug binding, cellular uptake and therapeutic effects of the nanoconjugates. Several studies have shown that vascular targeted polymer-drug conjugate integrated with active homing ligands exhibited strong and selective adhesion to the microvasculature providing a selective delivery of high concentration of anticancer agent. For example HPMA copolymers containing cyclic Arg-Gly-Asp peptides have been developed for targeting  $\alpha$ v $\beta$ 3 integrins expressed on angiogenic tumor blood vessels and other tumor cells. The anticancer and antiangiogenic agent, geldanamycin (aminohexylgeldanamycin), was conjugated to the polymer backbone through a lysosome-degradable GFLG (Gly-Phe-Leu-Gly) linker and the molecular weight was maintained at 40 kDa to ensure renal clearance after administration (112-116). The authors reported significantly higher localization of drug-loaded HPMA copolymer containing the arginylglycylaspartic acid (RGD) peptide (target moiety) in tumour cells and tumour growth suppression in prostate cancer bearing mice compared to control without a targeting moiety. They demonstrated that careful selection of targeting group can enhance the delivery and efficacy of cancer chemotherapy. In similar studies peptides that can specifically recognize and selectively bind to tumour vasculature with high affinity have been screened for delivery of cytotoxic compounds such as doxorubicin (117) and proapoptotic peptides (118). From the foregoing it is apparent that both passive and active tumour-targeted polymer-drug conjugates have enormous potential for cancer therapy as they improve therapeutic index of the angiogenic agents by increasing their half-life, their water solubility and exposure time to the tumour endothelial cells while toxicity is reduced (119). Initially most research efforts were focused on receptor-mediated drug targeting and polymer-drug conjugates bearing tumour-specific ligands including antibodies, peptides and saccharides were developed to improve selectivity of anticancer agents (19,24). However there is substantial literature evidence that even in the absence of the ligands PDC exhibits prolongs blood circulation time and promotes passive tumour targeting by reducing the particle size to nanometer range and the enhanced permeability and retention (EPR) effect which play a significant role in delivering anticancer drugs directly to the tumour site.

## 2.2 Polymer-drug nanoconjugates targeting other diseases

The novel therapeutic applications of PDNs have been extended to many drugs in various human pathologies apart from anti-cancer drugs, especially poorly soluble drugs with low therapeutic index, high toxicity, inconsistent pharmacokinetic profile and poor bioavailability. For example phloridzin (PRZ), a competitive inhibitor of sodium-glucose cotransporters (SGLT1 in the intestine and SGLT2 in the kidney), is an effective antidiabetes drug. However when taken orally phloridzin is almost entirely converted into phloretin by hydrolytic enzymes in the small intestine, therefore it is not used orally. Ikumi *et al.* prepared  $\gamma$ -PGA-PRZ nanoconjugate using a nonbiodegradable linker, which protected the drug from enzymatic hydrolysis. They reported significant suppression of glucose-induced hyperglycaemia and there was no significant changes in the free PRZ after oral administration of the nanoconjugate (120). Peptoids (N-substituted glycine), an endotoxin neutralizer have potent antimicrobial activity and is completely resistant to proteolysis. However its poor water solubility and nonspecific toxicity have limited its use in systemic treatment of sepsis. Vicent *et al.* demonstrated that PEG-peptoid 7 (PTD7) nanoconjugate containing diglycil spacer (PEG-2G-PTD7) showed significantly enhanced solubility and remarkable decrease in toxicity in the macrophages. The nanoconjugates also induced significant improvement from sepsis in the murine model, compared with the free drug. The authors suggested that nanoconjugate-based endotoxin neutralizers decreased plasma levels of proinflammatory cytokines and may provide novel approaches to treatment of sepsis (121). Other applications of polymer-drug nanoconjugates include rheumatoid arthritis (122), inflammation (123), regenerative medicine e.g. for wound healing (124), ischemia (125) and osteoporosis (126) *etc.*

## 2.3 Types of polymer-drug conjugates

The location of the reactive groups on the polymer chain to which the drug is covalently attached determines the type of polymer-drug conjugate that will be produced. These reactive groups could be located at the end of the polymer chain or at pendant positions forming the 'end group' and 'pendant group' systems respectively (71). In the end group systems conjugation can occur at either or both extreme ends of the polymer chain whereas in the pendant group system the number of pendant reactive groups on the polymer chain can be controlled to accommodate same or different bioactive drugs by using biodegradable spacers (Fig 5). Polyethylene glycol (PEG) is the most widely used polymer in the synthesis of end group polymer-drug conjugates because of its simple structure, easily activated for conjugation, controlled permeability potentials, non-toxicity, reduced immunogenicity and antigenicity, resistance to surface adsorption, enhanced solubility and stability, inexpensive as well as prolonged circulation time. It is very popular in protein PEGylation where lysine-, histidine- or cysteine- amino group of the bioactive protein is conjugated to PEG by replacing the hydroxyl end group (127). For instance PEGylation of bovine adenosine deaminase via amide bond (Adagen<sup>®</sup>) was approved by FDA in 1990 and commercialized by Enzon Pharmaceuticals Inc for the treatment of severe immunodeficiency diseases with 6.4 times blood circulation time than the unmodified protein (128).

Other examples of PEG- protein conjugation include PEG-L-asparaginase conjugate (Oncaspar<sup>®</sup>) approved in 1994 for the treatment patients with acute lymphoblastic leukaemia exhibiting lower immunogenicity than the native protein. PEG- $\alpha$ -interferon ( $\alpha$ -IFN) conjugate (PEG-INTRON<sup>®</sup>) approved in 2000 for the treatment of hepatitis exhibited plasma circulation time of 8 times greater than the native IFN protein. PEGylation with peptides, oligodeoxynucleotides, antibody and antibody fragments and anticancer drugs have also been reported with enhanced pharmacokinetics, superior uptake, longer blood circulating time and increased solubility of the unmodified drug respectively (127,129-133).

The pendant group systems consist of different types of polymers which may contain single reactive pendant group or specifically synthesized to control the number of reactive pendant groups along the polymer chain. For instance the drug will firstly be chemically linked to an acrylic group through an ester or amide bond followed by copolymerization of the monomer-drug complex with other hydrophilic acrylic monomers such as acrylic acid, vinyl pyrrolidone, 2-hydroxyethyl methacrylate or dimethyl acrylamide providing a controlled hydrophobic-hydrophilic balance (HLB). This balance underpins the stability of the conjugate, copolymer swelling and drug diffusion through the polymer matrix. Biodegradable spacers may also be incorporated between the drug and the copolymer backbone to prevent premature hydrolysis of the conjugate. The number pendant reactive groups may be controlled by preparing alternating copolymers to provide repeating units of the reactive groups along the copolymer chain allowing different types of bioactive molecules to be linked to the same copolymer chain. For example HPMA copolymers have been used widely to prepare water soluble pendant group conjugated systems for the delivery of anticancer agents such as doxorubicin which has ben

clinically tested, paclitaxel and camptothecin (8). Biodegradable peptide linker (Gly-Phe-Leu-Gly) was included in the conjugate design to ensure stability of the conjugate within the systemic circulation as well as premature release of the drug after cellular uptake. Because HPMA is non-degradable, the low molecular weight (MW 30,000 Da) was chosen to ensure renal elimination of the copolymer and tumour-targeting effect was achieved through enhanced drug permeability and retention (EPR) phenomenon (134,135). Maeda *et al.* developed SMANCS a conjugate of poly(styrene-co-maleic acid/anhydride) (SMA) and neocarzinostatin (NCS) an antitumour protein covalently bonded by amide group for the treatment of hepatocellular carcinoma (136). NCS on its own exhibits very short plasma half-life and very toxic causing bone marrow suppression. However SMANCS conjugate exhibited hydrophobic characteristics with higher accumulation in the tumour tissue than normal tissue as well as reduced immunological reactions. The tumour-targeted and hydrophobic characteristics of SMANCS have been utilized in the formulation of highly stable oily preparations (e.g. SMANCS/Lipidol) for anticancer drug delivery through tumour-feeding arteries which has been shown to be one of the most efficient targeting strategies for this type of formulations (137,138). Research efforts in polymer-drug conjugate design with pendant groups of acrylic derivatives has been extended to other bioactive molecules including analgesics (paracetamol and salicylic acid) (139), anti-thrombogenic agents (Triflusal) (140), non-steroidal anti-inflammatory agents (ketoprofen and ibuprofen) (141), vitamin E (142).

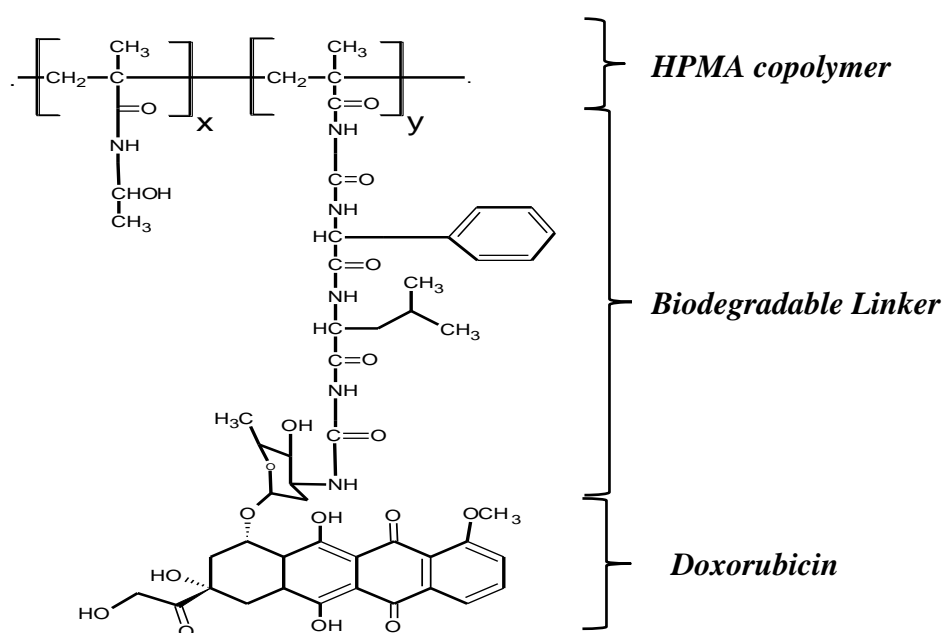

#### End group system

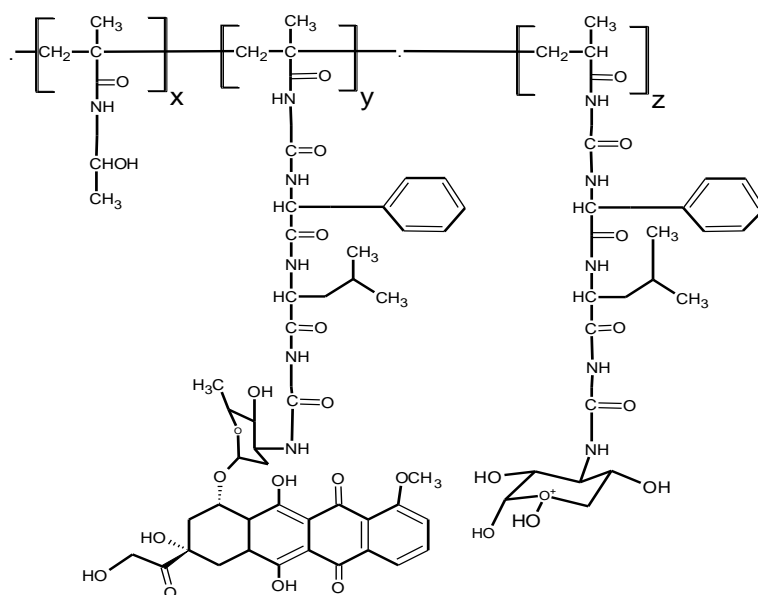

#### Pendant system

**Figure 5:** Typical end-group and pendant polymer-drug conjugate based on HPMA copolymer modifications.

### 2.3.1 Multiple drug-polymer conjugates for cancer treatment

Most drug delivery systems including polymer-drug conjugates are used for the delivery of single bioactive agent however the increasing complexity of chronic disease conditions and evolution of multiple drug resistance render single drug therapy less effective especially in chronic conditions such as cancer and antibiotic resistance. Therefore combinations bioactive agents are being explored to co-transport required drugs to the target site of action in order improve therapeutic outcome. However, in order to optimize the advantages of fixed dose combination therapy, it is important to combine bioactive agents with independent mechanisms of action and different cellular targets to provide synergistic or additive therapeutic effects as well as reducing potential side effects and drug resistance. Detailed review of the prospects of polymer-drug conjugates in combination therapy has been presented by Greco and Vicent (143). The authors identified four distinct formulation strategies for the polymer-based combination therapy including polymer-drug conjugate plus free drug (S1); polymer-drug conjugate plus polymer-drug conjugate (S2); single polymer carrying a combination of two or more drugs (S3) and polymer-directed enzyme prodrug therapy (PDEPT) (S4). It was noted that only S1 has been clinically explored and S3 was favoured because of their ability to simultaneously deliver multiple drugs to the same site of action and the potential synergistic drug effects. Example of such multiple drug-polymer conjugate is presented in Fig. 6.

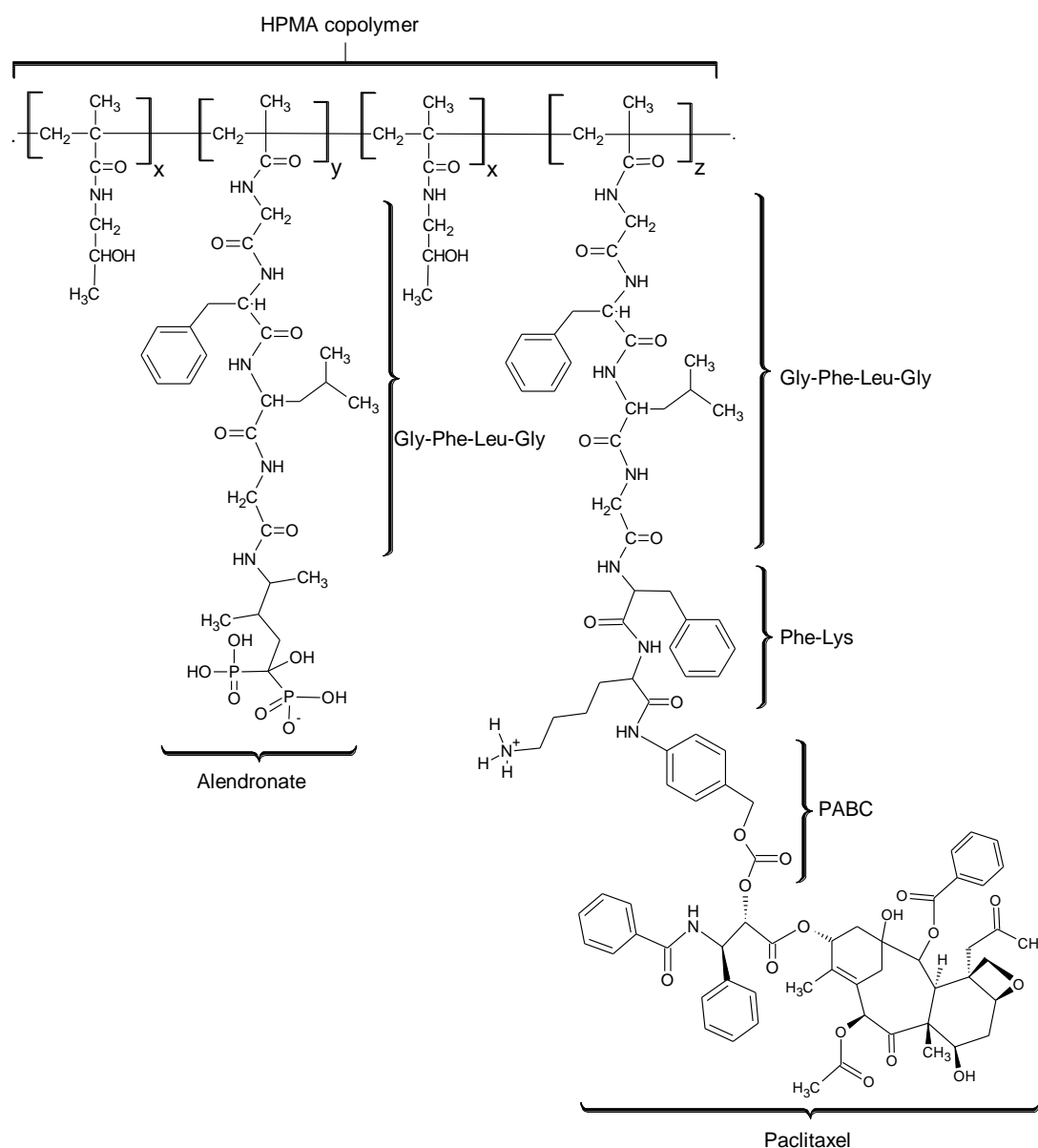

**Figure 6:** Example of multiple drug-polymer conjugate with multiple spacers for cancer treatment



Administration of combination of anticancer drugs with different biological targets can improve therapeutic index by enhancing therapeutic effectiveness and reducing toxicity. This phenomenon has been explored to provide remarkable improvement of therapeutic outcome in the treatment of childhood leukaemia and Hodgkin's disease (143). For example doxorubicin (DNA intercalator) was combined with ara-C (DNA polymerase inhibitor) in the treatment of acute nonlymphocytic leukaemia in order to inhibit DNA synthesis and repairs. In the same vein administration of leucovorin prior to 5-fluorouracil (5-FU) in colorectal cancer has been reported to enhance the affinity and binding of 5-FU to thymidylate synthetase thereby blocking its action. Other drug combinations for cancer therapy include adriamycin and cyclophosphamide; cyclophosphamide, adriamycin and 5-FU; cyclophosphamide, methotrexate and 5-FU; cyclophosphamide, methotrexate, 5-FU, vincristine and prednisone; paclitaxel and carboplatin for ovary and lung cancer; paclitaxel, carboplatin and vinorelbine for non small cell lung cancer *etc.* The ability to tailor different combinations of poorly soluble drugs as well as their drug loading efficiency in the polymer conjugate provides a platform for synergistic and bi-specific effects especially in anticancer therapy. The synergy phenomenon allows administration of lower concentrations of each agent, with increased efficacy and decreased toxicity. They also offer controlled rate, extent and duration of drug delivery over a well-defined time interval, providing a platform for custom design of nanomedicines to achieve the desired therapeutically effective plasma concentration and avoid large fluctuations associated with large and multiple dosing which can lead to undesirable side effects, organ damage, or toxicity.

## 2.4 Selection of suitable polymers

Selection of a suitable polymer and a targeting moiety is essential for the effectiveness of the PDNs. Many polymers have been investigated as potential candidates for drug delivery however it is important that the ideal polymer is inherently biodegradable, non-toxic and non-immunogenic. It should exhibit low poly dispersity (high homogeneity) with one reactive group for protein conjugation to avoid crosslinking and many reactive groups for small active molecules to achieve appropriate drug loading (conjugation efficiency) and longer residence time for prolonged action or to allow effective drug distribution. When non-biodegradable polymers are used, those with sufficiently low molecular weight (less than 30 – 40 kDa) should be considered to allow renal elimination preventing polymer accumulation in the body. The most commonly used polymers in PDN design include natural polymers [chitosan, dextran, dextrin, pullulan, mannan, proteins, hyaluronic acid]; synthetic polymers [N-(2-hydroxypropyl)methacrylamide (HPMA) copolymer, poly(ethyleneimine) (PEI), poly(acrololmorpholine) (PACM), poly(vinylpyrrolidone) (PVP), polyamidoamines, divinylmaleic anhydride/acid (DIVEMA) copolymer, poly(styrene-co-maleic acid/anhydride (SMA), polyvinyl alcohol (PVA)] and pseudosynthetic polymers [polyglutamic acid (PGA), poly(L-lysine), poly(malic acid), poly(aspartamides), poly((N-hydroxyethyl)-L-glutamine) (PHEG)] (144-149).

### 2.4.1 Natural polysaccharides

#### *Chitosan*

Chitosan (CT) is a unique cationic aminopolysaccharide containing randomly distributed  $\beta$ -1,4-linked glucosamine and N-acetyl-D-glucosamine units. It is prepared by N-deacetylation of chitin, a natural polysaccharide found in the exoskeleton of insects, shrimps, crabs and lobsters as well as fungi (150). CT has attracted increasing research attention due to its abundant availability, low production cost, nontoxicity, biocompatibility, biodegradability (through hydrolytic degradation by enzymes e.g. lipase, lysozyme, amylase), ability to form nanoparticles and hydrogels, ability to enhance drug penetration through mucosal tissues by opening tight junctions as well as its bioadhesive properties and inherent pharmacological properties (150). Chitosan is soluble in acidic pH where its amine groups are protonated to produce reactive cationic functional group (protonated amine D-glucosamine monomeric unit) which provides unique features such as pH-dependent solubility, complexation with anionic macromolecules such as proteins and nucleic acids as well as molecular interaction with small bioactive molecules. Chitosan has been used in the construction of several drug delivery systems including hydrogels, nanogels, nanoparticles, polyelectrolyte complexes (PEC) *etc.* PECs are formed spontaneously by mixing oppositely charged polyelectrolytes in solution without any chemical crosslinker due to high hydrogen bonding capacity and high affinity for oppositely charged molecules. For example we have reported the thermodynamic changes and surface modification induced by intermolecular interaction between the carboxylate ion of ibuprofen and the protonated amino group of chitosan (low energy green technique) (151). We demonstrated a remarkably amplified affinity between the chitosan and ibuprofen leading to formation of eutectic amorphous nanoparticle complex (nanoplex) which corresponded to higher saturated solubility and dissolution velocity dictated by chitosan concentration. Crystalline ibuprofen with rod-like shape

and particle size of  $453.88 \pm 29.8469 \times 97.12 \pm 5.4267 \mu\text{m}$  (aspect ratio  $5.16 \pm 1.15$ ) was converted into spherical amorphous nanoplex with particle size of  $14.96 \pm 1.162 - 143.17 \pm 17.5247 \text{ nm}$ . We also designed *ternary* chitosan-ibuprofen-gellan nanogel prepared by a combination of electrostatic nanoassembly and temperature-dependent ionic gelation techniques. Chitosan-gellan PEC exhibited a core-shell microcomplex structure with average particle size of  $48.61 \pm 18.899 \mu\text{m}$  ( $15.93 - 87.45 \mu\text{m}$ ) in which chitosan was the core and gellan the shell (Fig. 7). In that study the intermolecular interaction between ibuprofen and chitosan was amplified by controlled drug/polymer molar ratio, controlled solubility and charge screening to produce ibuprofen-chitosan nanoplex. The *ternary* nanogel exhibited enhanced skin penetration, permeability and rate of transdermal release of ibuprofen (152).

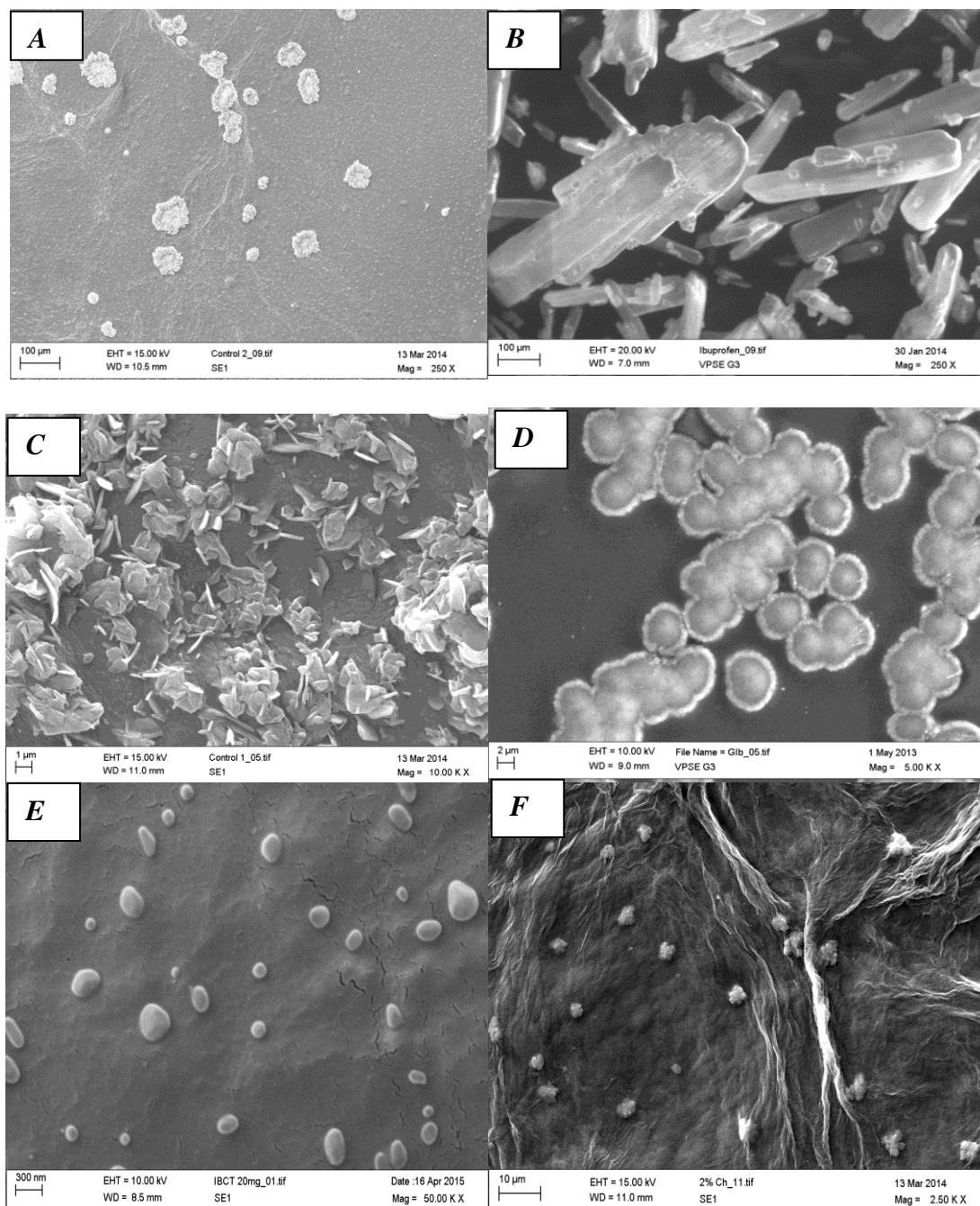

**Fig. 7:** Photomicrographs of polymer-ibuprofen conjugates A) chitosan-gellan polyelectrolyte complex; B) pure ibuprofen crystals; gellan-ibuprofen conjugates C) below and D) above critical conjugation concentrations; E) chitosan-ibuprofen conjugate; F) chitosan-ibuprofen-gellan conjugate

## **Dextran**

Native dextrans (MW  $10^7$  to  $10^8$ ) are naturally synthesized by a large number of bacteria including *Leuconostoc mesenteroids*, *Leuconostoc dextranicum* and *Streptobacterium dextranicum* belonging to the family *Lactobacillaceae*. Dextrans derived from *Leuconostoc mesenteroids* are of particular interest in pharmaceutical formulation because they contain 95%  $\alpha$ -1,6-glucopyranosidic linkages and 5% 1,3-linkages. Clinically useful dextrans are obtained by partial depolymerization of the native dextran by acid hydrolysis and fractionation. They are soluble in water, formamide, dimethylsulfoxide (DMSO) but insoluble in alcohol and acetone however their high polarity and high molecular weight limits their transcellular absorption across the bilipid biological membrane. Dextrans are usually very reactive, for instance they form alkoxide dextranate with alkali and alkaline earth metals and may be oxidized to form dextran derivatives.

Dextran can be attached to the bioactive drug to form a prodrug several techniques including direct linkage, attachment through intercalated spacer arm, use of modular ligand and tissue specific receptor ligand. In the direct linkage model the active drug would be released in a predictable manner. However the enzyme may not have access to the bulky dextran matrix due to their large molecular size therefore the regeneration of the parent drug molecule would be exclusively governed by the pH-dependent hydrolysis. Incorporation of spacer arm between the drug and the polymer carrier provides opportunity to vary the terminal functional group of the spacer arm in order to achieve the desired covalent bond. The spacer arm can also reduce the steric hindrance effect of the macromolecule thereby enhancing the accessibility of enzyme into the dextran matrix. On the other hand spacer can be used to protect enzyme-labile dextran prodrugs by customized construction that only allows pH-dependent hydrolysis to liberate the drug. Dextran-drug conjugates such as dextran esters, dextran ethers and dextran amides are reversible while dextran-enzyme conjugates, dextran-metal complexes and dextran-hormone complexes are irreversible. In any case, the active drug will be released from the dextran prodrug by cleavage of the covalent bond between drug and dextran (polymeric carrier) through hydrolysis or enzymatic action.

Literature is replete with application of dextran conjugates in site-specific drug delivery especially in colon-directed drug delivery. For example 5-Aminosalicylic acid (5-ASA) is an effective drug for the treatment of inflammatory bowel disease however it is rapidly absorbed in the stomach and small intestine so that only a negligible amount reaches the colon. This problem was overcome by preparing azo-coupled dextran-5-ASA conjugate prodrug which effectively delivered 5-ASA to the colon (153). In a similar study Lee *et al.* developed dextran-nalidixic acid (NA) ester as colon-specific prodrug. They demonstrated that nalidixic acid was not detected at pH 1.2 (HCl buffer), pH 6.8 (phosphate buffer) during a 6 h drug release study at 37°C however 41% of the drug was released when the prodrug was incubated with the cecal contents for 24 h at 37°C suggesting that dextran-NA may be chemically stable during its transit along the gastrointestinal tract and colon targeted delivery was evident (154). Methyl prednisolone was also covalently bonded to dextran using succinic acid and glutaric acid as the linkers and hydrolytic kinetic studies showed that the conjugation facilitated the delivery of the drug to large bowel (155).

The effectiveness of tumour targeting is underpinned by the extent of drug penetration into the tumour tissue and the rate of drug elimination from the tissue especially in brain tumour where the antitumour agent is introduced directly into the intracranial space. To verify this concept, Dang *et al.* synthesized methotrexate (MTX)-dextran conjugate by covalently linking MTX to dextran through a short-lived ester bond (MTX-ester-dextran) and a long lasting amide bond (MTX-amide-dextran). They reported that the cytotoxicity of the MTX-ester-dextran and MTX-amide-dextran were equivalent to unmodified MTX however the conjugation resulted in shifting of dose-response curve to a lower dose (156). Also, Ichinose *et al.* synthesized dicarboxymethyl dextran conjugate of cisplatin by immobilizing cisplatin to dextran polymer chain through six-membered chelating coordinate bond which exhibited remarkably longer half-life and better tumour inhibition activity than pure cisplatin in the colon (157). Charged dextran derivatives such as carboxymethyl dextran, dextran sulphate and diethylaminoethyl dextran can also form complexes with several small bioactive chemical entities due their huge numbers of hydroxyl groups available for complexation and can be extensively explored as drug carrier systems because they are biocompatible, biodegradable, non toxic, non immunogenic and non antigenic. For example the conjugate of paclitaxel with carboxymethyl dextran through amino acid linker exhibited better antitumour activity than paclitaxel alone (158). The more pronounced effects of cationic conjugates has been attributed to the presence of a high load of negatively charged sialic acid residues on cancer cell surface facilitating effective cationic conjugate absorption. In our laboratory we have investigated the impact of cationic diethylaminoethyl dextran (Ddex) on crystal behaviour and micromeritics properties of ibuprofen in ibuprofen-Ddex conjugate cristanules (159). We have also investigated the direct effect of ibuprofen-Ddex interaction on the solubility, dose distribution, dissolution velocity, pre-compression and compression characteristics of ibuprofen (160,161). Pure ibuprofen exhibited poor solubility, poor flow and compression characteristics due to its hydrophobic structure, rod-like shape, cohesive and viscoelastic properties. However we noted that Ddex

increased the solubility of ibuprofen by entropy-driven mechanism of solubilization which also translated into increased dissolution velocity and dissolution efficiency (complete release) within 168 h at low concentrations of Ddex compared with pure ibuprofen. Evaluation of the mechanism of densification during tapping and compression processes revealed that the presence of Ddex consistently improved primary and secondary particle rearrangement up to 7 folds compared with pure ibuprofen while deformation and fragmentation were limited significantly.

In a similar study we have utilized low energy 'green' technique to prepare electrostatic self-assembly of ibuprofen-Ddex nanoconjugates for extended release of ibuprofen. We demonstrated that a new eutectic product was formed from ibuprofen-Ddex intermolecular interaction producing spherical amorphous nanoconjugates with average particle size range of  $85.20 \pm 4.4461$  to  $157.10 \pm 10.0214$  nm which also translated into higher dissolution efficiency dictated by concentration of Ddex compared with pure ibuprofen (45).

### ***Cyclodextrins***

Cyclodextrins (CDs) are cyclic oligosaccharides containing six, seven or eight glucopyranose units corresponding to  $\alpha$ -,  $\beta$ - and  $\gamma$ -cyclodextrins respectively each containing  $\alpha$ -1,4-glycosidic linkages. They have a truncated cone structure with a hydrophilic exterior and hydrophobic interior providing a unique hollow cavity structure that can host small molecular weight hydrophobic drugs and facilitate their solubilization in aqueous medium to improve their bioavailability. This unique structure provides a platform for incorporating various bioactive molecules hence their utility values as drug delivery carriers (162). CDs and their derivatives are widely used as formulation excipients in more than 35 pharmaceutical products with well established monographs in official compendia including United States Pharmacopoeia and National Formulary as well as European Pharmacopoeia. When administered orally CDs are poorly absorbed from the gastrointestinal tract so they are generally considered safe in orally formulations. However parenteral injections of CDs have been reported to cause renal toxicity therefore only  $\alpha$ -CD is currently being used in parenteral formulations at very low concentrations (163). Toxicity of CDs has been linked to depletion of membrane lipids such as cholesterol. Cholesterol depletion could trigger alteration of several cell functions (membrane damage) such as cytoskeletal organization, compositions of cellular proteins and membrane fatty acids as well as cell morphology. A good correlation between solubilization capacity of CDs for cholesterol, their haemolytic activity and cytotoxicity has been reported (164) while literature reports on CD-induced apoptosis was not conclusive. Overall it would be important to take their effect on cell membrane into cognizance when designing CD-drug conjugates.

## **2.4.2 Synthetic polymers**

### ***Polyethylene glycol***

Polyethylene glycol (PEG) is synthesized by polymerization of ethylene oxide to produce methoxy-PEG or diol-PEG using methanol or water as initiator respectively. It is an attractive polymer for conjugation because of its unique quality attributes such as high solubility in water and various organic solvents, nontoxicity, non-immunogenicity and tunable polymer chain. It has been widely used in the synthesis of polymer-protein conjugates because of its ability to protect protein against enzymatic degradation by steric hindrance reducing its uptake by the reticuloendothelial system (RES) (165,166). PEGylation, first described by Abuchowski *et al.*, (167,168) is a well established technology approved by the FDA for the modification of protein, peptides or non-peptide small bioactive molecules by covalent linking of one or more PEG polymer chains (usually as 1:1 PEG: protein ratio) in order to improve the pharmacokinetic profile (such as increased plasma half-life and longer systemic circulation), increase solubility, stability, bioavailability and therapeutic efficacy of the bioactive molecules as well as reducing antigenicity and immunogenicity of non-human proteins. Safety and conjugation efficiency of PEG depend on its molecular weight, site of conjugation and the surface chemistry of the linkers as well as the presenting clinical condition. Therefore protein PEGylation has provided the platform for the development of numerous polymer-drug conjugates for the treatment of various disease conditions. For example two PEG-interferon conjugates were approved by the FDA in the early 2000s as subcutaneous injections for the treatment of chronic hepatitis C. PEG-interferon  $\alpha$ -2a (Pegasys®) consists of recombinant human  $\alpha$ -2a interferon conjugated to a single branched PEG of molecular weight 40,000 g/mol while PEG-Intron® contains recombinant human interferon  $\alpha$ -2b conjugated to a single chain PEG of molecular weight 12,000 g/mol. Neulasta®, a PEGylated recombinant granulocyte colony-stimulating factor (G-CSF) containing 20,000 g/mol PEG was approved in 2002 by the FDA as subcutaneous injection for the treatment of cancer to minimize chemotherapy-induced neutropenia. Neulasta® exhibited prolonged systemic circulation and reduced renal elimination of the PEGylated GCSF compared to the unmodified protein which enabled single injection per chemotherapy cycle compared with the 10 injections per day required for the G-CSF alone (38,169-171).

Recently PEG-interferon conjugates have been developed further to extend their uses to other clinical indication for instance PEG-interferon  $\alpha$ -2b (Sylatron) has been approved in 2011 as an adjuvant therapy for the treatment of high risk melanoma (27) while PEG-interferon- $\beta$ -1a conjugate is in Phase III clinical trial for the treatment of multiple sclerosis (28). Other PEGylated products include PEG-asparaginase (Oncaspar®) (172), PEG-adenosine deaminase (Adagen®) (173), and PEG-growth hormone receptor antagonist (Somavert®) (174). Therefore large scale synthesis of PEGs with specific molecular weight and molecular weight distribution for various pharmaceutical applications over two decades has generated very useful post marketing database relating to their functions and clinical outcomes. Although there were concerns that the cost of manufacture may hinder commercialization of PEGylated products, pharmacoeconomic studies have demonstrated their cost effectiveness (175). Moreover as the first generation of PEGylated products begin to come off patents the advent of generic products will further reduce the cost of manufacturing.

PEGs are not biodegradable hence conjugates with hydrodynamic diameter of about 7 nm are usually preferred in order to avoid renal filtration (176). In the same vein conjugates of this size have potential for systemic accumulation resulting in undesirable side effects. They also exhibit low drug loading capacity because they contain only one or two terminal hydroxyl groups on the linear polymer chain that can be activated for conjugation (91). Nonetheless frantic research efforts have been made in this regard by synthesizing branched and multiarm PEGs which are biodegradable. For instance, multiarm PEG-camptothecin conjugate (EZN-2208) was synthesized by coupling a 40 kDa 4-pronged multiarm PEG with a poorly soluble drug, camptothecin (CPT) derivative, a potent topoisomerase II inhibitor. A glycine spacer was used to link the each arm of the PEG to the 20-hydroxyl group of CPT. The conjugate exhibited a remarkable increase in aqueous solubility (approximately 1000 folds); higher drug loading efficiency (3.7% w/w) compared to the linear PEG-CPT conjugate (1.7% w/w); longer blood circulation time with 207-fold increase in tumour exposure and superior antitumour efficacy in xenograft models of breast, colorectal and pancreatic cancer. The conjugate (EZN-2208) is still under clinical investigation for the treatment of patients with metastatic breast cancer (177,178)

It is important to note that PEGylated proteins most often lose their pharmacological activity. For instance, the PEGylated  $\alpha$ -interferon PEGASYS® retains only 7% of the antiviral activity of the native protein however pharmacokinetics and *in vivo* performance were remarkably improved (170). In order to overcome this challenge site-specific conjugation techniques have been developed where the enzyme transglutaminase was selectively PEGylated at the glutamine moiety of the protein to achieve degradable PEG-protein linkages and maximize the return of protein bioactivity (179). The extended polymer chain provides a hydrodynamic radius of about 5 – 10 times greater than the native protein thus preventing rapid renal clearance and prolonging the systemic circulation time of the bioactive agents. In the recent past special spacers and linkers between the drug and the polymer have been developed to release the drugs from the conjugates under predetermined specific conditions. Examples include *N*-cisaconityl acid spacer and hydrazon linker which are cleaved by acidic pH of the endosome.

The other concern regarding PEGylated products is the safety profile. For example intravenous administration of PEGylated liposomal doxorubicin (Doxil®) has been associated with infusion reactions in less than 10% of patient population which can be managed clinically. Hypersensitivity reactions due to PEG-induced anti-PEG IgM antibody production have also been reported (180). However the specificity of the anti-PEG antibody and standardization of its assay are not very clear and immunosuppressive strategies have been suggested to minimize the risk of such reactions. In spite of the current improvements on the application of PEGylation techniques and its established clinical values, some PEG conjugates with very high toxicity profile have been withdrawn from use or clinical trials. For instance PEG-L-asparaginase (Oncaspar®) presently used in the treatment of paediatric acute lymphocytic leukaemia (ALL) showed very poor tolerance during a Phase II clinical trial in advanced ovarian cancer patients and the trial was stopped (181). Another example is Peginesatide (Omontys®) a PEG conjugate of erythropoietin-stimulating peptide designed for the treatment of anaemia in haemodialysis patients with chronic kidney disease. The conjugate showed similar activity to human recombinant erythropoietins requiring less frequent administration with good safety profiles in patients on haemodialysis during the pre-approval clinical trial however higher rates of adverse cardiovascular events were reported in patients not on dialysis. The product was approved by the FDA in 2012 but was later withdrawn from the market in 2013 due to reports of serious hypersensitivity reactions including life-threatening anaphylaxis. It has been noted that the mechanisms of the unexpected toxicity of this conjugate are not yet understood therefore evaluation and quantification of conjugation-induced changes in physicochemical and biopharmaceutical properties of the bioactive molecules as well as batch to batch quality and process control would be of great value to understanding such mechanisms and improving polymer-drug conjugate design in general.

### ***N*-(2-hydroxypropyl)methacrylamide (HPMA)**

The drug carrying and delivery capacity of the hydrophilic *N*-(2-hydroxypropyl)methacrylamide (HPMA) synthetic copolymers have been widely investigated (149,182-184). For example, HPMA copolymer-doxorubicin conjugate (PK1, FCE28068) was the first of the series of synthetic polymer-anticancer drug conjugates developed in 1994 which entered clinical trial as anticancer agents (185,186). PK1 (MW 30kDa) containing 8.5% w/w doxorubicin consists of the anticancer anthracycline antibiotic doxorubicin attached to the HPMA copolymer backbone through tetrapeptide sequence glycylphenylalanylleucylglycine (GFLG) which is degradable by lysosimes (187). PK1 was reported to show remarkable stability as well as increased accumulation of doxorubicin in melanoma tumour (17 – 70 folds) and decreased cardio- and bone marrow toxicity in animals compared to free doxorubicin. Clinical evaluation of PK1 (phase II studies) demonstrated good tolerability with no doxorubicin side effects such as alopecia and cardiotoxicity at low doses up to 180 mg/m<sup>2</sup> and 1680 mg/m<sup>2</sup> respectively. However the clinical efficacy was not significant, only 6 partial responses were reported out of 56 volunteers in phase II studies (188). Therefore further research efforts were focused on formulation strategies to improve the delivery efficiency of HPMA copolymers including pH-modulated drug delivery systems and developing biodegradable forms of the copolymer with well defined physicochemical properties including star HPMA copolymer-drug conjugates and multiblock poly(HPMA) conjugates. The unique characteristics of HPMA copolymer include ability of the side chains (bioactive molecule, targeting groups, reactive groups and spacers) to be attached relatively easily through functionalized comonomers providing a wide array of conjugates containing a variety of drugs such as dexamethasone, taxanes, camptothecin *etc.* However the cleavage of the polymer-linker must release and reactivate the bioactive molecule at the targeted site of action. Therefore the drug linkers are usually designed to ensure hydrolytic stability during systemic transport and allow enzymatic cleavage by lysosomal enzymes at the target site. Model enzyme studies have shown that factors such as length and sequence of the peptide structure, structural conformation of the drug and drug loading capacity played significant roles in the stability and drug release kinetics of the conjugates.

### ***Dendrimers***

Many dendrimers and peptide dendritic polymers have been investigated as biomaterials used in polymer-drug conjugation because they have unique structural architecture with tunable physicochemical characteristics including surface charge density, surface functionality of the reactive groups, water solubility, conjugate stability and resistance to proteolytic digestion. They are hyper branched star-like three dimensional polymers with cavities between adjacent branches which provide a platform for conjugation of drugs directly to the surface of the polymer and drug encapsulation as well as facilitating solubilization of poorly soluble drugs. Compared with linear polymeric analogues such as PEG and HPMA the highly branched and globular architecture of these dendritic macromolecules exhibit properties such as increased water solubility, very low intrinsic viscosity and nanosize as well as increased cellular uptake and longer blood circulation time leading to increased drug accumulation at the target site (tumour). Positively charged poly(amidoamine) (PAMAM), poly(ethyleneimine) (PEI) and poly(propyleneimine) (PPI) dendrimers can complex with DNA as gene carrier while their potential use in the delivery of drug across biological membranes such as transdermal (189), intestinal epithelia cells (190), human placenta (191) and blood-brain barrier (192-194) are currently being investigated. They exhibit features such as modifiable surface groups, multifunctional moieties and monodispersed nanoscale size. Literature is replete with the fact that PAMAM dendrimers formed covalent and non-covalent complexes with poorly soluble drugs in aqueous solution which enhanced their solubility acting as vehicles for targeted drug delivery and controlled drug release (195). Their strong affinity for nucleic acids, lipid, proteins and bile salts can lead to disruption of biological activities and potential toxicity. Therefore the use of dendrimer based drug delivery systems in clinical evaluations has been limited due to concerns about biocompatibility and toxicity. Research efforts are being focused on surface modification of the dendrimer to increase their biocompatibility.

### ***Polymeric micelles***

Polymeric micelles are amphiphilic block-copolymers which have ability to self aggregate to form nanosize (1 – 200 nm) self assemblies consisting of the 'inner core' or 'core' and 'outer shell' or 'corona'. The inner core consists of the hydrophobic block which entraps the poorly soluble drugs and provides stability as well as controlled drug release characteristics. The most commonly used hydrophobic block as inner core for polymeric micelles include poly(D,L-lactide), poly(L-lactic acid) (PLLA), poly(DL-lactic-co-glycolic acid) (PLGA), polycaprolactone (PCL) and poly( $\beta$ -benzyl-L-aspartate) (PBLA) *etc.* (60). The corona consists of the hydrophilic block which represents the surface functionality which protects the polymeric micelles against intermicellar annihilation or precipitation and cell adhesion (196). PEG is the most extensively used hydrophilic block coronas in polymer micelles-drug delivery because of its highly hydrophilic nature, widespread

acceptance, abundant availability, low molecular weight, availability of a large number of hydroxyl groups, non-toxic nature, biocompatibility and ability to resist uptake by the reticuloendothelial system (RES). However other hydrophilic polymers such as poly(N-vinyl-2-pyrrolidone) (PVP), poly(vinylalcohol) (PVA), PEI have been investigated. As amphiphilic copolymers they form core-like aggregates (micelles) which enclose the hydrophobic regions into the inner core surrounded by the hydrophilic corona at specific polymer concentration commonly referred to as critical micelle concentration (CMC) in the range of  $10^{-6}$  to  $10^{-7}$  M (197). This unique phenomenon provides the platform for encapsulation and solubilization of poorly soluble drugs in the hydrophobic region (inner core) of the micelle while the surface can be modified or tailored to achieve desired *in vivo* pharmacokinetic properties of the polymer-drug conjugates. It is however important to note that when administered, dilution of the polymeric micelle-drug formulations occurs rapidly in the body resulting in reduced concentration of the micelle below its CMC and its stability may be compromised. An ideal polymeric micelle exhibits high drug loading capacity, biocompatibility, stability and controlled drug release however their CMC and other physicochemical properties are underpinned by the type and length of the hydrophilic and hydrophobic blocks. For instance greater hydrophobicity and longer hydrocarbon chain length of the block copolymer are associated with low CMCs (198-200).

Most of the polymeric micelles investigated did not contain any covalent bond between the drug and the micellar carrier hence may not be classified as polymer-drug conjugates. However some covalent polymeric micelles-drug conjugates have been developed including poly(ethylene glycol)-poly( $\epsilon$ -caprolactone) polymeric micelles containing chemically conjugated docetaxel (201). Recently continuous research efforts have been focused on the development of stimuli responsive (*smart*) and target specific polymeric micelles. Smart polymeric micelles have ability to respond to changes in environmental stimuli such as pH, ionic strength, temperature or externally applied heat, magnetic or electric fields, or ultrasound through conformational and/or electrostatic changes which can influence drug stability and release pattern. For instance the microenvironment of certain diseased areas such as tumors, inflammation or infarction are in hypoxic conditions which may cause extensive cell death resulting in drop of pH to about 6.5 below the normal blood pH of 7.4 (202,203). Also, remarkable pH changes may occur during the the normal physiological processes such as cellular uptake through endocytosis where the pH of the late endosomes may drop to 5.0 providing a gradient for triggering drug release (204). In these cases the polymer backbone can be made pH sensitive by including acidic (i.e. carboxylic and sulfonic acids) or basic (i.e. ammonium salts) groups that undergo protonation or deprotonation in response to changes in pH which in turn can lead to site specific drug release. An example of such smart polymeric micelles is doxorubicin conjugated to the side chain of the micelle-forming blocks exhibiting both time and pH dependent drug release with increased release at low pH (endosomal) conditions (205).

### 3.0 Preparation of polymer-drug nanoconjugates

Preparation of polymer-drug nanoconjugates involves either dispersion of the active drug in preformed polymers or *in situ* polymerization of monomers. It is well known that hydrophobic polymers can form nanoassembly during precipitation from dilute aqueous solutions at critical association concentration, similar to micelles of surfactants. Therefore nanoprecipitation requires water-miscible solvents at low concentrations, where the drug molecules are in a dispersed state, to ensure separation into nanodomain when non-solvent is added. The commonly used concentrations (e.g. 4 mg/ml) facilitate formation of nanoparticles with uniform size distribution. The process of polymer-drug nanoconjugate formation involves hydrophobizing the water-soluble polymer with the poorly soluble drugs followed by nanoprecipitation at critical micelle concentration. For example Hornig *et al.* dispersed aqueous solution of ibuprofen-sodium salt or naproxen in DMSO under continuous stirring for 24 h followed by addition of appropriate quantities of dextran and N,N-carbonyldiimidazole (CDI) with continuous stirring for 24 h at 80°C to allow reaction between the drug and the polymer. The final product was isolated by precipitation in large volume of water and washed several times followed by vacuum drying (206). This is a simple process however complete removal of the residual amount of organic solvent cannot be assumed. Therefore an efficient approach for complete exchange of solvent against water such as dialysis is recommended. We have utilized a combination controlled intrinsic solubility, polymer/drug ratios and charge screening techniques (dialysis) to prepare ibuprofen-Ddex and ibuprofen-chitosan nanoconjugates at room temperature without any organic solvent or toxic chemical initiator, providing a platform for low energy *green* and environmental friendly techniques (45,151,152).

### 3.1 Dispersion of active drug in preformed polymers

Several methods involving dispersion of drugs in preformed polymers that have been successfully utilized to prepare polymeric nanoparticles are discussed below.

#### 3.1.1 Solvent emulsification-diffusion (SED)

SED involves preparation of oil-in-water emulsion. The oil phase (volatile organic solvent) containing the polymer and drug is emulsified with the aqueous phase containing the stabilizer (usually PVA) for a predetermined period of time to form primary emulsion using a high shear mixer. Dichloromethane, acetone, methylene chloride, ethanol, chloroform and tetrahydrofuran (THF) have been widely used as the volatile organic solvents however ethylacetate is now preferred because of its better safety profile. Two emulsification strategies are possible including single emulsions e.g. oil-in-water (o/w) and double emulsions e.g. water-in-oil-in-water (w/o/w). These techniques usually require high speed homogenization or ultrasonication. The emulsion is then dispersed in large volume of water under continuous magnetic stirring at room temperature or under reduced pressure to allow diffusion and evaporation of the organic solvent leading to the formation of nanoparticle suspension. The nanoparticles are recovered by ultracentrifugation and washing with distilled water followed by lyophilization to obtain the solid polymer-drug nanoconjugates. Selection of organic solvent is critical to a successful formation of the nanoconjugates. For example partially soluble organic solvents (e.g. ethyl acetate, polyethylene glycol) that can dissolve both drug and polymer as well as easy to be removed safely are preferred. Also, the type of solvent, process parameters such as temperature, solvent evaporation technique, surfactant concentration, molecular weight of polymer, volume of internal aqueous phase can influence the particle size (PS), particle size distribution (PSD), zeta potential, polydispersity index and drug loading efficiency. This technique is most commonly used for the preparation of solid-lipid and polymeric nanoparticles. For example Niwa *et al.* prepared nafarelin-loaded PLGA nanospheres using a novel emulsion phase separation method as formulation strategy for encapsulation of hydrophobic drugs (207,208). As mentioned above, complete removal of the organic solvents cannot be assumed hence green environmentally friendly solvents are often preferred.

#### 3.1.2 Nanoprecipitation or solvent displacement

This method is based on interfacial deposition of polymer after the displacement of the organic solvent (partially soluble in water) from a lipophilic solution. This process involves rapid diffusion of the organic solvent into the aqueous phase which decreases interfacial tension between the two phases and increase in surface area. This phenomenon facilitates formation of fine droplets of the organic solvent even in the absence of mechanical stirring. The main disadvantage of this technique is low drug-entrapment efficiency especially for water soluble drugs. However modification of pH and ionic strength enhanced the drug loading efficiency of highly water-soluble procaine hydrochloride-loaded PLGA nanoparticles as reported by Fessi *et al.* (209). In most cases the solvent that gives the highest solubility of the chosen drug is selected however solvent-stabilizer interaction should be taken into cognizance. Literature is replete with different techniques of controlled precipitation for drug loaded nanoparticles. For example NanoMorph<sup>®</sup> technology has been used for many drug molecules which are in preclinical studies (210). The process involves preparing a suspension of the drug in organic solvent at higher temperatures to form a solution followed by a rapid mixing with a cooled aqueous solution containing the stabilizer in order to induce rapid nucleation and form spherical amorphous nanoparticles. When external factor such as ultrasonic waves is coupled with precipitation or any altered process parameter that could facilitate high gravity reactive precipitation, smaller PS and narrow PSD are often achieved (211).

#### 3.1.3 Salting-out

This technique is widely used because of its high yield potential, simplicity of operation, quick run and purity of final product. It does not require thermal treatment hence could be useful for the incorporation of thermolabile drugs. As described by Allemann *et al.*, the process entails the addition of a hydrophilic polymer stabilizer to a saturated solution of electrolyte (e.g. sodium chloride, calcium chloride and magnesium acetate) containing PVA as stabilizer, to form a viscous gel without the use of any high shear forces or surfactant. The polymer and drug are dissolved separately in organic solvent, usually acetone because of its solubilizing characteristics and



its ability to separate out from aqueous solution during salting out process. Subsequently the viscous gel is added to the organic phase with continuous stirring to form o/w emulsion. Water is then added in sufficient quantity to allow complete diffusion of acetone into the aqueous phase (salting out of the organic solvent) resulting into the formation of nanospheres, followed by cross-flow filtration to remove the electrolyte and organic solvent. In theory, dilution of the emulsion in a large volume of water reduces the concentration of the salt and electrolyte in the continuous phase leading to reverse salting out effect and precipitation of the polymer to produce the nanoparticles (212). It has been reported that poly(trimethylene carbonate) (PTMC)-dexamethasone nanoconjugate produced by salting out technique exhibited a size range of 183 – 251 nm and that the effect of polymer concentration and stirring rate on the particle size were less prominent compared to single emulsion technique (213). Other techniques include supercritical fluid technology; dialysis; micro- and nano- encapsulation; surface-mediated drug loading such as electrostatic drug loading and hydrogen bond-stabilized drug loading; diffusion mediated drug loading *etc.*

### 3.2 Polymerization of monomers

On the other hand methods involving polymerization of monomers include emulsion polymerization (214); miniemulsion polymerization (215); microemulsion polymerization (216); surfactant-free emulsions polymerization (217); interfacial polymerization (218); free radical polymerization (219) *etc.* We recommend that the choice of any of these techniques should be governed by critical quality attributes including safety profile, tunable degradation kinetics, ease of preparation, drug loading efficiency, efficient drug release kinetics, site-specific drug delivery and therapeutic effectiveness.

### 4.0 Drug loading strategies

Although there have been significant advancements in synthesis, characterization and *in vivo* therapeutic effects of polymer-drug conjugates, a successful loading of poorly soluble drug onto water soluble polymer and quantitative evaluation of the underpinning factors dictating their tunable size, stabilization, transport and drug delivery have been difficult. These factors which include physicochemical properties of the drug and polymer, method of drug loading, the local environment such as type of solvents, ionic strength, pH, temperature *etc.* are crucial in designing polymer-drug conjugates with controlled release profiles and predictable therapeutic effectiveness.

In most cases, drug loading capacity is underpinned by either covalent or non-covalent interaction between the polymer and drug. Covalent approach involves diffusion based loading strategy to form chemically bonded conjugates where the binding sites must be accessible and protected against possible hinderances such as electrostatic repulsion, steric repulsion, entropic repulsion *etc.* On the other hand non-covalent systems involving dynamic association (including hydrophobic, electrostatic, hydrogen bonding and steric immobilization) between drug and polymeric carriers within their local aqueous environment allow the loaded drug to diffuse to the surface of the corona and the target environment during drug delivery (220,221). The overall balance between these cooperative forces within the polymer-drug system is vital to the architecture, conformational flexibility, thermodynamic stability and the drug release mechanism from the conjugate. It is important to note that both covalent and non-covalent approaches require optimal loading capacity and efficient drug delivery at the target site of action; however which of the forces is dominant will govern the relative amount of bound drug, conjugate behaviour, drug release profile as well as therapeutic effectiveness of the nanoconjugate. It is apparent that exploring the impact of both covalent and non-covalent forces in polymer-drug nanoconjugate systems on drug loading efficiency, conjugate stabilization, conjugate transport and uptake as well as therapeutic effectiveness would provide a platform for future rational formulation design criteria that could facilitate transition of polymeric nanomedicines into clinical use.

Recent pharmaceutical research efforts have shown that design of polymer-drug conjugate formulations at molecular level are superior to conventional techniques in terms of therapeutic efficacy because of their ability to solubilize the hydrophobic drug, increase drug load, maintain the integrity of the polymer-drug complex under different thermodynamic and mechanical conditions, facilitate transport and control drug release at targeted site. For example one of the most widely used polymer in preparation of polymeric nanoparticles for the delivery of anticancer drugs is poly(lactic acid) (PLA) because of its excellent safety profile, tunable degradation kinetics and ease of synthesis (222). PLA-drug nanoconjugate has been prepared by co-precipitation technique however the nanoconjugates exhibited some formulation challenges such as ‘burst’ drug

release, low drug loading capacity and heterogeneous composition. These formulation challenges contributed to the difficulty in clinical translation and application of PLA-drug nanoconjugates.

In order to address these challenges, Tong and Chen developed PLA-drug nanoconjugates using drug-initiated ring-opening polymerization (ROP) of lactide followed by nanoprecipitation which enhanced loading efficiency remarkably as well as controlled drug release kinetics, narrow particle size distribution and negligible 'burst' drug release (223,224). The authors used low molecular weight PLA to achieve high drug loading however stability of nanoconjugates could be of great concern because low molecular weight PLA with short polymer chain has low polymer saturation point (*psp*) and could limit PLA-drug interaction which could lead to nanoconjugate disassembly. Increasing the hydrophobicity of PLA is one possible solution to enhance polymer-drug interaction and improve the stability of nanoconjugates. However, the side-chain methyl groups of PLA cannot be further modified making it difficult to modulate the hydrophilic/lipophilic balance of PLA. Therefore drug loading of polymeric nanoparticles prepared from conventional coprecipitation of drug and polymer are usually very low. For example, Yin *et al.* (225) used camptothecin (Cpt)/mPEG-PheLA<sub>100</sub> (5:95w/w) diblock copolymer to prepare Cpt-loaded nanoconjugates which exhibited particle diameter of 134 nm and polydispersity of 0.27 while drug loading efficiency was 28%. When they changed the Cpt/mPEG-PheLA<sub>100</sub> ratio to 25:75w/w the drug loading efficiency decreased to 5.5% indicating that increasing the amount of drug beyond the polymer saturation point will decrease conjugation efficiency. The authors also utilized hydroxyl-containing anticancer drugs (camptothecin (Cpt), paclitaxel (Ptxl), docetaxel (Dtxl) and doxorubicin (Drb)) to initiate controlled ring-opening polymerization of phenyl O-carboxyanhydride (Phe-OCA) derived from L-phenylalanine in order to enhance non-covalent hydrophobic characteristics and drug loading efficiency of the polymer. They prepared the drug-poly(Phe-OCA) conjugates (Cpt-PheLA<sub>n</sub>, where n is the degree of polymerization) by nanoprecipitation followed by self-assembly of Cpt-PheLA<sub>n</sub> conjugates in water to form nanoconjugates with well controlled physicochemical properties. They reported that poly(PheLA-OCA)-Cpt nanoconjugates exhibited 100% drug loading efficiency at PheLA-OCA/Cpt ratios of 25:1; 50:1 and 100:1 with narrow particle size distribution (100 – 125 nm), sustained drug release profiles without 'burst' drug release, remarkable stability in human serum with negligible aggregation and controlled cytotoxicity compared with PLA nanoconjugates (225). In this case it is possible to predict the drug loading efficiency from the PheLA-OCA/Cpt ratio used during polymerization. Therefore it is very important to control vital parameters such as hydrophilic/hydrophilic balance, polydispersity index and polymer-drug ratios to be able to tune the particle size, drug loading efficiency, drug solubility, drug release profiles, biodistribution, pharmacological activity and toxicity of the nanoconjugates. Further examples of polymer-anticancer nanoconjugates with their particles size and drug-loading efficiency are presented in Table 1.

In similar studies Hornig *et al.*, 2009 reported drug loading efficiency of 37 to 71% for a chemically synthesized ibuprofen-dextran (dextran ester) conjugates (206). Also 30% loading efficiency of ibuprofen in polymer-coated SiO<sub>2</sub> particles (226); 10% ibuprofen loading in lipid nanoparticles e.g. smectic cholesterol ester nanoparticles (227) and 9% ibuprofen in Eudragit polymeric nanoparticles (228) have been reported. The core-shell ibuprofen-Ddex nanoparticles prepared by complex coacervation technique also contained 32% ibuprofen (229). Jiang *et al.* (230) prepared ibuprofen-loaded Ddex nanoparticles with an average of 200nm size and 73-74% loading efficiency using Ddex and polylactide polymers crosslinked with glutaraldehyde. In all these studies toxic chemical reagents such as glutaraldehyde, anhydrous tetrahydrofuran (THF), dimethylsulfoxide (DMSO), N,N-dimethylacetamide (DMAc), N,N-dimethylformamide (DMF), methanol, ether and acetone were used which may constitute some safety and environmental concerns and non of the reports provided an account of the residual amount of organic solvent in the final product. Although the International Committee for Harmonization (ICH) has published a guideline (ICH Q3c) stating the limits for level of residual solvents allowed in drug products during normal manufacturing processes as supported by safety data and toxicity (ICH, 2011), solvents trapped within complex molecular structures of the conjugates are usually difficult to identify and quantitatively assessed. In an effort to avoid the use of organic solvents, we have utilized controlled electrostatic self-assembly in aqueous media to prepare ibuprofen (IB)-diethylaminoethyl dextran (Ddex) nanoconjugates (45) and ibuprofen (IB)-chitosan (CT) nanoconjugates (152). The intermolecular attraction between IB and Ddex/CT was amplified by optimizing the chemical potentials of both drug and polymer with controlled drug/polymer ratio, order of drug/polymer addition, critical association concentration (*cac*), intrinsic solubility (pH modulation) and charge screening (dialysis). These simple low energy green processes converted the rod-like ibuprofen crystals ( $453.88 \pm 29.8469 \times 97.12 \pm 5.4267 \mu\text{m}$ ) into nanoconjugates with particle size range of  $85.2 \pm 4.4461$  to  $157.10 \pm 10.0214$  nm, however they associated to form loose aggregates whose size increased from  $323.30 \pm 11.7144$  to  $1009.12 \pm 28.7991$  nm with increasing concentration of Ddex. The drug loading efficiency of IB-Ddex nanoconjugates increased from  $91.60 \pm 0.1617\%$  at 1:0.5 ibuprofen-Ddex weight ratio to a maximum of  $99.65 \pm 0.42777\%$  at 1:4 weight ratio followed by a steady decrease. Similarly, the IB-CT nanoconjugates exhibited spherical nanostructures with remarkable decrease in particle size ( $p < 0.05$ ;  $n =$

120) as concentration of chitosan increased (Figure 7E, 6F), losing the rod-like crystalline structure of pure ibuprofen. As chitosan concentration increased, particle size of IB-CT nanoconjugates decreased to sizes within nanometre range ( $14.96 \pm 1.1621 - 143.17 \pm 17.5247$  nm) however loose physical aggregates of size range  $223.58 \pm 10.5762$  to  $701.33 \pm 33.1684$  nm were noted with increasing concentration of chitosan. A maximum of  $98.75 \pm 5.6619$  % drug loading efficiency was achieved at  $26.24 \times 10^{-3}$  g/dm<sup>3</sup> chitosan similar to the trend of Ddex. We also investigated *ternary* polymer-drug-polymer conjugates as multifunctional controlled transdermal drug release strategy for poorly soluble drugs (151). The study focused on preparing a *ternary* ibuprofen-chitosan nanoassembly core in gellan shell in order to control the release properties of the nanoencapsulated ibuprofen. We noted that chitosan-gellan polyelectrolyte complex (PEC) without ibuprofen produced spherical core-shell microparticles between 15.93 and 87.45  $\mu$ m (Figure 7A). The maximum drug loading efficiency obtained in the *ternary* nanoconjugates was  $96.67 \pm 8.4838$  %.

From the foregoing, it is obvious that exploring the chemical potentials of polymers and bioactive agents to amplify and control polymer-drug conjugation at molecular level can produce new generations of polymeric nanoconjugates with well defined and tunable architecture. However specific parameters such as molecular weight, polydispersity, charge density and hydrophilic-hydrophobic balance must be well controlled in order to modulate the conjugate biodistribution, fate, biological activity and toxicity. Also, design of innovative polymer-drug nanoconjugates with targeting potential as well as validated techniques for conjugate characterization would be crucial for successful clinical and regulatory approval.

We have noted some research efforts on formulation factors such as type of drug loading solvents, hydrogen-bond stabilized drug loading and electrostatic drug loading, however it is important to note that optimization of polymer-drug conjugate design requires understanding of the interaction between polymer and drug and its impact on the physicochemical properties of the drug. In theory a higher drug loading efficiency and stabilization are desirable for therapeutic success however the number of accessible binding sites (*polymer saturation point*), critical association concentration (*cac*) of the drug and polymer as well as drug diffusion capacity may limit drug loading efficiency significantly. Currently research attention is being focused on polymer conjugates bearing both diagnostic and therapeutic agents to provide multifunctional carrier systems with potential combinatorial advantages.

In order to improve the physical, technical and biopharmaceutical characteristics of ibuprofen we have explored temperature quenching technique in combined aqueous crystallization and *in situ* granulation of ibuprofen to prepare ibuprofen-Ddex conjugate. It was noted that the intermolecular interaction between ibuprofen and Ddex produced a closely packed conjugate crystallites of ibuprofen crystals within the polymer matrix (Fig. 8A, 8B). On the other hand the self assembly technique produced a core-shell structure where ibuprofen molecule was internalized within the matrix (Fig. 8C, 8D). In this case the presence of Ddex changed the crystal habit from rod-like crystalline powder to self-assembled spherical, plate-like and amorphous interpenetrating crystal-granule conjugates (crystanules) with remarkably reduced crystal size and controlled (extended) release profiles relative to pure ibuprofen.

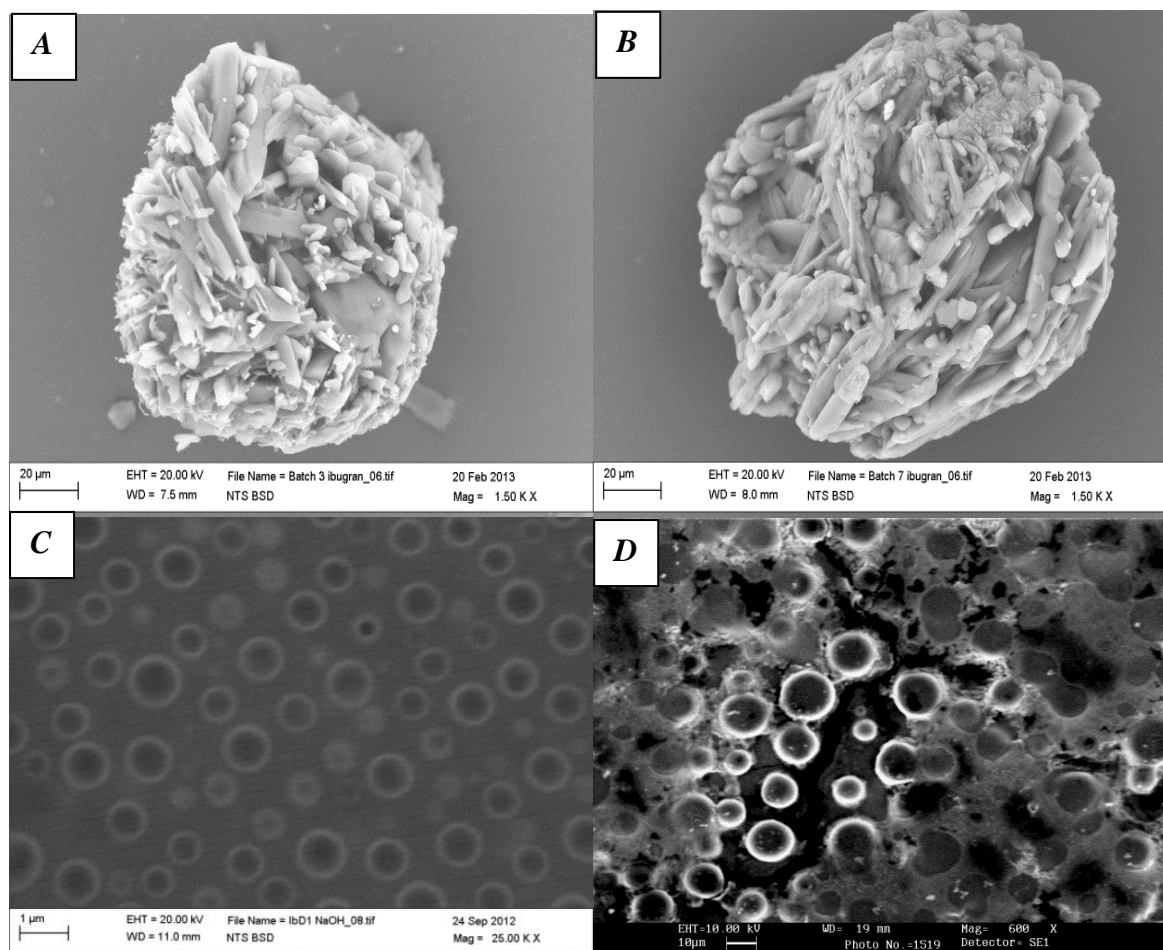

**FIGURE 8:** SEM Micrographs of internalized ibuprofen in Ddex spherical structure using combined crystallization and granulation A) below and B) above melting point of ibuprofen; C) low energy self-assembly technique and D) high energy conjugation technique

## 5.0 Optimization of nanoconjugates formulations

Formulation of polymer-drug nanoconjugates involves solvent diffusion technique where a solvent-in-water emulsion with partial water-miscibility is prepared and the bioactive molecules is nanosized by dissolving it in the solvent which is then added to a nonsolvent or by solvent evaporation to precipitate the nanoparticles in the presence of polymers or surfactants as stabilizing agents. It is important to note that selection of the solvent and stabilizer is critical to producing conjugates of nanometre range. In general, solvents with high water miscibility and stabilizers that can produce stable emulsions are usually preferred (231). The nanosized drugs can also be covalently or non-covalently conjugated to the polymer backbone directly or via biodegradable spacers or linkers as discussed above. For example Hornig *et al.* prepared dextran-drug conjugates by functionalizing water soluble biopolymer dextran with poorly water soluble drugs (ibuprofen and naproxen) through *in situ* activation of the carboxylic acid group with N,N-carbonyldiimidazole (CDI) to produce hydrophobic derivative which self-assembled by nanoprecipitation into nanoparticles with 37 – 71% drug loading efficiency (206). In this case the degree of substitution (DS) and the preparation technique dictate the particle size, particle size distribution, polydispersity index (PDI) and drug loading efficiency of the resulting nanoparticles. The robustness and stability of nanoconjugate formulation is underpinned by various formulation and process variables including selection of appropriate solvent, appropriate electrostatic and steric stabilizers and their optimum quantities as well as suitable polymer to drug ratio. The commonly used steric stabilizers are polymers while the electrostatic stabilizers include surfactants and electrolytes. For instance a suitable working polymer to drug ratio as a steric stabilizer is 0.05:1 to 0.5:1 however this should be investigated for each specific formulation. Higher concentrations of electrostatic stabilizers above the plateau of the adsorption isotherm can decrease the diffuse region of the electric double layer leading to a decrease in zeta potential and decreased physical stability. It is important that stabilizers accumulate at the interface of the nanosized drug particles to

provide steric or electrostatic barriers however the type and amount of stabilizers do have remarkable effects on the physical stability and *in vivo* behaviour of nanoconjugates. For example orally administered nanoconjugates may come in contact with the electrolytes in the gastro intestinal tract reducing electrostatic stability *in vivo* therefore optimal concentration of stabilizers or mixture of stabilizer is important to prevent such *in vivo* instability.

## 5.1 Quality by Design (QbD) principles

Pharmaceutical formulation of polymer-drug nanoconjugates is a complex and multistage process, therefore in order to produce the best nanoconjugate formulation the relationship between controllable formulation variables and the critical quality attributes must be well understood. One approach to this phenomenon is by changing one variable at a time (OVAT) while keeping the others as constant which may be laborious, expensive, time-consuming with unpredictable errors and sometimes not reproducible from batch to batch. Therefore a more efficient and economical systematic approach that utilizes statistical tools is required to predefine quality target product profile (QTPP) and the overall desired product quality based on excellent understanding of formulation and process variables. This approach, Quality by Design (QbD), has been explored by pharmaceutical industry to identify and evaluate the best practices for key elements in drug product development including Design of Experiment (DoE), risk assessment, process analytical technology (PAT), critical quality attributes (CQAs), QTPP and process characterization. The concept provides the rational balance between experiments, resources and time required for pharmaceutical formulations however it requires a sound understanding of the relationship between the vast number of possible formulation and process variables as well as their combined effects on product quality, safety and therapeutic efficacy with specific cognizance of quality risk management (QRM) in order to optimize formulation design and process techniques (232). Design of experiment is used to construct a design space where multidimensional interactions and combinations of input variables and process parameters are interrelated to demonstrate the influence of several independent variables on the system performance which may not be feasible with the traditional OVAT approach. One of the most popular DoE utilized in pharmaceutical development is the Response Surface Methodology (RSM) involving generation of multifactorial or polynomial mathematical relationships within and among the variables followed by mapping of the response within the experimental domain in order to select the optimal process parameters. Examples of RSM include Box-Behnken statistical design (BBD), central composite design, three-level factorial design and D-optimal design however BBD is more cost-effective because it requires fewer experimental runs and reduced time of optimization process. In this case it is possible to utilize the statistical design of experiment principles to screen and optimize formulation variables identifying the desirable combination of excipients within the design space for a model drug-polymer nanoconjugate specific for the indicated therapeutic activity.

For example as mentioned above, the architecture of polymer-drug nanoconjugates is maintained by either weak non-covalent or strong covalent bonds which may be broken prematurely either during storage by temperature changes or by pH changes and enzymatic action *in vivo* leading to nanoconjugate instability. Therefore formulation of polymer-drug nanoconjugates requires a thorough control of process parameters and formulation variables such as type of stabilizer, stabilizer concentration, polymer/drug ratios and processing factors such as mixing time, mixing rate, temperature, ionic strength, pH *etc.* because stability of the final product is critical to its safety and efficacy *in vivo*.

Application of QbD approach in polymer-drug formulation will provide a unique opportunity of continuous quality improvement that is required for safer, elegant and more effective product with excellent quality. The uniqueness of this approach is underpinned by the fact that the product and process performance characteristics are scientifically designed to meet the specific objectives; therefore the risk of failing to achieve the desired clinical attributes is quite low. The International Conference on Harmonization (ICH) Q8, Q9 and Q10 guidelines present the principles and strategies for the implementation and continuous improvement of QbD (233-235).

Crcarevska, *et al.* utilized the QbD concept to develop optimized microsponges as drug delivery carrier for topical gels using double emulsion-solvent diffusion technique in a rotor-stator homogenizer. They identified and justified the QTPP parameters (dosage form, route of administration, dosage strength, pharmacokinetics, stability, drug product quality attributes and container closure system) relative to the available literature data. They concluded that the relationship between the identified critical process parameters (CPP) and critical quality attributes (CQA) such as particle size and particle size distribution was well defined within the design space using one factor response surface method of DoE. However the residual organic solvents (acetone, class 3 and dichloromethane, class 2) in the final product (microsponge gel) as well as the degradation products may be critical to the safety of the product (236). Visser *et al.* also optimized the extemporaneous formulation of orodispersible films (ODF) using the QbD approach. The design space was determined using the Design

Expert<sup>®</sup> Software with predefined minimum and maximum CPP values. They demonstrated the influence of the CPPs on the CQAs using rational design of ODF, for example, increasing amount of glycerol rendered the ODF stickier which resulted into an undesirable decrease in tensile strength but a favourably low Young's modulus. They concluded that the optimal formulation for drug-loaded ODFs require slightly higher percentage of hydroxypropylmethyl cellulose (HPMC) (9.81 - 9.84%) and lower percentage of glycerol (12.27 – 12.35%) (237) compared with 9.0 and 22.1% previously reported for HPMC and glycerol respectively (238). Nanoconjugate formulation presents various challenges such as 'burst' drug release profile of 80 – 90% drug release within the first 10 h which could lead to systemic toxicity. Also, very low loading efficiency (1 – 5% w/w) is common in nanoconjugate systems, requiring large amount for therapeutic activity. For example, encapsulation efficiency of PLA-drug nanoconjugates varies from 10 to 90% w/w depending on the amount and intrinsic properties of the drug as well as its interaction with the polymer. Free non-conjugated drug may self-aggregate within the conjugate which may be difficult to remove, resulting in large heterogeneity in PS and PSD. Presently there is limited application of QbD principles to systematic development of nanoconjugates in literature. However in order to address these problems, many researchers have focused on ring opening polymerization (ROP) of lactide (LA) followed by nanoprecipitation of the resulting PLA-drug conjugate (223-225). The drug release from the nanoconjugate was tuned by controlled cleavage of the lactate ester bond between the drug and polymer by hydrolysis in the physiological solution. This technique increased loading efficiency remarkably to 100% w/w with negligible 'burst release and narrow PSD. However since PLA is hydrophobic, water and ions ( $H^+$  and  $OH^-$ ) do not have access to the ester linkage resulting in slow drug release profile. For example only 50% of camptothecin (CPT) was released from CPT-PLA nanoconjugate in phosphate buffer saline after two weeks at 37°C. Although this phenomenon can reduce side effects of CPT, it may be difficult to achieve maximum plasma concentration for therapeutic activity. In order to improve the efficacy of CPT-PLA nanoconjugate CPT was conjugated to terminal carboxylate group of the polylactide via hydrolysis-labile amino ester linker, to facilitate hydrolysis of the ester, using ROP technique. This was followed by coprecipitation with methoxy-poly(ethylene glycol) to facilitate self-assembly into nanoconjugates with well controlled physicochemical properties such as PS < 100nm; narrow PSD and controlled release kinetics. Improved release of CPT was reported without burst release.

## 6.0 Nanoconjugate characterization

The inadequate characterization of polymer-drug conjugates in literature has been linked to their poor preclinical results and failure of being transformed into clinical use (38). Some important parameters underpinning the physicochemical characteristics and pharmacological properties of PDCs include molecular weight and polydispersity of the polymer, conjugates' particle size (PS) and particle size distribution (PSD), conjugates stability during manufacture and storage, drug loading efficiency, polymer-drug interaction, drug release profiles and mechanism *etc.* Generally hydrophilic polymer carrying hydrophobic drug payloads have intrinsic tendency to form intramolecular aggregates and intermolecular interaction which may influence the limits of detection of the active drug by the assay techniques used and a consequent significant effect on the *in vitro* assay results. Current research efforts are exploring new quantitative analytical tools for the characterization of complex PDCs. Nanoconjugates are usually characterized by particle size (PS), particle size distribution (PSD), homogeneity and shape using dynamic light scattering (DLS) and scanning electron microscope respectively. The physical and chemical interaction between polymer and drug can be evaluated by Fourier Transform Infrared (FTIR) and Nuclear Magnetic Resonance (NMR) spectroscopies while thermal properties such as crystalline transformation, melting and degradation temperatures are investigated by Differential Scanning Calorimetry (DSC) and Thermogravimetric Analysis (TGA) and stability profiles are determined by accelerated thermal and photo stability of the nanoconjugates. By varying the formulation and process variables the particle size and their distribution can be tuned precisely. For example PS and PSD of the nanoconjugates strongly depend on the solvent used, concentration of the polymer solution as well as the degree and characteristics of the substituents. Hornig *et al.* have shown that nanoconjugates prepared by dialysis or dropping technique do not differ in their structure however PS tend to increase from 102 to 309 nm as degree of substitution increased from 0.5 to 2.08 while polydispersity index increased from 0.065 to 0.2333 suggesting remarkably reduced uniformity in PSD (206). They hypothesized that the hydrophobic ibuprofen molecules are located in interior of the nanoconjugate because it is well documented that dextran nanoparticles exhibit hydrophobic core. This hypothesis corresponds with our findings in ibuprofen-Ddex conjugates where ibuprofen molecule was internalized into the Ddex shell structure (Fig. 8C, 8D) (159). In order to optimize characterization of polymer-drug nanoconjugates and enhance the opportunity of successful translation into clinically useful nanomedicines, future trend of characterization techniques should include

molecular recognition of the polymer matrix at specific receptor at the cellular level including the specific drug targeting ligands.

## 7.0 Nanoconjugate stabilization

Polymers act as nanoparticle stabilizers by adsorption at the solid-liquid interface reducing the interfacial free energy which may lead to increased rate of nucleation of the drug substance. They also accumulate in the hydrodynamic layer between adjacent particles preventing their collision and subsequent aggregation (instability) by steric hindrance. Ionic polymers provide both steric hindrance and electrostatic repulsion to stabilize the nanoconjugates. However because of their higher solubility in water relative to non-ionic polymers, they exhibit reduced adsorption onto the particle surface hence reduced degree of supersaturation and reduced rate of nucleation of the drug resulting in increased particle size. We have demonstrated that concentrations of polymer above its polymer saturation point (*psp*) increased the size of the conjugate steadily (45). As mentioned above the selection of the suitable type of polymer and its optimal concentration are crucial for stabilizing the nanoconjugates as well as maintaining stability throughout the product life cycle. Adsorption of the polymer onto the drug particle surface is governed by thermodynamic and kinetic processes (151).

### 7.1 Steric stabilization

Steric hindrance can be achieved by providing effective barrier around the surface of the nanoparticle by surfactant or hydrophilic polymer in order to prevent aggregation when the particles approach each other. The physical properties of the stabilizer such as ligand flexibility, overall charge density, solubility and extent of polymer-drug interaction will dictate the efficiency of steric stabilization. In theory, thicker coatings of the stabilizer around the particle will increase interparticle distance and are therefore desirable for stability. On the other hand saturation of the particle surface with polymer may reduce drug diffusion or inhibit accessibility of drug release triggers such as enzymes. Hence there must be a balance between particle stability and drug release at the site of action for therapeutic effectiveness. Irrespective of the method used in preparing the nanoconjugates, the type of polymer is very important as the affinity of the polymer for the drug surface regulates its adsorption kinetics. In essence if the particle-particle affinity is greater than particle-polymer affinity, aggregation will occur depending on the drug/polymer ratio, particle size, particle size distribution as well as electrostatic and steric repulsions within the system. In theory, addition of sufficient amount of polymer in a good solvent would decrease interfacial tension at solid-liquid interface allowing complete coating of the drug particles to ensure steric repulsion and hence ensuring nanoconjugate stability. However poorly water soluble drugs with few H-bonding and greater hydrophobic interaction with the organic solvent may prevent the alignment of the drug particle in aqueous medium leading to insufficient coating by the stabilizer. Insufficient amount of polymer and/or slow adsorption of polymer onto the drug surface will result in uncoated particles, leading to particle aggregation as a result of particle-particle interaction. In general, the stability of drug nanoparticles in polymer is underpinned by interrelated factors including solvent characteristics, amount of polymer adsorbed (surface excess), affinity of the polymer to the drug surface, as well as adsorption kinetics. However if there is no affinity between the polymer and the drug particle surface, the attractive forces between drug particles become dominant due to depletion of polymer molecules between interparticle spaces. Higher affinity translates to faster adsorption which leads to production of smaller particle sizes. It is apparent that a good understanding of the drug-polymer interactions from the theoretical models as well as the effects of the physicochemical properties of drug and polymer on particle size, would facilitate better control of nanoconjugation process and the stability of the resulting nanoconjugates. It has been suggested that similar surface free energy between the drug and the polymer can provide better particle stabilization however specific drug-polymer interactions are more important deciding factors for the stability of the resulting particles (239). The authors reported that larger particles were obtained when both drug and polymer have the same –OH functionality.

Polymers with higher hydrophobicity and greater number of functional groups for H-bonding exhibit greater adsorption to the surface of poorly soluble drugs producing smaller nanoconjugates while those with higher molecular weights provide better stabilization.

The tendency of nanoconjugates to form reversible loose aggregates (flocculation) or irreversible aggregates (coagulation) are common phenomena in nanosystems underpinned by intermolecular (van der Waals) forces of

attraction. Therefore a drug that is successfully loaded onto a polymer backbone with maximum drug-loading efficiency must be stabilized in correlation with *in vitro* and *in vivo* release profiles as well as specific disease targeting and therapeutic effectiveness. Also, variation between pure solvents under ideal *in vitro* conditions and the *in vivo* biological fluids due to the inherent complexity of the biological environments and processes, may impact the stability and functionality of the nanoconjugate. For example, Cho *et al.* reported a remarkable over estimation of nanoparticle uptake into biological cells relative to the *in vitro* study due to nanoparticle sedimentation (240). It is apparent that rational design of polymer-drug nanoconjugates requires careful assessment of the forces that are needed to stabilize the nanosystem.

## 7.2 Electrostatic stabilization

The renowned Derjaguin, Landau, Verwey and Overbeek (DLVO) electric double layer theory of electrostatic repulsion may explain the fundamental stabilization mechanism for nanoconjugate systems. Dispersed drug molecules will normally acquire a charge from the dispersion medium through selective adsorption of specific ionic species from the medium; ionization of functional group situated on the surface of the particle (e.g. COOH) depending on the pH of the medium or difference in dielectric constant between the particle and the medium leading to particle-particle repulsion coordinated by counterions. Hence there is interplay of van der Waals forces of attraction and electrostatic repulsion forces (241). Higher zeta potential ensures separation of the particles by the electrostatic repulsive forces thereby stabilizing the system. The repulsive force, which can be estimated, depends on the ionic strength of the medium as well as the degree of the surface charge screening and temperature of the medium. For a physically stable nanosystem solely stabilized by electrostatic repulsion, a minimum zeta potential of  $\pm 30$  mV is required for stability however when there is combination of electrostatic and steric stabilization  $\pm 20$  mV may be sufficient (242). Therefore interaction between drug molecule and oppositely charged polymer may alter the surface charge density and the overall stability of the system.

## 8.0 Conclusion

Increasing evolution of poorly soluble drug candidates from high throughput screening and the increasing complexities of drug therapies as well as the increasing challenges of multiple drug resistance and therapeutic failure underpins the need for rational design of polymeric nanomedicines to develop innovative and more effective therapies. The versatility of the polymer architecture, conjugate conformation and bioresponsiveness provide a suitable platform for the rational design of polymer-drug nanoconjugates as a tool for effective delivery of poorly soluble drugs. In this vein, intensive research efforts have been made to develop novel and innovative polymer-drug conjugate systems that will provide controlled and site-specific delivery of bioactive molecules. However some unforeseen challenges have limited the successful transformation of this polymer therapeutics into clinically useful nanomedicines. Therefore none of the investigated polymer-drug conjugates is yet to reach the market. Nonetheless, the identified challenges have provided useful knowledge, understanding and experience to enable rational design of more robust and stable polymer-drug nanoconjugates for effective delivery of poorly soluble drugs. It is apparent that better understanding of the molecular bases of diseases and their progression, rational formulation of polymer-drug nanoconjugates as well as better characterization techniques are essential in order to meet the quality and regulatory requirements for successful transformation of PDNs into clinically useful nanomedicines.

## References

- (1) Connors RD, Elder EJ. Delivery of Poorly Soluble or Poorly Permeable Drugs . 4th ed. Fall Church, VA.: Technology Catalyst International Incorporation; 2003.
- (2) Lipinski CA, Lombardo F, Dominy BW, Feeney PJ. Experimental and Computational approaches to estimate solubility and permeability in discovery and development settings. *Advance Drug Delivery Reviews* 1997;23 (1-3):3 – 25.



- (3) Amidon GL, Lennernäs H, Shah VP, Crison JR. A theoretical basis for a biopharmaceutic drug classification: the correlation of in vitro drug product dissolution and in vivo bioavailability. *Pharm Res* 1995;12:413 – 420.
- (4) Leuner C, Dressman J. Improving drug solubility for oral delivery using solid dispersions. *European J Pharm Biopharm* 2000;50:82 – 85.
- (5) Li C, Wallace S. Polymer–drug conjugates: recent development in clinical oncology. *Adv Drug Deliv Rev* 2008;60(8):886–898.
- (6) Greco F, Vicent MJ. Polymer-drug conjugates: current status and future trends. *Frontiers in Bioscience* 2008;13:2744 – 2756.
- (7) Canal F, Sanchis J, Vicent MJ. Polymer-drug conjugates as nano-sized medicines. *Current Opinion in Biotechnology* 2011;22:894 – 900.
- (8) Vasey PA, Kaye SB, Morrison R, Twelves C, Wilson P, Duncan R, et al. Phase I clinical and pharmacokinetic study of PK1 [*N*-(2-hydroxypropyl)methacrylamide copolymer doxorubicin]: first member of a new class of chemotherapeutic agents – drug–polymer conjugates. *Clin Cancer Res* 1999;5(1):83–94.
- (9) Muggia FM. Doxorubicin-Polymer Conjugates: Further demonstration of the concept of Enhanced Permeability and Retention. *Clinical Cancer Research* 1999;5:7 – 8.
- (10) Minko T. Soluble polymer conjugates for drug delivery. *Drug Discovery Today: Technologies* 2005;2(1):15 – 20.
- (11) Duncan R. Polymer conjugates as anticancer nanomedicines. *Nat Rev Cancer* 2006;6(9):688–701.
- (12) Vicent MJ, Duncan R. Polymer conjugates: nanosized medicines for treating cancer. *Trends Biotechnol* 2006;24:39 – 47.
- (13) Minko T, Kopečková P, Pozharov V, Kopeček J. HPMA copolymer bound Adriamycin overcomes MDR1 gene encoded resistance in a human ovarian carcinoma cell line. *J Control Release* 1998;54:223 – 233.
- (14) International Conference on Harmonisation of Technical Requirements for Registration of Pharmaceuticals for Human use. Harmonised Tripartite Guideline on Impurities: Guideline for residual solvents. (Q3C (R5) ):4 February 2011.
- (15) Caron V, Tajber L, Corrigan OI, Healy AM. A comparison of spray drying and milling in the production of amorphous dispersions of sulfathiazole/polyvinylpyrrolidone and sulfadimidine/polyvinylpyrrolidone. *Mol Pharm* 2011;8(2):532 – 542.
- (16) Hancock BC, Parks M. True solubility advantage for amorphous pharmaceuticals. *Pharm Res* 2000;17:397 – 404.
- (17) Yang W, Johnston KP, Williams RO. Comparison of bioavailability of amorphous versus crystalline itraconazole nanoparticles via pulmonary administration in rats. *Eur J Pharm Biopharm* 2010;75(1):33 – 41.
- (18) Hoste K, De Winne K, Schacht E. Polymeric prodrugs. *Int J Pharm* 2004;277:119 – 131.
- (19) Khandare J, Minko T. Polymer-drug conjugates: progress in polymeric prodrugs. *Prog Polym Sci* 2006;31:359 – 397.
- (20) Rowe RC, Sheskey P, Owen SC. *Handbook of Pharmaceutical Excipients*. London, UK: Pharmaceutical Press; 2005.

- (21) Dumitriu S editor. *Polymeric Biomaterials*. New York, USA: Marcel Dekker Inc.; 2002.
- (22) Shelanski HA, Shelanski MV. PVP-iodine: history, toxicity and therapeutic uses. *J Int Coll Surg* 1956;25(6):727–734.
- (23) Ravin HA, Seligman AM, Fine J. Polyvinyl pyrrolidone as a plasma expander. *New Eng J Med* 1952;247(24):921–929.
- (24) Duncan R. The dawning era of polymer therapeutics. *Nat Rev Drug Discov* 2003;2(5):347–360.
- (25) Vincent MJ, Dieudonne L, Carbajo RJ, Pineda-Lucena A. Polymer conjugates as therapeutics: future trends, challenges and opprotunities. *Expert Opin Drug Deliv* 2008;5:593 – 614.
- (26) Vincent MJ, Ringsdorf H, Duncan R. Polymer therapeutics: clinical applications and challenges for development. *Adv Drug Deliv Rev* 2009;61:1117 – 1120.
- (27) Di Trollo R, Simeone E, Di Lorenzo G, Grimaldi AM, Romano A, Ayala F, et al. Update on PEG-interferon  $\alpha$ -2b as adjuvant therapy in melaloma. *Anticancer Res* 2012;32(9):3901 – 3909.
- (28) Kieseier BC, Calabresi PA. PEGylation of interferon- $\beta$ -1a: a promising strategy in multiple sclerosis. *CNS Drugs* 2012;26(3):205 – 214.
- (29) Pechar M, Ulbrich K, Subr V, Seymour LW, Schacht EH. Poly(ethylene glycol) multiblock copolymer as a carrier of anti-cancer drug doxorubicin. *Bioconjug Chem* 2000;11(2):131–139.
- (30) Etrych T, Chytil P, Mrkvan T, Sirova M, Rihova B, Ulbrich K. Conjugates of doxorubicin with graft HPMA copolymers for passive tumor targeting. *J Control Release* 2008;132(3):184–192.
- (31) Etrych T, Strohalm J, Chytil P, Cernoch P, Starovoytova L, Pechar M, et al. Biodegradable star HPMA polymer conjugates of doxorubicin for passive tumor targeting. *Eur J Pharm Sci* 2011;42(5):527–539.
- (32) Etrych T, Kovar L, Strohalm J, Chytil P, Rihova B, Ulbrich K. Biodegradable star HPMA polymer-drug conjugates: Biodegradability, distribution and anti-tumor efficacy. *J Control Release* 2011;154(3):241–248.
- (33) Yang J, Luo K, Pan H, Kopeckova P, Kopecek J. Synthesis of biodegradable multiblock copolymers by click coupling of RAFT-generated heterotelechelic polyHPMA conjugates . *React Funct Polym* 2011;71(3):294–302.
- (34) Luo K, Yang J, Kopeckova P, Kopecek J. Biodegradable multiblock poly[N-(2hydroxypropyl)methacrylamide] via reversible addition-fragmentation chain transfer polymerization and click chemistry. *Macromolecules* 2011;44(8):2481–2488.
- (35) Ringdorf H. Structure and properties of pharmacologically active polymers. *J Polym Sci Symp* 1975;51:135–153.
- (36) Ringdorf H. Synthetic polymeric drugs . In: Kostelnik RJ, editor. *Polymeric Delivery Systems* New York: Gordon and Breach Science Publiishers Inc.; 1978. p. 197 – 225.
- (37) Haag R, Kratz F. Polymer therapeutics: Concepts and applications. *Angew Chem Int Ed* 2006;45(8):1198–1215.
- (38) Duncan R. Polymer therapeutics: Top 10 selling pharmaceuticals – What next? . *Journal of Controlled Release* 2014;190:371 – 380.
- (39) Eichhorn ME, Strieth S, Dellian M. Anti-vascular tumour therapy: recent advances, pitfals and clinical perspectives. *Drug Resist Updat* 2004;7:427 – 436;.

- (40) Kim BYS, Rutka JT, Chan WCW. Nanomedicine. *N Engl J Med* 2010;363:2434 – 2443.
- (41) Duncan R, Vicent MJ. Polymer therapeutics – prospects for 21<sup>st</sup> century: the end of the beginning . *Adv Drug Deliv Rev* 2013;65:60 – 70.
- (42) Muller DG, Fang M, Desai A, Baker JR, Orr BG, Banaszak Holl MM. A quantitative assessment of nanoparticle-ligand distributions: implications for targeted drug and imaging delivery in dendrimer conjugates. *ACS Nano* 2010;4(2):657 – 670.
- (43) Muller DG, Banaszak Holl MM. Heterogeneous ligand-nanoparticle distributions: a major obstacle to scientific understanding and commercial translation. *Acc Chem Res* 2011;44(11):1135 – 1145.
- (44) Barz M, Canal F, Koynov K, Zentel R, Vicent MJ. Synthesis and in vitro evaluation of defined HPMA folate conjugates: influence of aggregation on folate receptor (*FR*) mediated cellular uptake ). *Biomacromolecules* 2010;11(9):2274 – 2282.
- (45) Abioye A, Kola-Mustapha A. Controlled electrostatic self-assembly of ibuprofen-cationic dextran nanoconjugates prepared by low energy green process - a novel delivery tool for poorly soluble drugs. *Pharmaceutical Research* 2015a;32:2110 - 2131.
- (46) Gimenez V, James V, Arminán A, Schweins R, Paul A, Vicent MJ. Demonstrating the importance of polymer conjugate conformation in solution on its therapeutic output: diethylstilbestrol (DES) polyacetals as prostate cancer treatment. *J Control Release* 2012;159(2):290 – 301.
- (47) Malugin A, Kopeckova P, Kopecek J. Liberation of doxorubicin from HPMA copolymer conjugate is essential for the induction of cell cycle arrest and nuclear fragmentation in ovarian carcinoma cells . *J Control Release* 2007;124(1-2):6–10.
- (48) Larson N, Ray A, Malugin A, Pike DB, Ghandehari H. HPMA copolymeraminohexylgeldanamycin conjugates targeting cell surface expressed GRP78 in prostate cancer. *Pharm Res* 2010;27(12):2683–2693.
- (49) Biopharma Cell Therapeutic Inc. Cell Therapeutic announces GOG completes patient enrollment in GOG-0212 Phase 3 clinical trial of Paclitaxel Poliglumex (Opaxio TM) as maintenance therapy in ovarian cancer. Available at: <http://investors.celltherapeutics.com/phoenix>. Accessed 20/11/2015.
- (50) Shino D, Murata Y, Kataoka K, Koyama Y, Yokoyama M, Okano T, et al. Preparation and characterization of a glucose-responsive insulin-releasing polymer device . *Biomaterials* 1994;15:121 – 128.
- (51) Bromberg LE, Ron ES. Temperature-responsive gels and thermogelling polymer matrices for protein and peptide delivery. *Adv Drug Deliv Rev* 1998;31:197 – 221.
- (52) Qui Y, Park K. Environment-sensitive hydrogels for drug delivery. *Adv Drug Deliv Rev* 2001;53:321 - 339.
- (53) Bajaj G, Van Alstine WG, Yeo Y. Zwitterionic chitosan derivative, a new biocompatible pharmaceutical excipient, prevents endotoxin-mediated cytokine release. *PLoS One* 2012;7(1):e30899.
- (54) Rao SB, Sharma CP. Use of chitosan as a biomaterial: studies on its safety and hemostatic potential. *J Biomed Mater Res* 1997;34(1):21 – 28.
- (55) Muzzarelli RA, Mattioli-Belmonte M, Pugnali A, Biagini G. Biochemistry, Histology and clinical uses of chitins and chitosans in wound healing. *EXS* 1999;87:251 – 264.
- (56) Kong M, Chen XG, Xing K, Park HJ. Antimicrobial properties of chitosan and mode of action: a state of the art review. *Int J Food Microbiol* 2010;144(1):51 – 63.

- (57) Li J, Wang G, Zhao Y, Liu W. Synthesis and characterization of a novel polydepsipeptide contained tri-block copolymer (MPEG-PLLA-PMMD) as self-assembly micelle delivery system for paclitaxel. *International Journal of Pharmaceutics* 2012;430:282 - 291.
- (58) Park EK, Kim SY, Lee SB, Lee YM. Folate-conjugated methoxypoly(ethylene glycol)-poly( $\epsilon$ -caprolactone) amphiphilic block copolymeric micelles for tumour-targeted drug delivery. *J Control Release* 2005;109:158 - 168.
- (59) Wang Y, Wang C, Gong CY, Wang YJ, Guo G, Luo F, et al. Polysorbate 80 coated poly( $\epsilon$ -caprolactone)-poly(ethylene glycol)-poly( $\epsilon$ -caprolactone) micelles for paclitaxel delivery. *International Journal of Pharmaceutics* 2012;434:1 - 8.
- (60) Park TG, Yoo HS. Biodegradable polymeric micelles composed of doxorubicin conjugated PLGA-PEG block copolymer. *J Control Rel* 2001;70:63 – 70.
- (61) Hami Z, Amini M, Khansari MZ, Rezayat SM, Gilani K. Doxorubicin-conjugated PLA-PEG-folate based polymeric micelle for tumour-targeted delivery: synthesis and in vitro evaluation. *DARU J Pharm Sci* 2014;22 - 30.
- (62) Kataoka K, Matsumoto M, Yokoyama M, Okano T, Sakurai T, Fukushima S, et al. Doxorubicin-loaded poly(ethyleneglycol)-poly(L-benzyl-L-aspartate) copolymer micelles: their pharmaceutical characteristics and biological significance. *J Control Release* 2000;64:143 - 153.
- (63) Han M, Diao YY, Jiang HI, Ying XY, Chen DW, Liang WQ, et al. Molecular mechanism study of chemosensitization of doxorubicin-resistant human myelogenous leukemia cells induced by a composite polymer micelle. *International Journal of Pharmaceutics* 2011;420(2):404 - 411.
- (64) Kataoka K, Kwon G, Naito M, Yokoyama M, Okano T, Sakurai Y. Block copolymer micelles for drug delivery: loading and delivery of doxorubicin. *J Control Release* 1997;48:195 - 201.
- (65) Cheng J, Tong R, inventors. Nanoconjugates and nanoconjugate formulations. US patent WO2011079279 A3. 2011 01/12/2011.
- (66) Leland WK, Chung L, Yang X, Cheng J, Tong R, inventors. Small molecule ligand-drug conjugates for targeted cancer therapy. US patent US20110085974 A1. 2011 14/04/2011.
- (67) Mirkin CA, Ko CH, Stegh A, Giljohann DA, Luciano J, Jensen SA, inventors. Nanoconjugates able to cross the blood-brain barrier. US patent US20150031745 A1. 2015 29/01/2015.
- (68) Black KL, Ljubimova JY, Ljubimov AV, Holler E, inventors. Polymalic acid based nanoconjugates for imaging. US patent EP2694117 A4. 2014 11/06/2014.
- (69) Manneh V, inventor. Therapeutic Nanoconjugates. US patent WO2009038776 A1. 2009 26/03/2009.
- (70) Cheng J, Tong R, inventors. Aptamer-coated paclitaxel-poly(lactide) nanoconjugates: Formulation and cancer targeting. US patent US61/289893; WO PCT/US2010/062030 (TF09151). 2010 .
- (71) Elvira C, Gallardo A, Roman JS, Cifuentes A. Covalent polymer-drug conjugates. *Molecules* 2005;10:114 - 125.
- (72) Meerum Terwogt JM, Ten Bokkel Huinink WW, Schellens JH, Schot M, Mandies IA, Zurlo MG, et al. Phase I clinical and pharmacokinetic study of PNU166945, a novel water-soluble polymer-conjugated prodrug of paclitaxel. *Anticancer Drugs* 2001;12(4):315–323.
- (73) Godwin A, Bolina K, Clochard M, Dinand E, Rankin S, Simic S, et al. New strategies for polymer development in pharmaceutical science – short review. *J Pharm Pharmacol* 2001;53:1175 – 1184.

- (74) Brocchini S, Duncan R. Polymer–drug conjugates: drug release from pendant linkers. In: Mathiowitz E, editor. *Encyclopaedia of controlled release* NY, USA: Wiley; 1999. p. 786–816.
- (75) Duncan R, Cable HC, Lloyd JB, Rejmanova P, Kopecek J. Polymers containing enzymatically degradable bonds: Design of oligopeptide side-chains in poly[N-(2-hydroxypropyl)methacrylamide] co-polymers to promote efficient degradation by lysosomal-enzymes. *Macromol Chem Macromol Chem Phys* 1983;184(10):1997–2008.
- (76) Duncan R, Ringsdorf H, Satchi-Fainaro R. Polymer therapeutics – polymers as drugs, drugs and protein conjugates and gene delivery systems: past, present and future opportunities. *J Drug Target* 2006;14:337 – 341.
- (77) Duncan R, Hume IC, Kopeckova P, Ulbrich K, Strohal J, Kopecek J. Anticancer agents coupled to N-(2-hydroxypropyl) methacrylamide copolymers 3. Evaluation of adriamycin conjugates against mouse leukaemia L1210 *in vivo*. *J Control Rel* 1989;10:51 – 63.
- (78) Duncan R, Hume IC, Yardley H, Flanagan P, Ulbrich K, Subr V, et al. Macromolecular prodrugs for use in targeted cancer chemotherapy: melphalan covalently coupled to N-(2-hydroxypropyl) methacrylamide copolymers. *J Control Rel* 1991;16:121 – 136.
- (79) Danhauser-Riedl S, Hausmann E, Schick HD, Bender R, Dietzfelbinger H, Rastetter J, et al. Phase I clinical and pharmacokinetic trial of dextran conjugated doxorubicin (AD-70, DOX-OXD). *Invest New Drugs* 1993;11:187 - 195.
- (80) Allen TM. Ligand-targeted therapeutics in anticancer therapy. *Nat Rev Cancer* 2002;2(10):750–763.
- (81) Seymour LW, Ferry D, Anderson D, Julyan P, Poyner R, Doran J, et al. Hepatic drug targeting: Phase I evaluation of polymer bound doxorubicin. *J Clin Oncol* 2002;20:1668 - 1676.
- (82) Brumlik MJ, Daniel BJ, Waehler R, Curiel DT, Giles FJ, Curiel TJ. Trends in immunoconjugate and ligand–receptor based targeting development for cancer therapy. *Expert Opin Drug Deliv* 2008;5(1):87–103.
- (83) Holmgren L, O’Reilly MS, Folkman J. Dormancy of micrometastases: balanced proliferation and apoptosis in the presence angiogenesis suppression. *Nat Med* 1995;1:149 – 153.
- (84) Folkman J. Successful treatment of an angiogenic disease. *N Engl J Med* 1989;320:1211 – 1212.
- (85) Naumov GN, Akslen LA, Folkman J. Role of angiogenesis in human tumour dormancy: animal models of the angiogenic switch. *Cell Cycle* 2006;5:1779 – 1787.
- (86) Alessi P, Ebbinghaus C, Neri D. Molecular targeting of angiogenesis. *Biochim Biophys Acta* 2004;1654:39 – 49.
- (87) Bissett D, Cassidy J, de Bono JS, Muirhead F, Main M, Robson L, et al. Phase I and pharmacokinetic (PK) study of MAG-CPT (PNU 166148): a polymeric derivative of camptothecin (CPT) . *Brit J Cancer* 2004;91:50-55.
- (88) Schoemaker NE, van Kesteren C, Rosing H, Jansen S, Swart M, Lieverst J, et al. A phase I and pharmacokinetic study of MAG-CPT, a water soluble polymer conjugate of camptothecin. *Brit J Cancer* 2002;87:608-614.
- (89) Bhatt R, de Vries P, Tulinsky J, Bellamy G, Baker B, Singer JW, et al. Synthesis and *in vivo* antitumor activity of poly (L-glutamic acid) conjugates of 20S-camptothecin. *J Med Chem* 2003;46:190-193.
- (90) Conover CD, Greenwald RB, Pendri A, Gilbert CW, Shum KL. Camptothecin delivery systems: enhanced efficacy and tumor accumulation of camptothecin following its conjugation to polyethylene glycol via a glycine linker. *Cancer Chemother Pharmacol* 1998;42:407-414.

- (91) Rowinsky EK, Rizzo J, Ochoa L, Takimoto CH, Forouzes B, Schwartz G, et al. A phase I and pharmacokinetic study of pegylated camptothecin as a 1-hour infusion every 3 weeks in patients with advanced solid malignancies. *J Clin Oncol* 2003;21:148 - 157.
- (92) Soepenber O, de Jonge MJA, Sparreboom A, de Bruin P, Eskens FALM, de Heus G, et al. Phase I and pharmacokinetic study of DE-310 in patients with advanced solid tumors. *Clin Cancer Res* 2005;11:703 - 711.
- (93) Schluep T, Hwang J, Cheng J, Heidel JD, Bartlett DW, Hollister B, et al. Preclinical efficacy of the camptothecin-polymer conjugate IT-101 in multiple cancer models. *Clin Cancer Res* 2006;12:1606 - 1614.
- (94) Schluep T, Cheng JJ, Khin KT, Davis ME. Pharmacokinetics and biodistribution of the camptothecin-polymer conjugate IT-101 in rats and tumor-bearing mice. *Cancer Chem Pharmacol* 2006;57:654 - 662.
- (95) Li J, Wang Y, Yang C, Wang P, Oelschlager DK, Zheng Y, et al. Polyethylene Glycosylated Curcumin Conjugate Inhibits Pancreatic Cancer Cell Growth through Inactivation of Jab1. *Molecular Pharmacol* 2009;76(1):81 - 90.
- (96) Varticovski L, Lu ZR, Mitchell K, de Aos I, Kopeck J. Water soluble HPMA copolymer-wartamannin conjugate retains phosphoinositide 3-kinase inhibitory activity in vitro and in vivo. *J Control Release* 2001;74(1-3):275 - 281.
- (97) Cassidy J. PK1: Results of Phase I studies. *Proc 5th Intl Symp on Polymer Therapeutics: From Laboratory to Clinical Practice Cardiff, UK 2000:20.*
- (98) Li C, Yu DF, Newman RA, Cabral F, Stephens LC, Hunter N, et al. Complete regression well-established tumors using a novel watersoluble poly (L-glutamic acid)-paclitaxel conjugate. *Cancer Res* 1998;58:2404 - 2409.
- (99) Matsumura Y, Maeda H. A new concept of macromolecular therapeutics in cancer chemotherapy: mechanism of tumor-tropic accumulation of proteins and the antitumor agents SMANCS. *Cancer Res* 1986;46:6387 - 6392.
- (100) Maeda H. The enhanced permeability and retention (EPR) effect in tumor vasculature: the key role of tumor-selective macromolecular drug targeting. *Adv Enzyme Regul* 2001;41:189 - 197.
- (101) Caliceti P, Veronese FM. Pharmacokinetic and biodistribution properties of poly(ethylene glycol)-protein conjugates. *Adv Drug Deliv Rev* 2003;55:1261 - 1277.
- (102) Hobbs SK, Monsky WL, Yuan F, Roberts WG, Griffith L, Torchilin VP, et al. Regulation of transport pathways in tumor vessels: role of tumor type and microenvironment. *Proc Natl Acad Sci USA* 1998;95:4607 - 4612.
- (103) Hashizume H, Baluk P, Morikawa S, McLean JW, Thurston G, Roberge S, et al. Openings between defective endothelial cells explain tumor vessel leakiness. *Am J Pathol* 2000;156:1363 - 1380.
- (104) Yuan F, Dellian M, Fukumura D, Leunig M, Berk DA, Torchilin VP, et al. Vascular permeability in a human tumor xenograft: molecular size dependence and cut-off size. *Cancer Res* 1995;55:3752 - 3756.
- (105) Duncan R, Vicent MJ, Greco F, Nicholson RI. Polymer-drug conjugates: towards a novel approach for the treatment of endocrine-related cancer. *Endocrine-Related Cancer* 2005;12:S189 - S199.
- (106) Maeda H. Tumor-selective delivery of macromolecular drugs via the EPR effect: background and future prospects. *Bioconjug Chem* 2010;21(5):797-802.

- (107) Maeda H, Bharate GY, Daruwalla J. Polymeric drugs for efficient tumor-targeted drug delivery based on EPR-effect . *Eur J Pharm Biopharm* 2009;71(3):409–419.
- (108) Greish K. Enhanced permeability and retention of macromolecular drugs in solid tumors: a royal gate for targeted anticancer nanomedicines. *J Drug Target* 2007;15(7-8):457–464.
- (109) Iyer AK, Khaled G, Fang J, Maeda H. Exploiting the enhanced permeability and retention effect for tumor targeting. *Drug Discov Today* 2006;11(17-18):812–818.
- (110) Schliemann C, Neri D. Antibody-based targeting of the tumour vasculature. *Biochim Biophys Acta* 2007;1776:175 – 192.
- (111) Christie RJ, Grainger DW. Design strategies to improve soluble macromolecular delivery constructs. *Adv Drug Deliv Rev* 2003;55:421 – 437.
- (112) Ray A, Larson N, Pike DB, Gruner M, Naik S, Bauer H, et al. Comparison of active and passive targeting of docetaxel for prostate cancer therapy by HPMA copolymer-RGDfK conjugates. *Mol Pharm* 2011;8(4):1090–1099.
- (113) Greish K, Ray A, Bauer H, Larson N, Malugin A, Pike D, et al. Anticancer and antiangiogenic activity of HPMA copolymer-aminohexylgeldanamycin-RGDfK conjugates for prostate cancer therapy. *J Control Release* 2011;151(3):263–270.
- (114) Mitra A, Mulholland J, Nan A, McNeill E, Ghandehari H, Line BR. Targeting tumor angiogenic vasculature using polymer-RGD conjugates . 2005;102(1):191–201.
- (115) Borgman MP, Aras O, Geysler-Stoops S, Sausville EA, Ghandehari H. Biodistribution of HPMA copolymer-aminohexylgeldanamycin-RGDfK conjugates for prostate cancer drug delivery. *Mol Pharm* 2009;6(6):1836–1847.
- (116) Pike DB, Ghandehari H. HPMA copolymer-cyclic RGD conjugates for tumor targeting. *Adv Drug Deliv Rev* 2010;62(2):167–183.
- (117) Arap W, Pasqualini R, Ruoslahti E. Cancer treatment by targeted drug delivery to tumour vasculature in a mouse model. *Science* 1998;279:377 - 380.
- (118) Ellerby HM, Arap W, Ellerby LM, Kain R, Andrusiak R, Rio GD, et al. Anti-cancer activity of targeted pro-apoptotic peptides . *Nat Med* 1999;5:1032 – 1038.
- (119) Segal E, Satchi-Fainaro R. Design and development of polymer conjugates as anti-angiogenic agents . *Advanced Drug Delivery Reviews* 2009;61:1159 – 1176.
- (120) Ikumi Y, Kida T, Sakuma S, Yamashita S, Akashi M. Polymer-phloridzin conjugates as an antidiabetic drug that inhibits glucose absorption through the Na<sup>+</sup>/glucose cotransporter (SGLT1) in the small intestine. *J Control Release* 2008;125:42 – 49.
- (121) Vicent MJ, Cascales L, Carbajo RJ, Cortes N, Messeguer A, Perez-Paya E. Nanoconjugates as intracorporeal neutralizers of bacterial endotoxins. *J Control Release* 2009;142:277 – 285.
- (122) Liu XM, Quan LD, Tian J, Laquer FC, Ciborowski P, Wand D. Synthesis of click PEG-dexamethasone conjugates for the treatment of rheumatoid arthritis. *Biomacromolecules*. 2010;11:2621 – 2628.
- (123) Santamaria B, Benito-Martin A, Ucerro AC, Aroeira LS, Reyero A, Vicent MJ, et al. A nanoconjugate Apaf-1 inhibitor protects mesothelial cells from cytokine-induced injury. *PLoS ONE* 2009;4:e6634.

- (124) Shunak S, Thomas S, Gianasi E, Godwin A, Jones E, Teo I, et al. Polyvalent dendrimer glucosamine conjugates prevent scar tissue formation. *Nat Biotechnol* 2004;22:977 - 984.
- (125) Mondragon L, Orzaez M, Sanclimens G, Moure A, Arminan A, Sepulveda P, et al. Modulation of cellular apoptosis with apoptotic protease-activating factor 1 (Apaf-1) inhibitors. *J Med Chem* 2008;51:521 – 529.
- (126) Pan H, Sima M, Kopeckova P, Wu K, Gao S, Liu J, et al. Biodistribution and pharmacokinetics studies of bone-targeting N-(2-hydroxypropyl)methacrylamide copolymer-alendronate conjugates. *Mol Pharm* 2008;5:548 – 558.
- (127) Greenwald RB, Choe YH, McGuire J, Conover CD. Effective drug delivery by PEGylated drug conjugates. *Adv Drug Deliv Rev* 2003;55:217 – 250.
- (128) Hershfield MS. Adenosine deaminase deficiency: clinical expression, molecular basis and therapy. *Semin Hematol* 1998;35:291 – 298.
- (129) Esslinger HU, Haas S, Maurer R, Lassman A, Dübbbers K, Müller-Peltzer H. Pharmacodynamic and safety results of PEG-Hirudin in healthy volunteers. *Thromb Haemost* 1997;77:911-919.
- (130) Yoo SD, Jun H, Shin BS, Lee HS, Park MO, Peluca PD, et al. Pharmacokinetic disposition of polyethylene glycol-modified salmon calcitonins in rats. *Chem Pharm Bull* 2000;48:1921-1924.
- (131) Greenwald RB, Pendri A, Bolikal D. Highly water soluble taxol derivatives. 7-Polyethylene glycol carbamates and carbonates. *J Org Chem* 1995;60:31-336.
- (132) Rapozzi V, Cogoi S, Soessotto P, Risso A, Bonora GM, Quadrifoglio F, et al. Antigene effect in K562 cells of a PEG-conjugated triples-forming oligonucleotide targeted to bcr1abl oncogene. *Biochemistry* 2002;41:502-510.
- (133) Hurwitz E, Klapper LN, Wilchek M, Yarden Y, Sela M. Inhibition of tumour growth by poly(ethylene glycol) derivatives of anti-ErbB2 antibodies. *Cancer Immunol Immunother* 2000;49:226-234.
- (134) Duncan R. Drug-polymer conjugates: potential for improved chemotherapy . *Anti-Cancer Drugs* 1992;3:175-210.
- (135) Putman D, Kopecek J. Polymer conjugates with anticancer activity. *Adv Polym Sci* 1995;112:55-123.
- (136) Maeda H. SMANCS and polymer-conjugated macromolecular drugs: advantages in cancer chemotherapy. *Adv Drug Deliv Rev* 1991;6:181-202.
- (137) Iwai K, Maeda H, Konno T. Use of oily contrast medium for selective drug targeting to tumour: enhanced therapeutic effect and X-ray image. *Cancer Res* 1984;44:2114-2121.
- (138) Oka K, Miyamoto Y, Matsumura Y, Tanaka S, Oda T, Suzuki F, et al. Enhanced intestinal absorption of a hydrophobic polymer-conjugated protein drug, SMANCS, in an oily formulation . *Pharmacol Res* 1990;7:852-855.
- (139) Elvira C, San Román J. Complexation of polymeric drugs based on polyacrylic chains with aminosalicic acid side group. *J Mater Sci : Mater Med* 1997;8:743-746.
- (140) Rodríguez G, Gallardo A, San Román J, Rebuelta M, Bermejo P, Buján J, et al. New resorbable polymeric systems with antithrombogenic activity . *J Mater Sci : Mater Med* 1999;10:873-878.
- (141) Gallardo A, San Román J. Synthesis and characterization of a new poly(methacrylamide) bearing side groups with biomedical interest . *Polymer* 1993;34:394-400.



- (142) Ortiz C, Vázquez B, San Román J. Synthesis, characterization and properties of polyacrylic systems derived from vitamin E. *Polymer* 1998;39:4107-4114.
- (143) Greco F, Vicent MJ. Combination therapy: opportunities and challenges for polymer-drug conjugates as anticancer nanomedicines. *Advanced Drug Delivery Reviews* 2009;61:1203 – 1213.
- (144) Kaneda Y, Tsutsumi Y, Yoshioka Y, Kamada H, Yamamoto Y, Kodaira H, et al. The use of PVP as a polymeric carrier to improve the plasma half-life of drugs . *Biomaterials* 2004;25(16):3259–3266.
- (145) Kamada H, Tsutsumi Y, Yamamoto Y, Kihira T, Kaneda Y, Mu Y, et al. Antitumor activity of tumor necrosis factor- $\alpha$  conjugated with polyvinylpyrrolidone on solid tumors in mice. *Cancer Res* 2000;60(22):6416–6420.
- (146) Yasukawa T, Kimura H, Tabata Y, Miyamoto H, Honda Y, Ikada Y, et al. Targeted delivery of anti-angiogenic agent TNP-470 using water-soluble polymer in the treatment of choroidal neovascularization . *Invest Ophthalmol Vis Sci* 1999;40(11):2690–2696.
- (147) Chipman SD, Oldham FB, Pezzoni G, Singer JW. Biological and clinical characterization of paclitaxel polyglumex (PPX, CT-2103), a macromolecular polymer-drug conjugate . *Int J Nanomedicine* 2006;1(4):375–383.
- (148) Ljubimova JY, Fujita M, Ljubimov AV, Torchilin VP, Black KL, Holler E. Poly(malic acid) nanoconjugates containing various antibodies and oligonucleotides for multitargeting drug delivery . *Nanomedicine* 2008;3(2):247–265.
- (149) Kopecek J, Kopeckova P. HPMA copolymers: origins, early developments, present, and future . *Adv Drug Deliv Rev* 2010;62(2):122–149.
- (150) Luo Y, Wang Q. Recent development of chitosan-based polyelectrolyte complexes with natural polysaccharides for drug delivery. *International Journal of Biological Macromolecules* 2014;64:353 – 367.
- (151) Abioye A, Armitage A, Kola-Mustapha AT. Thermodynamic changes induced by intermolecular interaction between ibuprofen and chitosan: effect on crystal habit, solubility and in vitro release kinetics of ibuprofen. *Pharmaceutical Research* 2015d;First online:DOI 10.1007/s11095-015-1793-0.
- (152) Abioye A, Issah S, Kola-Mustapha A. Ex vivo skin permeation and retention studies on chitosan-ibuprofen-gellan ternary nanogel prepared by in situ ionic gelation technique - a tool for controlled transdermal delivery of ibuprofen. *International Journal of Pharmaceutics* 2015c;490:112-130.
- (153) Vandamme TF, Lenourry C, Charreau M, Chaumeil JC. The use of polysaccharides to target drugs to the colon . *Carbohydrate Polymers* 2002;48:219.
- (154) Lee JS, Jung YJ, Doh M, Kim YM. Synthesis and properties of dextran-nalidixic acid ester as a colon-specific prodrug of nalidixic acid. *Drug Dev Ind Pharm* 2001;27(4):331 - 336.
- (155) McLeod AD, Friend DR, Tozer TN. Glucocorticoid-dextran conjugates as potential prodrugs for colon-specific delivery: hydrolysis in rat gastrointestinal tract contents. *J Pharm Sci* 1994;83(9):1284 – 1288.
- (156) Dang W, Colvin HB, Saltzman WM. Covalent coupling of methotrexate to dextran enhances the penetration of cytotoxicity into a tissue-like matrix. *Cancer Research* 1994;54(7):1729 - 1735.
- (157) Ichinose K, Tomiyama N, Nakashima M, Ohya Y, Ichikawa M, Ouchi T, et al. Antitumour activity of dextran derivatives immobilizing platinum complex (II). *Anti-Cancer Drugs* 2000;11:33 – 38.

- (158) Sugahara S, Kajiki M, Kuriyama H, Kobayashi TR. Paclitaxel delivery systems: the use of amino acid linkers in the conjugation of paclitaxel with carboxymethyl-dextran to create prodrug. *Biol Pharm Bull* 2002;25(5):632 - 641.
- (159) Abioye A, Kola-Mustapha A, Ruparelia K. Impact of *in situ* granulation and temperature quenching on crystal habit and micromeritic properties of ibuprofen-cationic dextran conjugate crystallites. *International Journal of Pharmaceutics* 2014a;462 (1-2):83 - 102.
- (160) Abioye, A., Kola-Mustapha, A., Chi, G.T., Iliya, S. Quantification of *in situ* granulation-induced changes in pre-compression, solubility, dose distribution and intrinsic *in vitro* release characteristics of ibuprofen-cationic dextran conjugate crystallites. *International Journal of Pharmaceutics* 2014b;471 (1-2):453 - 477.
- (161) Abioye A, Kola-Mustapha A. Formulation studies on ibuprofen sodium-cationic dextran conjugate: effect on tableting and dissolution characteristics of ibuprofen. *Drug Development and Industrial Pharmacy* 2015b.
- (162) Dodziuk H editor. *Cyclodextrins and their complexes*. Weinheim: Wiley-VCH; 2006.
- (163) Kurkov SV, Loftsson T. Cyclodextrins. *International Journal of Pharmaceutics* 2013;453(1):167 – 180.
- (164) Kiss T, Fenyvesi F, Bácskay I, Váradi J, Fenyvesi E, Iványi R, et al. Evaluation of the cytotoxicity of beta-cyclodextrin derivatives: evidence for the role of cholesterol extraction. *Eur J Pharm Sci* 2010;40(4):376 -380.
- (165) Pasut G, Sergi M, Veronese FM. Anti-cancer PEG-enzymes: 30 years, old, but still a current approach. *Adv Drug Deliv Rev* 2008;60(1):69–78.
- (166) Veronese FM, Harris JM. Theme issue on "Peptide and Protein Pegylation". *Adv Drug Deliv Rev* 2002;54(4):453–606.
- (167) Abuchowski A, McCoy JR, Palczuc NC, van Es T, Davis FF. Effect of covalent attachment of polyethylene glycol on immunogenicity and circulating life of bovine liver catalase. *J Biol Chem* 1977;252:3582 – 3586.
- (168) Abuchowski A, van Es T, Palczuc NC, Davis FF. Alteration of immunological properties of bovine serum albumin by covalent attachment of polyethylene glycol. *J Biol Chem* 1977;252:3578 – 3581.
- (169) Roelfsema F, Biermasz NR, Pereira AM, Romijn J. Nanomedicines in the treatment of acromegaly: focus on pegvisomant. *Int J Nanomedicine* 2006;1(4):385–398.
- (170) Bailon P, Palleroni A, Schaffer CA, Spence CL, Fung WJ, Porter JE, et al. Rational design of a potent, long-lasting form of interferon: a 40 kDa branched polyethylene glycol-conjugated interferon alpha-2a for the treatment of hepatitis C. *Bioconjug Chem* 2001;12(2):195–202.
- (171) Wang YS, Youngster S, Grace M, Bausch J, Bordens R, Wyss DF. Structural and biological characterization of pegylated recombinant interferon alpha-2b and its therapeutic implications. *Adv Drug Deliv Rev* 2002;54(4):547–570.
- (172) Graham ML. Pegaspargase: a review of clinical studies. *Adv Drug Deliv Rev* 2003;55(10):1293– 1302.
- (173) Levy Y, Hershfield MS, Fernandez-Mejia C, Polmar SH, Scudiero D, Berger M, et al. Adenosine deaminase deficiency with late onset of recurrent infections: response to treatment with polyethylene glycol-modified adenosine deaminase. *J Pediatr* 1988;113(2):312–317.
- (174) Trainer PJ, Drake WM, Katznelson L, Freda PU, Herman-Bonert V, van der Lely AJ, et al. Treatment of acromegaly with the growth hormone-receptor antagonist pegvisomant. *N Engl J Med* 2000;342(16):1171– 1177.

- (175) Becker R, Dembek C, White LA, Garrison LP. The cost offsets and cost effectiveness associated with PEGylated drugs: a review of the literature. *Expert Rev Pharmacoecon Outcomes Res* 2012;12(6):775 – 793.
- (176) Fang J, Nakamura H, Maeda H. The EPR effect: Unique features of tumor blood vessels for drug delivery, factors involved, and limitations and augmentation of the effect. *Adv Drug Deliv Rev* 2011;63(3):136–151.
- (177) Zhao H, Rubio B, Sapra P, Wu D, Reddy P, Sai P, et al. Novel prodrugs of SN38 using multiarm poly(ethylene glycol) linkers. *Bioconjug Chem* 2008;19(4):849–859.
- (178) Sapra P, Zhao H, Mehlig M, Malaby J, Kraft P, Longley C, et al. Novel delivery of SN38 markedly inhibits tumor growth in xenografts. including a camptothecin-1 refractory model. *Clin Cancer Res* 2008;14(6):1888–1896.
- (179) Sato H. Enzymatic procedure for site-specific PEGylation of proteins. *Adv Drug Deliv Rev* 2002;54:487 – 504.
- (180) Hashimoto Y, Shimizu T, Mima Y, Abu Lila AS, Ishida T, Kiwada H. Generation, characterization and *in vivo* biological activity of two distinct monoclonal anti-PEG IgMs. *Toxicol Appl Pharmacol* 2014;277(1):30 - 38.
- (181) Hays JL, Kim G, Walker A, Annunziata CM, Lee JM, Squires J, et al. A phase II clinical trial of polyethylene glycol-conjugated L-asparaginase in patients with advanced ovarian cancer: early closure for safety. *Mol Clin Oncol* 2013;1(3):565 – 569.
- (182) Duncan R. Development of HPMA copolymer-anticancer conjugates: clinical experience and lessons learnt. *Adv Drug Deliv Rev* 2009;61(13):1131–1148.
- (183) Duncan R, Vicent MJ. Do HPMA copolymer conjugates have a future as clinically useful nanomedicines? A critical overview of current status and future opportunities. *Adv Drug Deliv Rev* 2010;62(2):272–282.
- (184) Lammers T. Improving the efficacy of combined modality anticancer therapy using HPMA copolymer-based nanomedicine formulations. *Adv Drug Deliv Rev* 2010;62(2):203–230.
- (185) Duncan R. N-(2-hydroxypropyl)methacrylamide copolymer conjugates . In: Kwon GS, editor. *Polymeric Drug Delivery Systems* New York: Marcel Dekker; 2005. p. 1 – 92.
- (186) Duncan R, Coatsworth JK, Burtles S. Preclinical toxicology of a novel polymeric antitumour agent: HPMA copolymer-doxorubicin (PK1). *Hum Exp Toxicol* 1998;17(2):93–104.
- (187) Duncan R, Seymour LW, O'Hare KB, Flanagan PA, Wedge S, Hume IC, et al. Preclinical evaluation of polymer-bound doxorubicin. *J Control Release* 1992;19(1-3):331–346.
- (188) Seymour LW, Ferry DR, Kerr DJ, Rea D, Whitlock M, Poyner R, et al. Phase II studies of polymer-doxorubicin (PK1, FCE28068) in the treatment of breast, lung and colorectal cancer. *Int J Oncol* 2009;34(6):1629–1636.
- (189) Cheng Y, Xu Z, Ma M, Xu T. Dendrimers as drug carriers: applications in different routes of drug administration. *J Pharm Sci* 2008;97(1):123–143.
- (190) Wiwattanapatapee R, Carreno-Gomez B, Malik N, Duncan R. Anionic PAMAM dendrimers rapidly cross adult rat intestine *in vitro*: a potential oral delivery system? . *Pharm Res* 2000;17(8):991–998.
- (191) Menjoge AR, Rinderknecht AL, Navath RS, Faridnia M, Kim CJ, Romero R, et al. Transfer of PAMAM dendrimers across human placenta: prospects of its use as drug carrier during pregnancy. *J Control Release* 2011;150(3):326–338.

- (192) Beg S, Samad A, Alam MI, Nazish I. Dendrimers as novel systems for delivery of neuropharmaceuticals to the brain. *CNS Neurol Disord Drug Targets* 2011;10(5):576–588.
- (193) He H, Li Y, Jia XR, Du J, Ying X, Lu WL, et al. PEGylated Poly(amidoamine) dendrimer-based dual-targeting carrier for treating brain tumors. *Biomaterials* 2011;32(2):478–487.
- (194) Ke W, Shao K, Huang R, Han L, Liu Y, Li J, et al. Gene delivery targeted to the brain using an Angiopep-conjugated polyethyleneglycol-modified polyamidoamine dendrimer. *Biomaterials* 2009;30(36):6976–6985.
- (195) Tanis I, Karatassos K. Association of a weakly acidic anti-inflammatory drug (ibuprofen) with a poly(amidoamine) dendrimer as studied by molecular dynamics simulations. *J Phys Chem B* 2009;113:10984–10993.
- (196) Otsuka H, Nagasaki Y, Kataoka K. PEGylated nanoparticles for biological and pharmaceutical applications. *Adv Drug Del Rev* 2003;55:403–419.
- (197) Torchilin VP. Micellar nanocarriers: pharmaceutical perspectives. *Pharm Res* 2007;24(1):1–16.
- (198) Hu Y, Jiang Z, Chen R, Wu W, Jiang X. Degradation and degradation-induced reassembly of PVP-PCL micelles. *Biomacromolecules* 2010;11(2):481–488.
- (199) Orienti I, Zuccari G, Fini A, Rabasco AM, Carosio R, Raffaghello L, et al. Modified doxorubicin for improved encapsulation in PVA polymeric micelles. *Drug Deliv* 2005;12(1):15–20.
- (200) Mishra D, Kang HC, Bae YH. Reconstitutable charged polymeric (PLGA)(2)-b-PEI micelles for gene therapeutics delivery. *Biomaterials* 2011;32(15):3845–3854.
- (201) Mikhail AS, Allen C. Poly(ethylene glycol)-b-poly(epsilon-caprolactone) micelles containing chemically conjugated and physically entrapped docetaxel: synthesis, characterization, and the influence of the drug on micelle morphology. *Biomacromolecules* 2010;11(5):1273–1280.
- (202) Vaupel P, Kallinowski F, Okunieff P. Blood flow, oxygen and nutrient supply, and metabolic microenvironment of human tumors: a review. *Cancer Res* 1989;49(23):6449–6465.
- (203) Wike-Hooley JL, Haveman J, Reinhold HS. The relevance of tumour pH to the treatment of malignant disease. *Radiother Oncol* 1984;2(4):343–366.
- (204) Gerweck LE, Seetharaman K. Cellular pH gradient in tumor versus normal tissue: potential exploitation for the treatment of cancer. *Cancer Res* 1996;56(6):1194–1198.
- (205) Bae Y, Fukushima S, Harada A, Kataoka K. Design of environment-sensitive supramolecular assemblies for intracellular drug delivery: polymeric micelles that are responsive to intracellular pH change. *Angew Chem Int Ed Engl* 2003;42(38):4640–4643.
- (206) Hornig S, Bunjes H, Heinze T. Preparation and characterization of nanoparticles based on dextran–drug conjugates. *J Colloid Interf Sci* 2009;338:56–62.
- (207) Niwa T, Takeuchi H, Hino T, Kunou N, Kawashima Y. Preparation of biodegradable nanospheres of water-soluble and insoluble drugs with D,L-lactide/glycolide copolymer by a novel spontaneous emulsification solvent diffusion method and the drug release behavior. *J Control Release* 1993;25:89–98.
- (208) Niwa T, Takeuchi H, Hino T, Nohara M, Kawashima Y. Biodegradable submicron carriers for peptide drugs: preparation of DL-lactide/glycolide copolymer (PLGA) nanospheres with nafarelin acetate by a novel emulsion-phase separation method in an oil system. *Int J Pharm* 1995;121:45–54.

- (209) Fessi H, Puisieux F, Devissaguet JP, Ammoury N, Benita S. Nanocapsule formation by interfacial polymer deposition following solvent displacement. *Int J Pharm* 1989;55:R1 – R4.
- (210) Shi Y, Porter W, Merdan T, Li LC. Recent advances in intravenous delivery of poorly water-soluble compounds. *Expert Opin Drug Del* 2009;6:1261 – 1282.
- (211) Sinha B, Müller RH, Möschwitzer JP. Bottom-up approaches for preparing drug nanocrystals: Formulations and factors affecting particle size. *Int J Pharm* 2013;453:126 – 141.
- (212) Allemann E, Leroux JC, Gurny R, Doelker E. *In vitro* extended release properties of drug-loaded poly(DL-lactic acid) nanoparticles produced by a salting out procedure. *Pharm Res* 1993;10:1732 – 1737.
- (213) Zhang Z, Grijpma DW, Feijen J. Poly(trimethylene carbonate) and monomethoxy poly(ethylene glycol), block-poly(trimethylene carbonate) nanoparticles for the controlled release of dexamethasone. *J Control Release* 2006;111:263 - 270.
- (214) Thickett SC, Gilbert RG. Emulsion polymerization: state of the art in kinetics and mechanisms. *Polymer* 2007;48:6965 – 6991.
- (215) Wang S, Wang X, Zhang Z. Preparation of polystyrene particles with narrow particle size distribution by  $\gamma$ -ray initiated miniemulsion polymerization stabilized by polymeric surfactant. *Eur Polym J* 2007;43:178 – 184.
- (216) Candau F. Polymerizations in microemulsions . In: Paleos CM, editor. *Polymerization in organized media* Philadelphia, US: Gordon & Breach Science Publishers; 1992. p. 215 – 282.
- (217) Hearn J, Wilkinson MC, Goodall AR, Chainey M. Kinetics of the surfactant-free emulsion polymerization of styrene: the post nucleation stage. *J Polym Sci Polym Chem Ed* 1985;23:1869 – 1883.
- (218) Gaudin F, Zydowicz NS. Core-shell biocompatible polyurethane nanocapsules obtained by interfacial step polymerization in miniemulsion. *Colloid Surf A* 2008;331:133 – 142.
- (219) Matyjaszewski K, Xia J. Atom transfer radical polymerization . *Chem Rev* 2001;101:2921 – 2990.
- (220) Kim CK, Ghosh P, Pagliuca C, Zhu Z, Menichetti S, Rotello VM. Entrapment of hydrophobic drugs in nanoparticle monolayers with efficient release into cancer cells. *J Am Chem Soc* 2009;131:11360 – 1361.
- (221) Kim BS, Park SW, Hammond PT. Hydrogen-bonding layer-by-layer-assembled biodegradable polymeric micelles as drug delivery vehicles from surfaces. *ACS Nano* 2008;2:386 – 392.
- (222) Musumeci T, Ventura CA, Giannone I, Ruozi B, Montenegro L, Pignatello R, et al. PLA/PLGA nanoparticles for sustained release of docetaxel. *Int J Pharm* 2006;325:172 – 179.
- (223) Tong R, Cheng JJ. Ring-opening polymerization mediated-controlled formulation of polylactide nanoparticles. *J Am Chem Soc* 2009;131:4744 – 4754.
- (224) Tong R, Cheng JJ. Drug-initiated, controlled ring-opening polymerization for the synthesis of polymer-drug conjugates. *Macromolecules* 2012;45:2225 – 2232.
- (225) Yin Q, Tong R, Xu Y, Baek K, Dobrucki LW, Fan TM, et al. Drug-initiated ring-opening polymerization of O-carboxyanhydrides for the preparation of anticancer drug-poly(O-carboxyanhydride) nanoconjugates. *Bioacromolecules* 2013;14(3):920 – 929.
- (226) Kuntsche J, Westesen K, Drechsler M, Koch MJH, Bunjes H. Supercooled smectic nanoparticles: A potential novel carrier system for poorly water soluble drugs. *Pharm Res* 2004;21(10):1834 – 1843.

- (227) Galindo-Rodriguez SA, Puel F, Briancon S, Allemann E, Doelker E, Fessi H. Comparative scale-up of three methods for producing ibuprofen-loaded nanoparticles. *Eur J Pharm Sci* 2005;25(4-5):357 – 367.
- (228) Jiang B, Hu L, Gao C, Shen J. Crosslinked polysaccharide nanocapsules: Preparation and drug release properties. *Acta Biomaterialia Journals* 2005;2:9–18.
- (229) Quintanar-Guerrero D, Allémann E, Fessi H, Doelker E. Preparation techniques and mechanisms of formation of biodegradable nanoparticles from preformed polymers. *Drug Dev Ind Pharm* 1998;24(12):1113 - 1128.
- (230) Jiang B., Hu L., Gao C., Shen J. Ibuprofen-loaded nanoparticles prepared by a co-precipitation method and their release properties. *International Journal of Pharmaceutics* 2005a;304:220–230.
- (231) Quintanar-Guerrero D, Tamayo-Esquivel D, Ganem-Quintanar A, Allémann E, Doekler E. Adaptation and optimization of of the emulsification-diffusion technique to prepare lipidic nanospheres . *Eur J Pharm Sci* 2005;26:211 – 218.
- (232) Wu H, White M, Khan MA. Quality-by-Design (QbD): An integrated process analytical technology (PAT) approach for a dynamic pharmaceutical co-precipitation process characterization and process design space development. *Int J Pharm* 2011;405:63 – 78.
- (233) International Conference on Harmonization. : Pharmaceutical Quality System (2007). ICH Q10 2007;Switzerland, Geneva.
- (234) International Conference on Harmonization. Pharmaceutical Development Revision 1. ICH Q8 (R1) November 1 2007;Revision 1, Step 3(Draft, Geneva).
- (235) International Conference on Harmonization: Quality Risk Management. ICH Q9 November 9 2005;Step 4(Geneva).
- (236) Crcarevska MS, Dimitrovska A, Sibinovska N, Mladenovska K, Raicki RS, Dodov MG. Implimentation of quality by design principles in the development of microsponges as drug delivery carriers: identification and optimization of critical factors using multivariate statistical analyses and design of experiment studies . *Int J Pharm* 2015;489:58 – 72.
- (237) Visser JC, Dohmen WMC, Hinrichs WLJ, Breikreutz J, Frijlink HW, Woerdenbag HJ. Quality by design approach for optimizing the formulation and physical properties of extemporaneously prepared orodispersible films. *Int J Pharm* 2015;485:70 – 76.
- (238) Visser JC, Woerdenbag HJ, Crediet S, Gerrits E, Lesschen MA, Hinrichs WLJ, et al. Orodispersible films in individualized pharmacotherapy: the development of a formulation for pharmacy preparations . *Int J Pharm* 2015;478:155 – 163.
- (239) Choi J, Yoo JY, Kwak H, Nam BU, Lee J. Role of polymeric stabilizers for drug nanocrystal dispersions . *Curr Appl Phys* 2005;5(5):472 – 474.
- (240) Cho EC, Zhang Q, Xia Y. The effect of sedimentation and diffusion on cellular uptake of gold nanoparticles. *Nat Nanotechnol* 2011;6:385 – 391.
- (241) Kim T, Lee K, Gong MS, Joo SW. Control of gold nanoparticle aggregates by manipulation of interparticle interaction. *Langmuir* 2005;21:9524 – 9528.
- (242) Muller RH, Jacobs C, Kayser O. Nanosuspensions as particulate drug formulations in therapy rationale for development and what we can expect for the future. *Adv Drug Deliv Rev* 2001;47:3 – 19.