

A Review of Model Predictive Control Strategies for Matrix Converters

Mahyar Khosravi¹, Masoume Amirbande¹, Davood A. Khaburi¹, Marco Rivera^{2*}, Jose Riveros², Jose Rodriguez³, Abolfazl Vahedi¹, Patrick Wheeler⁴

¹Electrical Engineering Department, Iran University of Science and Technology (IUST), Tehran, Iran

²Department of Electromechanical and Energy Conversion, Universidad de Talca, Talca, Chile

³Faculty of Engineering, Universidad Andres Bello, Santiago, Chile

⁴Electrical and Electronics Department, The University of Nottingham, Nottingham, UK

* marcoriv@utalca.cl

Abstract: Matrix converters are a well-known class of direct AC-AC power converter topologies that can be used in applications in which compact volume and low weight are necessary. For good performance, special attention should be paid to the control scheme used for these converters. Model predictive control strategy is a promising, straightforward and flexible choice for controlling various different matrix converter topologies. This work provides a comprehensive study and detailed classification of several predictive control methods and techniques, discussing special capabilities they each add to the operation and control scheme for a range of matrix converter topologies. The paper also considers the issues regarding the implementation of model predictive control strategies for matrix converters. This survey and comparison is intended to be a useful guide for solving the related drawbacks of each topology and to enable the application of this control scheme to matrix converters in practical applications.

Nomenclature

v_s	Source voltage	$[v_{sA} \ v_{sB} \ v_{sC}]^T$
i_s	Source current	$[i_{sA} \ i_{sB} \ i_{sC}]^T$
v_i	Input voltage	$[v_A \ v_B \ v_C]^T$
i_i	Input current	$[i_A \ i_B \ i_C]^T$
v_{dc}	DC-link voltage	
i_{dc}	DC-link current	
v_o	Output voltage	$[v_a \ v_b \ v_c]^T$
i_o	Output current	$[i_a \ i_b \ i_c]^T$
v_o^*	Output voltage reference	$[v_a^* \ v_b^* \ v_c^*]^T$
i_s^*	Source current reference	$[i_{sA}^* \ i_{sB}^* \ i_{sC}^*]^T$
i_o^*	Output current reference	$[i_a^* \ i_b^* \ i_c^*]^T$
R_f	Input filter resistance	
L_f	Input filter inductance	
C_f	Input filter capacitance	
L_o	Load inductance	
R_o	Load resistance	

1. Introduction

The Matrix Converter (MC) is a power converter topology in which an AC-source is directly connected to an

AC-load without the presence of bulky energy storage devices. Hence, this configuration is appropriate for applications in which the converter volume and weight must be minimized. The MC topology presents many advantages over the conventional cascaded rectifier-inverter structure such as controllable power factor at the source side, sinusoidal waveforms at the load and input side with low harmonic content and natural, bi-directional power transfer [1].

A considerable number of modulation and control techniques have been proposed for MCs in the literature. As stated in [2], the first modulation methods were Venturini [3] and Roy's [4] strategies, which appeared to involve complex mathematical approaches. However, the Pulse-Width Modulation (PWM) strategy is one of the most straightforward methods used for matrix converters [5]-[6]. Also, the Space Vector Modulation (SVM) [7]-[8] and Direct Torque Control (DTC) [9]-[10] present good performance when applied to electrical motor drives in the industrial applications. However, these methods suffer from relative complexity.

Other methods for controlling matrix converters include direct power control [11]-[12], fuzzy control [13]-[15], neural networks [16]-[17] and genetic algorithms [18]-[19]. Some leading strategies like Model Predictive Control (MPC) have been newly proposed in order to simplify the control of MCs and provide fast and satisfactory performance in both transient and steady states [20]-[46]. For establishing a straightforward, intuitive and flexible control strategy, this last method considers the nonlinear discrete nature of power electronic circuits and drives. At each sampling instant k , this method employs a mathematical model of the system to predict its behavior at the upcoming sample time. Then, a predefined cost function based on the desired control objectives is defined to select the optimal switching vector.

One notable advantage of MPC is the relative simplicity of its control concept compared to the traditional complex and non-intuitive 3-D modulation strategies that have a considerable number of existing switching vectors. [47] Compares the Fuzzy Logic Control (FLC) and Finite Set - Model Predictive Control (FS-MPC) methods, and the results show that the FS-MPC dynamic response is slightly better than that of the FLC. Therefore, MPC offers more advantages than the traditional linear and nonlinear control methods; including the capability to control different objectives at the same time, high controller bandwidth and a shortened control loop cycle time. Fig. 1 summarizes and classifies the most recognized modulation and control methods used for matrix converters. The most well-known MPC variations with their various control objectives are also shown in this figure.

The primary purpose of this work is to provide a comprehensive report of the essential contributions that the MPC scheme makes to various MC configurations including several control objectives implemented using the MPC strategy. The paper is organized such that the most noteworthy capabilities and advantages that MPC contributes to the MC control scheme are well clarified and the issues related to this control approach are easy to understand.

2. Different Predictive Control Variations Applied to MCs

There are several MPC schemes with a variety of control objectives that have been applied to MC topologies in the referenced papers. Fig. 1 depicts the sub-classification of the most popular schemes, i.e. Predictive Current Control (PCC) and Predictive Torque Control (PTC). Other implementations, such as Predictive Voltage Control (PVC) [39], [40], [43]-[44] and Predictive reactive/active Power Control (PPC) [20], [41] can be found in the literature as well, but they are not analysed in detail here. Moreover, other variations have been presented which cannot be directly included in the classifications of Fig.1. For example, the method proposed in [48] substitutes the conventional

cascaded design with only a predictive controller by which the motor speed and currents are regulated, defining an appropriate cost function. In this section, the PCC and PTC schemes and the different control capabilities that they contribute to MC control schemes are reviewed in detail.

2.1. Predictive Current Control (PCC)

The block diagram of the PCC scheme for matrix converters is depicted in Fig. 2. The basic PCC strategy is formulized firstly. In the basic PCC scheme, only the output current is controlled, and arbitrary values are considered as its reference. As the converter and load models should be used in this method for predicting the upcoming amount of the control variable, an uncomplicated load model is considered:

$$\frac{di_o}{dt} = \frac{1}{L_o}V_o - \frac{R_o}{L_o}i_o \quad (1)$$

By discretising (1) using the forward Euler's approximation:

$$i_o(k+1) = \frac{T_s V_o(k+1) + L_o i_o(k)}{L_o + R_o T_s} \quad (2)$$

in which T_s represents the sampling time. A cost function as defined in (3) is used for calculating the difference between the load current references, I_o^* , and their corresponding predicted values, I_p^* :

$$g(k+1) = |i_a^* - i_a^p| + |i_b^* - i_b^p| + |i_c^* - i_c^p| \quad (3)$$

Several capabilities can be added to this basic scheme by including the reactive power minimization term in this cost function and considering special references for the output current or input reactive power. Different modified PCC schemes are listed in TABLE 1 "see Appendix 1". This table

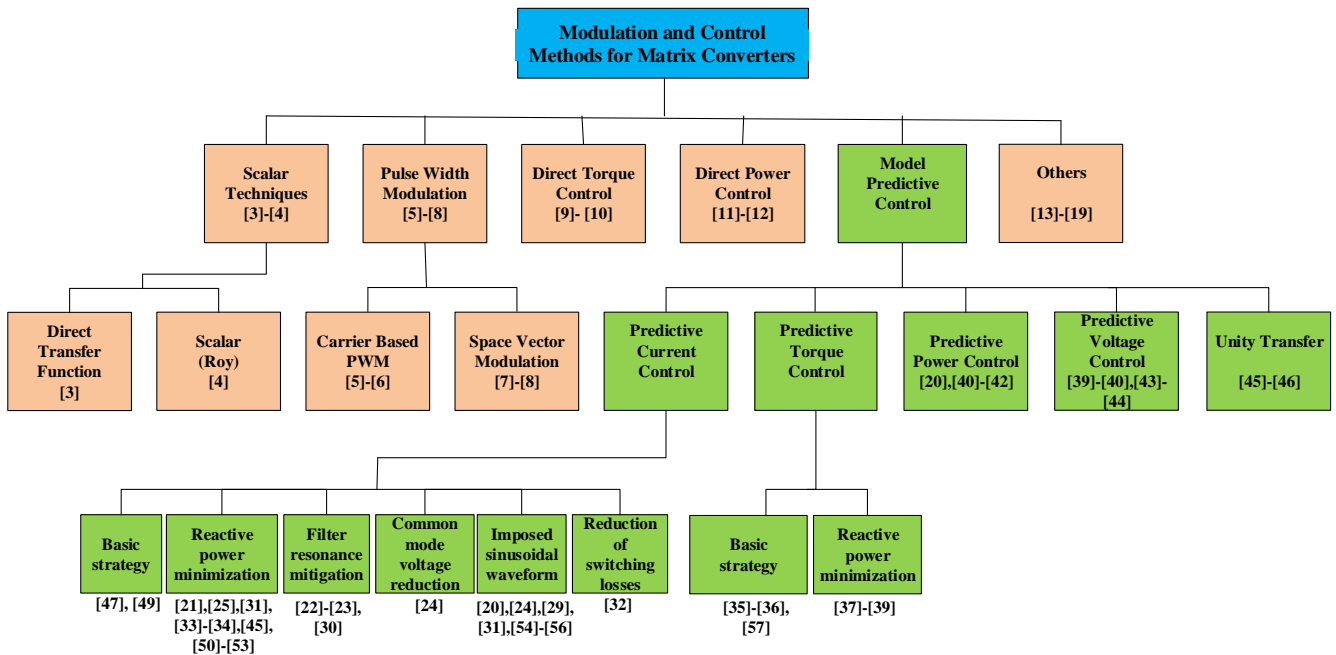

Fig. 1. Classification of different control and modulation strategies for MCs.

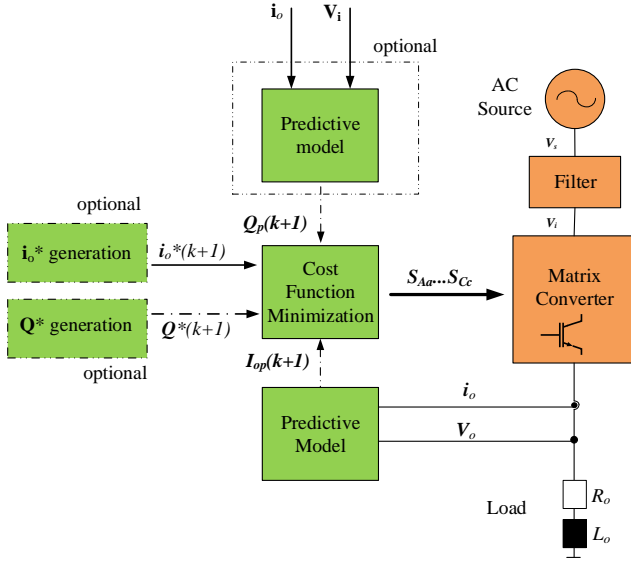

Fig. 2. PCC scheme block diagram for matrix converters.

specifies for each method whether any special values must be applied as the output current and reactive power references. A brief description of each method is provided below.

2.1.1 PCC with reactive power minimization: The input currents will be highly distorted in the basic PCC, which is a major drawback. To improve the source current response and achieve unity power factor, another term is included in the cost function (4) so as to consider the source-side instantaneous reactive power minimization as well [21], [25], [31], [33]-[34], [45], [50]-[53].

$$g(k+1) = \Delta i_o + \gamma_q \Delta q \quad (4)$$

in which Δi_o represents the three-phase load current control term and $\Delta q = |Q^* - (V_{s\alpha} i_{s\beta} - V_{s\beta} i_{s\alpha})|$ is included for input reactive power minimization. Also, γ_q is the weighting factor ([58] presents some guidelines for selecting this value).

2.1.2 PCC with active damping: In the MPC scheme, only one vector may be selected as optimal, and applied for several sampling instances. In this way, an unfixed switching frequency along with a wide spectrum are achieved. This changing frequency, which may be accompanied by source voltage fluctuations, can generate a resonance in the source-side filter that results in a highly distorted input current. Since the source and load sides of the MC are directly connected and have no isolation, this distortion can be transferred to the output current. To overcome this problem, [22]-[23], [30], and [59] propose an input-filter resonance mitigation scheme called active damping, which precludes the drawbacks of passive damping such as the decrease in the overall efficiency. The basic principle of this approach is to employ a virtual resistor at the source side for reducing the harmonic content without affecting the value of the main frequency component. In this strategy, a specific output current reference is generated in order to fulfil the above requirements.

2.1.3 PCC with imposed sinusoidal current reference: In another approach for minimizing the reactive power's instantaneous value, only the main frequency reference waveform is tracked at the input side. According to the results in [20], [24], [29], [31], and [54]-[56], this approach achieves a performance that is superior to that of the instantaneous reactive power minimization method. It results in simultaneously lower THD values at the source and load side currents, attenuating input filter resonance, and hence increasing the life span of the capacitor. Eq. (5) shows the cost function used in this method:

$$g(k+1) = \Delta i_o + \gamma_i \Delta i_s \quad (5)$$

where $\Delta i_s = |i_{sA}^* - i_{sA}^p| + |i_{sB}^* - i_{sB}^p| + |i_{sC}^* - i_{sC}^p|$ is the source current error. The source current reference waveforms and their amplitudes can be determined as follows:

$$\begin{aligned} i_{sA}^* &= I_s \sin(\omega_s t + \theta) \\ i_{sB}^* &= I_s \sin(\omega_s t - \frac{2\pi}{3} + \theta) \\ i_{sC}^* &= I_s \sin(\omega_s t + \frac{2\pi}{3} + \theta) \end{aligned} \quad (6)$$

Here:

$$I_s = \frac{-\lambda V_s + \sqrt{(\lambda V_s)^2 - 4\lambda R_f R_o I_o^2 / \eta}}{-2\lambda R_f} \quad (7)$$

with $\lambda = 1 - 8\pi^2 f_s^2 C_f L_f$. Based on the input reference currents in (6), the required reactive power could be calculated and used in the cost function (5).

A. PCC-based implementation of Field Oriented Control (FOC)

A different PCC approach is presented in [33] for controlling an asynchronous motor with a predictive current control scheme, including the minimization of instantaneous reactive power value. Two stages are present in this method: the first, a predictive phase performing PCC and second, a classical stage providing input reference currents for the first stage based on the Field Oriented Control (FOC) method. In this strategy, the defined cost function is the same as (4). For improving the efficiency of the drive system, two different steps are suggested. These approaches are based on modifying the cost function by adding the number of commutations occurring during transients between the actual switching states, or by directly adding the value of the switching losses [32]. The corresponding modified cost functions are, respectively:

$$g(k+1) = \Delta i_o + \gamma_q \Delta q + \gamma_{sw} n \quad (8)$$

$$g(k+1) = \Delta i_o + \gamma_q \Delta q + \gamma_{sl} \sum_{i=1}^{18} \Delta i_c^{(i)} \Delta v_{ce}^{(i)} \quad (9)$$

Here, n is the number of commutations that occur when applying the optimal vector, and $\Delta i_c^{(i)}$ and $\Delta v_{ce}^{(i)}$ are

respectively the changes in the collector current and collector-emitter voltage of the i^{th} switch. It should be taken into account that 18 is the number of switches in the direct matrix converter topology.

2.2. Predictive Torque Control (PTC)

This control method has been presented in several papers such as [35], [41], and [57], and its implementation diagram is shown in Fig. 3. As in PCC, the PTC scheme includes choosing the optimal actuation among all the possible MC voltage vectors at every sampling period so as to minimize a predefined cost function (g). In order to compute g , the stator flux ψ_s and the electromagnetic torque T_e are predicted for the upcoming sampling time employing a discrete mathematical model of the induction motor. As depicted in Fig. 3, the proportional-integral control scheme is employed to generate the electromagnetic torque reference value T_e^* . For the aforementioned strategy, the differences between the flux and torque predicted and reference values are included in the cost function:

$$g = \Delta T_e(k+1) + \gamma_\psi \Delta \psi(k+1) \quad (10)$$

in which γ_ψ is the flux magnitude weighting factor.

A term similar to that seen in PCC, can be also included in the cost function for reducing the instantaneous value of the reactive power and hence, enhance the converter performance at the source side. Here, the cost function is defined as:

$$g = \Delta T_e(k+1) + \gamma_\psi \Delta \psi(k+1) + \gamma_q \Delta q_s(k+1) \quad (11)$$

Where γ_q and γ_ψ are the weighting factors for the input reactive power and stator flux terms, respectively. Furthermore, in the variation proposed in [60], the corresponding term in (9) is added to (11) in order to achieve higher efficiency than that of the conventional PTC scheme. As concluded in [36]–[39], the PTC strategy provides

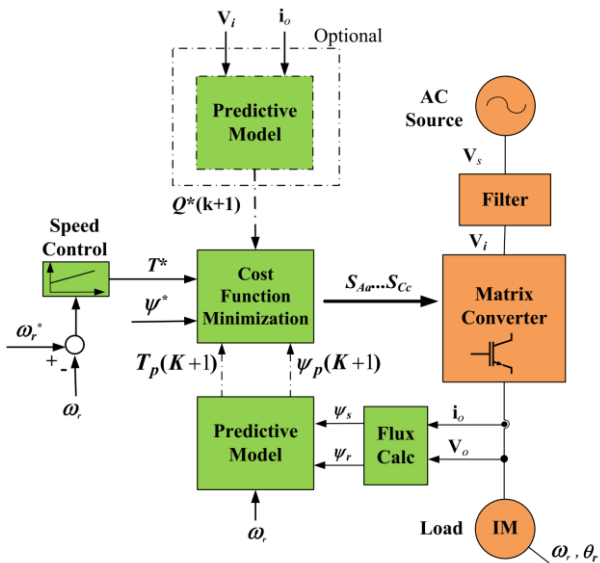

Fig. 3. PTC scheme block diagram for matrix converters.

eminently rapid dynamic behaviour for T_e . In addition, its control is independent of the stator flux. It simultaneously provides unity displacement power factor in both regeneration and motoring conditions with a simple and effective algorithm. All these considerable features make PTC an attractive choice for replacing the Direct Torque Control (DTC) scheme when employing MCs.

3. MPC contributions to different matrix converter configurations

As stated in literature, many different matrix converter structures exist, among which the Direct Matrix Converter (DMC) is the most common. Compared to DMC, the number of switching devices, applications and operation constraints may differ for other structures. Here, a short but comprehensive review is provided about the different MC topologies for which MPC has been implemented. The main focus will be on how MPC improves the operation and control scheme of each topology.

3.1. DMC

Direct Matrix Converter (DMC) is the most common topology to which predictive strategy has been applied. Fig. 4 shows the DMC topology in which a configuration of bidirectional switches is placed between the input source and the load with no extra DC-link device. The source is equipped with a filter in order to eliminate overvoltages that result from the rapid commutation of i_i waveforms and to remove high-order components of i_s [1]. There are two operational constraints for the DMC that should be considered: 1) due to the behavior of the inductive load, its current should not be interrupted, and 2) since a capacitive filter is employed at the source side, a short-circuit of any two input lines must be avoided. Under these constraints, 27 switching states are acceptable and should be evaluated at every sampling instant during the MPC implementation in order to choose a vector that minimizes the cost function.

Several research works, such as [22], [29]–[31], [32]–[33], [37], [38], [40], [43], [45], [50], and [54]–[55], have discussed controlling this converter with an MPC scheme for a wide range of industrial areas including motor drive and grid-connected applications. This control scheme contributes several advantages to the DMC. For instance, the complicated transformations and modulations that are necessary in traditional PWM and SVM methods are eliminated, the

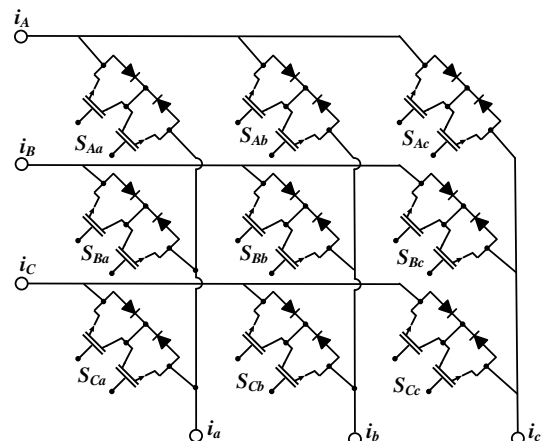

Fig. 4. Power circuit of the DMC configuration.

correct operation of DMC is guaranteed and, unlike in traditional methods, all the available switching states (including rotating vectors) are employed. However, due to the requirement of controlling the both input and output sides of the converter and the presence of a considerable number of switching states, a notable challenge in implementing MPC for the DMC is the weighting factor selection. In [61], an indirect MPC scheme is suggested for separating the control of the input and output variables by considering a fictitious DC-link and thus eliminating the use of weighting factors. Several capacities could be added to this method such as mitigating input filter resonances [62]. MPC has also been applied to some variations of DMC such as Single-Phase MC (SPMC) [43]-[44], its cascaded configurations for high power applications [63] and a three-to-five leg DMC [20]. The main challenge in implementing MPC for the latter converter is the notable computational burden, which is due to the considerable number of applicable voltage vectors (243 different vectors); therefore, appropriate steps should be taken to overcome this problem. Also, a novel and attractive modified topology is a modular multilevel matrix converter; which adds several advantages to the conventional DMC such as simple scalability and superior-quality inputs and outputs. MPC has been applied to this topology in order to extend its range of frequency operation in variable speed drives [64].

3.2. Indirect Matrix Converter (IMC) and other variations

Fig. 5 shows the indirect matrix converter configuration as another MC topology. Despite the fact that its modulation and commutation patterns are simpler than those of DMC, the main challenge here is assuring a non-negative voltage value at the virtual DC-link while at the same time, achieving an input unity Displacement Power Factor (DPF). The MPC scheme has also been applied to this topology in several papers including [14], [23]-[26], [28], [34], [36], [49], and [51], which cover a variety of areas such as shunt active power filters, renewable energy applications and motor drives in aerospace and military applications. Among various control objectives considered in these papers are resonance mitigation at the source filter [23], [25], [28], tracking output reference currents, and obtaining nearly sinusoidal current waveforms at the input line (thus eliminating the attenuation caused by the load nonlinearity) [51]. The rectification stage generates nine voltage vectors while the inversion stage generates eight, resulting in 72 valid switching states for this converter. Since only positive DC-link voltage values are permitted, the valid switching states are reduced to 24, all of which must be examined in the defined cost function at every sample time. Additionally, by appropriately synchronizing the vector changes of the input side with the application of zero states at the inversion stage, the MPC scheme inherently achieves soft switching.

As mentioned in [65]-[66], there are different modified IMC configurations with a lower number of semiconductor devices, and thus existing switching vectors, that are derived from the conventional IMC for specific applications. MPC has also been implemented in some of these topologies including a Sparse Matrix Converter (SMC) (Fig. 6) [21], topologies with more semiconductor devices such as IMC with 4 [27] and 6 legs [35], and a Hybrid IMC (HIMC) (Fig. 7) [46]. SMC requires the generation of a superlative voltage value at the virtual DC-link, the retention

of sinusoidal current waveforms and unity DPF at the input side as well as the synchronization of the rectifier and inverter switches. The method proposed in [21] combines MPC with Space Vector Pulse Width Modulation (SVPWM) to achieve a fixed switching frequency performance. Since MPC is only responsible for controlling the load currents, only eight switching states need to be considered and checked. Next, the selected switching state provides a reference waveform, which is then fed to the modulation subsystem. In this way, the input power factor value approaches unity and the reference waveform is well tracked.

In [67]-[69], the MPC scheme is used for a four-Leg IMC. Here, the control goals include regulating the output current and voltage and decreasing the instantaneous reactive power on the input side. Moreover, MPC has been implemented for a dual-output four-leg MC in [70]. Here, two three-phase output currents are independently controlled by easily optimizing a single cost function. This controller results in a low THD output value, and the zero sequence current is also controlled appropriately. In [71], MPC is applied to a modified three-phase, four-leg MC. A four-switch structure

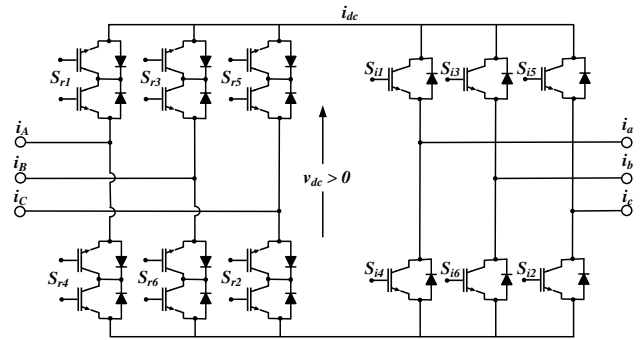

Fig. 5. IMC topology.

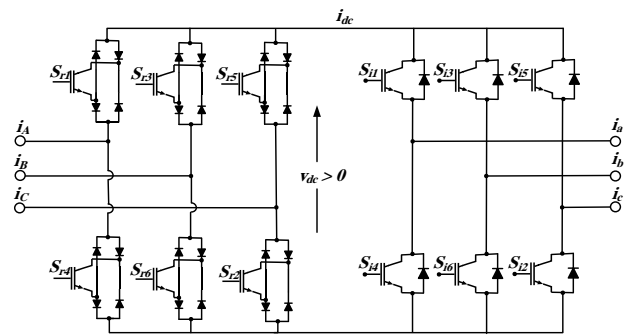

Fig. 6. Sparse matrix converter topology.

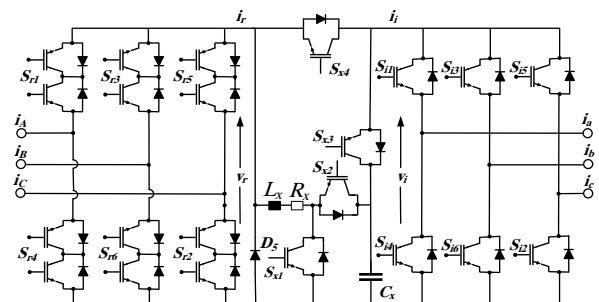

Fig. 7. HIMC topology.

that forms a back-to-back topology has been suggested for generating multilevel variable DC-link voltages. A modified switching method for guaranteeing a positive DC-link voltage has also been suggested for the rectifier stage in order to reduce the computational burden. In [35], MPC is applied to a six-leg IMC feeding a multi-drive system that includes two induction machines. Employing this topology for multi-drive systems results in a significant decrease in their weight and size since it eliminates the need to use a different converter for each machine. The main issue here is the increase of the valid switching states that need to be considered in the optimization algorithm at every sampling time. In order for MPC to achieve a satisfactory behavior, the sampling period should obviously be as small as possible. On the other hand, decreasing the sampling frequency is necessary in order to enable the algorithm to evaluate all of the valid vectors in each sample. To overcome this conflict, some recent investigations have considered some kinds of redundancies for the topology so as to decrease the number of vectors that must be evaluated. Moreover, several works on IMC-derived circuits reclassify the switching vectors of the rectification stage based on the fact that the highest voltage value is required at the virtual DC-link in each moment; and thus decreasing the total number of evaluated switching states by a third [72].

It is common knowledge that a major drawback of the matrix converter topology is its limited output voltage value (86% of the input). The authors of [46] propose a hybrid IMC (Fig. 7), which adds an auxiliary voltage source to the DC-link that enables the unity voltage transfer ratio to be achieved even with the presence of intense fluctuations in the input voltage. They also apply an MPC scheme to the additional source. Here, the proportional-integral control scheme generates the reference waveform for the current, and the MPC strategy feeds the PWM block with an appropriate duty cycle value. The scheme proposed in this reference ensures that the power transfer is balanced and the voltage ratio reaches unity. Another approach for overcoming this problem is to incorporate the over-modulation concept to the MPC scheme [73]. This method, which is implemented by using adjustable weighting factors, achieves a voltage transfer ratio of more than 98% for a variety of output frequencies. This method provides a better performance regarding the control of inputs and outputs than the over-modulation DSVM applied to MCs.

4. Limitations and drawbacks of the MPC scheme applied to MCs

Although it has been proven that different variations of MPC are very effective in controlling MCs, these methods have some limitations and weaknesses. The main ones are:

- Variable sampling frequency.
- Relatively high computational burden.

To eliminate the abovementioned problems, some solutions are suggested in the literature. After a short discussion on the origin of each issue, the proposed solutions are discussed in this section.

4.1. Variable switching frequency

The unfixed switching frequency issue of the MPC strategy is due to the absence of a modulator. In other words,

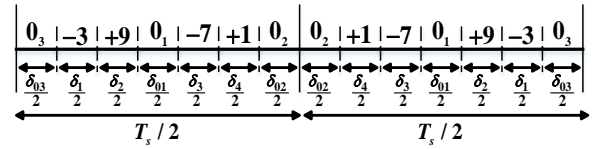

Fig. 8. Double-sided switching pattern used in [77].

since only a single voltage vector is chosen and applied in each sample, the switching frequency varies and considerable ripple components may be generated. Different strategies are proposed for solving this problem. For example, the Discrete Space Vector Modulation (DSVM) strategy has been combined with predictive control by introducing some virtual vectors generated by an external modulator [74]. In [75], only the MPC scheme is used instead of PI controllers, and a conventional modulator is also employed. Furthermore, a method is suggested in [76] based on the low-frequency components of the predictive strategy's discrete outputs. However, it should be noted that the aforementioned approaches are not as intuitive and simple as the conventional predictive strategy, and they entail complex expressions for calculating switching times. The most common approach for fixing the switching frequency is the Modulated Model Predictive Control (M2PC) strategy. In this method, the features of SVM and conventional predictive strategies are combined and, much like in the SVM method, a sequence of voltage vectors is applied in each sample. Similar to the predictive strategy, the best vector sequence and also the duty cycle of each vector in this sequence are determined by a predefined cost function. In this case, the vector that results in lowest value of the cost function has the highest application time. This method has been used in several references. For example, in [77], the double-sided switching pattern is considered with four active- and three zero-voltage vectors in each sequence. Fig. 8 depicts the principles of this scheme. Each vector's duty cycle can be determined by the aforementioned explanation and the equations in [77]. This strategy has been successfully applied to indirect matrix converters [78]-[79], direct matrix converters connected to an induction motor [80], and to DFIG [81]-[82].

4.2. High Computational Burden

As there are numerous control objectives and switching states in MCs, the computational burden of implementing MPC for this converter is noteworthy. However, Due to parallel process ability of FPGAs, the execution time for multiple control objectives could be kept almost constant by implementing MPC in these devices. This approach provides a cost-effective solution for reducing the computational burden [83].

Moreover, several strategies are suggested for decreasing the number of possible switching states. In [84], an algorithm is proposed that preselects the switching states by evaluating the sectors of the input current and output voltage vectors. In this approach, only 11 states are evaluated, and the implementation of MPC with a long prediction horizon becomes possible. In addition, reduction of the sampling period is made possible by decrease of the computational burden, which further improves the control objectives' behavior. In [85], another method is proposed; which decreases the computational burden by avoiding

current prediction and further reducing the candidate states. This approach requires just 10 reactive power predictions and 10 cost function evaluations during each sampling time. Reference [86] proposes a similar approach. Here, the candidate states are reduced by using two predefined look-up tables. These look-up tables are formed according to the sign of torque deviation and the positions of the input voltage and stator flux vectors.

5. Practical and industrial applications

Although MPC has been implemented for different MC topologies, and the benefits and advantages are clear, its industrial applications have not been widely addressed and reported in the literature. Some reasons could be the complexity of the model-based optimization and the computational burden, which requires employing relatively powerful and expensive microprocessors. However, the MPC scheme can provide additional functionalities such as open-switch fault diagnosis, which can be an advantage in certain industrial applications. In [87], a fault identification method that includes two stages and is executed without additional voltage sensors is proposed. In the initial stage, detection of the defective leg is done by comparing reference and estimated values of load voltages. The load voltage reference waveform is acquired using the source voltage and the switching vectors. Next, the location of the defective device is determined by identifying the defective switching vector legs. In [88], fault identification is done by monitoring load currents and evaluating the switching state to detect the faulty switch. Since the predictive strategy uses a fixed switching vector during each sample, the identification of the open switch's exact location is certainly easier. Likewise, a fault-tolerant scheme is proposed for the modular multilevel MC in [89]. This paper's main idea is to use MPC in order to determine the reduced 8-branch topology configuration by optimizing branch currents after the fault occurrence.

Several investigations have also been conducted in order to control MCs with MPC in practical applications. [90] Employs MPC to control MCs used as Solid State Transformers (SSTs). Here, two three-to-single-phase matrix converters are connected in cascade in order to achieve a direct, transformerless and bidirectional AC-AC conversion between two AC grids (Fig. 9). This structure provides several benefits such as reduced weight and volume as well as the absence of storage elements. The traditional modulation and control schemes for this structure require

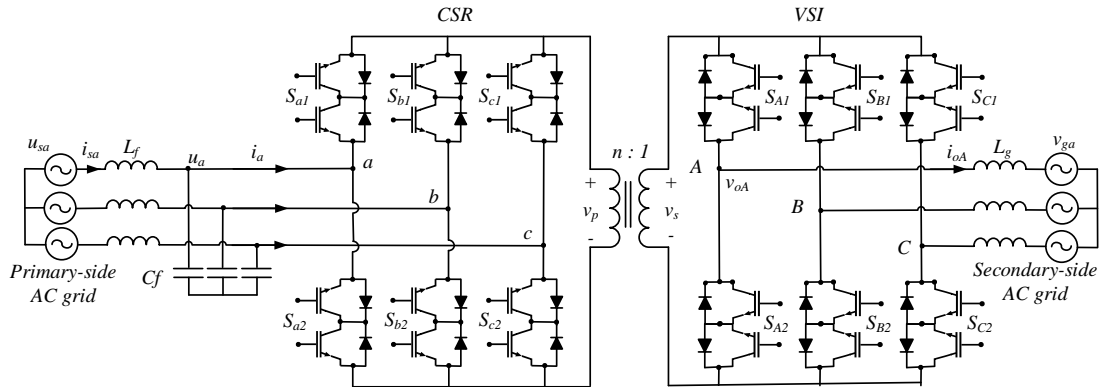

Fig. 9. MC-based SST structure [90]

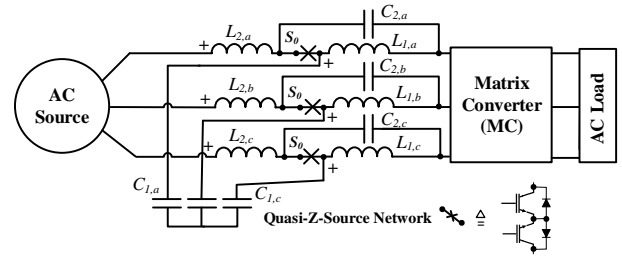

Fig. 10. Quasi-Z-source MC [92]

extra controllers for power management. The MPC is employed in order to manage the power exchange appropriately. It also achieves fast dynamics and voltage matching between the grids without additional computations or control loops [91].

Another area in which MC has been used is Wind Energy Conversion Systems (WECS). A quasi-Z-source MC (Fig. 10) is employed in [92] for this application, and it is controlled in both normal and Low Voltage Ride-Through (LVRT) modes by a modified MPC scheme. In the proposed scheme, the zero states are deliberately inserted into the control pulses. The application of this modified MPC to this topology results in significantly lower grid current ripples and also enhances the LVRT capability of the WECS. In [93], a stability analysis of the above WECS is carried out, and it is shown that the operation will be stable for the whole range.

In [94], MPC is used in order to control a capacitorless MC-based STATCOM (Fig. 11) for compensating lagging power factors. The proposed structure uses MPC to control the input and output currents in such a way that a phase-shift of 180 degree is created between them. By this method, the reactive power is injected to the grid without the need for electrolyte capacitors.

6. Conclusion

This paper provides a comprehensive review about matrix converter various structures and applications which MPC different variations are used to control them. A variety of constraints and challenges related to each topology when it is controlled by the predictive approach have been described in detail. According to the study, each topology has its special requirements and issues, especially when several control goals must be accomplished for a single load or when several motors must be controlled with a single MC. It is revealed that MPC could be considered as an attractive

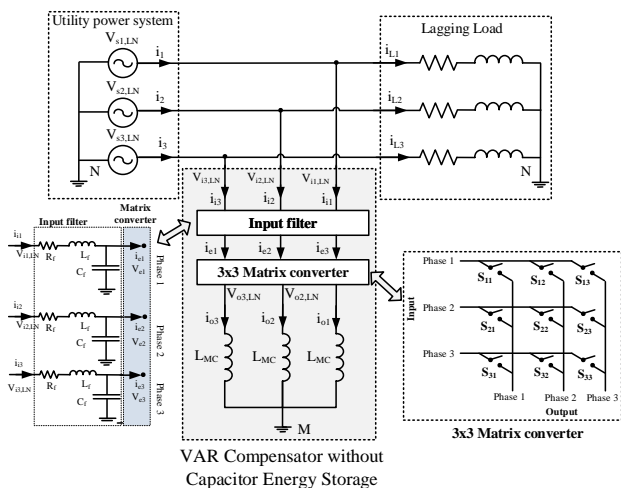

Fig. 11. MC-based STATCOM [94].

solution with notable advantages like flexibility and versatility in the control scheme. However, the implementation of MPC for matrix converters may suffer from some disadvantages such as a high computational burden and a variable switching frequency. Using approaches that avoid an unfixed switching frequency and resonance while also reducing the computational load can further enhance the benefits of MPC. This paper is intended to be used by the researchers in this field to comprehend model predictive control's numerous contributions to matrix converters and to help them solve the issues in future trends.

7. References

[1] Empringham, L., Kolar, J. W., Rodriguez, J., Wheeler, P. W., & Clare, J. C.: 'Technological issues and industrial application of matrix converters: A review', IEEE Transactions on Industrial Electronics, 2013, 60(10), 4260-4271.

[2] Rodriguez, J., Rivera, M., Kolar, J. W., & Wheeler, P. W.: 'A review of control and modulation methods for matrix converters'. IEEE transactions on industrial electronics, 2012, 59(1), 58-70.

[3] Arevalo, S. L., Zanchetta, P., Wheeler, P. W., Trentin, A., & Empringham, L.: 'Control and implementation of a matrix-converter-based AC ground power-supply unit for aircraft servicing'. IEEE Transactions on Industrial Electronics, 2010, 57(6), 2076-2084.

[4] Roy, G., & April, G. E.: 'Cycloconverter operation under a new scalar control algorithm. In Power Electronics Specialists Conference. PESC'89 Record., 20th Annual IEEE, June 1989, pp. 368-375.

[5] Potamianos, P. G., Mitronikas, E. D., & Safacas, A. N.: 'Open-circuit fault diagnosis for matrix converter drives and remedial operation using carrier-based modulation methods'. IEEE Transactions on Industrial Electronics, 2014, 61(1), 531-545.

[6] Nguyen, T. D., & Lee, H. H.: 'Generalized carrier-based PWM method for indirect matrix converters'. In Sustainable

Energy Technologies (ICSET), 2012 IEEE Third International Conference, September 2012, pp. 223-228

[7] Nguyen, H. M., Lee, H. H., & Chun, T. W.: 'Input power factor compensation algorithms using a new direct-SVM method for matrix converter'. IEEE Transactions on Industrial Electronics, 2011, 58(1), 232-243.

[8] Nguyen, T. D., & Lee, H. H.: 'A New SVM Method for an Indirect Matrix Converter With Common-Mode Voltage Reduction'. IEEE Trans. Industrial Informatics, 2014, 10(1), 61-72.

[9] Xiao, D., & Rahman, M. F.: 'A novel sensorless direct torque control for matrix converter-fed ipm synchronous machine'. In Electrical Machines and Systems (ICEMS), International Conference, August 2011, pp. 1-6

[10] Yousefi-Talouki, A., Gholamian, S. A., Yousefi-Talouki, M., Ilka, R., & Radan, A.: 'Harmonic elimination in switching table-based direct torque control of five-phase PMSM using matrix converter'. In Humanities, Science and Engineering Research (SHUSER), 2012 IEEE Symposium, June 2012, pp. 777-782

[11] Monteiro, J., Silva, J. F., Pinto, S. F., & Palma, J.: 'Matrix converter-based unified power-flow controllers: Advanced direct power control method'. IEEE Transactions on Power Delivery, 2011, 26(1), 420-430.

[12] Noguchi, T., & Sato, A.: 'Direct power control based indirect ac to ac power conversion system'. In Power Electronics and Applications'. EPE'09. 13th European Conference, September 2009, pp. 1-8

[13] Wang, X., Guan, Q., & Tian, L.: 'A novel adaptive fuzzy control for output voltage of matrix converter'. In Power Electronics and Motion Control Conference (IPEMC), 2012 7th International, June 2012, Vol. 1, pp. 53-58

[14] Calvillo, C. F., Martell, F., Elizondo, J. L., Avila, A., Macias, M. E., Rivera, M., & Rodriguez, J.: 'Rotor current fuzzy control of a dfig with an indirect matrix converter'. In IECON 2011-37th Annual Conference on IEEE Industrial Electronics Society. November 2011, pp. 4296-4301

[15] Karaca, H., Akkaya, R., & Dogan, H.: 'A novel compensation method based on fuzzy logic control for matrix converter under distorted input voltage conditions'. In Electrical Machines, 2008. ICEM 2008. 18th International Conference, September 2008, pp. 1-5

[16] Sivarani, T. S., Jawhar, S. J., & Kumar, C. A.: 'Novel intelligent hybrid techniques for speed control of electric drives fed by matrix converter'. In Computing, Electronics and Electrical Technologies (ICCEET), International Conference, March 2012, pp. 466-471

[17] Lee, H. H., & Dzung, P. Q.: 'A new artificial neural network controller for direct control method for matrix converters'. In Power Electronics and Drive Systems, 2009. PEDS 2009. International Conference, November 2009, pp. 434-439

- [18] Zanchetta, P., Clare, J. C., Wheeler, P., Katsis, D., Bland, M., & Empringham, L.: 'Control design of a three-phase matrix converter mobile ac power supply using genetic algorithms.' In Power Electronics Specialists Conference, 2005. PESC'05. IEEE 36th, June 2005, pp. 2370-2375
- [19] Zanchetta, P., Sumner, M., Clare, J. C., & Wheeler, P. W.: 'Control of matrix converters for AC power supplies using genetic algorithms'. In Industrial Electronics, 2004 IEEE International Symposium, May 2004, Vol. 2, pp. 1429-1433
- [20] Ahmed, S. M., Iqbal, A., Abu-Rub, H., & Cortes, P.: 'Model predictive control of a three-to-five phase matrix converter'. In Predictive Control of Electrical Drives and Power Electronics (PRECEDE), 2011 Workshop, October 2011, pp. 36-39
- [21] Lee, E., Lee, K. B., Lim, J. S., Lee, Y., & Song, J. H.: 'Predictive current control for a sparse matrix converter'. In Power Electronics and Motion Control Conference (IPEMC), 2012 7th International, June 2012, (Vol. 1, pp. 36-40). IEEE.
- [22] Rivera, M., Correa, P., Rodriguez, J., Lizama, I., Espinoza, J., & Rojas, C.: 'Predictive control with active damping in a direct matrix converter'. In Energy Conversion Congress and Exposition, 2009. ECCE 2009. IEEE, September 2009, pp. 3057-3062
- [23] Rivera, M., Rodriguez, J., Wu, B., Espinoza, J. R., & Rojas, C. A.: 'Current control for an indirect matrix converter with filter resonance mitigation'. IEEE Transactions on Industrial Electronics, 2012, 59(1), 71-79.
- [24] Rivera, M., Rodriguez, J., Espinoza, J., & Wu, B.: Reduction of common-mode voltage in an indirect matrix converter with imposed sinusoidal input/output waveforms. In IECON 2012-38th Annual Conference on IEEE Industrial Electronics Society, October 2012, pp. 6105-6110
- [25] Rivera, M., Rodriguez, J., Espinoza, J. R., & Abu-Rub, H.: 'Instantaneous reactive power minimization and current control for an indirect matrix converter under a distorted ac supply'. IEEE Transactions on Industrial Informatics, 2012, 8(3), 482-490.
- [26] Rivera, M., Rodriguez, J., Espinoza, J. R., Friedli, T., Kolar, J. W., Wilson, A., & Rojas, C. A.: 'Imposed sinusoidal source and load currents for an indirect matrix converter'. IEEE Transactions on Industrial Electronics, 2012, 59(9), 3427-3435.
- [27] Rivera, M., Rodriguez, J., Garcia, C., Pena, R., & Espinoza, J.: 'A simple predictive voltage control method with unity displacement power factor for four-leg indirect matrix converters'. In Power Electronics and Motion Control Conference (EPE/PEMC), 2012 15th International, September 2012, pp. DS2c-5
- [28] Rivera, M., Rodriguez, J., Lopez, M., & Espinoza, J.: 'Control of an induction machine fed by an indirect matrix converter with unity displacement power factor operating with an unbalanced AC-supply'. In Power Electronics and Motion Control Conference (EPE/PEMC), 2012 15th International, September 2012, pp. DS2c-4
- [29] Rivera, M., Rodríguez, J., Wheeler, P. W., Rojas, C. A., Wilson, A., & Espinoza, J. R.: 'Control of a matrix converter with imposed sinusoidal source currents'. IEEE Transactions on Industrial Electronics, 2012, 59(4), 1939-1949.
- [30] Rivera, M., Rojas, C., Rodríguez, J., Wheeler, P., Wu, B., & Espinoza, J. R.: 'Predictive current control with input filter resonance mitigation for a direct matrix converter'. IEEE Transactions on Power Electronics, 2011, 26(10), 2794-2803.
- [31] Rivera, M., Rojas, C., Rodriguez, J., & Espinoza, J.: 'Methods of source current reference generation for predictive control in a direct matrix converter'. IET Power Electronics, 2013, 6(5), 894-901.
- [32] Vargas, R., Ammann, U., & Rodriguez, J.: 'Predictive approach to increase efficiency and reduce switching losses on matrix converters'. IEEE Transactions on Power Electronics, 2009, 24(4), 894-902.
- [33] Vargas, R., Rodríguez, J., Ammann, U., & Wheeler, P. W.: 'Predictive current control of an induction machine fed by a matrix converter with reactive power control'. IEEE Transactions on Industrial Electronics, 2008, 55(12), 4362-4371.
- [34] Correa, P., Rodríguez, J., Rivera, M., Espinoza, J. R., & Kolar, J. W.: 'Predictive control of an indirect matrix converter'. IEEE Transactions on Industrial Electronics, 2009, 56(6), 1847-1853.
- [35] Lopez, M., Rivera, M., Garcia, C., Rodriguez, J., Pena, R., Espinoza, J., & Wheeler, P.: 'Predictive torque control of a multi-drive system fed by a six-leg indirect matrix converter'. In Industrial Technology (ICIT), 2013 IEEE International Conference, February 2013, pp. 1642-1647
- [36] Rodriguez, J., Kolar, J., Espinoza, J., Rivera, M., & Rojas, C.: 'Predictive torque and flux control of an induction machine fed by an indirect matrix converter with reactive power minimization'. In Industrial Electronics (ISIE), 2010 IEEE International Symposium, July 2010, pp. 3177-3183
- [37] Vargas, R., Ammann, U., Hudoffsky, B., Rodriguez, J., & Wheeler, P.: 'Predictive torque control of an induction machine fed by a matrix converter with reactive input power control'. IEEE Transactions on Power Electronics, 2010, 25(6), 1426-1438.
- [38] Vargas, R., Rivera, M., Rodriguez, J., Espinoza, J., & Wheeler, P.: 'Predictive torque control with input PF correction applied to an induction machine fed by a matrix converter'. In Power Electronics Specialists Conference, 2008. PESC 2008. IEEE, June 2008, pp. 9-14
- [39] Zakaria, L., & Barra, K.: 'Predictive direct torque and flux control of an induction motor drive fed by a direct matrix converter with reactive power minimization'. In Networking,

Sensing and Control (ICNSC), 2013 10th IEEE International Conference, April 2013, pp. 34-39

[40] Gambôa, P., Silva, J. F., Pinto, S. F., & Margato, E.: 'Predictive optimal matrix converter control for a dynamic voltage restorer with flywheel energy storage'. In *Industrial Electronics, 2009. IECON'09. 35th Annual Conference of IEEE*, November 2009, pp. 3-5

[41] Ortega, M., Jurado, F., & Carpio, J.: 'Control of indirect matrix converter with bidirectional output stage for micro-turbine'. *IET Power Electronics*, 2012, 5(6), 659-668.

[42] Yusoff, S., De Lillo, L., Zanchetta, P., & Wheeler, P.: 'Predictive Control of a direct AC/AC matrix converter power supply under non-linear load conditions'. In *Power Electronics and Motion Control Conference (EPE/PEMC), 2012 15th International*, September 2012, pp. DS3c-4

[43] Cook, D. J., Catucci, M., Wheeler, P. W., Clare, J. C., Przybyla, J. S., & Richardson, B. R.: 'Development of a predictive controller for use on a direct converter for high-energy physics applications'. *IEEE Transactions on Industrial Electronics*, 2008, 55(12), 4325-4334.

[44] Reyes, E. F., Watson, A. J., Clare, J. C., & Wheeler, P. W.: 'Comparison of predictive control strategies for direct resonant high voltage dc power supply'. *IET*, 2012.

[45] Vargas, R., Rodríguez, J., Rojas, C., & Wheeler, P.: 'Predictive current control applied to a matrix converter: An assessment with the direct transfer function approach'. In *Industrial Technology (ICIT), 2010 IEEE International Conference*, March 2010, pp. 1832-1838

[46] Wijekoon, T., Klumpner, C., Zanchetta, P., & Wheeler, P. W. (2008). Implementation of a hybrid AC-AC direct power converter with unity voltage transfer. *IEEE Transactions on power electronics*, 23(4), 1918-1926.

[47] Calvillo, C. F., Olloqui, A., Martell, F., Elizondo, J. L., Avila, A., Macias, M. E., ... & Rodriguez, J.: 'Comparison of model based predictive control and fuzzy logic control of a dfig with an indirect matrix converter'. In *IECON 2012-38th Annual Conference on IEEE Industrial Electronics Society*, October 2012, pp. 6063-6068

[48] Formentini, A., Trentin, A., Marchesoni, M., Zanchetta, P., & Wheeler, P.: 'Speed finite control set model predictive control of a PMSM fed by matrix converter'. *IEEE Transactions on Industrial Electronics*, 2015, 62(11), 6786-6796.

[49] Rivera, M., Elizondo, J. L., Macias, M. E., Probst, O. M., Micheloud, O. M., Rodriguez, J., & Wilson, A.: 'Model predictive control of a doubly fed induction generator with an indirect matrix converter'. In *IECON 2010-36th Annual Conference on IEEE Industrial Electronics Society*, November 2010, pp. 2959-2965

[50] Rivera, M., Wilson, A., Rojas, C. A., Rodriguez, J., Espinoza, J. R., Wheeler, P. W., & Empringham, L.: 'A comparative assessment of model predictive current control

and space vector modulation in a direct matrix converter'. *IEEE Transactions on Industrial Electronics*, 2013, 60(2), 578-588.

[51] Heris, A. A., Babaei, E., & Hosseini, S. H.: 'A new shunt active power filter based on indirect matrix converter'. In *20th Iranian Conference on Electrical Engineering (ICEE2012)*, May 2012, pp. 581-586

[52] Rivera, M., Vargas, R., Espinoza, J., Rodriguez, J., Wheeler, P., & Silva, C.: 'Current control in matrix converters connected to polluted AC voltage supplies'. In *Power Electronics Specialists Conference, 2008. PESC 2008. IEEE*, June 2008, pp. 412-417

[53] Li, Y., Choi, N. S., Cha, H., & Peng, F. Z.: 'Carrier-based predictive current controlled pulse width modulation for matrix converters'. In *Power Electronics and Motion Control Conference, 2009. IPEMC'09. IEEE 6th International*, May 2009, pp. 1009-1014

[54] Villarroel, F., Espinoza, J., Rojas, C., Molina, C., & Espinosa, E.: 'A multiobjective ranking based finite states model predictive control scheme applied to a direct matrix converter'. In *IECON 2010-36th Annual Conference on IEEE Industrial Electronics Society*, November 2010, pp. 2941-2946

[55] Villarroel, F., Espinoza, J., Rojas, C., Molina, C., & Rodríguez, J.: 'Application of fuzzy decision making to the switching state selection in the predictive control of a direct matrix converter'. In *IECON 2011-37th Annual Conference on IEEE Industrial Electronics Society*, November 2011, pp. 4272-4277

[56] Villarroel, F., Espinoza, J. R., Rojas, C. A., Rodriguez, J., Rivera, M., & Sbarbaro, D.: 'Multiobjective switching state selector for finite-states model predictive control based on fuzzy decision making in a matrix converter'. *IEEE Transactions on Industrial Electronics*, 2013, 60(2), 589-599.

[57] Ortega, C., Arias, A., & Espina, J.: 'Predictive direct torque control of matrix converter fed permanent magnet synchronous machines'. *Asian Journal of Control*, 2014, 16(1), 70-79.

[58] Cortés, P., Kouro, S., Rocca, B. L., Vargas, R., Rodríguez, J., León Galván, J. I., ... & García Franquelo, L.: 'Guidelines for weighting factors design in model predictive control of power converters and drives'. In *International Conference On Industrial Technology (ICIT)*, 1-7. Gippssland, Australia, 2009

[59] Lei, J., Zhou, B., Wei, J., Bian, J., Zhu, Y., Yu, J., & Yang, Y.: 'Predictive power control of matrix converter with active damping function'. *IEEE Transactions on Industrial Electronics*, 2016, 63(7), 4550-4559.

[60] Vargas, R., Rodriguez, J., Rojas, C. A., & Rivera, M.: 'Predictive control of an induction machine fed by a matrix converter with increased efficiency and reduced common-mode voltage'. *IEEE Transactions on Energy Conversion*, 2014, 29(2), 473-485.

- [61] Rivera, M., Di, Z., Zhang, J., & Wheeler, P.: 'Indirect predictive control strategy with mitigation of input filter resonances for a direct matrix converter'. In *Electrical, Electronics Engineering, Information and Communication Technologies (CHILECON), 2017 CHILEAN Conference*, October 2017, pp. 1-6
- [62] Rivera, M., Munoz, J., Wheeler, P., & Xu, L.: 'Indirect model predictive control strategies for a direct matrix converter with mitigation of input filter resonances'. In *2017 IEEE 12th International Conference on Power Electronics and Drive Systems (PEDS)*, December 2017, pp. 748-753
- [63] Kolar, J. W., Friedli, T., Rodriguez, J., & Wheeler, P. W.: 'Review of three-phase PWM AC-AC converter topologies'. *IEEE Transactions on Industrial Electronics*, 2011, 58(11), 4988-5006.
- [64] Fan, B., Wang, K., Wheeler, P., Gu, C., & Li, Y.: 'An optimal full frequency control strategy for the modular multilevel matrix converter based on predictive control'. *IEEE Transactions on Power Electronics*, 2018, 33(8), 6608-6621.
- [65] Friedli, T., & Kolar, J. W.: 'Comprehensive comparison of three-phase ac-ac matrix converter and voltage dc-link back-to-back converter systems'. In *Power Electronics Conference (IPEC), 2010 International*, June 2010, pp. 2789-2798
- [66] Kolar, J. W., Friedli, T., Krismer, F., & Round, S. D.: 'The essence of three-phase AC/AC converter systems'. In *Power Electronics and Motion Control Conference, 2008. EPE-PEMC 2008. 13th*, September 2008, pp. 27-42
- [67] Rivera, M., Contreras, I., Rodriguez, J., Pena, R., & Wheeler, P.: 'A simple current control method with instantaneous reactive power minimization for four-leg indirect matrix converters'. In *Power Electronics and Applications (EPE 2011), Proceedings of the 2011-14th European Conference*, August 2011, pp. 1-9
- [68] Garcia, C., Rivera, M., López, M., Rodriguez, J., Pena, R., Wheeler, P., & Espinoza, J.: 'A simple current control strategy for a four-leg indirect matrix converter'. *algorithms*, 2015, 28, 31.
- [69] Garcia, C. F., Rivera, M. E., Rodriguez, J. R., Wheeler, P. W., & Pena, R. S.: 'Predictive current control with instantaneous reactive power minimization for a four-leg indirect matrix converter'. *IEEE Transactions on Industrial Electronics*. 2017, 64(2), 922-929.
- [70] Gulbudak, O., & Santi, E.: 'Finite Control Set Model Predictive Control of dual-output four-leg Indirect Matrix Converter under unbalanced load and supply conditions. In *Applied Power Electronics Conference and Exposition (APEC), 2016 IEEE*, March 2016, pp. 3248-3254
- [71] Basri, H. M., & Mekhilef, S.: 'Experimental evaluation of model predictive current control for a modified three-level four-leg indirect matrix converter'. *IET Electric Power Applications*, 2017, 12(1), 114-123.
- [72] Rivera, M., Wheeler, P., Olloqui, A., & Khaburi, D. A.: 'A review of predictive control techniques for matrix converters—Part II'. In *Power Electronics and Drive Systems Technologies Conference (PEDSTC), 2016 7th*, February 2016, pp. 589-595
- [73] Zhang, G., Yang, J., Sun, Y., Su, M., Zhu, Q., & Blaabjerg, F.: 'A Predictive-Control-Based Over-Modulation Method for Conventional Matrix Converters'. *IEEE Transactions on Power Electronics*, 2018, 33(4), 3631-3643.
- [74] Vázquez Pérez, S., León Galván, J. I., García Franquelo, L., Carrasco Solís, J. M., Martínez, O., Rodríguez, J., ... & Kouro, S.: 'Model predictive control with constant switching frequency using a discrete space vector modulation with virtual state vectors'. In *International Conference on Industrial Technology*, 1-6. Gippsland, Victoria, Australia, 2009
- [75] Gregor, R., Barrero, F., Toral, S. L., Duran, M. J., Arahal, M. R., Prieto, J., & Mora, J. L.: 'Predictive-space vector PWM current control method for asymmetrical dual three-phase induction motor drives'. *IET Electric Power Applications*, 2010, 4(1), 26-34.
- [76] Ramirez, R. O., Espinoza, J. R., Villarroel, F., Maurelia, E., & Reyes, M. E.: 'A novel hybrid finite control set model predictive control scheme with reduced switching'. *IEEE Transactions on Industrial Electronics*, 2014, 61(11), 5912-5920.
- [77] Vijayagopal, M., Zanchetta, P., Empringham, L., De Lillo, L., Tarisciotti, L., & Wheeler, P.: 'Modulated model predictive current control for direct matrix converter with fixed switching frequency'. In *Power Electronics and Applications (EPE'15 ECCE-Europe), 2015 17th European Conference*, September 2015, pp. 1-10
- [78] Rivera, M., Tarisciotti, L., Wheeler, P., & Zanchetta, P.: 'Predictive control of an indirect matrix converter operating at fixed switching frequency'. In *Power Engineering, Energy and Electrical Drives (POWERENG), 2015 IEEE 5th International Conference*, May 2015, pp. 635-640
- [79] Rivera, M.: 'Predictive control with imposed sinusoidal source and load currents of an indirect matrix converter operating at fixed switching frequency and without weighting factors'. In *Power Engineering, Energy and Electrical Drives (POWERENG), 2015 IEEE 5th International Conference*, May 2015, pp. 641-647
- [80] Vijayagopal, M., Empringham, L., de Lillo, L., Tarisciotti, L., Zanchetta, P., & Wheeler, P.: 'Control of a direct matrix converter induction motor drive with modulated model predictive control'. In *Energy Conversion Congress and Exposition (ECCE), 2015 IEEE*, September 2015, pp. 4315-4321
- [81] Olloqui, A., Elizondo, J. L., Rivera, M., Macías, M. E., Micheloud, O. M., Pena, R., & Wheeler, P.: 'Modulated

- model predictive rotor current control (M²PC) of a DFIG driven by an indirect matrix converter with fixed switching frequency'. In Power Electronics Conference (SPEC), IEEE Annual Southern, December 2016, pp. 1-6
- [82] Vijayagopal, M., Empringham, L., de Lillo, L., Tarisciotti, L., Zanchetta, P., & Wheeler, P.: 'Current control and reactive power minimization of a direct matrix converter induction motor drive with modulated model predictive control'. In Predictive Control of Electrical Drives and Power Electronics (PRECEDE), 2015 IEEE International Symposium, October 2015, pp. 103-108
- [83] Gulbudak, O., & Santi, E.: 'FPGA-Based Model Predictive Controller for Direct Matrix Converter'. IEEE Trans. Industrial Electronics, 2016, 63(7), 4560-4570.
- [84] Dan, H., Zhu, Q., Peng, T., Yao, S., & Wheeler, P.: 'Preselection algorithm based on predictive control for direct matrix converter'. IET Electric Power Applications, 2017, 11(5), 768-775.
- [85] Siami, M., Khaburi, D. A., & Rodriguez, J.: 'Simplified finite control set-model predictive control for matrix converter-fed PMSM drives'. IEEE Transactions on Power Electronics, 2018, 33(3), 2438-2446.
- [86] Siami, M., Khaburi, D. A., Rivera, M., & Rodríguez, J.: 'A computationally efficient lookup table based FCS-MPC for PMSM drives fed by matrix converters'. IEEE Transactions on Industrial Electronics, 2017, 64(10), 7645-7654.
- [87] Dan, H., Peng, T., Su, M., Deng, H., Zhu, Q., Zhao, Z., & Wheeler, P.: 'Error-voltage-based open-switch fault diagnosis strategy for matrix converters with model predictive control method'. IEEE Transactions on Industry Applications, 2017, 53(5), 4603-4612.
- [88] Peng, T., Dan, H., Yang, J., Deng, H., Zhu, Q., Wang, C., ... & Guerrero, J. M.: 'Open-Switch Fault Diagnosis and Fault Tolerant for Matrix Converter With Finite Control Set-Model Predictive Control'. IEEE Trans. Industrial Electronics, 2016, 63(9), 5953-5963.
- [89] Fan, B., Wang, K., Zheng, Z., Xu, L., & Li, Y.: 'Optimized branch current control of modular multilevel matrix converters under branch fault conditions'. IEEE Transactions on Power Electronics, 2018, 33(6), 4578-4583.
- [90] Liu, Y., Wang, W., Liu, Y., & Bayhan, S.: 'Real-time implementation of finite control set model predictive control for matrix converter based solid state transformer'. International Journal of Hydrogen Energy, 2017, 42(28), 17976-17983.
- [91] Liu, Y., Liu, Y., Ge, B., & Abu-Rub, H.: 'Interactive grid interfacing system by matrix-converter based solid state transformer with model predictive control'. IEEE Transactions on Industrial Informatics, 2017
- [92] Alizadeh, M., & Kojori, S. S.: 'Modified predictive control for both normal and LVRT operations of a Quasi-Z-Source Matrix Converter based WECS'. Control Engineering Practice, 2017, 68, 1-14.
- [93] Alizadeh, M., & Kojori, S.: 'Small-signal stability analysis, and predictive control of Z-Source Matrix Converter feeding a PMSG-WECS'. International Journal of Electrical Power & Energy Systems, 2018, 95, 601-616.
- [94] Shadmand, M. B., Mosa, M., Balog, R. S., & Abu-Rub, H.: 'Model predictive control of a capacitorless matrix converter-based STATCOM'. IEEE Journal of Emerging and Selected Topics in Power Electronics, 2017, 5(2), 796-808.

8. Appendices

TABLE 1 Different PCC modifications applied to MCs

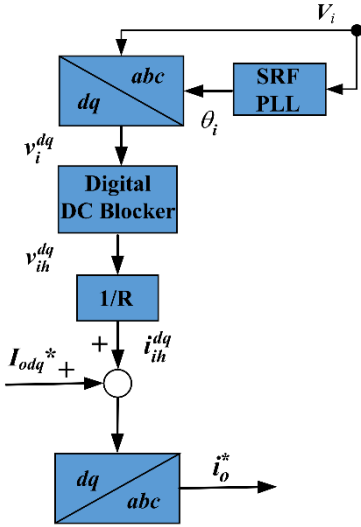
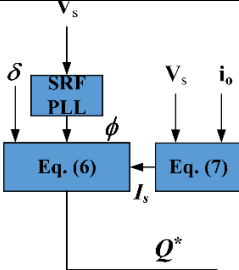
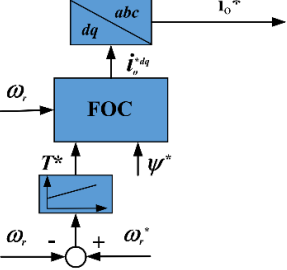
<i>Method</i>	<i>Prediction of input reactive power</i>	<i>Special i_o^* generation scheme</i>	<i>Special Q^* generation scheme</i>
Basic PCC	Not Needed	Not Needed	Not Needed
PCC with Q minimization	Necessary	Not Needed	Not Needed
PCC with active damping	Necessary		Not Needed
PCC with imposed sinusoidal source current	Necessary	Not Needed	
FOC+PCC	Necessary		Not Needed