

THE SHARING OF FLOOD WATERS IN THE KSOURS OF GHARDAÏA AND BERRIANE (ALGERIA) HYDRAULIC STUDY

KHELIFA Ali¹, REMINI Boualem²

*¹Department of Hydraulics, Faculty of Technology, University of Ouargla, Algeria
alikhelifa81@yahoo.com*

*²Department of Water Science and Environment, Faculty of Technology, Blida University 1, Blida
9000, Algeria, reminib@yahoo.fr*

ABSTRACT

The present article deals with two systems of sharing flood waters used in the oases of Ghardaïa and Berriane. Based on bibliographic work, and data collection and investigations performed during the period between 2006 and 2018 near the Ksourian population as the floods are the only source of water for both oases. Ancestral hydraulic systems of sharing and regularizing floods were implemented in both oases. Each hydraulic system is composed of several hydraulic structures (e.g. dams, spillways, galleries, wells) that have been designed taking into considerations the geomorphology and topography of the region. This study compares the two systems and proves that although built 7 centuries ago, both the systems were built with intelligence. They have become parts of the national heritage and must be preserved for future generations.

Keywords: Ghardaïa, Berriane, flood, sharing waters.

1 INTRODUCTION

In dry regions like the Sahara, the rains are rare, but sudden and destructive floods appear in the seasons of autumn and spring. Twice or three times a year the rains can produce a high quantity of water. An important percentage of those drained waters evaporate in the atmosphere while a little quantity of water is drained in the ground to feed the groundwater. According to geological and hydrogeological conditions of a region, the population adapts while implementing necessary devices to catch groundwater. Local people usually build hydraulic systems for several years. Once completed and commissioned, each participant receives their share of water according to their contribution. For example, the ancestral dam designed in the valley of Tiout to collect water was destined to irrigate the gardens of Tiout oasis. For this purpose, the farmers take turns in sharing the water and each has their share of water converted into a number of hours [1]. In the Saoura Valley, the oases are equipped with foggaras that capture the waters of the Grand Erg Occidental (Taghit oases), spring water or groundwater. This water is used and shared among farmers based on an hourly mode [2] [3]. For the foggaras used in the oases of Touat and Gourara to capture groundwater, oasis people use a volumetric sharing system. For this purpose, a whole social and technical organization has been implemented for centuries to deal with groundwater sharing operations [4] [5] [6] [7]. The present study is interested in another ancient ancestral flood control system and the sharing of surface waters that has existed for over 7 centuries in the oases of Ghardaïa and Berriane. How did they manage to achieve this system, and what is the desired purpose of accomplishing it? Has the water in the two systems been divided randomly, or in a measured way? Are the two systems similar or do they differ?

2 METHODS

2.1 Region of Study and Methodology of Work

Our research was conducted in the oases of Ghardaïa and Berriane, two oases located about 600 km southwest of Algiers (Fig. 1). To date, these two oases have evolved into cities, especially Ghardaïa, the capital of the M'zab Valley which is classified as a state according to the administrative division from 1987. The state of Ghardaïa has an area of 86,560 km², of which the communes Ghardaïa and Berriane are the subject of our study. They are characterized by a dry to hyper dry climate. The maximum temperature can reach 50°C during the summer season. However, thanks to the existence of large palm areas, the temperature in the middle of a huge palm forest can go down to 15°C. During the winter period, the temperature drops to 3°C. The average annual rainfall is in the order of 100 mm. However, sudden and devastating floods are irregularly drained by all valleys of Chebka (basket) of M'zab, especially M'zab valleys (Ghardaïa) (Figure 2) and Bellouh (Berriane). People still well remember the last flood of October 1st, 2008 which was drained by the M'zab's valley with an estimated flow of 1200 m³/s. It killed 33 people and caused material and other damage. For more than 7 centuries, the aggressiveness of the valleys in the region has pushed the Mozabites to think about building hydraulic systems able to protect oases against floods and take advantage of these nutrient-laden waters for irrigation and groundwater recharge.

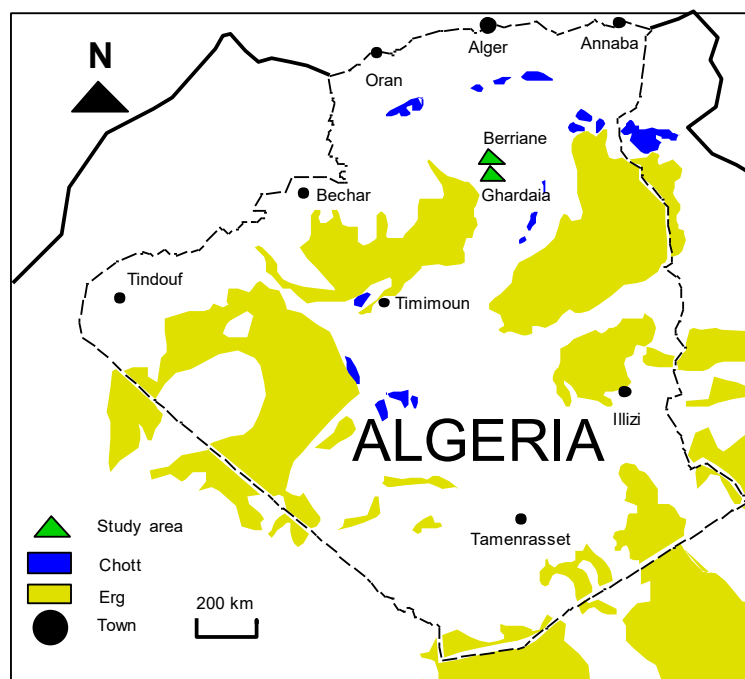

Figure 1. Location of the oases of Ghardaia and Berriane



Figure 2. A view of M'zab's valley

The region of M'zab impressed us by the architecture of its 'ksours' and its floodwater sharing systems. Since 2006, we have carried out two to three missions a year to understand how these engineering systems work. Investigations and discussions with the Ksurian population and Oumana El Ma (water monitoring committee) were conducted at each mission. Investigations were carried out at the hydraulic works. Measurements were made at each hole or spillway. Documents and data were consulted at the libraries, the OPVM, the direction of hydraulics.

2.2 Principle of Watering System

Before the discovery of the deep aquifer, the Mozabites exploited the groundwater for more than 7 centuries. This is the only water reservoir for them. It is filled irregularly since it depends on the infiltrations from two or three floods that occur in the valleys: M'zab, Soudan or Bellouh. Thanks to the well system, the Mozabites irrigate their gardens and feed their homes with water. However, it is the raw flood water containing silts and nutrients that constitutes an indispensable element for the Mozabites to grow palms. In addition to minimizing damage in case of floods, Mozabite-designed hydraulic systems play an important role in sharing flood waters among farmers.

2.3 Ghardaïa Water Sharing System

To date, this system of sharing flood waters has worked perfectly for 7 centuries. It has been renewed several times. The last repairs were carried out after the great flood of 2008 at Tissembath level, and also the underground tunnels. The ancestral Ghardaïa water sharing system operates as follows. In case of floods in Aadhira's valley, the water goes to the valley of Bouchemdjane, then arrives directly to Tissembath (Figure 3) [8]. In case the water level rises faster, the surplus water will flow towards the Bouchen dam [9]. Once the reservoir is filled with water, it feeds the groundwater of the western region of the oasis of Ghardaia. By penetrating the Tissembath work, the water takes the route in the underground canals to reach the alleys between the gardens (Figure 4) [10]. In the times of floods, it plays the role of a channel. In the times of drought, it serves as an alley. Each canal feeds a specified part of gardens. These are equipped with a rectangular opening called Koua (Figure 5). Its width is different from one opening to another according to several parameters: the distance of the garden from the arrival of the underground canal, the surface of the garden, the number of palm trees. When the garden is flooded, the surplus water flows into the M'zab valley.



Figure 3. Tissanbath work



Figure 4. Work Alley / canal between gardens



Figure 5. Opening Koua

In this study we use hydraulic laws to calculate and evaluate the hydraulic parameters of floodwater sharing system. We chose 4 gardens that are fed by one channel (Figure 6). We compare the different quantities of water penetrated in each garden, and make a comparison between them according to the characteristics of the gardens. Then we determine the performance of the ancestral system using hydraulic laws.

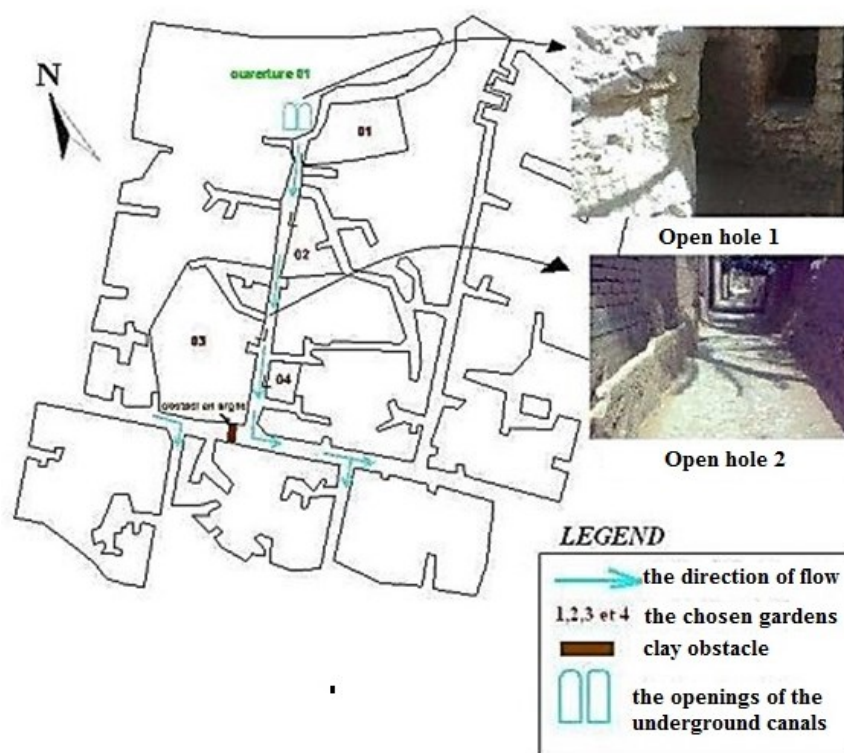

Figure 6. Study zone

2.4 Berriane Water Sharing System

The Berriane water-sharing system is richer in elements (dams, weirs, dykes ...) comparing to that in Ghardaia. The inflow of water occurs in two parts. The northwestern part is fed by several valleys, the most important of which is Zargui Valley. We assume it feeds and recharges all the western part of the palm grove. The northeastern part is the largest and the most important. It is fed by two main valleys: Lemkin which feeds a series of dams, e.g. Ballouh (Figure 7), to break the force of the water flow, and also feeds the palm grove. The Sudan Valley feeds the Sudan dam, the most important structure of the whole Berriane sharing system (Figure 8). It was

renewed during the colonial period in 1958; this dam is intended to recharge more than 60 % of the entire groundwater of the Berriane Valley. The water of these two parts meets in the Mlaga dam (Figure 9).



Figure 7. A view of the Ballouh Dam



Figure 8. A view of the Sudan Dam



Figure 9. Diagram of the operation of the ancestral hydraulic system in oasis of Berriane (Google Earth)

The water sharing system in the northeastern part runs from the Sudan dam, and the western part runs from the Ballouh Dam (Figure 7). Both dams regulate floods. For our study, we chose two gardens located downstream of the Sudan dam. Like in Ghardaia's case, the water sharing starts from Tissenbath which is on an alley that runs parallel to the palm grove. Each group of gardens is fed by a single opening hole (Koua). In this case, the slope of the natural terrain and the intensity of the flood affect the irrigated area. The excess water from the overflow is discharged to other gardens or valleys that are at a lower elevation.

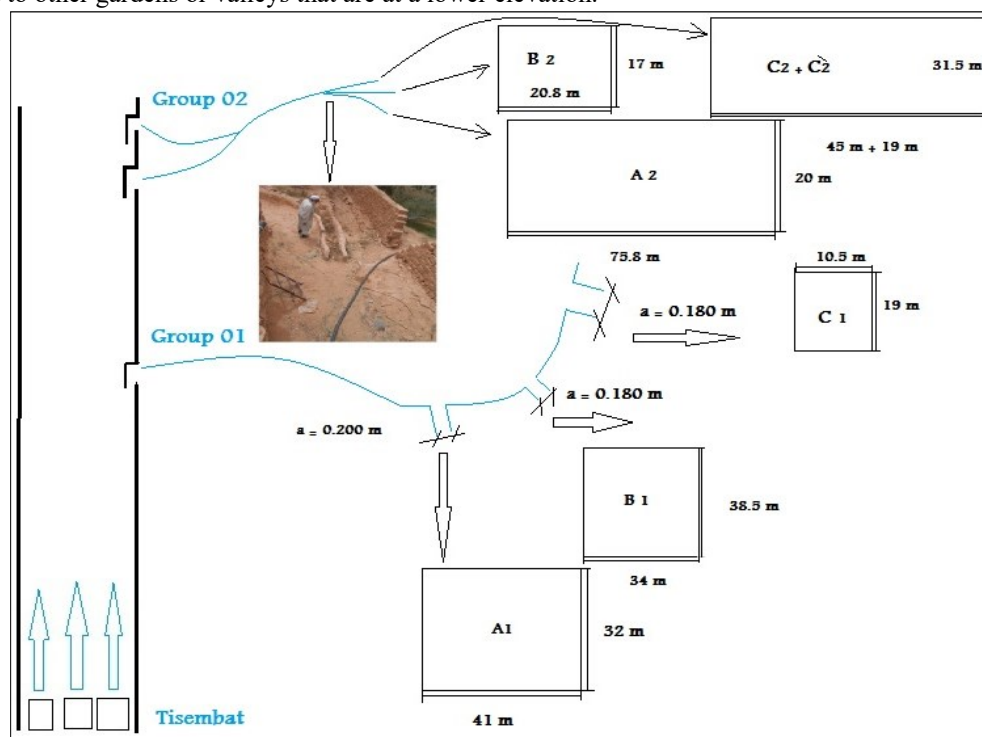

Figure 10. Diagram of the operation of water sharing in the study area

3 RESULTS

3.1 Ghardaïa Water Sharing System

The velocity of free-surface flow in canals between gardens can be determined by the universal Chezy formula [11]: $V = C \sqrt{RI}$ and therefore the flow is determined: $Q = V \times S$

Q - the flow m^3/s

V - the velocity m/s

S - the submerged surface m^2

C - coefficient that depends on the nature of the walls

R - hydraulic radius m

I - the average slope of the channel equals 0.015

With C coefficient of Bazin [11]: $C = \frac{87}{1 + \frac{\delta}{\sqrt{R}}}$

δ - the coefficient value is a function of the nature of the channel. We took $\delta = 1.30$ (Table 1)

R - hydraulic radius (m)

Table 1. Values of the δ [11]

N° 01	0.06	Very smooth walls: smoothed cement, planed wood
N° 02	0.16	Smooth walls
N° 03	0.46	Stone masonry walls
N° 04	0.85	Mixed nature walls: very regular earth sections, stone-lined, ditches
N° 05	1.30	Earthen canals under ordinary conditions
N° 06	1.75	Earthen channels with exceptional resistance: pebble walls

The calculation is done for 3 water levels in this channel (Figures 11 and 12).

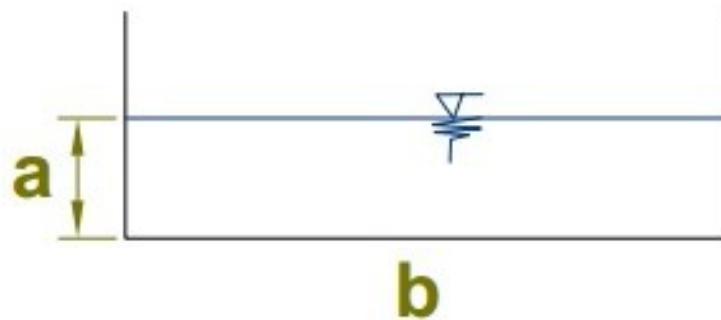

Figure 11. Middle section of the canal

$N_1 = 0.6$ m

* the average measured width is: 2.4 m

$N_2 = 0.4$ m

$N_3 = 0.2$ m

$$R = \frac{ab}{2a+b}$$

$N_1 = 0.6$ m

$R_1 = 0.4$ m

$C_1 = 28.47$

$N_2 = 0.4$ m

$R_2 = 0.3$ m

$C_2 = 25.78$

$N_3 = 0.2$ m

$R_3 = 0.17$ m

$C_3 = 21.01$

So:

N_1

$V_1 = 2.20$ m/s

So the flow

$Q_1 = 3.168$ m³/s

N_2

$V_2 = 1.73$ m/s

So the flow

$Q_2 = 1.161$ m³/s

N_3

$V_3 = 1.065$ m/s

So the flow

$Q_3 = 0.511$ m³/s

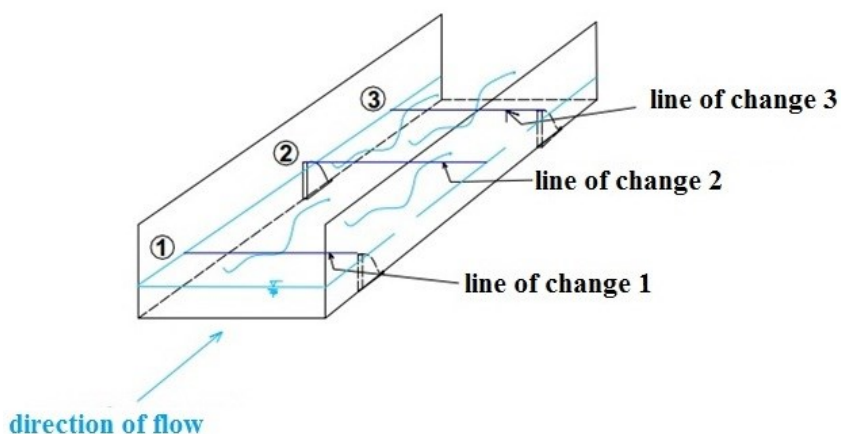

Figure 12. Lines of change

Along the canal, the variation in flow is at each Koua opening (Figure 13). The quantity of water penetrated reduces the flow rate and the velocity. In this case, we get new hydraulic parameters.

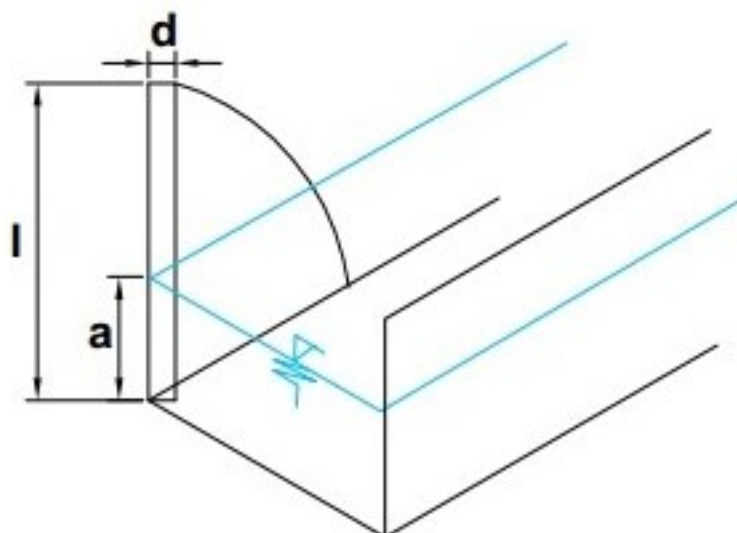

Figure 13. Dimensions of the Koua

Koua 1.

$N_1 = 0.6\text{m}$, the average width is $d = 0.03\text{ m}$.

$$q_{\text{garden } 01} = a \times d \times V \times C$$

A - water level at the orifice ($a \leq l$) m

D - average width of the orifice m

V - the velocity m^2

C - flow coefficient, $C = 0.8$

$$q_{\text{garden } 01} = 0.6 \times 0.03 \times 2.2 \times 0.8$$

$$q_{\text{garden } 01} = 0.031\text{m}^3/\text{s} = 31.6\text{ l/s}$$

After the first orifice, $Q_2 = Q_1 - q_{\text{garden } 01}$

$$Q_2 = 3.1364\text{ m}^3/\text{s}$$

The same calculation is made for the other openings. Figure 14 shows the different flow calculation lines in each point.

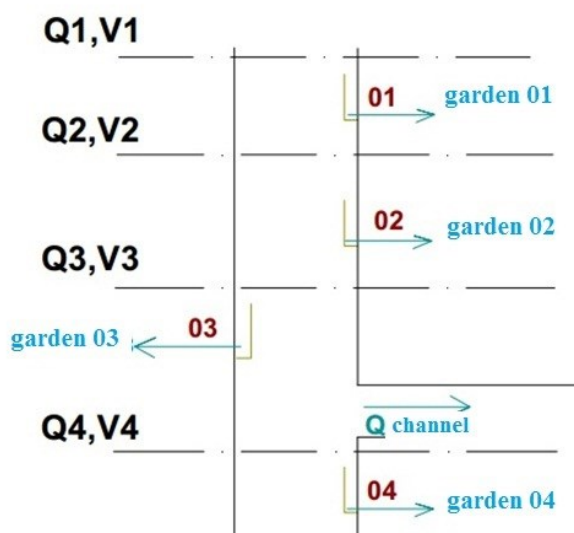

Figure 14. Flow distributions

Level 01.

$$Q_{\text{total infiltrated}} = 0.136 + 0.3656 + 0.008266 + 0.0147 = 0.16552$$

$$(\%)_{g1} = \frac{q_{\text{garden } 1}}{Q_{\text{total infiltrated}}} \times 100 = \frac{0.0316}{0.16552} \times 100 = 19.09\%$$

$$(\%)_{g2} = \frac{q_{\text{garden 1}}}{Q_{\text{total infiltrated}}} \times 100 = \frac{0.3656}{0.16552} \times 100 = 22.08 \%$$

$$(\%)_{g3} = \frac{q_{\text{garden 1}}}{Q_{\text{total infiltrated}}} \times 100 = \frac{0.8266}{0.16552} \times 100 = 49.93 \%$$

$$(\%)_{g4} = \frac{q_{\text{garden 1}}}{Q_{\text{total infiltrated}}} \times 100 = \frac{0.0147}{0.16552} \times 100 = 8.88 \%$$

The same principle will be applied for the other two water levels:

$$N_1 \left\{ \begin{array}{l} (\%)_{g1} = 19.09 \% \\ (\%)_{g2} = 22.08 \% \\ (\%)_{g3} = 49.93 \% \\ (\%)_{g4} = 08.88 \% \end{array} \right. \quad N_2 \left\{ \begin{array}{l} (\%)_{g1} = 19.17 \% \\ (\%)_{g2} = 22.14 \% \\ (\%)_{g3} = 50.02 \% \\ (\%)_{g4} = 08.65 \% \end{array} \right.$$

$$N_3 \left\{ \begin{array}{l} (\%)_{g1} = 19.30 \% \\ (\%)_{g2} = 22.28 \% \\ (\%)_{g3} = 50.24 \% \\ (\%)_{g4} = 8.16 \% \end{array} \right.$$

Traditional calculation method

During our missions in the oasis of Ghardaia, and the discussion with the population and the committee of Oumana El Ma, we obtained little information about the design of hydraulic structures. Only, they confirm that the sharing operation depends on two parameters: number of palm trees and the surface of the garden.

Number of palm trees.

Garden 1: 11 palm trees, $S_{01} = 240 \text{ m}^2$,

Garden 2: 11 palm trees, $S_{02} = 621 \text{ m}^2$,

Garden 3: 23 palm trees, $S_{03} = 136 \text{ m}^2$

Garden 4: 5 palm trees, $S_{04} = 57 \text{ m}^2$

Total: 50 palm trees $S_{\text{total}} = 1054 \text{ m}^2$

$$N \text{ palm trees} \left\{ \begin{array}{l} (\%)_{g1} = \frac{11 \times 100}{50} = 22 \% \\ (\%)_{g2} = 22 \% \\ (\%)_{g3} = 46 \% \\ (\%)_{g4} = 10 \% \end{array} \right.$$

Garden surface

$$\text{Surface} \left\{ \begin{array}{l} (\%)_{g1} = \frac{240 \times 100}{1054} = 22.77 \% \\ (\%)_{g2} = 12.90 \% \\ (\%)_{g3} = 58.91 \% \\ (\%)_{g4} = 5.40 \% \end{array} \right.$$

The different flows calculated for each point, for each level of water are in Table 2.

Table 2. Values and percentages of water shares

Method	Method of verification			Number of palms (%)	Surface (%)
	$N_i = 0.6 \text{ m}$	$N_i = 0.4 \text{ m}$	$N_i = 0.2 \text{ m}$		
(%)garden 1	19.09	19.17	19.3	22	22.77
(%)garden 2	22.08	22.14	22.28	22	12.90
(%)garden 3	49.93	50.02	50.24	46	58.91
(%)garden 4	8.88	8.65	8.16	10	5.4

3.2 Berriane Water Sharing System

At the level of each opening hole of our case study that feeds a group of gardens, there are sub-orifices (openings in walls) that feed each garden. It should be noted that each garden has a surplus water evacuation system (overflow) as in the case of the oasis of Ghardaia.

Group 1 (Koua 1).

This hole feeds 3 gardens with a total area of 2820.5 m². With a water level N = 0.4 m, the calculations with the Chezy formula give the following results:

$$V = C \sqrt{R I}$$

$$C = \frac{87}{1 + \frac{\delta}{\sqrt{R}}}$$

In this case: N = 0.4 m, C = 24.09 and for an average slope I = 0.001 m/m, the width of the Koua for Group 1 is d1 = 0.18 m (Figure 15).

The calculated velocity V is equal to: V = 0.43 m/s.

$$Q_{\text{Group 01}} = a \times d \times V \times C$$

$$Q_{\text{Group 01}} = 0.4 \times 0.18 \times 0.43 \times 0.8$$

$$Q_{\text{Group 01}} = 0.025 \text{ m}^3/\text{s} = 25 \text{ l/s.}$$



Figure 15. Koua of group 1

Sharing waters between group 1 gardens

The sub-orifices are made from cement openings with almost the same width (Figure 16). The garden 1 has a surface of 1313 m² which is fed by a 0.20 m wide opening hole. The nature of the feed channel has an irregular shape with an average width equal to 1 m. At the orifice, we will have $q = V \times S \times C$ with $V = 0.065$ m/s. We have $q_1 = 0.0016$ m³/s = 1.6 l/s. which is fed by an orifice 0.18 m wide. The nature of the feed channel has an irregular shape with an average width equal to 1 m. Before arriving at the orifice, the remaining flow is:

$$q' = Q_{\text{Group 01}} - q$$

$$q' = 0.025 - 0.0016; \quad q' = 0.0234 \text{ m}^3/\text{s}$$

$$V = \frac{q'}{S} \text{ the flow velocity at the level of the 2}^{\text{nd}} \text{ opening } V = 0.0585 \text{ m/s}$$

$$q_2 = V \times S_2 \times C \quad q_2 = 0.0585 \times 0.0081 \times 3.14 \times 0.8$$

$$\text{We have } q_2 = 0.0012 \text{ m}^3/\text{s} = 1.2 \text{ l/s.}$$

For the garden 3 with an area of 342 m², we redo the same calculation; $q_3 = 0.0011$ m³/s = 1.1 l/s.

So $Q_{\text{total}} = q_1 + q_2 + q_3$ $Q_{\text{total}} = 0.0039 \text{ m}^3/\text{s} = 3.9 \text{ l/s}$.

Group 1 $\left\{ \begin{array}{l} (\%)_{g1} = \frac{0.0016}{0.0039} \times 100 = 41.6 \% \\ (\%)_{g2} = 33 \% \\ (\%)_{g3} = 25.4 \% \end{array} \right.$



Figure 16. Koua and its different dimensions

Sharing waters between the gardens of group 2

This group contains 3 gardens. The flow rate of the flow in the main channel is:

$$Q' = Q - Q_{\text{Group 01}}$$

$$Q' = 0.77 \text{ m}^3/\text{s} - 0.025 \text{ m}^3/\text{s} \quad Q' = 0.745 \text{ m}^3/\text{s}$$

$$\text{The velocity is: } V_2 = Q' / S V_2 = 0.45 \text{ m/s}$$

This zone is fed by two successive orifices:

Orifice 1:

$$\text{The flow penetrated into the orifice is: } q_2 = a \times d \times v_2 \times C = 0.010 \text{ m}^3/\text{s}$$

$$Q_2' = Q' - q_2 = 0.745 - 0.010 = 0.735 \text{ m}^3/\text{s}$$

$$V_2' = 0.427 \text{ m/s} \text{ (the flow velocity after the first orifice)}$$

Orifice 2:

$$q_2' = a \times d \times v_2' \times C \quad q_2' = 0.016 \text{ m}^3/\text{s}$$

These two orifices feed the second group of gardens, so:

$$Q_{\text{Group 02}} = q_2 + q_2' \quad Q_{\text{Group 02}} = 0.026 \text{ m}^3/\text{s}$$

In this group there is a sub-orifice that divides the water between them.

$$\text{At sub-system level the velocity is } V = \frac{Q_2'}{S} = \frac{0.026}{1.16 \times 0.1} = 0.22 \text{ m/s}$$

$$\text{For the garden 01 } q_{a1} = V \times S, \quad q_{a1} = 0.098 \text{ m}^3/\text{s}$$

$$q_{b1} = 0.0022 \text{ m}^3/\text{s}$$

$$q_{c1} = 0.010 \text{ m}^3/\text{s}$$

$$Q_{\text{total}} = q_{a1} + q_{b2} + q_{c2} = 0.022 \text{ m}^3/\text{s}$$

Group 02 $\left\{ \begin{array}{l} (\%)_{g1} = \frac{0.0098}{0.022} \times 100 = 44.54 \% \\ (\%)_{g2} = 10 \% \\ (\%)_{g3} = 45.45 \% \end{array} \right.$



Figure 17. Water sharing of Group 2

Traditional calculation method.

On the site, we found that there is a lack of information on the designing of the various structures of this system. According to the local population, several parameters are included in the calculation of water shares, the most used of which are: the surface and position of the garden to the source of the water. It should be noticed that in the oasis of Berriane, the surface of the garden is directly related to the number of palm trees because there are no walls of separation between the gardens. So, we use the surface as the main parameter in the calculation.

Group 1: $S_{g_{01}} = 1312 \text{ m}^2$; $S_{g_{02}} = 342 \text{ m}^2$ et $S_{g_{03}} = 1309 \text{ m}^2$. $S_{\text{Total}} = 2963 \text{ m}^2$

Group 2: $S_{g_{01}} = 1858.5 \text{ m}^2$; $S_{g_{02}} = 353.6 \text{ m}^2$ et $S_{g_{03}} = 1895 \text{ m}^2$. $S_{\text{Total}} = 4107.1 \text{ m}^2$

$$\text{Group 1} \quad \left\{ \begin{array}{l} (\%)_{g1} = \frac{1312}{2963} \times 100 = 44.27 \% \\ (\%)_{g2} = 44.17 \% \\ (\%)_{g3} = 11.54 \% \end{array} \right.$$

$$\text{Group 2} \quad \left\{ \begin{array}{l} (\%)_{g1} = \frac{1858.5}{4107.1} \times 100 = 45.25 \% \\ (\%)_{g2} = 08.60 \% \\ (\%)_{g3} = 46.13 \% \end{array} \right.$$

The results obtained are in Table 3.

Table 3. Values and percentages of water shares.

Groups	Gardens	Verification method (%)	Surface (%)
1	Garden 01 (A ₁)	40.4	44.25
	Garden 02 (B ₁)	30.76	44.17
	Garden 03 (C ₁)	28	11.54
2	Garden 01 (A ₂)	44.54	45.25
	Garden 02 (B ₂)	10	08.60
	Garden 03 (C ₂)	45.45	46.13

4 DISCUSSION

The water catching and sharing system was designed to protect the Ghardaia oasis against floods. However, it is also intended to recharge the groundwater and submerge gardens with sediment-laden waters and nutrients. Our study shows that water shares attributed to a farmer takes in consideration the number of palm trees.

It should be noted that the sharing of waters in the second group is more precise because the nature of the sub-orifices is modified by gabion orifices. According to our calculations, the percentage of each part of water

delivered is homogeneous between the neighbours according to the surface of each garden. In many cases, the quantity of floodwater entering this system is significant and the water reaches high levels (1 m). In this case, the sharing is done precisely. On the site we found some herbs, branches, stones and waste in the main canal and some opening holes and sub-orifices. This directly affects the flow and quantity of water entering each garden. The difference that exists between the two systems: Ghardaïa and Berriane is the presence of the separation walls between the gardens in the oasis of Ghardaïa. In the oasis of Berriane, the surface of the garden is connected directly to the number of palm trees; the surface of the garden is defined as follows: The distance between the palms is 3m. The distance between the last palm and the wall is 1.5 m (Figure 18). The surface of the garden is related directly to the number of palms, there are no dividing walls between the gardens.



Figure 18. Distance between palms in a garden de l'oasis de Berriane

5 CONCLUSION

As we mentioned at the beginning of this article, the two hydraulic systems realized at the level of the oases of Ghardaïa and Berriane consist of several structures: dams, canals, galleries and weirs, and are the work of a genius. Built 7 centuries ago with ancestral rules and rudimentary technical means, these structures today attract the admiration of engineers and technicians. Current hydraulic laws applied on both ancestral systems have given virtually the same results as those applied by the Mozabites. This is only a proof of the genius and knowledge acquired over centuries. Although, these hydraulic systems came into existence through painful long-term work, they have degraded a great deal recently. We argue that it is unacceptable to leave this hydraulic heritage abandoned. It is time for the government to take measures.

REFERENCES

- [1] AIT SAADI, H., B. REMINI and A. FARHI. The ksar of Tiout (Algeria): the mastery of water management and the protection of the environment. *Larhyss Newspaper*. 2015, 2015(24), pp. 243-261.
- [2] REMINI, B. and C. REZOUG. The Saoura foggaras: degradation of hydraulic system millennium case of Beni abbes, Ouakda, Beni ounif and Lahmar (Algeria). *GeoScience Engineering*. 2017, 63, 2, pp. 40-47.
- [3] REMINI, B. and C. REZOUG. Can we abandon a traditional irrigation in the Ouakda oasis (Algeria)? *GeoScience Engineering*. 2018, 64, 1, pp. 23-34.
- [4] REMINI, B. Tadmait's foggara: Without energy, from underground water to the surface of the soil. *Larhyss Journal*. 2017, 32, pp. 301-325.
- [5] REMINI, B., B. ACHOUR and J. ALBERGEL. Timimoun's foggara (Algeria): An heritage in danger. *Arabian Journal of Geosciences*. Springer, 2011, Vol. 4, 3, pp. 495-506.
- [6] REMINI, B., B. ACHOUR and R. KECHAD. The sharing of water in the oases of Timimoun heritage cultural declining. *Larhyss Journal*. 2014, 18, pp. 7-17.
- [7] REMINI, B., B. ACHOUR and R. KECHAD. The foggara: a traditional system of irrigation in arid regions. *GeoScience Engineering*. 2014, 60, 3, pp. 32-39.
- [8] REMINI, B. The foggaras of the oasis of Ghardaia (Algeria): the sharing of flood waters. *Larhyss Journal*. 2018, 36, pp. 157-178.

- [9] REMINI, B. and C. OULED BELKHIR. Cleanup and valuation of waters of the aquifer of M'zab Valley (Algeria). *Journal of Water and Land Development*. 2016, 29, pp. 23-29.
- [10] REMINI, B., B. ACHOUR, C. OULED BELKHIR and D. BABA AMAR. The M'zab foggara: an original technique for collecting the water rising. *Journal of Water and Land Development*. 2012, 16, pp. 49-53.
- [11] CARLIER, M. *General and Applied Hydraulics*. Paris: Eyrolles, 1986.