

In-Use Emissions Testing of Diesel-Driven Buses in Southampton: Is Selective Catalytic Reduction as Effective as Fleet Operators Think?

Sowman, J, Box, S, Wong, A, Grote, M, Laila, DS, Gillam, NG, Cruden, A, Preston, J & Fussey, P

Published PDF deposited in Coventry University's Repository

Original citation:

Sowman, J, Box, S, Wong, A, Grote, M, Laila, DS, Gillam, NG, Cruden, A, Preston, J & Fussey, P 2018, 'In-Use Emissions Testing of Diesel-Driven Buses in Southampton: Is Selective Catalytic Reduction as Effective as Fleet Operators Think?' *IET Intelligent Transport Systems*, vol (in press), pp. (in press)

<https://dx.doi.org/10.1049/iet-its.2017.0173>

DOI 10.1049/iet-its.2017.0173

ISSN 1751-956X

ESSN 1751-9578

Publisher: Institute of Engineering and Technology

This is an open access article published by the IET under the Creative Commons Attribution License (<http://creativecommons.org/licenses/by/3.0/>)

Copyright © and Moral Rights are retained by the author(s) and/ or other copyright owners. A copy can be downloaded for personal non-commercial research or study, without prior permission or charge. This item cannot be reproduced or quoted extensively from without first obtaining permission in writing from the copyright holder(s). The content must not be changed in any way or sold commercially in any format or medium without the formal permission of the copyright holders.

In-use emissions testing of diesel-driven buses in Southampton: is selective catalytic reduction as effective as fleet operators think?

ISSN 1751-956X
 Received on 30th May 2017
 Revised 10th January 2018
 Accepted on 28th January 2018
 doi: 10.1049/iet-its.2017.0173
 www.ietdl.org

Jonathan Sowman¹ ✉, Simon Box², Alan Wong², Matt Grote², Dina S. Laila³, Gus Gillam², Andrew J. Cruden¹, John M. Preston², Peter Fussey⁴

¹Energy Technology Group, Faculty of Engineering and the Environment, University of Southampton, Southampton SO17 1BJ, UK

²Transportation Research Group, Faculty of Engineering and the Environment, University of Southampton, Southampton SO17 1BJ, UK

³School of Mechanical, Aerospace and Automotive Engineering, Coventry University, Coventry CV1 2TL, UK

⁴Engine Control and Calibration, Ricardo Ltd, Shoreham-by-Sea, West Sussex BN43 5FG, UK

✉ E-mail: j.sowman@soton.ac.uk

Abstract: Despite the continuously tightening emissions legislation, urban concentrations of nitrogen oxides (NO_x) remain at harmful levels. Road transport is responsible for a large fraction, wherein diesel engines are the principal culprits. Turbocharged diesel engines have long been preferred in heavy duty applications, due to their torque delivery and low fuel consumption. Fleet operators are under pressure to understand and control the emissions of their vehicles, yet the performance of emissions abatement technology in real-world driving is largely unquantified. The most popular NO_x abatement technology for heavy duty diesel vehicles is selective catalytic reduction. In this work, the authors empirically determine the efficiency of a factory-fitted selective catalytic reduction (SCR) system in real-world driving by instrumenting passenger buses with both a portable emissions measurement system and a custom-built telematics unit to record key parameters from the vehicle diagnostics systems. They find that even in relatively favourable conditions, while there is some improvement due to the use of SCR, the vehicles operate far from the design emissions targets. The archival value of this study is in quantification of real world emissions versus design levels and the factors responsible for the discrepancy, as well as in examination of technologies to reduce this difference.

1 Introduction

Recently, the concentration of nitrogen oxides (NO_x) in urban environments has been of serious concern, since they are harmful to human health. Nitrogen dioxide (NO₂) in particular is responsible for ‘decrements in measures of lung function and lung function growth, increases in respiratory symptoms, asthma prevalence and incidence, cancer incidence, adverse birth outcomes and mortality’ [1]. Research has shown that despite an overall downward trend in NO_x concentrations in London, the NO₂:NO_x ratio is increasing, due to increasing number of diesel vehicles fitted with oxidation catalysts, as well as uptake of catalysed diesel particulate filters (CDPFs) [2].

Road transport is responsible for up to 60% of NO_x emissions in the UK urban environments [3]. In particular, buses have been responsible for a large part of this emissions problem, since not only do they spend their time in densely populated areas, they frequently operate in heavy congestion and necessarily make regular stops. In 2015, for example, nine out of ten transport for London (TfL) buses were diesel. The result of this is that these diesel buses contributed 14.2% of NO_x emissions in central London in that year [4]. Whilst vehicles are certified to emissions standards before approval for use on the road, it is well known that many vehicles which meet these emissions targets during a test cycle in a controlled condition exhibit significantly worse emissions in real world driving, otherwise termed *off-cycle* emissions [5]. Consequently, recent information shows that actual NO_x emissions from diesel vehicles have seen only a minor decrease over the past 15–20 years [6]. The problem is more widespread even beyond diesel engines, with the ever-increasing pressure on fuel economy driving engine manufacturers towards lean-boosted gasoline engines for light duty and passenger vehicles, in which the problem of excess NO_x emissions resurfaces.

By far the most widely adopted technology for abatement of NO_x is the use of selective catalytic reduction (SCR), in which NO_x is converted into nitrogen and water over a catalyst placed in the exhaust system. Being a chemical system, the temperature of the catalyst is of utmost importance in achieving the desired conversion of NO_x in the exhaust stream. However, high thermal efficiency and aggressive heat recovery in modern diesel engines mean that maintaining the catalyst at sufficient temperature to promote NO_x conversion is non-trivial. Compounded by operating in low-speed urban environments, this can lead to a pernicious situation in which NO_x emissions are markedly above design levels. This is one of the key causes of off-cycle emissions being significantly higher than on-cycle, especially in environments where vehicle speed, and thus exhaust temperatures, is low.

New vehicles conforming to the Euro VI standard (since January 2014) demonstrate up to 95% less NO_x emissions compared to Euro V [7]. However, replacing entire bus fleets is infeasible due to budget constraints. As of 2016, just 13% of the TfL franchised bus fleet was Euro VI compliant, despite this standard being in force for >2 years. In fact, the vast majority of the fleet comprises Euro III (22%), IV (18%) and V (40%) vehicles [8]. Due to this relatively slow turnover of vehicles, some authorities have investigated retrofitting of SCR to older vehicles, including TfL, who are targeting Euro III vehicles for this upgrade [7].

In this work, we investigate the off-cycle emissions of Euro V compliant buses in the City of Southampton. The city exceeds the annual limit for NO₂ and is predicted to continue to do so in 2020 [9]. The methodology involves ballasted vehicles operating on their normal schedule, providing emissions data closely approximating real world use. We find that whilst the buses we tested were new and these vehicles are factory fitted with SCR systems, their NO_x

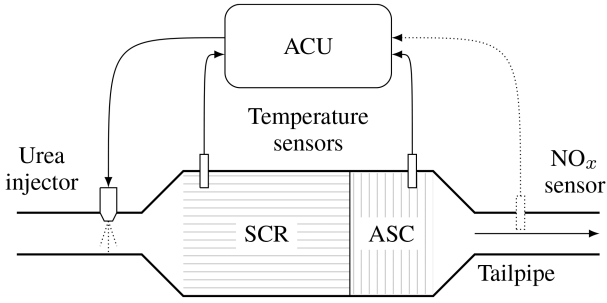
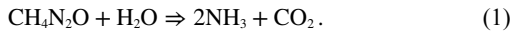

Fig. 1 Schematic of an SCR aftertreatment system, including an ASC and aftertreatment control unit (ACU)

emissions are still above the legislative limit, which is 2.0 g/kWh for Euro V. The extensive data produced by our testing regime provide a basis to understand why this is the case, and additionally allows us to suggest possible mitigation strategies.

2 Review of selective catalytic reduction

Selective catalytic reduction (SCR) is an actively controlled chemical process which converts NO_x into nitrogen and water. A diagram of the SCR catalyst with ammonia slip catalyst (ASC) is shown in Fig. 1. Notice that an NO_x sensor at the inlet to the catalyst is often present in urea SCR systems for the purposes of control. However, it is omitted in this figure since the vehicles tested in this work do not utilise such a sensor. The key reactant is ammonia, which is delivered into the exhaust stream in the form of ammonia solution, which is the product of the hydrolysis of urea due to the heat of the exhaust:



It is necessary that ammonia in the free stream adsorbs onto the catalyst washcoat, since the SCR reactions take place between gaseous NO_x and adsorbed ammonia. The storage of ammonia is an equilibrium reaction:



where * indicates a species existing on the catalytic surface. The double arrow exists since some ammonia can leave the catalyst surface and return to the free stream, if the diffusion gradient favours such movement. An alternative mechanism for ammonia leaving the catalyst is due to some fraction of the ammonia being stored as ammonium ions on the catalyst. These are removed less easily, although a sudden possible in the event of a temperature spike affecting the catalyst. This desorption is a process which the control systems must aim to minimise, as it implies unreacted ammonia exiting the tailpipe, known as *ammonia slip*. The adsorbed ammonia is now available to participate in the SCR reactions, which comprises the standard SCR reaction:

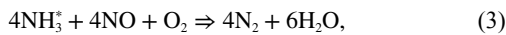

and the fast SCR reaction:

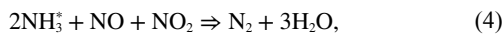

where the former reduces only NO and the latter consumes equal quantities of NO and NO_2 .

The SCR catalyst has a characteristic *light-off* temperature, which marks the temperature boundary between temperature-limited reaction rates and mass transfer limited reactions. The rates for reactions (3) and (4) are given by Arrhenius expressions:

$$r_i = A_i \exp\left(\frac{-B_i}{RT_{\text{mon}}}\right) \quad (5)$$

where A_i and B_i are constants to be determined for each reaction, R is the universal gas constant and T_{mon} is the temperature of the catalyst monolith.

The catalytic washcoat has an ammonia storage capacity which is a material property, and is the maximum possible stored ammonia per unit volume, denoted Φ . In operation, this maximum storage is not achieved, since the reaction rates for (2) determine the storage level. For adsorption, the reaction rate is given as

$$r_{\text{ads}} = k_{\text{ads}} C_{\text{NH}_3} \theta \quad (6)$$

and that for desorption is given as

$$r_{\text{des}} = k_{\text{des}} \exp\left(-\frac{B_{\text{des}}}{RT_{\text{mon}}}(1 - \theta)\right) \theta \quad (7)$$

where θ is defined as the ratio of the current storage per unit volume to the materially determined maximum:

$$\theta = \frac{\phi}{\Phi}. \quad (8)$$

Efficiency of the SCR system is subject to several factors, both chemical and physical. Substrates differ in their adsorption/desorption efficiencies, their reaction efficiencies and their cost. Additionally, physical packaging of the exhaust system can lead to wide variations in the cumulative efficiency of the aftertreatment system. In this work, we do not consider these factors, since we are interested in improving the emissions of existing vehicles without carrying out fundamental changes to the hardware. Instead, we focus solely on efficiency variation as a result of thermal effects. We examine the practical effects of temperature variation on catalyst efficiency, the causes of this variation, and possible improvements via software and retrofitting.

3 Instrumentation

Instrumentation of the vehicles was considered in view of the dual aims of examining off-cycle emissions, and understanding the conditions which lead to suboptimal performance and thus potential mitigation routes. The final configuration comprised two principle elements: direct recording of exhaust emission concentrations of key species, and monitoring of engine control system and vehicle diagnostic parameters.

3.1 Test vehicles

Two Euro V compliant WrightBus StreetLite door forward (DF) vehicles (shown in Fig. 2a) were chosen for testing, since they employ SCR to meet the relevant NO_x emissions limits. This SCR system is factory-fitted and the two buses were <2 years old, with <18 months in operation at the time of the study. They were subject to the servicing schedule recommended by the manufacturer, and it was ensured that no faults were present with the engine or aftertreatment system before testing commenced. The compact engine bay layout and ease of access, as shown in Fig. 2b, permitted simple installation and inspection of the testing equipment.

3.2 Exhaust emissions measurement

The vehicles were fitted with the Horiba OBS-2200 portable emissions measurement system (PEMS). The PEMS unit samples tailpipe gas immediately before its release to the environment, and is capable of recording key emissions including CO, CO_2 , H_2O and NO_x at a sample rate of 10 Hz. Notably, the vehicles were not fitted with NO_x sensors before the SCR, implying that pre-SCR NO_x levels were estimated by the aftertreatment control system based on other measured parameters. This was a key factor in the decision to additionally monitor engine parameters, as discussed below. In this study, the data for the engine out NO_x are obtained by emissions monitoring during periods in which the SCR was non-operational.

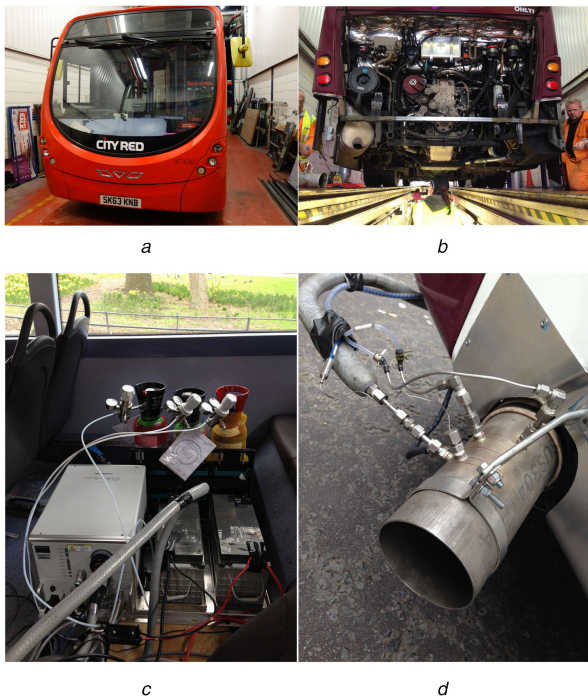

Fig. 2 Vehicles used in this work and the PEMS equipment
(a) Wrightbus Streetlite DF, (b) Engine bay, (c) Horiba OBS-2200, (d) Exhaust sample pipe

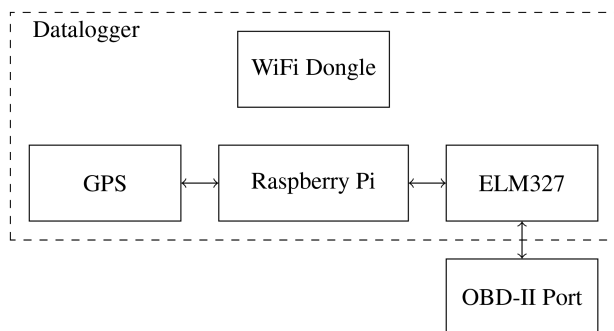

Fig. 3 Schematic of the OBD-II datalogger unit

The in-cabin equipment, comprising the OBS-2200, batteries and gas cylinders, was fitted in place of the rearmost pair of passenger seats. A custom baseplate was used, as shown in Fig. 2c, to retain the PEMS equipment, gas bottles and batteries. The OBS-2200 collects samples of the exhaust gas via a tailpipe attachment shown in Fig. 2d. Additionally, this attachment carries a pair of pitot tubes for flow rate measurement, and a thermocouple to monitor exhaust gas temperature. These data are all fed into the main OBS-2200 unit, which is in turn connected to a laptop computer via Ethernet for setup, calibration and data logging.

The PEMS uses a heated chemiluminescent detector to measure NO_x , as well as having a heated sample pipe to bring a sample of the exhaust gases to the main unit (around 5 m) in order to reduce the likelihood of condensation of water vapour in the exhaust sample, which could damage the analysers. Consequently, the OBS-2200 requires a 24 V power supply capable of up to 40 A. It was considered impractical to draw power from electrical systems on the bus, since the significant electrical load would lead to increased fuel consumption and therefore impact emissions. Correcting for this influence would be extremely difficult and would thus lead to error in the data. Instead, pairs of 12 V 120 Ah sealed lead acid batteries were used, with each pair permitting around 3 h of run time. These can be seen in the bottom right of Fig. 2c. In the rear of this image is three gas canisters and regulators that the OBS-2200 requires: a calibration gas (*span gas*) with known proportions of detectable species, synthetic air and hydrogen (H_2) to power one of the gas analysers.

Table 1 Parameters logged by the telematics unit and their units

Parameter	Units
accelerator pedal position	%
engine torque	%
maximum available torque	%
SCR inlet temperature	$^{\circ}\text{C}$
SCR outlet temperature	$^{\circ}\text{C}$
brake switch	integer
clutch switch	integer
coolant temperature	$^{\circ}\text{C}$
demand torque	%
fuel flow rate	l/h
intake mass air flow rate	kg/h
intake manifold temperature	$^{\circ}\text{C}$
engine load	%
engine speed	rpm
turbocharger intake pressure	kPa
brake power	kW
transmission gear current value	Integer

The exhaust sample pipe, twin pitot tubes and exhaust thermocouple were routed from the exhaust tailpipe attachment into the cabin. This was achieved by removing an access panel in the cabin floor which is usually used for engine maintenance. To prevent ingress of engine and road noise, as well as exhaust fumes from the engine bay, a custom panel was manufactured.

3.3 Engine telematics

Engine operating conditions are used in the onboard engine-out NO_x estimator and the SCR control system. As such, a telematics unit was built to request and record relevant parameters over the OBD-II (on board diagnostics) port. This port provides access to the vehicle's controller area network (CAN) bus, which is used for communication between many electronics components in the vehicle. These data are listed in Table 1. Two desirable parameters for characterising the catalyst would be engine output NO_x (estimated in the case of these vehicles) and urea injected before the SCR catalyst by the aftertreatment control system. However, due to the closed-source nature of the system, it was not possible to retrieve these parameters over the diagnostics bus.

The datalogging unit was based around a Raspberry Pi single-board computer, as shown schematically in Fig. 3 along with the final unit shown in Fig. 4. The vehicles use the SAE J1939 standard for on-board diagnostics, which is one of the modes supported by the ELM Electronics 327 CAN/OBD data capture device, which are cheaply available with USB-Serial connectivity, such that commands can be sent and responses easily parsed by the Raspberry Pi software. A global positioning system (GPS) receiver was also included in the setup, both for real-time clock purposes and to record vehicle latitude, longitude and altitude on the route. This positional data was necessary in order to map emissions to key points on the route, such as inclines and bus stops. A wireless adapter was included such that the datalogger was able to upload the stored data when connectivity was available, specifically at the bus depot where the vehicle was deposited overnight.

The software written for the telematics unit simply requested a pre-defined list of parameters, as shown in Table 1, from the vehicle on a regular basis after ensuring the engine was running. Data was compressed and stored locally until such time as internet connectivity was available, whereafter a separate process managed transmission of the data to a server. The server parsed and inserted the data into the relevant table of a MySQL database, along with metadata such as vehicle identification.

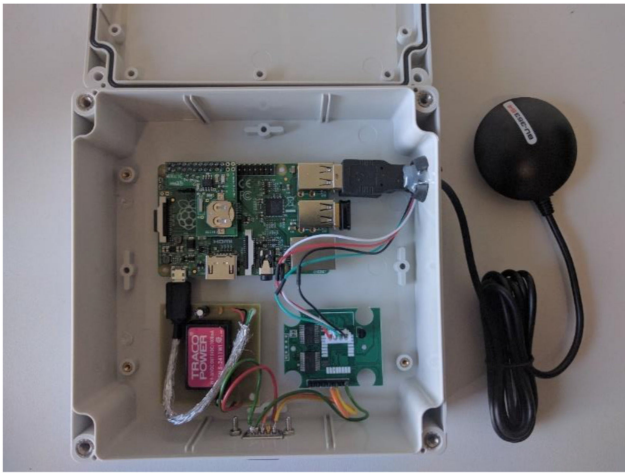

Fig. 4 Telematics unit internal view, showing the Raspberry Pi (internal, top), ELM327 (internal, bottom right), power supply (internal, bottom left) and GPS (external, right)

Table 2 NO_x emissions from the two vehicles on each of the four tests

Vehicle	Test number	Mean exhaust temperature, °C	NO _x , g/kWh
1	1	137	13.5
1	2	151	7.9
1	3	148	13.2
1	4	169	7.4
2	1	212	8.4
2	2	224	6.6
2	3	214	9.0
2	4	220	6.4

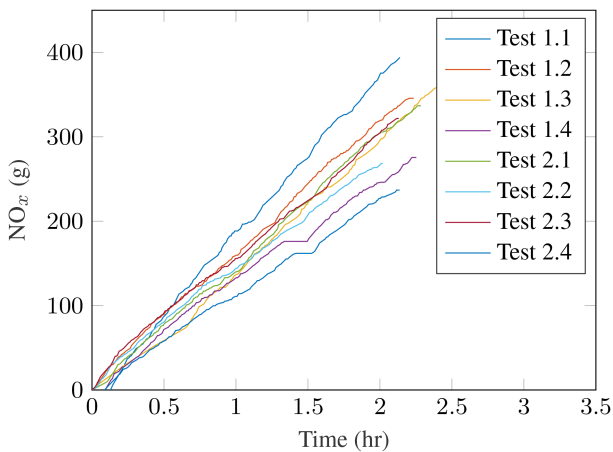

Fig. 5 Cumulative NO_x output during each of the eight tests, where test *x*, *y* refers to vehicle *x*, test number *y* in Table 1

4 Test procedure

Since the aim was to measure real-world emissions, each test comprised the vehicle running its usual route [10] at the normal times of day. The test procedure was also designed to imitate closely the real scenario of the daily buses operation, in terms of the loads, speed, routes, stopping at bus stops, et cetera. The tests were done in two different seasons, the winter and the late spring, to observe the effect of ambient temperature to the SCR operation.

The vehicle was loaded with 700 kg of sand, which along with the test team and measurement equipment, simulated a typically loaded vehicle. Each test comprised 2 h of running the normal route, as driven by a public service vehicle (PSV)-licensed operator appointed driver, and stopping at all usual bus stops. Risk and safety assessments were conducted prior to the start of the

experiments, and before the equipment was set up on board the bus (at the depot) and at the beginning of each trial, a safety briefing was given to all those involved in the tests.

Each vehicle underwent a total of four tests, split over 2 days. On each day, the vehicle left the bus depot at 6.30 a.m. and ran for 2 h, which encompasses the city rush hour. The 2-h duration was chosen since it allowed at least two complete circuits of the route. The vehicle then returned to the depot for half an hour, to allow a change of driver and exchange of PEMS batteries, before setting out for the second two hour test at 9 a.m. Vehicle 1 was tested in February, with a mean ambient temperature over the tests of 8.7°C, whereas vehicle 2 was tested in May, with a mean ambient temperature of 16.1°C. The weather conditions were otherwise similar, with little or no rain and negligible wind.

5 Results and analysis

Table 2 shows the NO_x emissions from each vehicle for each test as well as the mean exhaust temperature, and Fig. 5 displays the cumulative NO_x output over each test. Since the ambient temperature was lower for vehicle 1 tests, the average exhaust temperature is lower. Furthermore, it should be noted that the second test on each day (1.2, 1.4, 2.2 and 2.4) has higher average temperatures than the first test on each day (1.1, 1.3, 2.1 and 2.3) since some heat is retained in the engine and exhaust system during the pause in testing. This results in these tests producing less NO_x. It should be noted that even in the most favourable conditions (second test of the day in warmer weather – i.e. tests 2.2 and 2.4), the vehicles emit NO_x in excess of three times the Euro V heavy-duty limit determined in steady state and transient testing (at 2.0 g/kWh).

A GPS trace of the route during a particular run is shown in Fig. 6. The trace is coloured by the NO_x emissions per kilometre over the route, with the lowest in green, denoting 0 g/km, and the highest in red, denoting 1.7 g/km. It is clear that the city centre is prone to significant NO_x emissions, due to low vehicle speed thanks to congestion and junctions, and frequent bus stops. This causes the SCR to cool significantly, leading to higher NO_x emissions. By contrast, the residential areas see less NO_x emissions. Stops are fewer in this portion of the route, which helps to keep the catalyst at operating temperature, as demonstrated in Fig. 7.

5.1 Low-speed operation

Short vehicle stops, such as those made at bus stops, traffic lights or junctions, are typically of a duration between 10 and 60 s. During testing, these occur most frequently in the city centre, denoted (B) in Fig. 6. Such stops cause a drop in catalyst temperature of typically around 40°C. The temperature of the catalyst falls significantly during the stationary period. Whilst the vehicle is stationary with the engine idling, the exhaust gas has a low flow rate and decreasing temperature, this is shown in the first part of Fig. 8 in the period up to 2420 s. As such, when the vehicle moves off after this, this cooler gas is forced through the catalyst, resulting in yet further cooling. Even with 3 min of sustained engine load, the temperature does not recover to nominal operating conditions. The result of this is a significant impact on NO_x reduction, becoming significantly worse than average, as seen in Fig. 8. The aftertreatment system achieves only 14% NO_x reduction during the period shown.

5.2 Nominal temperature operation

Conversely, sections of the route which involve high engine load maintain the catalyst in its operating temperature region. This is particularly the case outside the city centre. This is due to increased changes in elevation, less frequent stopping for bus stops, and improved traffic flow allowing the vehicle to keep moving. Particularly when climbing hills, it is common for engine power to reach its maximum for repeated periods of several seconds. This high load leads to catalyst outlet temperatures in excess of 280°C,

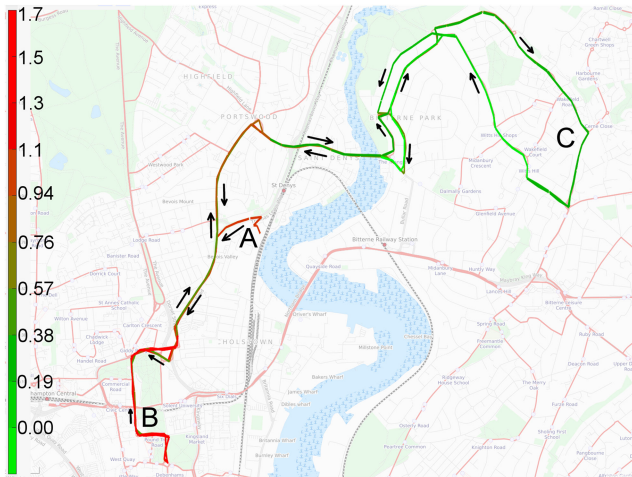

Fig. 6 Vehicle position trace recorded by the telematics unit on Test 2, Vehicle 2. The trace colour denotes NO_x from 0 g/km (green) to 1.7 g/km (red). Labelled are the bus depot (A), the main pedestrian thoroughfare in the city centre (B) and the hilly residential area (C). Driving direction is indicated by the arrows. Map data © OpenStreetMap contributors [11]

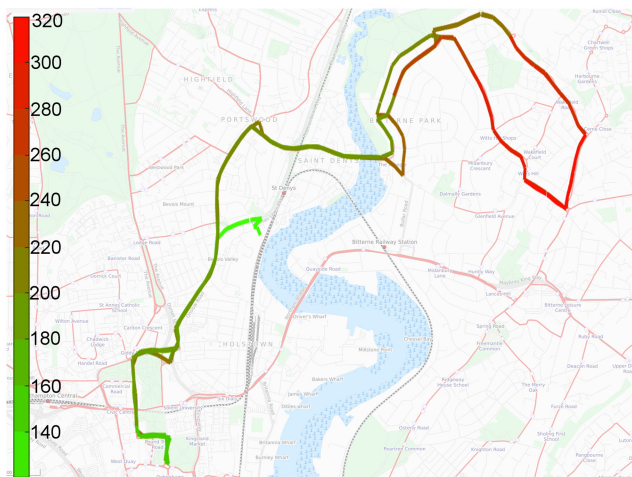

Fig. 7 Vehicle position trace recorded by the telematics unit on Test 2, Vehicle 2. The trace colour denotes catalyst gas outlet temperature from 140°C (green) to 320°C (red). Map data © OpenStreetMap contributors [11]

which is in the range required for optimal conversion of NO_x . Consequently, the SCR achieves a relatively high 66% NO_x reduction in the same period, as shown in Fig. 9. Notice that there are some periods where the efficiency reaches very close to 100%, which occurs when the correct amount of ammonia is present on the catalyst surface to react with the NO_x present. The control system can achieve this more easily during periods of quasi-steady-state operation, as seen around 3600 and 3900 s in Fig. 9.

Further evidence of this is seen in the scatter plot shown in Fig. 10, which plots the mean SCR outlet temperature versus the mass of NO_x emitted in each kilometre of the route for one particular test. The inverse correlation of NO_x emitted with gas temperature is clear. We see that a catalyst temperature of 250°C or higher is required in order for the SCR to achieve optimal conversion of NO_x .

The concentration of NO_x upstream of the SCR was required in order to estimate the NO_x reduction. In order to achieve this, during a particular test, a period of just over 10 min occurred during which an SCR fault was present and the catalyst was non-operational. As such, the tailpipe NO_x data recorded during this period is equivalent to the catalyst inlet NO_x . A neural network with 20 input delay taps and 20 feedback delay taps, and three hidden layers was trained using this data and four parameters recorded

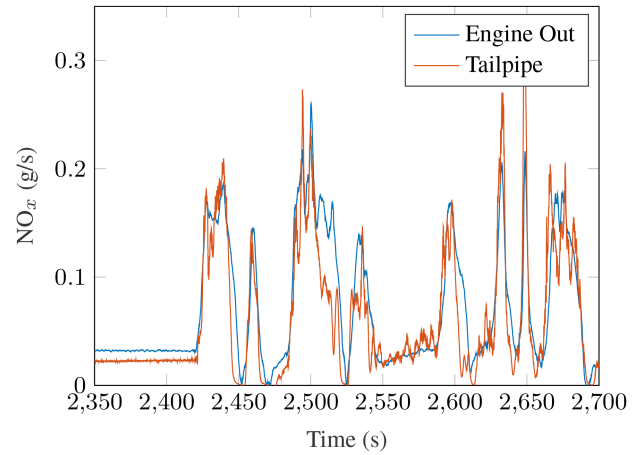

Fig. 8 Catalyst cooling reduces NO_x conversion to 14% in urban sections of the route

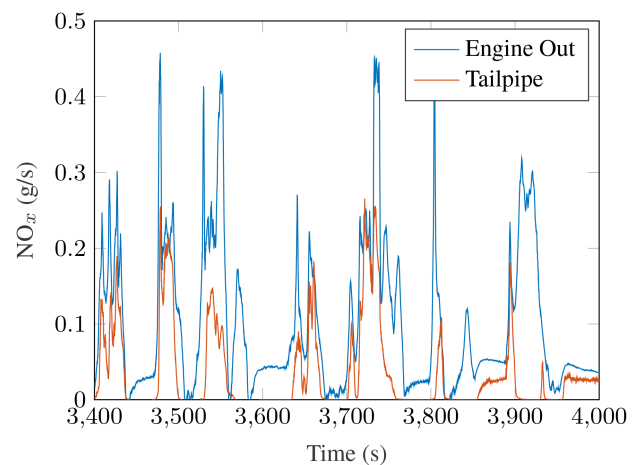

Fig. 9 Engine output NO_x and tailpipe NO_x during a period of nominal temperature operation

from the CAN bus: engine fuelling rate, engine speed, engine intake mass air flow and SCR catalyst inlet gas temperature. The results showed a close match with an R -value of 0.864 between the trained model and the measured tailpipe emissions.

6 Need for thermal management

The experimental results collected prove that the SCR catalyst operating temperature is key to achieving the NO_x reduction that is required to meet emissions targets in off-cycle operation. There have been several efforts to characterise the low-temperature kinetic effects [12]. Furthermore, there have been attempts to develop a catalyst that is particularly suited to operation at low temperatures [13]. Catalyst models that focus specifically on the kinetics which dominate at low temperatures have also been a part of the research in this field [14]. Another way to improve the catalyst efficiency is through advanced control of the ammonia injection. The use of reference governor approach [15] and some of the authors' recent works on model predictive control [16, 17] have shown promise for achieving improved NO_x reduction in this temperature limited operating region, since it allows operation closer to constraint boundaries than classical control. However, it is clear from this work that this is not sufficient to meet emissions targets: additional thermal management of the catalyst is required.

Optimisation of an existing engine setup for the purposes of aftertreatment thermal management is examined in [18]. In this work, three parameters are considered: start of injection timing, variable geometry turbine control, and actuation of an intake throttle. This is extended in [19], wherein the additional fuel consumption implied by this approach is somewhat mitigated by waste heat recovery. Provision of an electric catalyst heater was investigated in [20]. The unit had a rated power of 3 kW but was

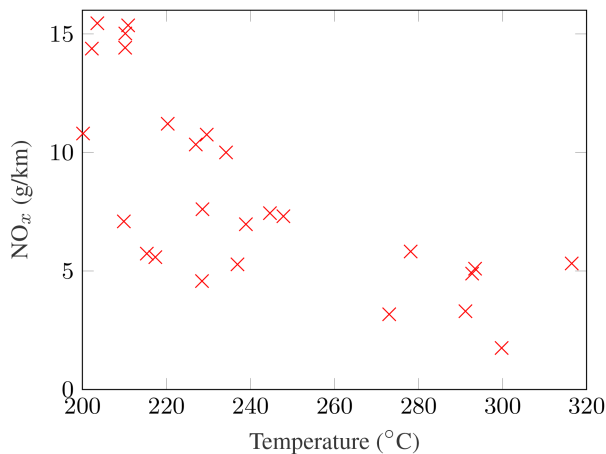

Fig. 10 Mean SCR outlet gas temperature versus mass of NO_x emitted per kilometre on Test 2, Vehicle 2

tested on a testbed without any control – the heater was either enabled or disabled. The results conclude that in low space velocity operation in the 180°C and above region, the NO_x reduction can be improved by as much as 15.9%. Finally, an interesting approach was considered in [21], wherein actuated ‘blinds’ were fitted around the catalyst housing, which can be controlled to open and close depending whether catalyst cooling is to be encouraged or discouraged. This work is particularly relevant as the target vehicles were buses, albeit fitted with hybrid electrical systems in this instance. The electrical heater and the ‘blinds’ could be retrofitted without significant modification to the engine control systems.

7 Conclusions

Despite a focus on urban NO_x concentrations and a resulting uptake in aftertreatment technology such as SCR in recent years, city centre environments continue to experience concentrations above safe exposure levels. In terms of abatement technology, SCR has proven extremely effective, and thus popular, for the control of NO_x from heavy duty vehicles. In this work, we tested two Euro V buses, factory fitted with SCR, using a combination of PEMS equipment and a custom telematics unit, which allowed us to gain a complete picture of the operating conditions of the aftertreatment systems. We found that the NO_x emissions were well above their design levels, and we showed that the temperature of the catalytic surface has a profound effect on the ability of the catalyst to function as intended. Whilst the catalyst remains in the operating condition where reaction rates are temperature limited, NO_x conversion is necessarily suboptimal. Urban environments are currently of key concern for NO_x levels, yet it is precisely these circumstances which require frequent stopping and starting of vehicles, which we have demonstrated has a deleterious effect on catalyst temperature and therefore emissions. This is particularly true of public transport vehicles like buses, which are obliged to stop regularly even without congestion and junctions, meaning they are incapable of meeting the emissions limits for which they were intended.

We reviewed several possible thermal management technologies in the literature to address this problem. Several of these have proven effective, and if implemented, could significantly improve the efficiency of the NO_x abatement system. Such a technology provides the means to control the fundamental tradeoff between fuel consumption and NO_x emissions, allowing the control system to meet both targets simultaneously. Furthermore, some of these could be retrofitted to the factory SCR, or retrofitted alongside SCR, in order to bring older vehicles up to date with current emissions standards. Whilst brand new vehicles are significantly less polluting than their older counterparts, the turnover rate of heavy good vehicle fleets, including buses, implies significant time for the entire fleet to reach Euro VI. Retrofitting of SCR and thermal management technologies will accelerate this.

Future work would preferably involve verification of the deficiency in SCR efficiency by testing the vehicles in a testbed environment using test cycles. It would also be worthwhile to compare the results to a Euro VI bus to verify the claims that more modern vehicles improve significantly on the results discussed in this work. Regarding solutions to the problem of NO_x from older vehicles, future work will include development of a model of the SCR chemical and thermal dynamics on the buses tested in this work. Using this model, it is planned that retrofit thermal management technologies can be tested in simulation to estimate the improvement in performance of the emissions system, and the resulting fuel penalty. Another direction is to widen the scope of the study to include design-time parameters which impact the efficiency of the SCR system, such as catalyst size, substrate and positioning, and also implementing advanced control method for the urea injection.

8 Acknowledgments

The authors thank the Department for Transport and Southampton City Council for their help in project commissioning and coordination, as well as First Group UK for the supply of vehicles, technicians and drivers. The authors thank Ricardo UK Ltd. for their sponsorship of the EngD project and advice regarding off-cycle PEMS and real driving emissions (RDE) testing of vehicles. The provision of EngD funding from EPSRC (grant no. EP/G036896/1), the Industry Doctoral Training Centre in Transport and the Environment, and Royal Society (grant no. RG140095) are gratefully acknowledged. Map data copyrighted OpenStreetMap contributors and available from <http://www.openstreetmap.org>.

9 References

- [1] Committee on the medical effects of air pollutants.: ‘Statement on the evidence for the effects of nitrogen dioxide on health’, 2014
- [2] Carslaw, D.C.: ‘Evidence of an increasing NO₂/NO_x emissions ratio from road traffic emissions’, *Atmos. Environ.*, 2005, **39**, (26), pp. 4793–4802
- [3] Low Carbon Vehicle Partnership.: ‘The Journey of the Green Bus’, 2015
- [4] Laybourn Langton, L., Quilter Pinner, H.: ‘Solving London’s air pollution Crisis’ (Institute for Public Policy Research, London, 2016)
- [5] The UK Department for Transport.: ‘Vehicle Emissions Testing Programme – Moving Britain Ahead’, 2016. April
- [6] Carslaw, D.C., Rhys Tyler, G.: ‘New insights from comprehensive on-road measurements of NO_x, NO₂ and NH₃ from vehicle emission remote sensing in London, UK’, *Atmos. Environ.*, 2013, **81**, (2), pp. 339–347
- [7] Transport for London.: ‘Emissions from the TFL bus fleet’, 2015. July
- [8] Transport for London.: ‘London bus fleet audit’, 2016. March
- [9] Department for Environment Food & Rural Affairs.: ‘Improving air quality in the UK Tackling nitrogen dioxide in our towns and cities’, 2015. December
- [10] First Group.: ‘First Group Number 7 Route - Southampton’, 2017. Available at https://www.firstgroup.com/uploads/maps/Route_7_0.pdf
- [11] OpenStreetMap Contributors.: ‘Planet dump retrieved from <http://planet.osm.org>’, 2017. Available at <http://www.openstreetmap.org>
- [12] Koebel, M., Elsener, M., Madia, G.: ‘Reaction pathways in the selective catalytic reduction process with NO and NO₂ at low temperatures’, *Ind. Eng. Chem. Res.*, 2001, **40**, pp. 52–59
- [13] Ettireddy, P.R., Kotrba, A.: ‘Low temperature SCR catalysts optimized for cold-start and low-load engine exhaust conditions’, SAE Technical Paper 2015-01-1026, 2015
- [14] Tronconi, E., Nova, I., Ciardelli, C., *et al.*: ‘Modelling of an SCR catalytic converter for diesel exhaust after treatment: dynamic effects at low temperature’, *Catal. Today*, 2005, **105**, (3–4), pp. 529–536
- [15] Kolmanovsky, I., Garone, E., Di Cairano, S.: ‘Reference and command governors: A tutorial on their theory and automotive applications’. American Control Conf. (ACC), 2014, vol. 2014, pp. 226–241
- [16] Sowman, J., Laila, D.S., Cruden, A.J., *et al.*: ‘A predictive control approach to diesel selective catalytic reduction’. Proc. European Control Conf., Linz, 2015
- [17] Sowman, J., Laila, D.S., Cruden, A.J., *et al.*: ‘Nonlinear model predictive control for cold start selective catalytic reduction’. Proc. 5th IFAC Conf. Nonlinear Model Predictive Control, 2015
- [18] Cavina, N., Mancini, G., Corti, E., *et al.*: ‘Thermal management strategies for SCR after treatment systems’, SAE Technical Paper 2013-24-0153, 2013
- [19] Pradhan, S., Thiruvengadam, A., Thiruvengadam, P., *et al.*: ‘Investigating the potential of waste heat recovery as a pathway for heavy-duty exhaust aftertreatment thermal management’, SAE Technical Paper 2015-01-1606, 2015
- [20] Feng, X., Ge, Y., Tan, J., *et al.*: ‘Effects of electrically heated catalyst on the low temperature performance of vanadium-based SCR catalyst on diesel engine’, SAE Technical Paper 2014-01-1527, 2014
- [21] Wang, L., Zhu, C., Fan, L., *et al.*: ‘Study on thermal management system for SCR on hybrid electric buses’. Asia-Pacific Power and Energy Engineering Conf., APPEEC, 2011