

Improving gasoline direct injection (GDI) engine efficiency and emissions with hydrogen from exhaust gas fuel reforming

Fennell, D. , Herreros, J. M. and Tsolakis, A.

Author post-print (accepted) deposited in CURVE January 2016

Original citation & hyperlink:

Fennell, D. , Herreros, J. M. and Tsolakis, A. (2014) Improving gasoline direct injection (GDI) engine efficiency and emissions with hydrogen from exhaust gas fuel reforming.

International Journal of Hydrogen Energy, volume 39 (10): 5153–5162

<http://dx.doi.org/10.1016/j.ijhydene.2014.01.065>

ISSN 0360-3199

DOI 10.1016/j.ijhydene.2014.01.065

Copyright © and Moral Rights are retained by the author(s) and/ or other copyright owners. A copy can be downloaded for personal non-commercial research or study, without prior permission or charge. This item cannot be reproduced or quoted extensively from without first obtaining permission in writing from the copyright holder(s). The content must not be changed in any way or sold commercially in any format or medium without the formal permission of the copyright holders.

This document is the author's post-print version, incorporating any revisions agreed during the peer-review process. Some differences between the published version and this version may remain and you are advised to consult the published version if you wish to cite from it.

Improving Gasoline Engine Efficiency and Emissions with Hydrogen from Exhaust Gas Fuel Reforming

Daniel Fennell, Jose Herreros, Athanasios Tsolakis*

School of Mechanical Engineering, University of Birmingham, Edgbaston, Birmingham, B15 2TT, UK

* Corresponding author: a.tsolakis@bham.ac.uk

Tel: +44 121 414 4170

Fax: +44 121 414 7484

Graphical Abstract

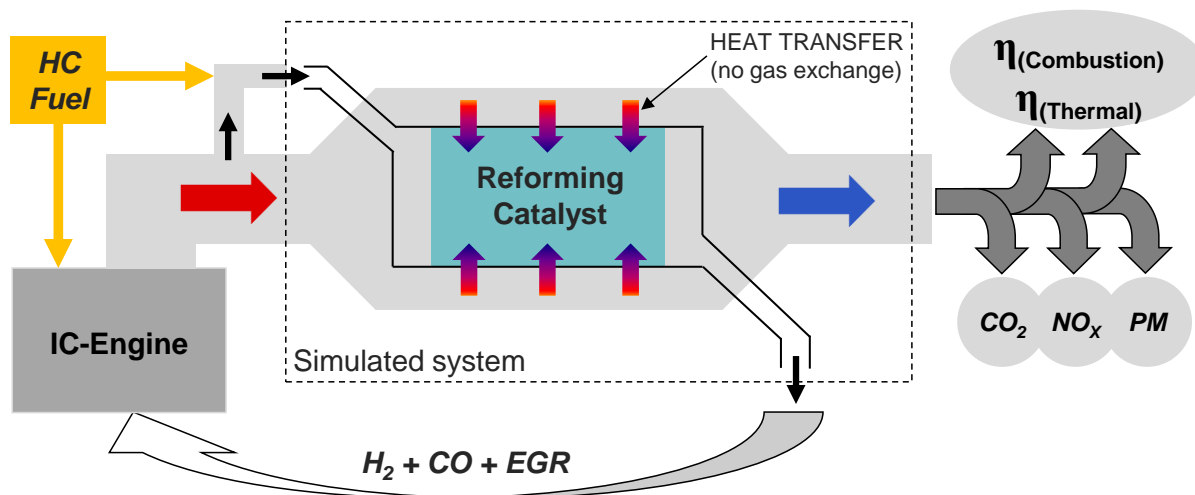

Abstract

Exhaust gas fuel reforming has been identified as a thermochemical energy recovery technology with potential to improve gasoline engine efficiency, and thereby reduce CO₂ in addition to other gaseous and particulate matter (PM) emissions. The principle relies on achieving energy recovery from the hot exhaust stream by endothermic catalytic reforming of gasoline and a fraction of the engine exhaust gas. The hydrogen-rich reformate has higher enthalpy than the gasoline fed to the reformer and is recirculated to the intake manifold, i.e. reformed exhaust gas recirculation (REGR).

The REGR system was simulated by supplying hydrogen and carbon monoxide (CO) into a conventional EGR system. The hydrogen and CO concentrations in the REGR stream were selected to be achievable in practice at typical gasoline exhaust temperatures. Emphasis was placed on comparing REGR to the baseline gasoline engine, and also to conventional EGR. The results demonstrate the potential of REGR to simultaneously increase thermal efficiency, reduce gaseous emissions and decrease PM formation.

Keywords

Exhaust-gas reforming; hydrogen; Exhaust Gas Recirculation (EGR); emissions; Particulate Matter (PM); Gasoline Direct Injection (GDI)

Abbreviations

TDC Top Dead Centre
CO Carbon Monoxide
COV Coefficient of Variation
EGR Exhaust Gas Recirculation

EGT Exhaust Gas Temperature
EVC Exhaust Valve Closing
GDI Gasoline Direct Injection
GNMD Geometric (particle) Number Mean Diameter
HC Hydrocarbon
IMEP Indicated Mean Effective Pressure
IVO Intake Valve Opening
MFB Mass Fraction Burned
NO_x Oxides of Nitrogen
PFI Port Fuel Injection
PM Particulate Matter
PMEP Pumping Mean Effective Pressure
REGR Reformed Exhaust Gas Recirculation
SMPS Scanning Mobility Particle Sizer
TWC Three Way Catalyst

1. Introduction

Increasingly stringent legislation relating to vehicle emissions and fuel economy in recent years has led to the automotive industry introducing a wide variety of new technology into production vehicles. Exhaust gas fuel reforming is one technique proposed for exhaust energy recovery [1, 2]. The thermodynamic benefit of exhaust gas fuel reforming depends on the dominance of two endothermic chemical reactions, known as steam reforming ((1) and dry reforming ((2). These reactions convert hydrocarbon (HC) fuel, in this application gasoline, into hydrogen and carbon monoxide, extracting energy from the exhaust stream in the process; the aim is to produce gaseous reformat fuel with higher enthalpy than the HC fuel supplied to the reformer. Reactants required in order to initiate the two reforming reactions are water and carbon dioxide, both of which are supplied by the engine exhaust gas. Any oxygen contained in the exhaust gas, typically less than 1% for a gasoline engine, will be consumed by full or partial oxidation ((3). These are exothermic reactions which may reduce the process efficiency; they can, however, be useful by raising the local catalyst temperature to increase reformer yields. The water-gas shift reaction ((4) occurs more readily later in the reforming process when the CO concentration has increased, and is beneficial to hydrogen yield but mildly exothermic.

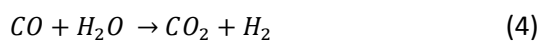
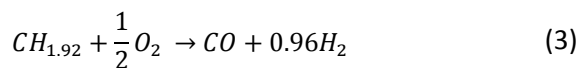
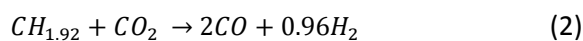
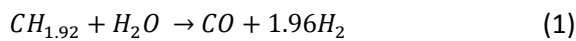

Fuel reforming technology also provides the possibility of further engine efficiency improvements due to the attractive combustion properties of hydrogen, as well as simultaneous benefits provided by charge dilution. Previous research into the effects of hydrogen enhanced (undiluted) gasoline combustion has indicated faster combustion rates [3] and increased combustion efficiency, while higher peak cylinder temperature and pressure increases the formation of oxides of nitrogen (NO_x)[4]. When coupled with charge dilution, hydrogen enhancement has been shown to stabilise combustion and extend the dilution limit for excess air [5] and EGR [6], in one case with concentrations of less than 1% by volume in the combustion charge [7]. There may be additional benefits to indicated efficiency and NO_x emissions, dependent upon the exact charge composition and engine operating condition.

The composition of reformat is heavily dependent upon the reaction temperature, as well as: catalyst formulation; reactor design; the HC fuel and feed gas compositions; and catalyst ageing (e.g. thermal deactivation/ sintering, coking and sulphur poisoning). All of these factors must be considered in future reformer development. There have been various studies [8-10] that have used idealised, high quality reformat compositions in combustion studies which are not practical for fuel reforming at typical gasoline engine exhaust temperature. Reforming studies have shown that currently achievable hydrogen and CO yields are in the range of 5-10% [11, 12].

EGR can be beneficial to engine operation with improved fuel economy and reduced NO_x emissions across the engine range. At low load this is mainly due to reduced pumping work and lower heat losses, and at high load significant fuel savings can be attributed to a number of factors: higher heat capacity of the charge results in lower knock tendency and improved combustion phasing [13, 14] (advancing ignition towards the optimum timing); lower exhaust gas temperature can eliminate the requirement

for fuel enrichment at high engine speed/load [15]; and lower combustion temperatures reduce heat losses. There is also a higher value of the ratio of specific heats of the combustion charge with EGR which increases the ideal thermodynamic efficiency. This value is higher both for the raw charge mixture, and during combustion due to lower combustion temperature. Further to this, the elimination or reduction of knock tendency [16] may permit increased compression ratio, improving efficiency at all operating conditions.

The maximum dilution rates used in gasoline engines are limited by the deterioration of combustion stability. Hydrogen can enable higher dilution rates to be used in gasoline engines and so reformed exhaust gas recirculation (REGR) offers the potential to equal or excel the engine efficiency benefits of EGR, in addition to achieving heat recovery from the exhaust stream.

In addition to these benefits, EGR has been shown to reduce particulate matter (PM) emissions from port fuel injected [17-19] and direct injected [20] gasoline engines, and so EGR may assist in achieving particle number emission targets due to be introduced to Euro 6c regulations in 2017, and CARB LEV III. PM mass reductions of 65% were demonstrated with a gasoline direct injection (GDI) engine using cooled, external EGR [20], with a similar trend for internal EGR. Elsewhere though, EGR has been reported to increase particle number emissions from a port fuel-injected (PFI) engine [21]. Hydrogen enhancement has been shown to reduce PM formation in GDI engines [3, 22] and so it may be expected that REGR will result in further reductions over conventional EGR.

On-board generation of hydrogen-rich gas has been investigated using various types of prototype fuel reformer in the past [9, 23-26], in some cases with particular focus on cold-start performance [27, 28]. Elsewhere, in-cylinder reforming has been employed in a system known as dedicated EGR [29] which uses rich combustion in one cylinder of a multi-cylinder engine to generate hydrogen rich EGR, similarly to REGR.

The aim of this paper is to establish the fuel efficiency and emissions performance of a multi-cylinder GDI engine operating with REGR from an exhaust gas fuel reformer. To achieve this, bottled hydrogen/CO was added to conventional EGR to generate a reformat-like mixture containing representative concentrations of the diluent gas species, namely CO₂, nitrogen and water vapour. This allowed the engine efficiency, combustion performance and gaseous and PM emissions with REGR to be compared to the baseline gasoline engine, and also to performance with conventional EGR.

2. Experimental setup and test conditions

Engine: The engine used for this study was a 2 litre, four-cylinder GDI engine with dual scroll turbocharger, side-mounted solenoid injectors and a centrally located spark plug. Aftertreatment consists of a conventional three-way catalyst (TWC) and so the engine uses a homogeneous, stoichiometric combustion strategy. A camshaft driven high pressure pump feeds the fuel rail and varies the fuel pressure with engine operating condition. In production specification the engine does not use external EGR, instead utilising dual variable cam timing to induce internal EGR when required. For this study a high pressure EGR loop was installed to allow for a direct comparison of REGR to conventional EGR. An EGR heat exchanger fed with engine coolant passively cooled the re-circulated gas before being introduced into the intake manifold. An air to water heat exchanger cooled the intake air to control charge temperature measured at the inlet port. A variable area flow meter measured the flow of pre-mixed hydrogen and carbon dioxide into the EGR stream to generate a gas composition representative of reformat. This was introduced after the EGR valve but well upstream of the intake manifold. A

schematic of the engine configuration is detailed in Figure 1. Further details of the engine specification are listed in Table 1.

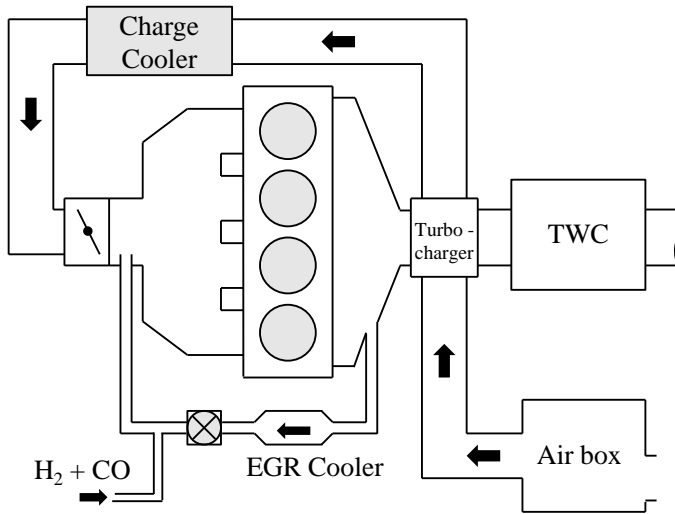

Figure 1 - Test Schematic

Table 1 - Engine specification

Compression Ratio	10:1
Bore x stroke	87.5 x 83.1mm
Turbocharger	Borg Warner k03
Rated power	149 kW at 6000 rpm
Rated Torque	300 Nm at 1750-4500 rpm
Engine management	Bosch ME17

Cylinder pressure measurements were taken from cylinder four using an AVL piezo-electric pressure transducer and charge amplifier, referenced to the engine cycle using a Baumer 720 pulse per revolution magnetic encoder. An absolute pressure transducer located in the intake runner close to the port entry was used to reference the cylinder pressure trace to the intake manifold pressure at BDC after the intake stroke.

Emissions analysis: Engine out gaseous emissions were measured using a Horiba MEXA-7100DEGR, which also measured the intake manifold CO₂ concentration in order to calculate the charge dilution rate according to (5). PM was sampled using a TSI scanning mobility particle sizer (SMPS) consisting of a series 3080 electrostatic classifier, a 3081 Differential Mobility Analyser and a 3775 Condensation Particle Counter. The sample and sheath flow rates were set such that the measurement (particle diameter) range was nominally 10-407nm. A TSI rotating disk thermodiluter provided 30:1 dilution at 150°C. The SMPS sampled exhaust stream after the TWC due to its influence on removing HC species which act as precursors to volatile particle formation [30], and can become a significant source of variation in measurements.

$$\text{Charge Dilution Rate, \%} = \frac{(CO_2)_{\text{manifold}}}{(CO_2)_{\text{exhaust}}} \times 100 \quad (5)$$

Engine conditions: The engine conditions selected for investigation were: 35 Nm/3 bar indicated mean effective pressure (IMEP) at 2100 rpm, which represents a key steady state condition in the urban section of the new European drive cycle for a typical mid-size/large family vehicle with this 2 litre engine; and 105 Nm/7.2 bar IMEP at 2100 rpm which is typical of the highest load transient in the extra-urban drive cycle. The baseline condition was compared to each EGR and REGR condition with the

ignition timing optimised with the minimum advance for maximum torque. Injection timing, fuel pressure and other engine parameters were held at the standard calibration values, with the exception of cam phasing which was varied in one part of the study in order to investigate the effects of reducing internal EGR at low engine load. Engine performance was assessed at increasing EGR and REGR rates until the deterioration of combustion stability limit was reached, defined by the coefficient of variation (COV) of IMEP exceeding 5%.

Reformate composition: A fixed 3:1 hydrogen/CO ratio would be used throughout the study, based on typical Platinum-Rhodium reformer catalyst performance in the region of 500°C which was anticipated to be the least favourable, but functional temperature for reforming with a GDI engines at low engine load. The flow rate of the hydrogen/CO gas mixture was adjusted at each test point so that the total volumetric combustible gas fraction in the REGR was 0.05 or 0.1. Therefore, the hydrogen concentration in the REGR stream at each condition would be 3.75% or 7.5% respectively, with 1.25% or 2.5% CO. For the 7.2 bar IMEP test condition, higher combustible gas fractions of 0.1 and 0.15 were used. This was based on the knowledge that higher exhaust and reformer temperature leads to increased hydrogen and CO yields [11]. The hydrogen concentration in the combustion charge at each test point is shown in Table 2, which also specifies the energy fraction of the total fuel supplied as reformate (hydrogen and CO) for each test.

Table 2 - Hydrogen Concentration in REGR stream and intake at the low load test condition

	REGR Combustible	Percentage REGR			
	Gas Fraction	7%	14%	21%	28%
REGR stream	0.05		3.8%		
hydrogen, %	0.1		7.5%		
Intake hydrogen	0.05	0.2%	0.5%	0.7%	1.0%
concentration, %	0.1	0.5%	1.0%	1.5%	2.0%
Reformate energy	0.05	1.6%	3.7%	6.1%	8.8%
fraction, %	0.1	3.2%	7.3%	12.5%	17.7%

3. Experimental results

3.1 Low-load engine performance and gaseous emissions with REGR

Initially the engine retained the standard calibration cam timings, which employ a late, high overlap configuration that results in a high residual gas fraction for reduced pumping work and NO_x formation at low engine load.

At standard calibration cam timing indicated efficiency (Figure 2a) was increased initially with EGR due to reduced pumping work and lower heat losses. As the EGR rate was increased further the efficiency dropped off due to a reduction in combustion stability to the point of misfire (Figure 2b). Combustion durations increased monotonically with dilution rate, more significantly for the initiation phase than the main combustion phase; these are represented by the 0-10% mass fraction burned (MFB) and 10-90% MFB durations in Figure 2c and d. This deterioration in combustion speed was associated with the increasing inert gas fraction.

Significantly increased unburned HCs at the higher EGR rates were caused by the deterioration of combustion stability and the resulting misfire (Figure 2e). Lower in-cylinder temperature with EGR also reduces the rate of post-combustion HC oxidation. As expected, NO_x emissions dropped with increasing EGR (Figure 2f). This is again due to reduced combustion temperature which decreases the rate of NO_x

formation. The thermal dilution effect of the inert gases in the charge with EGR (i.e. greater total heat capacity), and the reduction of the heat release rate, lower the in-cylinder temperature. This counters any incremental increase in temperature due to higher cylinder pressure (associated with greater charge mass) or advanced ignition timing. EGR dilution also leads to a slightly lower oxygen concentration in the charge and the exhaust stream; if the oxygen concentration is also lower while the temperature is sufficiently high for NO_x formation, then it follows that the rate of NO_x formation would be reduced.

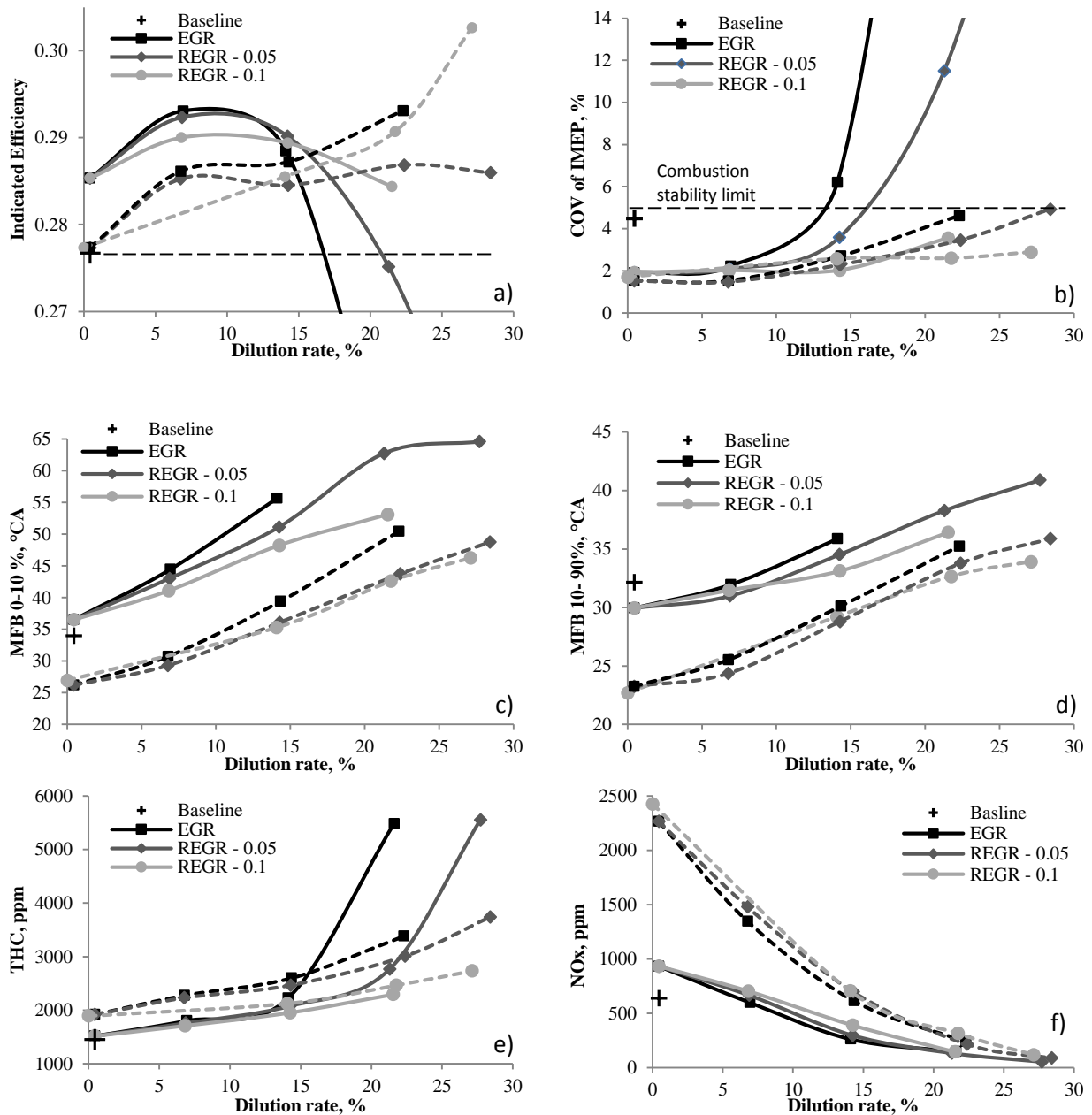

Figure 2 - Effect of EGR and REGR dilution rate on various engine performance parameters: a) indicated efficiency, b) combustion stability, c) combustion initiation, d) combustion duration, e) THC emissions and f) NO_x emissions. *Standard calibration cam timing (solid lines), cam timings for low internal EGR (dashed lines)*

The indicated efficiency for REGR was slightly lower relative to EGR for the same dilution rate, until the combustion stability with EGR deteriorated. For REGR the COV of IMEP remained below 5%, indicating

that the hydrogen/CO in the REGR had a stabilising effect on combustion. These figures also show that an incremental increase in combustion rate was achieved with REGR relative to EGR, for a given dilution rate. This was attributed to the beneficial combustion properties of hydrogen, in particular the higher laminar flame speed [9], which explains the large reduction in the flame initiation period (MFB 0-10%) when combustion is primarily laminar.

The mechanisms for reducing NO_x formation with EGR are also applicable to REGR due to the very similar charge composition, and the net result is again significantly reduced NO_x emissions with respect to the baseline condition. However, the higher adiabatic flame temperature of hydrogen and CO compared to gasoline results in higher in-cylinder temperature, leading to slightly increased NO_x formation rate for REGR relative to EGR. For the same reason HC oxidation is increased and HC emissions are lower.

From the results obtained with the standard cam timings it was clear that the level of internal EGR should be reduced in order to increase the achievable REGR rate, and increase the concentration of hydrogen and CO in the charge.

In order to reduce the internal EGR rate and enable greater external dilution, various cam timings were tested with reduced overlap and positioned closer to top dead centre (TDC). The relative amount of internal EGR at each setting was gauged by observing the change in combustion rate and NO_x emissions, as well as considering the effect on indicated efficiency and intake manifold pressure. The valve timings for the low internal EGR condition were selected as inlet valve opening (IVO) at -10° and exhaust valve closing (EVC) at 8° after TDC.

Altering the cam timings to the low internal EGR setting when there was no external charge dilution reduced the indicated efficiency (Figure 2a), primarily due to lower intake manifold pressure which increased the pumping work. The introduction of external dilution improved indicated efficiency monotonically up to the dilution limit which was extended to 21% for EGR and 28% with REGR. The peak efficiency achieved with the EGR dilution method was very similar for both cam timings, albeit while using very different external EGR rates. This implies that the total dilution rates (internal + external EGR) are similar in both cases, supported by comparable emissions and combustion results (Figure 2b-f).

It is apparent that the presence of hydrogen and CO in REGR does not lead directly to improved indicated efficiency relative to EGR, however the possibility to operate the engine with higher overall dilution rate does. This is also combined with significantly reduced NO_x emissions and moderately increased HCs.

In these tests the engine used the standard ignition system and spark plug, and single-pulse direct fuel injection for a homogenous charge mixture. High energy ignition systems are able to increase the dilution tolerance with EGR [31] and this could be expected to translate to increasing REGR tolerance. Utilising dual injection to generate a partially stratified charge has been shown to benefit combustion stability and fuel economy with an EGR diluted charge [32]. The application of these methods to the REGR case could yield further efficiency improvements.

3.2 Mid-load engine performance and gaseous emissions with REGR

The following section presents results for the engine operating at a higher, mid-load condition of 105Nm/7.2 bar IMEP at 2100 rpm. The target dilution rate was 21%, the maximum achievable with the high pressure EGR loop under these manifold conditions. The ignition timing was set for either optimum combustion phasing (defined by MFB50% = 8° ± 2°aTDC) or knock limited spark minus 2° crank angle.

Table 3 defines the conditions for the 7.2 bar IMEP tests and the results are summarised in Table 4. Combustion was stable for all test conditions at this engine load.

Table 3 - Test conditions at 7.2 bar IMEP, 2100rpm

Test point	Dilution rate, %	%H ₂ in REGR	%CO in REGR	%H ₂ Intake	%CO Intake	REGR Energy, %	Ignition, °bTDC	MAP (bar)
Baseline	0	0	0	0	0	0	21	0.85
EGR	21	0	0	0	0	0	44	1.00
REGR (0.1)	20	8.1	2.7	1.8	0.6	9	33	1.01
REGR (0.15)	20	11.9	4.0	2.8	0.9	15	31	1.02

Table 4 - Summary of results for 7.2 bar IMEP at optimum ignition timing [indicated engine efficiency (η_{ind}), percentage increase in efficiency ($\Delta\eta_{ind}$), brake specific emissions, combustion efficiency (η_{comb}), exhaust gas temperatures (EGT) and pumping work (PMEP)]

Test Point	η_{ind}	$\Delta\eta_{ind}$ (%)	BSHC g/kWh	BSNO _x g/kWh	BSCO g/kWh	η_{comb}	EGT (Pre-turbine)	EGT (Post-TWC)	PMEP (bar)
Baseline	0.340	0	2.4	16.0	28.6	0.960	743	727	-0.47
EGR	0.356	+4.7	3.9	2.6	20.6	0.962	655	645	-0.34
REGR 0.1	0.357	+4.8	3.3	2.7	17.5	0.967	661	642	-0.33
REGR 0.15	0.354	+4.0	3.0	3.0	16.4	0.970	658	635	-0.31

The effect of EGR on combustion was, as expected, to reduce the burn rate. As was the case at lower engine load this was most significant in the ignition phase of combustion, indicated in Figure 3 by longer MFB 0-10% duration. Figure 3 also shows that the trend was similar but less pronounced for the main combustion phase duration.

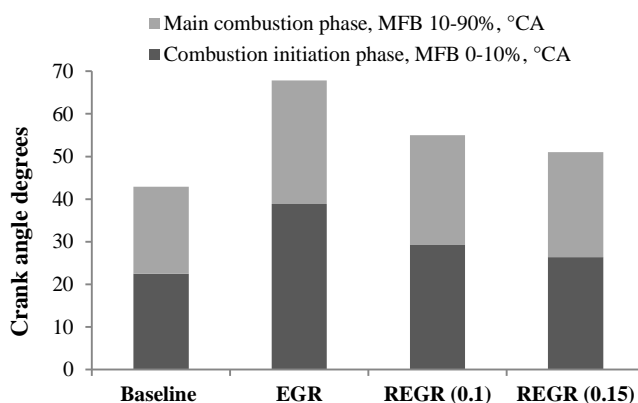

Figure 3 - Combustion phase durations

BSHC emissions were almost doubled by EGR due to lower cylinder temperatures and reduced oxidation rate, however combustion efficiency was maintained (Table 4). This can be attributed to the simultaneous reduction in CO emissions, which also reduces the estimated value for hydrogen

concentration in the exhaust stream ((6). Together these offset the change in combustion efficiency ((7) due to increased unburned HCs.

Similarly to the low engine load results, the presence of hydrogen and CO in the charge for REGR influenced combustion by increasing the burn rate towards that of the baseline case, and resulted in further improvements to combustion efficiency. Slightly higher combustion temperatures relative to EGR led to an incremental increase in NO_x formation and HC oxidation rates, with corresponding changes to specific emissions values. Despite this, REGR offers greater than 80% reduction in BSNO_x compared to the baseline.

The simultaneous reduction of CO and slightly increased NO_x with REGR may have implications for TWC operation with regards to the suitable ratio of reducing and oxidising species in the feed gas. The CO: NO_x ratio remains favourable (in fact being increased when compared to the baseline) to remove NO_x by the CO reduction mechanism. It may be the case that complete conversion of CO (and HCs) is not possible if NO_x becomes too low, in which case more oxygen should be made available in the exhaust stream. This may be achieved with engine control by shifting the stoichiometry fluctuations in the lean direction. This would also restore the overall reducing/oxidising balance by incrementally increasing NO_x formation and reducing CO and HCs.

$$\text{Estimated exhaust stream hydrogen concentration, } H_{2,ex} \text{ (ppm)} = 10000 * \left[\frac{(CO_{ex}, \% * H_2O_{ex}, \%)}{3.5 * CO_{2,ex}, \%} \right] \quad (6)$$

$$\text{Combustion efficiency, } \eta_{comb} = 1 - \left[\frac{(LHV_g \cdot \dot{m}_{HC,ex} + LHV_{H_2} \cdot \dot{m}_{H_2,ex} + LHV_{CO} \cdot \dot{m}_{CO,ex})}{(Total \text{ fuel supplied, MJ/s})} \right] \quad (7)$$

The improvement to indicated efficiency with EGR (Table 4) was attributed to the optimised combustion phasing and slightly lower pumping work due to the increased intake manifold pressure. In addition, lower combustion temperatures reduce the rate of heat loss from the combustion chamber. Indicated efficiency for REGR with both compositions was similar to that of EGR. It seems that the addition of hydrogen and CO provides no further efficiency benefit for the same recirculation rate. The incremental improvement in combustion efficiency with REGR was not sufficient to improve indicated efficiency compared to EGR.

Dilution with either EGR or REGR allowed for the combustion phasing to be advanced closer to the optimum, apparent by the advancement of the MFB50% timing from 12° aTDC (knock limited) for the baseline to 7° aTDC for each of the other conditions, visible in the MFB curves of Figure 4. This agrees with previous research that has shown EGR dilution [15, 32, 33] and hydrogen enhancement [8, 34] to be effective for attenuating knock.

Figure 4 also shows that higher peak cylinder pressures are generated with dilution, which is due to the increased charge mass relative to the baseline. Studying the rate of heat release curves it is seen that the baseline gasoline combustion process is appreciably retarded from the optimum (due to knock) meaning that the combustion process is releasing energy most quickly once the piston is too far into the expansion stroke. This ultimately reduces efficiency as it is a poor approximation of the idealised constant volume combustion process which is characteristic of the Otto cycle. Although the maximum rate of heat release is lower with diluted combustion, the position of the maximum is advanced much closer to TDC. It is also obvious that the hydrogen and CO in REGR results in a higher maximum rate of

heat release than for EGR, meaning that marginally less energy is released during the compression stroke and later in the expansion stroke, and so represents a closer approximation to constant volume combustion.

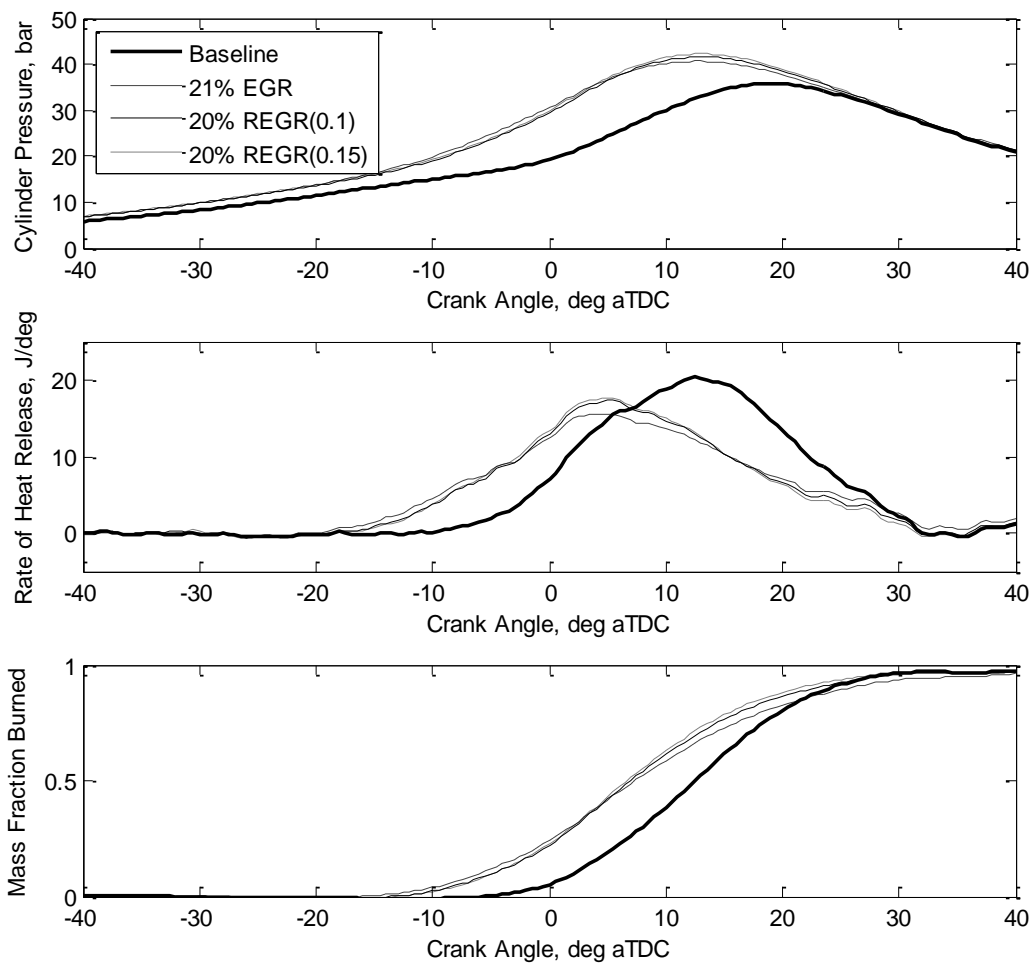

Figure 4 – In-cylinder pressure, Rate of heat release and Mass Fraction Burned curves for Baseline gasoline combustion, and diluted combustion with EGR and REGR

3.3 Particulate Matter (PM) emissions

At elevated engine load, PM formation in GDI engines becomes more significant. The formation of PM by nucleation of volatile species in the exhaust stream, and the adsorption of volatile species onto existing particles are processes that occur primarily during cooling and dilution of the exhaust gas [35]; for instance at the tailpipe exit, or in the PM sampling system. In these experiments, the PM sampling system was positioned after the TWC to minimise the influence of these two mechanisms on measurement variability, on the basis that the TWC has removed a large proportion of the volatile fraction from the exhaust stream. Heated dilution also aimed to limit nucleation mode particle formation.

Figure 5 illustrates the benefit that both EGR and REGR have on reducing total PM number and mass relative to the baseline gasoline condition. Further to that, REGR results in lower PM compared to EGR. This reduction in PM with EGR dilution is opposite to when cooled EGR is used in diesel engines. Because the average exhaust stream oxygen concentration is low and essentially fixed (0.5 - 0.8% for effective TWC operation), and the combustion temperatures with EGR are lower, it follows that the rate

of PM oxidation in the end gas is reduced which should then cause an incremental increase in PM emissions. This is clearly not the dominant effect, and so there must be other mechanisms leading to reduced PM emissions. Hedge et al conclude in their work that “EGR significantly inhibits the nucleation of the particles, to the extent that it overcomes the decrease in post-flame oxidation and the increased potential for agglomeration” [20]. There has been only a limited amount of research that demonstrates this effect of EGR on PM emissions in GDI engines, and as yet no fundamental research has established the exact mechanisms at work. That said, the reduced in-cylinder temperature with EGR will inhibit both soot formation and oxidation.

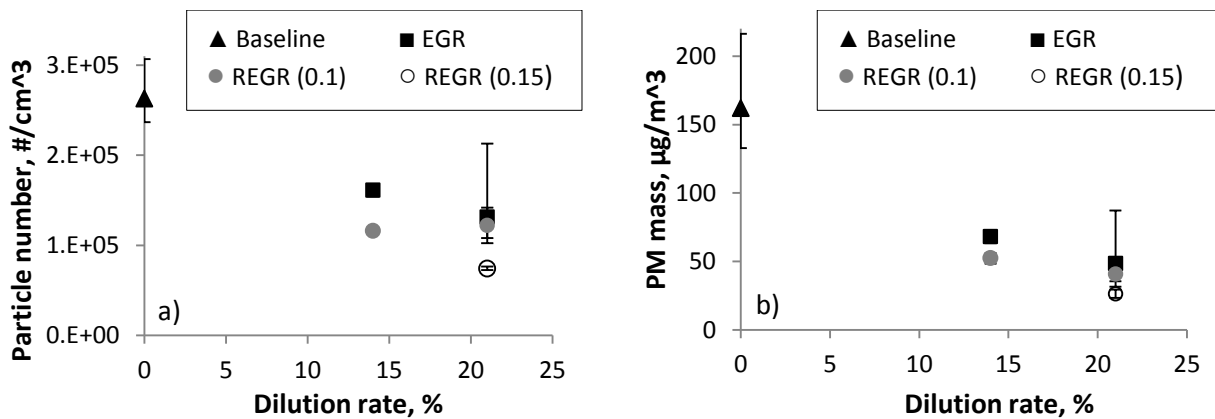

Figure 5 - Total PM number (a) and mass (b) concentration for a range of conditions at 7.2 bar IMEP/2100rpm

Another reason for lower PM formation can be attributed to the fact that EGR improves engine efficiency. Therefore, for a given engine load, a smaller quantity of fuel is injected into the cylinder compared to the baseline condition and will lead to proportionally less PM being formed.

As well as this, in order to maintain engine load with the induction of EGR the charge mass must be increased by raising the intake manifold pressure. The rate of mass transfer (and therefore kinetic energy) through the intake valve must be higher than for the baseline case. The influence of greater charge motion could be improved mixing, fuel vapourisation and charge homogeneity. Although this effect is difficult to quantify without thorough experimental or simulation effort, it could feasibly be leading to an incremental reduction of locally fuel rich regions where particles are formed.

A clear reduction in PM formation occurs with REGR due to the presence of hydrogen and CO. This reduction is seemingly monotonic as the reformat quality improves, i.e. the hydrogen and CO concentration increases. This is partly due to the decreasing proportion of the total fuel injected as gasoline, meaning that there is less liquid fuel to be vaporised and, as a result, fewer fuel droplets should remain once combustion begins. The incrementally higher combustion temperature due to higher hydrogen and CO flame temperatures will also assist in HC and PM pre-cursor oxidation.

Because of the fixed hydrogen: CO ratio in these tests is not possible to determine the individual contribution from either species on influencing PM formation. Previous research into hydrogen blended gasoline combustion [36] has indicated that hydrogen initiates a significant reduction in nucleation mode particles. Guided by work elsewhere on soot formation in ethylene-hydrogen flames [37], they concluded that hydrogen addition inhibits soot nucleation by slowing or reversing the hydrogen abstraction reaction, the mechanism by which polycyclic aromatic hydrocarbons grow to form soot. It seems likely that this route to reduced PM formation is applicable here.

Fundamental combustion studies have proven CO addition to ethylene [38] and acetylene [39] flames to be effective for reduced PM formation. Although these works derived that the chemical effect of CO is to enhance PM formation, overall PM formation was reduced due to the dominance of the dilution and thermal effects. The application of the current study differs in that the molar concentration of CO is low (<1%) and the large proportion of CO₂, H₂O and nitrogen in the charge will render the dilution and thermal effects of the CO insignificant. It is possible then that the chemical effect of CO will lead to an incremental increase in PM formation in this case, but it is offset by the presence of hydrogen.

The advanced ignition timing shift required for diluted combustion will tend to increase PM formation to some degree by allowing less time for charge mixing, meaning that more locally fuel-rich regions remain during combustion. This effect should not be as pronounced for the 'homogeneous charge' GDI engine compared with stratified charge GDI or diesel engines as the early injection timing (~295° bTDC in this case) means that the increment of time lost for charge mixing will be small relative to the overall time between injection and ignition. Ignition timing variation also alters the prevailing in-cylinder conditions during combustion and post-combustion which has a significant influence on the formation and destruction of soot pre-cursors and soot, and therefore may influence overall PM emissions more than the charge mixing effect. This will be considered in a future investigation.

Figure 6 and Figure 7 plot the particle size distributions (number and mass concentration). These are included to provide information on the influence of REGR on particle size, which is important when considering the negative health and environmental effects of PM. Particles with smaller diameter are considered more detrimental to health. The distributions show no obvious bi-modal distribution normally associated with the nucleation and accumulation modes. A similar, uni-modal particle size distribution has been seen with post-TWC exhaust sampling from a PFI gasoline engine [21]. The geometric number mean particle diameter (GNMD) for the baseline case was 58nm, and the addition of EGR reduced the GNMD to 51nm. This was due to the reduced particle formation resulting in a lower tendency to form larger particles by accumulation, rather than an increase in particles with smaller diameter. An increase in primary particles with larger diameter might reasonably be expected here because the lower post-flame temperature with EGR increases the rate of particle surface growth [19] as well as decreases the rate of particle oxidation, but this effect doesn't appear to be leading to a larger GNMD. The addition of hydrogen and CO in the charge does not influence the mean particle diameter with respect to EGR, but serves to further reduce the particle count across the range.

The concentration of particles with diameter above 200nm is very low for EGR and REGR, whereas for the baseline condition particles are measured in greater numbers up to 250nm. This effect is due to the reduced particle formation with EGR and REGR meaning there is a lower probability of agglomeration to form the larger particles. The significance of this can be seen in the particle mass distributions of Figure 7, with a greater contribution of these large particles to the total particulate mass concentration.

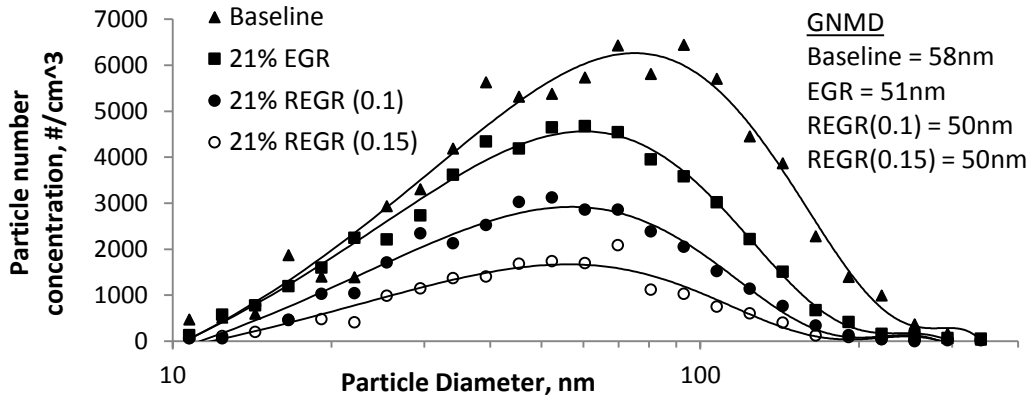

Figure 6 - Number particle size distributions for the Baseline, EGR and REGR conditions

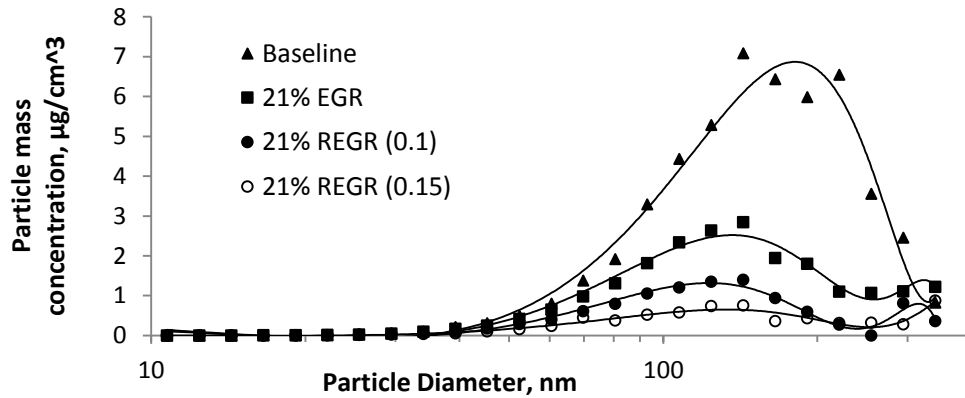

Figure 7 - Mass particle size distributions for the Baseline, EGR and REGR conditions

3.4 Estimated system efficiency

The following section provides an estimate of the total engine-reformer system efficiency, accounting for the exhaust heat recovery that might be achieved by the reforming process which is not included in the engine (indicated) efficiency calculation. First, the reforming process efficiency was calculated; this accounts for the enthalpy increase of the portion of gasoline that is converted by the reformer to gaseous fuel, and excludes any gasoline that breaks through unreacted. This approach was most suitable here because the simulated reformat contains no HC component. Therefore, HCs that would enter the combustion chamber as part of the reformat following a real reforming process were, in these tests, supplied as normal via the fuel injector. Experimental data from reformer catalyst development was applied to (8) to give an estimate of the reforming process efficiency, where LHV_x is the lower heating value of species x , $\dot{m}_{g,ref,in}$ represents the mass flow of gasoline into the experimental reformer, and the mass flows of hydrogen, CO and methane are products in the reformat. The reformer process efficiency can be considered a fuel enthalpy multiplier which represents the change in total fuel enthalpy during the reforming process, and as such may be less than or greater than 1. The reformer efficiency was calculated to be $\eta_{ref} = 1.1$ at 550°C with 5000ppm feedgas fuel.

$$\eta_{ref} = \frac{LHV_{H_2} \cdot \dot{m}_{H_2} + LHV_{CO} \cdot \dot{m}_{CO} + LHV_{CH_4} \cdot \dot{m}_{CH_4}}{LHV_g \cdot (\dot{m}_{g,ref,in} - \dot{m}_{g,ref,out})} \quad (8)$$

The estimate of engine-reformer system efficiency was then calculated using (9) for the best performing REGR condition at each load tested. Table 5 details the estimated indicated system efficiency results alongside the indicated engine efficiency ($\eta_{eng,ind}$). This relates to the engine performance as used in this study, operating with gasoline, hydrogen and CO to simulate reforming. The indicated system efficiency ($\eta_{sys,ind}$) assumes the engine operates with an integrated reformer with a reformer process efficiency of (η_{ref}) 1.1 and 1.3. The larger value represents a more optimistic value for reformer performance, which may be achieved with operation at higher temperature or following further catalyst development. Delta engine and system efficiencies ($\Delta\eta$) are relative to the baseline gasoline engine performance at each engine load, and predict the potential benefit of using a fuel reformer with a GDI engine to improve fuel efficiency.

$$\eta_{sys,ind} = \frac{\dot{W}_{ind}}{LHV_g \cdot \dot{m}_{g,eng} + \left(\frac{LHV_{H_2} \cdot \dot{m}_{H_2} + LHV_{CO} \cdot \dot{m}_{CO}}{\eta_{ref}} \right)} \quad (9)$$

Table 5 - Estimated total indicated engine-reformer system performance ($\eta_{sys,ind}$)

Engine condition	$\eta_{eng,ind}$	$\Delta\eta_{eng,ind}$	$\eta_{ref} = 1.1$		$\eta_{ref} = 1.3$	
			$\eta_{sys,ind}$	$\Delta\eta_{sys,ind}$	$\eta_{sys,ind}$	$\Delta\eta_{sys,ind}$
3 bar IMEP, 2100 rpm, 28% REGR (0.1), IVO = -10°/EVC = 8°	0.299	+7.9%	0.303	+9.1%	0.308	+11.1%
7.2 bar IMEP, 2100 rpm, 20% REGR (0.1)	0.357	+4.8%	0.360	+5.7%	0.365	+7.1%

Finally, it is well known that diluted combustion leads to lower exhaust gas temperature (EGT), which clearly has implications for the operation of an exhaust gas heated fuel reformer. For example at the 3bar IMEP engine load the EGTs (pre-turbine and post-TWC) were reduced from around 650°C for the baseline condition to 550°C for REGR. Use of REGR resulted in a slight increase in pre-turbine EGT relative to EGR (Table 4) due to higher combustion temperature. One result that wasn't anticipated was the influence of REGR on lowering the post-TWC EGT. The oxidation of unburned combustion products normally induces a rise in temperature across the TWC, but because the REGR combustion process is more complete and the exhaust contains lower HCs this effect is reduced and the resulting EGT is lower. This fact could be important for future reformer design and integration.

4. Conclusions

The potential benefits of an integrated engine-fuel reformer system have been demonstrated with these tests, which have used bottled hydrogen/CO and EGR gases to generate reformate with realistic, achievable compositions. In doing so, REGR performance was compared to that with EGR and to the baseline GDI engine.

In all cases REGR improves indicated engine efficiency relative to the baseline gasoline engine. REGR can outperform conventional EGR due to extension of the dilution limit. This is coupled with largely reduced NO_x emissions and moderately increased HCs with respect to the baseline condition. EGR and REGR also work to reduce or eliminate knock.

Both EGR and REGR reduce PM number and mass emissions across the range of studied particle diameters. The inclusion of hydrogen and CO in REGR leads to lower PM relative to EGR. The results

indicate an additive benefit is achieved by combining the mechanisms for reducing PM formation with EGR and hydrogen.

Variable cam timing offers an advantage by extending the maximum achievable REGR rate by utilising cam timings for low internal EGR. In the case of operation with an integrated, exhaust heated fuel reformer this would increase the reformed fuel fraction, maximising the potential for exhaust energy recovery.

Acknowledgments

The present work was funded by an industry and academia collaboration project, (ref. 400176/149) *CO2 Reduction through Emissions Optimisation (CREO)*, which is co-funded by the Technology Strategy Board. This project has also provided Daniel Fennell with a postgraduate scholarship.

References

- [1] Jamal Y, Wagner T, Wyszynski ML. Exhaust Gas Reforming of Gasoline at Moderate Temperatures. *Int J Hydrogen Energy*. 1996;21:pp.507 - 19. DOI:10.1016/0360-3199(95)00103-4
- [2] Leung P, Tsolakis A, Rodriguez-Fernandez J, Golunski S. Raising the fuel heating value and recovering exhaust heat by on-board oxidative reforming of bioethanol. *Energy Environ Sci*. 2010;3:780-8. DOI:10.1039/b927199f
- [3] Stone R, Zhao HY, Zhou L. Analysis of Combustion and Particulate Emissions when Hydrogen is Aspirated into a Gasoline Direct Injection Engine. 2010. [SAE Technical paper No. 2010-01-0580]. DOI:10.4271/2010-01-0580
- [4] Ji CW, Wang SF. Experimental Study on Combustion and Emissions Characteristics of a Spark Ignition Engine Fueled with Gasoline-Hydrogen Blends. *Energy & Fuels*. 2009;23:2930-6. DOI:10.1021/ef900209m
- [5] D'Andrea T, Henshaw P, Ting DSK. The addition of hydrogen to a gasoline-fuelled SI engine. *International Journal of Hydrogen Energy*. 2004;29:1541-52. DOI:10.1016/j.ijhydene.2004.02.002
- [6] Conte E, Boulouchos K. Hydrogen-enhanced gasoline stratified combustion in SI-DI engines. *J Eng Gas Turb Power*. 2008;130. DOI:10.1115/1.2795764
- [7] Alger T, Gingrich J, Mangold B. The Effect of Hydrogen Enrichment on EGR Tolerance in Spark Ignited Engines. 2007. [SAE Technical paper No. 2007-01-0475]. DOI:10.4271/2007-01-0475
- [8] Topinka JA, Gerty MD, Heywood JB, Keck JC. Knock Behavior of a Lean-Burn, H₂ and CO Enhanced, SI Gasoline Engine Concept. 2004. [SAE Technical paper No. 2004-01-0975]
- [9] Quader AA, Kirwan JE, Grieve MJ. Engine performance and emissions near the dilute limit with hydrogen enrichment using an on-board reforming strategy. 2003. [SAE Technical paper No. 2003-01-1356]
- [10] Ivanič Ž, Ayala F, Goldwitz J, Heywood JB. Effects of Hydrogen Enhancement on Efficiency and NO_x Emissions of Lean and EGR-Diluted Mixtures in a SI Engine. 2005. DOI:10.4271/2005-01-0253
- [11] Gomes SR, Bion N, Blanchard G, Rousseau S, Bellière-Baca V, Harlé V, et al. Thermodynamic and experimental studies of catalytic reforming of exhaust gas recirculation in gasoline engines. *Applied Catalysis B: Environmental*. 2011;102:44-53. DOI:10.1016/j.apcatb.2010.11.023
- [12] Fennell D, Herreros JM, Tsolakis A, Xu H, Cockle K, Millington P. GDI Engine Performance and Emissions with Reformed Exhaust Gas Recirculation (REGR). 2013. [SAE Technical paper No. 2013-01-0537]. DOI:10.4271/2013-01-0537
- [13] Bourhis G, Chauvin J, Gautrot X, de Francqueville L. LP EGR and IGR Compromise on a GDI Engine at Middle Load. *SAE Int J Engines*. 2013;6:67-77. DOI:10.4271/2013-01-0256
- [14] Cairns A, Blaxill H, Irlam G. Exhaust Gas Recirculation for Improved Part and Full Load Fuel Economy in a Turbocharged Gasoline Engine. 2006. [SAE Technical paper No. 2006-01-0047]. DOI:10.4271/2006-01-0047
- [15] Potteau S, Lutz P, Leroux S, Moroz S, Tomas E. Cooled EGR for a Turbo SI Engine to Reduce Knocking and Fuel Consumption. 2007. [SAE Technical paper No. 2007-01-3978]. DOI:10.4271/2007-01-3978

- [16] Galloni E, Fontana G, Palmaccio R. Effects of exhaust gas recycle in a downsized gasoline engine. *Applied Energy*. 2013;105:99-107. DOI:<http://dx.doi.org/10.1016/j.apenergy.2012.12.046>
- [17] Alger T, Gingrich J, Khalek IA, Mangold B. The Role of EGR in PM Emissions from Gasoline Engines. *SAE Int J Fuels Lubr*. 2010;3:85-98. DOI:10.4271/2010-01-0353
- [18] Gu X, Huang Z, Cai J, Gong J, Wu X, Lee C-f. Emission characteristics of a spark-ignition engine fuelled with gasoline-n-butanol blends in combination with EGR. *Fuel*. 2012;93:611-7. DOI:<http://dx.doi.org/10.1016/j.fuel.2011.11.040>
- [19] Kayes D, Hochgreb S. Mechanisms of Particulate Matter Formation in Spark-Ignition Engines. 1. Effect of Engine Operating Conditions. *Environmental Science & Technology*. 1999;33:3957-67. DOI:10.1021/es9810991
- [20] Hedge M, Weber P, Gingrich J, Alger T, Khalek I. Effect of EGR on Particle Emissions from a GDI Engine. *V120-3EJ*. 2011;4:650-66. DOI:10.4271/2011-01-0636
- [21] Arsie I, Di Iorio S, Vaccaro S. Experimental investigation of the effects of AFR, spark advance and EGR on nanoparticle emissions in a PFI SI engine. *Journal of Aerosol Science*. 2013;64:1-10. DOI:<http://dx.doi.org/10.1016/j.jaerosci.2013.05.005>
- [22] Zhao HY, Stone R, Zhou L. Analysis of the particulate emissions and combustion performance of a direct injection spark ignition engine using hydrogen and gasoline mixtures. *International Journal of Hydrogen Energy*. 2010;35:4676-86. DOI:10.1016/j.ijhydene.2010.02.087
- [23] Kirwan JE, Quader AA, Grieve MJ. Fast Start-Up On-Board Gasoline Reformer for Near Zero Emissions in Spark-Ignition Engines. 2002. [SAE Technical paper No. 2002-01-1011]
- [24] Tully EJ, Heywood JB. Lean-Burn Characteristics of a Gasoline Engine Enriched with Hydrogen from a Plasmatron Fuel Reformer. 2003. [SAE Technical paper No. 2003-01-0630]
- [25] Green J, J.B. , Domingo N, Storey JME, Wagner RM, Armfield JS, Bromberg L, et al. Experimental evaluation of SI engine operation supplemented by hydrogen rich gas from a compact plasma boosted reformer. 2000. [SAE Technical paper No. 2000-01-2206]
- [26] Ji C, Dai X, Ju B, Wang S, Zhang B, Liang C, et al. Improving the performance of a spark-ignited gasoline engine with the addition of syngas produced by onboard ethanol steaming reforming. *International Journal of Hydrogen Energy*. 2012;37:7860-8. DOI:<http://dx.doi.org/10.1016/j.ijhydene.2012.01.153>
- [27] Allgeier T, Klenk M, Landefeld T, Conte E, Boulouchos K, Czerwinski J. Advanced emission and fuel economy concept using combined injection of gasoline and hydrogen in SI engines. 2004. [SAE Technical paper No. 2004-01-1270]
- [28] Isherwood KD, Linna JR, Loftus PJ. Using on-board fuel reforming by partial oxidation to improve SI engine cold-start performance and emissions. 1998. [SAE Technical paper No. 980939]
- [29] Alger T, Mangold B. Dedicated EGR: A New Concept in High Efficiency Engines. *SAE Int J Engines*. 2009;2:620-31. DOI:10.4271/2009-01-0694
- [30] Samuel S, Hassaneen A, Morrey D. Particulate Matter Emissions and the Role of Catalytic Converter During Cold Start of GDI Engine. 2010. 2010-01-2122]. DOI:10.4271/2010-01-2122
- [31] Alger T, Gingrich J, Roberts C, Mangold B, Sellnau M. A High-Energy Continuous Discharge Ignition System for Dilute Engine Applications. 2013. 2013-01-1628]. DOI:10.4271/2013-01-1628
- [32] Alger T, Chauvet T, Dimitrova Z. Synergies between High EGR Operation and GDI Systems. *SAE Int J Engines*. 2008;1:101-14. DOI:10.4271/2008-01-0134
- [33] Duchaussoy Y, Lefebvre A, Bonetto R. Dilution Interest on Turbocharged SI Engine Combustion. 2003. 2003-01-0629]. DOI:10.4271/2003-01-0629
- [34] Shinagawa T, Okumura T, Furuno S, Kim K-O. Effects of Hydrogen Addition to SI Engine on Knock Behavior. 2004. 2004-01-1851]. DOI:10.4271/2004-01-1851
- [35] Eastwood PG. *Critical Topics in Exhaust Gas Aftertreatment: Research Studies Press Limited; 2000.*
- [36] Zhao H, Stone R, Zhou L. Analysis of the particulate emissions and combustion performance of a direct injection spark ignition engine using hydrogen and gasoline mixtures. *Int J Hydrogen Energy*. 2010;35:11-. DOI:10.1016/j.ijhydene.2010.02.087

- [37] Guo H, Liu F, Smallwood GJ, Gülder ÖL. Numerical study on the influence of hydrogen addition on soot formation in a laminar ethylene–air diffusion flame. *Combustion and Flame*. 2006;145:324-38.
DOI:<http://dx.doi.org/10.1016/j.combustflame.2005.10.016>
- [38] Guo H, Thomson KA, Smallwood GJ. On the effect of carbon monoxide addition on soot formation in a laminar ethylene/air coflow diffusion flame. *Combustion and Flame*. 2009;156:1135-42.
DOI:<http://dx.doi.org/10.1016/j.combustflame.2009.01.006>
- [39] Jiang Y, Qiu R. Numerical Analysis of the Effect of Carbon Monoxide Addition on Soot Formation in an Acetylene/Air Premixed Flame. *Acta Physico-Chimica Sinica*. 2010;26:2121-9.