

# Multilayer ferroelectret-based energy harvesting insole

Shi, J. , Zhu, D. , Cao, Z. and Beeby, S. P.

Published PDF deposited in [Curve](#) March 2016

**Original citation:**

Luo, Z. , Zhu, D. and Beeby, S. P. (2015) Multilayer ferroelectret-based energy harvesting insole. Journal of Physics: Conference Series, volume 660 (1): 012118

URL: <http://dx.doi.org/10.1088/1742-6596/660/1/012118>

DOI: 10.1088/1742-6596/660/1/012118

Publisher: IOP Publishing

**Content from this work may be used under the terms of the Creative Commons Attribution 3.0 licence. Any further distribution of this work must maintain attribution to the author(s) and the title of the work, journal citation and DOI.**

**Copyright © and Moral Rights are retained by the author(s) and/ or other copyright owners. A copy can be downloaded for personal non-commercial research or study, without prior permission or charge. This item cannot be reproduced or quoted extensively from without first obtaining permission in writing from the copyright holder(s). The content must not be changed in any way or sold commercially in any format or medium without the formal permission of the copyright holders.**

**CURVE is the Institutional Repository for Coventry University**

## Multilayer ferroelectret-based energy harvesting insole

This content has been downloaded from IOPscience. Please scroll down to see the full text.

2015 J. Phys.: Conf. Ser. 660 012118

(<http://iopscience.iop.org/1742-6596/660/1/012118>)

View [the table of contents for this issue](#), or go to the [journal homepage](#) for more

Download details:

IP Address: 194.66.32.16

This content was downloaded on 29/03/2016 at 16:30

Please note that [terms and conditions apply](#).

# Multilayer ferroelectret-based energy harvesting insole

Z Luo<sup>1</sup>, D Zhu<sup>1,2</sup> and S P Beeby<sup>1</sup>

<sup>1</sup>Electronics and Computer Science, University of Southampton, Southampton, SO171BJ, UK

<sup>2</sup>School of Computing, Electronics and Maths, Faculty of Engineering, Environment and Computing, Coventry University, Coventry, CV15FB, UK

E-mail: z.luo@soton.ac.uk

**Abstract.** This paper reports a flexible energy harvesting insole made of multilayer ferroelectrets, and demonstrates that this insole can power a wireless signal transmission. We have previously studied the energy harvesting characteristics of single and 10-layer ferroelectrets under compressive forces with quantified amplitudes and frequencies. In this work, we fabricate a flexible insole using multilayer ferroelectrets, and increase the number of layers from 10 up to 80, then use this insole to harvest energy from footsteps. We use this insole to power a commercial ZigBee wireless transmitter, and successfully demonstrate that an 8-bit data transmission can be solely powered by the energy harvested from this insole for every 3 to 4 footsteps. It confirms the anticipation from our previous work that the multilayer ferroelectrets are capable of powering the start-up and transmission of a low-power chipset, and shows a potential of using this energy harvesting insole in wearable applications.

## 1. Introduction

Ferroelectret is a thin and flexible cellular polymer foam that generates electric pulses under mechanical force [1,2], can be used as both a sensor and an energy harvester. When used as an energy harvester, the electric pulses from deforming the ferroelectret can charge a capacitor and power the electronics. Our previous study [3] has investigated the energy harvesting ability of porous polypropylene (PP), which is one of most researched ferroelectrets [1, 4, 5]. The PP ferroelectret is a polymer film with thickness of only 70 to 80  $\mu\text{m}$ , and Young's modulus of about 1 MPa in the thickness direction [6, 7]. This soft polymer nature and small thickness make it suitable to be used in an insole for harvesting power while maintaining comfort. However, a single layer of PP ferroelectret can only produces 1.12  $\mu\text{J}$  of energy under 800 N of compressive force [3]. This output is not enough to power any commercial low-power chipsets at present. Therefore, we designed a multilayer structure of ferroelectret to improve its output power. Using an electrodynamic instrument to apply a waver function of compressive forces, we demonstrated that a 10-layer PP ferroelectret can produce more than 10 times of energy compared to a single layer [3].

Our previous work anticipates that the multilayer ferroelectret could be capable of powering the start-up and transmission a low-power chipset [3], in this work we fabricate a ferroelectret insole and integrate it with a wireless transmitter, to show that a wireless transmission can be powered solely by the energy harvesting insole that harvests power from footsteps. This insole is made by inserting a multilayer ferroelectret into the heel. The tested multilayer samples includes 10-layer, 20-layer, 30-layer, 40-layer and 80-layer. By directly walking on this energy harvesting insole and using the generated electrical



pulses to charge a capacitor, it shows that an 80-layer ferroelectret insole can produce more than 100  $\mu\text{J}$  of energy from every footstep. A prototype has been made by connecting this 80-layer insole with a power conditioning circuit and a commercial ZigBee wireless transmitter. It shows that for every 3 to 4 footsteps, the transmitter gains sufficient energy from the insole and is able to send an 8-bit wireless signal to its receiver, which is within 8 meters from the source.

## 2. Experimental

The PP ferroelectret films were commercially purchased from Emfit Ltd. These commercial samples have been charged by the manufacturer. They were sheets in the size of 230 mm  $\times$  210 mm, with thickness of 70  $\mu\text{m}$ . These films were further cut into testing samples with size of 60 mm  $\times$  70 mm. Ag electrodes were printed on both sides of the samples using a screen printer (Dek 248, Dek Printing Machines Ltd). The Ag printing solution was silver Fabinks TC C40001 from Smart Fabric Inks Ltd. The electrode has an area size of 50 mm  $\times$  60 mm. The samples after electrode printing were cured in an oven at a temperature of 50°C for 10 minutes.

The multilayer ferroelectret was fabricated by stacking layers of electroded PP ferroelectrets with bonding films in between each two layers. These bonding films were used both for insulation and bonding to improve the synchrony of the output electrical signals. The stacked ferroelectret layers were then connected in parallel. A schematic diagram of the fabrication process is shown in Figure 1.

The multilayer ferroelectret was directly inserted into the heel of a shoe. In the test a person with weight of 80 kg walked wearing with this shoe. The generated pulses from the energy harvesting insole were used to charge a capacitor, and the capacitor voltage was monitored by a data logger (KUSB3102, Keithley Instruments Ltd). The wireless transmission powered by the energy harvester was demonstrated using a self-built power conditioning circuit and a ZigBee RF transceiver module.

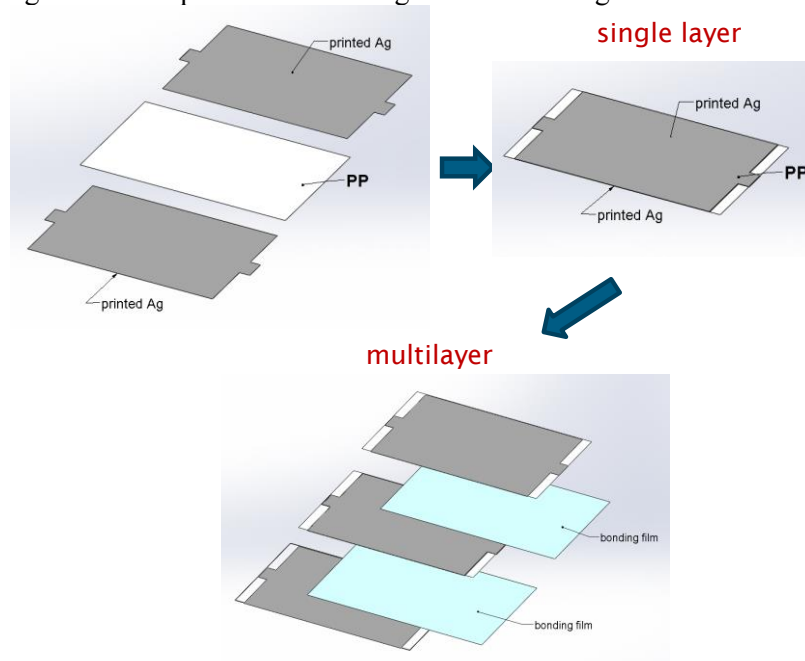

**Figure 1.** Fabrication process of multilayer ferroelectret

## 3. Results and discussion

### 3.1. Energy output from the ferroelectret insole

Insole samples with 10-layer, 20-layer, 30-layer, 40-layer and 80-layer of PP ferroelectrets are tested in this work. During the walking test, the electrical pulses generated from the ferroelectret insole are rectified and used to charge a 2.2  $\mu\text{F}$  capacitor. The voltage of the capacitor during charging is recorded

by the data logger and shown in Figure 2a. From Figure 2a, it can be clearly observed that one footstep results in an increase of the voltage, then the voltage remains no change in the interval before next footstep. This stepping shape of the charging curve shows the change in the capacitor voltage from one footstep. Using the equation  $E = \frac{1}{2}CV^2$ , where  $C$  is the capacitance of the capacitor,  $V$  is the voltage of the capacitor, the energy  $E$  in the capacitor is calculated and shown in Figure 2b. Similarly, the change in charged energy from each footstep is observed. It shows that for every single footstep, the 10-layer, 20-layer, 30-layer, 40-layer and 80-layer ferroelectret insoles charge 19.8  $\mu\text{J}$ , 31.9  $\mu\text{J}$ , 40.2  $\mu\text{J}$ , 65.6  $\mu\text{J}$  and 100.9  $\mu\text{J}$  of energy respectively into a capacitor. The 80-layer insole consists 8 times of ferroelectret layers compared to the 10-layer one, but the generated energy of the former is only 5.1 times of the latter. This shows that the generated energy does not increase linearly with the number of layers. This is due to the fact that the stresses distributed between each stacked layer are uneven, which the stress sustained by the ferroelectret layers in the bottom of the insole decreases as the number of layers increase. This has been shown by both the simulation and experimental results in our previous work [3]. It is also worth mentioning that ferroelectret insole can lose more than 50% of efficiency during capacitor charging. Therefore, the energy generated by the insole are in fact higher than the one that estimated by the capacitor charging in Figure 2.

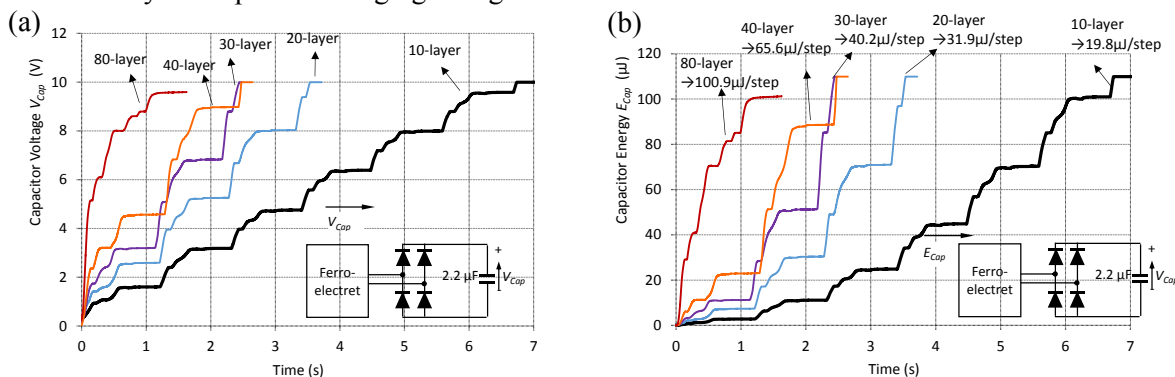
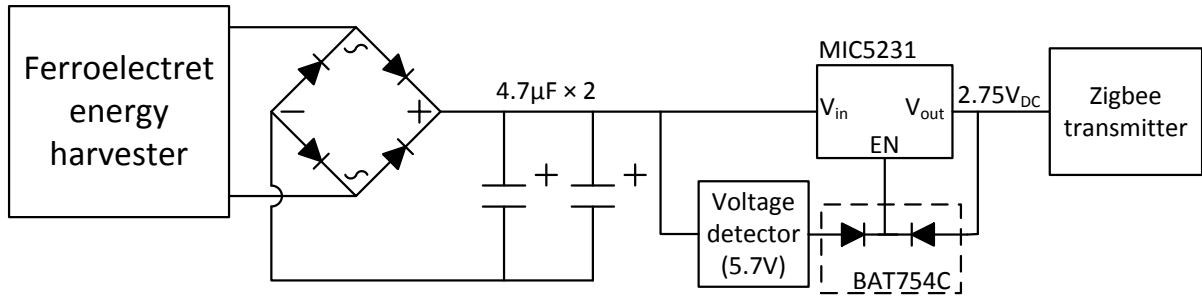

**Figure 2.** (a) Voltage charging curve of a 2.2  $\mu\text{F}$  capacitor charged by 10, 20, 30, 40 and 80 layers of ferroelectrets. (b) Energy charging curve of a 2.2  $\mu\text{F}$  capacitor charged by 10, 20, 30, 40 and 80 layers of ferroelectrets

### 3.2. Wireless transmission powered by the ferroelectret insole

It is estimated that the commercial ZigBee wireless transmitter consumes more than 100  $\mu\text{J}$  of energy per transmission. Since the 80-layer insole generates about 100  $\mu\text{J}$  of energy per footstep when charging a capacitor, it is selected to be tested for powering the transmission in this work. The energy generated from the ferroelectret insole will need to be regulated first before powering the transmitter. The circuit diagram of the power conditioning circuit is shown in Figure 3. In this circuit the output of the ferroelectret energy harvester is rectified by a bridge rectifier and used to charge two 4.7  $\mu\text{F}$  electrolytic capacitors. Once the voltage on both capacitors reach 5.7V, the voltage regulator MIC5231 is enabled and kept on until the input voltage is dropped below its output voltage of 2.75V. The threshold voltage of the voltage detector can be changed if different operation voltage range is required. The output of the voltage regulator is then used to power the ZigBee transmitter. The actual circuit layout is shown in Figure 4.

Figure 5 shows the ferroelectret insole connecting the power conditioning circuit and the ZigBee transmitter. The wireless transmission is monitored by a receiver within 8 meters from the transmitter. A LED on the receiver will turn off when an 8-bit data is received. When walking on the ferroelectret insole, the LED light turns off for every 3 to 4 footsteps, indicating a wireless transmission has been powered by the insole. This result also suggests that the harvested energy loses more than 50% during the power conditioning, since 300 to 400  $\mu\text{J}$  of energy is generated from the insole for 3 to 4 steps, only about 150  $\mu\text{J}$  is fed into the transmitter.



**Figure 3.** Circuit diagram of the power conditioning circuit

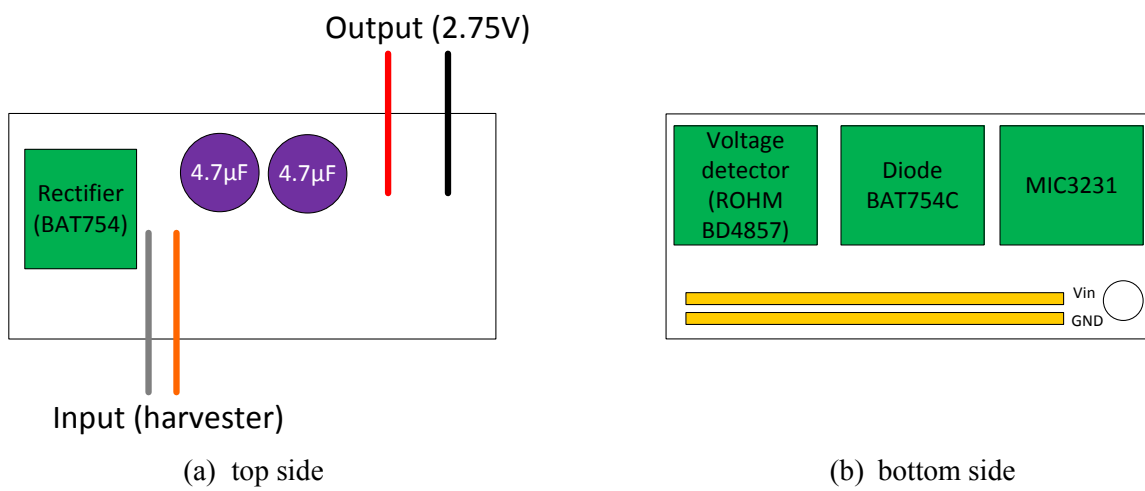

**Figure 4.** Layout of the power conditioning circuit

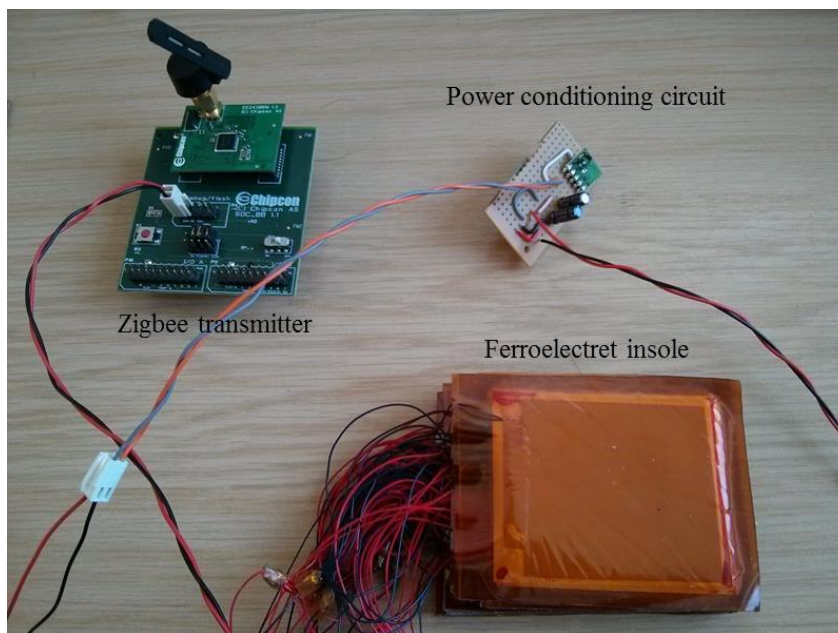

**Figure 5.** Ferroelectret insole connecting to the power conditioning circuit and the ZigBee transmitter

#### 4. Conclusion and future work

This paper reports the design and test of an insole energy harvester made of multilayer ferroelectrets, and demonstrates the wireless transmission that powered by this insole. Experimental results shows that an 80-layer ferroelectret insole can generate more than 100  $\mu\text{J}$  of energy per footstep when charging a capacitor. This insole is used to power a commercial ZigBee transmitter. It is demonstrated that for every 3 to 4 footsteps, the energy harvested from the insole is able to power an 8-bit wireless data transmission. The next step forward will be to improve the energy output from the ferroelectret insole and reduce the energy loss during power conditioning

#### 5. Reference

- [1] Hillenbrand J and Sessler G M 2000 Piezoelectricity in cellular electret films *IEEE Trans. Dielectr. Electr. Insul.* **7** 537-42
- [2] Neugschwandtner G S, Schwodiauer R, Bauer-Gogonea S, Bauer S, Paajanen M, and Lekkala J 2001 Piezo-and pyroelectricity of a polymer-foam space-charge electret *J. Appl. Phys.* **89** 4503-11
- [3] Luo Z, Zhu D, Shi J, Beeby S P, Zhang C, Proynov P and Stark B 2015 Energy harvesting study on single and multilayer ferroelectret foams under compressive force *IEEE Trans. Dielectr. Electr. Insul.* **22** 1360-68
- [4] Bauer S, Gerhard-Multhaupt R and Sessler G M 2004 Ferroelectrets: Soft electroactive foams for transducers *Phys. Tod.* **57** 37-43
- [5] Paajanen M, Lekkala J and Kirjavainen K 2000 ElectroMechanical Film (EMFi) — a new multipurpose electret material *Sens. Actuat. A: Phys.* **84** 95-102
- [6] Zhang X, Sessler G M and Wang Y 2014 Fluoroethylenepropylene ferroelectret films with cross-tunnel structure for piezoelectric transducers and micro energy harvesters *J. Appl. Phys.* **116**, 074109 (8pp)
- [7] Neugschwandtner G S, Schwodiauer R, Vieytes M, Bauer-Gogoena S, Bauer S, Hilenbrand J, Kressmann R, Sessler G M, Paajanen M and Lekkala J 2000 Large and broadband piezoelectricity in smart polymer-foam space-charge electrets *Appl. Phys. Letts.* **77**, 3827-29

#### Acknowledgments

This work was performed under the SPHERE IRC funded by the UK Engineering and Physical Sciences Research Council (EPSRC), Grant EP/K031910/1.