

# Use of Single Board Computers as Smart Sensors in the Manufacturing Industry

Gómez, A. , Cuiñas, D. , Catalá, P. , Xin, L. , Li, W. , Conway, S. and Lack, D.

Published PDF deposited in [Curve](#) January 2016

**Original citation:**

Gómez, A. , Cuiñas, D. , Catalá, P. , Xin, L. , Li, W. , Conway, S. and Lack, D. 'Use of Single Board Computers as Smart Sensors in the Manufacturing Industry' In: Procedia Engineering, 'MESIC Manufacturing Engineering Society International Conference 2015.'. at . Elsevier, 153-159.

DOI: 10.1016/j.proeng.2015.12.461

URL: <http://dx.doi.org/10.1016/j.proeng.2015.12.461>

Publisher: Elsevier

Creative Commons Attribution License

**Copyright © and Moral Rights are retained by the author(s) and/ or other copyright owners. A copy can be downloaded for personal non-commercial research or study, without prior permission or charge. This item cannot be reproduced or quoted extensively from without first obtaining permission in writing from the copyright holder(s). The content must not be changed in any way or sold commercially in any format or medium without the formal permission of the copyright holders.**

**CURVE is the Institutional Repository for Coventry University**

<http://curve.coventry.ac.uk/open>



The Manufacturing Engineering Society International Conference, MESIC 2015

## Use of Single Board Computers as Smart Sensors in the Manufacturing Industry

A. Gómez<sup>a</sup>, D. Cuiñas<sup>a,\*</sup>, P. Catalá<sup>a</sup>, L. Xin<sup>b</sup>, W. Li<sup>b</sup>, S. Conway<sup>c</sup>, D. Lack<sup>c</sup>

<sup>a</sup>Fundació Privada Centre CIM, c/Llorens i Artigas 12, 08028, Barcelona

<sup>b</sup>Faculty of Engineering & Computing, Coventry University, Priory Street, CV1 5FB UK, Coventry

<sup>c</sup>NIFES Consulting Group, Sinderland Road, WA 14 5HQ, Broadheath Altrincham

---

### Abstract

The continuously growing presence of cyber-physical systems in the industry, especially in the field of processes automation and control, represents the paradigm of the so called fourth industrial revolution, in which the systems are smarter, faster and more optimized by means of artificial intelligence, control systems and sensors networks. The presence of ICT and automation systems guarantees energy and other resources efficiency along the whole value chain of industrial processes. Especially important is the case of the smart sensors, in which a conventional sensor is equipped with interfacing methodologies for signal processing and decision making. In this article the capabilities of using a single board computer as a smart sensor are explored.

© 2015 The Authors. Published by Elsevier Ltd. This is an open access article under the CC BY-NC-ND license (<http://creativecommons.org/licenses/by-nc-nd/4.0/>).

Peer-review under responsibility of the Scientific Committee of MESIC 2015

*Keywords:* Manufacturing; Smart sensors; ICT; Control systems

---

### 1. Introduction

Manufacturing companies are adopting energy and carbon saving strategies based on intelligent systems for management, monitoring and control the production processes. These strategies rely on the development and adaptation of ICT solutions, software and hardware, along the value chain. A family of sensors has been developed to provide a precise control over the energy use in real time, allowing the development of energy sustainability

---

\* Corresponding author. Tel.: +34 934017171

E-mail address: [dcuinias@fundaciocim.org](mailto:dcuinias@fundaciocim.org)

programs. The concept “Smart Sensor” [1] represents the next generation of sensors, since these sensors incorporate analogic/digital sensors with a processor, a memory and a network controller in a common platform, allowing the possibility of pre-processing the values measured, reporting data with digital signals and communication protocols, enabling decision making systems based on pre-established conditions or remembering calibration or configuration parameters among other capabilities.

The utilization of single board computers for monitoring in different fields has been documented in a number of works, including environmental applications [3-6], smart artificial vision systems [7] or smart appliances [8] and smart cities [9]. One of the most popular single board computers is the Raspberry Pi whose easiness of use permitted a wide use of this platform for teaching activities and “do it yourself” developments. The utilization of the Raspberry Pi as a smart sensor was also demonstrated [3], [5] yet its capabilities were limited when used to collect analog data since this platform counts on digital GPIO pins. This fact required the integration with another platform like an Arduino.

There is a wide family of single board computers with different characteristics oriented to different purposes. In this paper the development of a wireless smart sensor applied for industrial environments and based on a new family of inexpensive single-board computers is presented. The computer selected is a pcDuino. The main advantage that brings is the availability of GPIO pins and analog channel inputs, thus, making unnecessary the utilization of a secondary platform such as an Arduino for collecting analog data. The system is designed to collect measures of power consumption in machines and transmit the information to an external web server via WIFI to display the data remotely to any kind of device (PC, tablet, phone). A schematic representation of the system developed here is presented in figure 1.

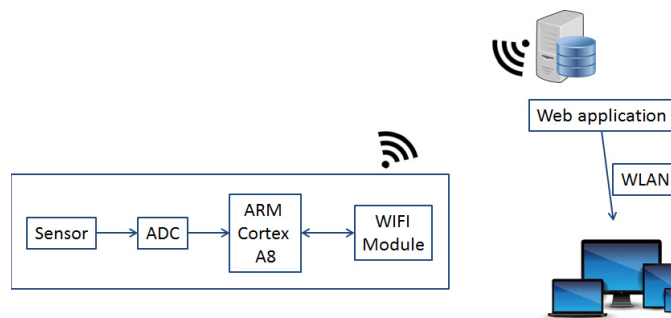

Fig 1. Conceptual architecture of the data acquisition system

## 1. Experimental procedure

The concept of the smart sensor developed relies on the utilization of a pcDuino as data acquisition system communicated with external platforms for data management and storage. This feature is interesting due to the possibility of confluence with monitoring software platforms of habitual use in the industry such as SCADAS, Manufacturing Execution Systems (MES) or Energy Management Systems (EMS). The communication of the data acquisition systems with external servers come in the form of native wireless communication solutions (WIFI in this case).

### 1.1. Hardware design

For the core processor of the smart sensor a pcDuino V2 single board computer (Figure 2) was used. This is a high performance, cost effective mini (125mm X 52mm) PC platform that runs full-featured operating systems based on Linux architecture and incorporates a built in WI-FI module and counts on 1GB DRAM ARM Cortex A8 CPU. The pcDuino has support for a number of programming languages including C/C++, Java and Python. The

advantage of using a pcDuino as the core of the smart sensor relies on the possibility of managing different sensors with the same platform, the availability of pre-processing the data gathered and the storage of historic data in a memory card (the memory card used was a 8GB microSD). This hardware platform incorporates six ADC pins to convert analog to digital signals and 14 digital I/O pins. The analog input on the pcDuino is done through six dedicated pins labeled as A0-A5 on the headers. The A0 and A1 are six-bit inputs, returning a value from 0-63 over a range from 0-2V; the A2-A5 are 12-bit inputs operating across the full 3.3V range.

The system is completed with a split core current transducer to take measures of current that gathers analogic signals from the machine under study (figure 3a). For the conversion to digital signal, the transducer was connected to the A2 pin of the ADC pin set of the pcDuino. A switching power supply of 15 W was used to feed the pcDuino (to pins 5V DC and GND).

The pcDuino works as a sensor node, serving the data collected to a database using the WIFI module incorporated by the pcDuino (see figure 3b). The communication by WIFI was selected for convenience, yet other wireless communication systems can be used (Bluetooth, ZigBee, Infrared) using an adequate shield.

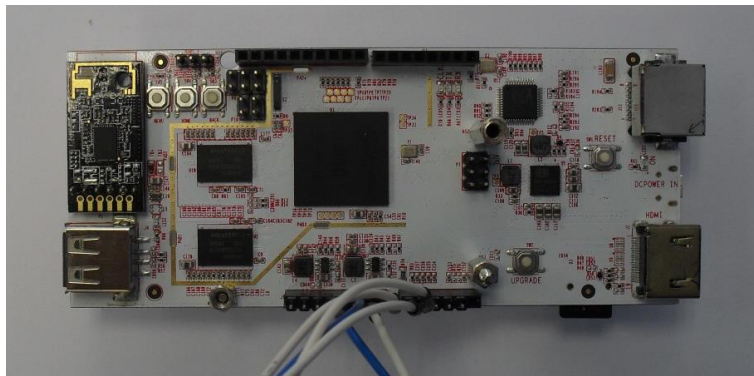

Fig 2. Single board PC used for in the smart sensor: pcDuino V2.

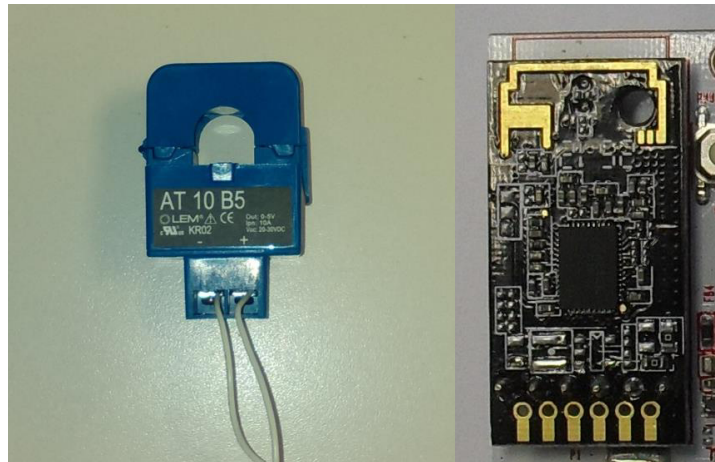

Fig 3. a) Split core current transducer. b) WIFI module incorporated in the pcDuino V2.

### 1.2. Data acquisition application development

The pcDuino incorporates an opensource operating system based on Linux and compatible with low level programming languages such as C/C++ or Python. The implementation of the pcDuino as smart sensor relies strongly on software development based on opensource libraries. A data acquisition algorithm was written in Python (v3.4.1) to read pin A2 of the pcDuino, in which the current transducer is connected, and convert the data to real current:

$$I = \frac{V_{pinA2}}{4096} * 3.3(V) * \frac{1}{800(\Omega)} * 2000 * 1000 * \frac{1}{\sqrt{2}} \quad (1)$$

Where  $V_{pinA2}$  is the value taken on pin A2 of the pcDuino

4096 is  $2^{12}$  (12 bits analog-digital converter)

3.3V is the reference voltage of the pcDuino on pin A2

$800\Omega$  is the internal resistance of the split core current transducer

2000 is the number of loops inside the current transducer (multiplied by 1000 to convert to mA)

$\frac{1}{\sqrt{2}}$  represents the effective value of the current.

The system gathers measures of current periodically. As a first prototype we consider a constant voltage of 220V to convert the data to power consumption. This procedure although not realistic is approximate and will serve to validate the smart sensor when compared with a commercial standard data logger. The sampling frequency of the data acquisition system depends on the speed of the CPU of the pcDuino, the velocity to access to the ADC pin and the type of language used (python in this case). The sampling frequency of the system was setup to 700 Hz.

The data harvesting routine is as follows: the python application reads the data from the A2 pin and sends these data to a specific port in the local IP address of the pcDuino via sockets, generating a xml file. After this, the external webservice access the public IP of the pcDuino via http and reads the data collected. An application in the web server is used to display the measurements, statistics and graphics in real time. The SD card of the pcDuino is used as a temporal backup utility of the data collected to avoid loses in case of internet failure.

### 1.3. Webservice implementation

A web server was implemented to have a ubiquitous availability of the results (measures, statistics and graphics) by communication with a MySQL database. The database is updated by a constant communication via web services written using PHP. The appearance and style of the web application was designed and created by CSS (Cascading Style Sheet). The data gathered by the system was serialized into JSON (JavaScript Object Notation) format for the communication of the server and the client.

### 1.4. Encapsulation and installation

The pcDuino was connected to a 15W power supply and encapsulated in a PVC box designed to protect the system against possible impacts. The installation of the data acquisition system required the utilization of a cable extension with open access to the three independent phases (figure 4). The machine subjected to study is plugged to the electricity grid through this cable extension and the split core current transducer is closed around one of the open cables (single phase).



Fig 4. Detail of the methodology for the current transducer installation

## 2. Results

The system was tested in a 230V lathe to provide a measure of the value of the current required and test the data acquisition algorithm. The operation selected for the lathe was the machining of a solid block of paraffin in a period of 65 seconds. The representations of the data collected by our system along the whole experiment revealed periodic zones with anomalous data acquisition corresponding to the data dump to memory. This process affects the time conversion, configuring the curling profile shown in figure 5.a. The “steps” in this curling correspond to the blank spaces in the measure of the current (figure 5.b).

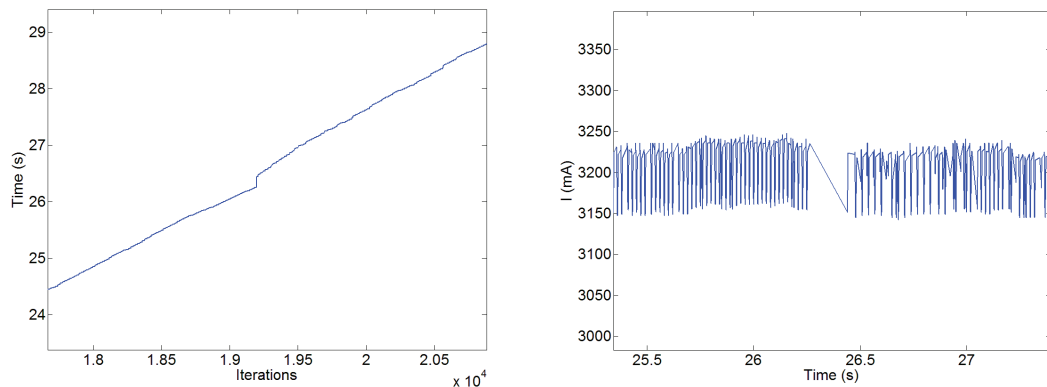

Fig 5. a) Abnormal time conversion b) Absence of data collection during data dump

In order to avoid this, the data acquisition routing was split into two threads running in parallel, one for the data acquisition and the other for the data dump, thus, smoothing the time conversion and fulfilling the blank spaces in the current data profile. The frequency of the data acquisition increases considerably, reaching ~1900 data per second.

In order to have a reference dataset a commercial data logger (Elcomponent SPC pro data logger, courtesy of NIFES) was used to compare the measures taken and calibrate the data acquisition system. Our data acquisition system showed the energy consumption of the whole operation (figure 6.a), revealing the power peak corresponding to the switching on of the machine, the stabilization around 0.7 kW and the decreasing to zero when the lathe was turned off. The calibration profile of our data acquisition system is shown in figure 6.b, where the comparison of the data gathered by our system and the commercial data logger is displayed in a time frame in which the power consumption moves through the plateau shown in figure 6.a. The red line represents the data taken by the SPC data logger and the blue line represents the data gathered by our device. The oscillations in the power consumption come from variations in the current of 0.2 A, generating the profile shown in figure 6.b. The agreement of the two dataset confirms the usability of the algorithm used. The frequency of our data acquisition system was reduced to 4 measurements per second to compare with the commercial SPC data logger.

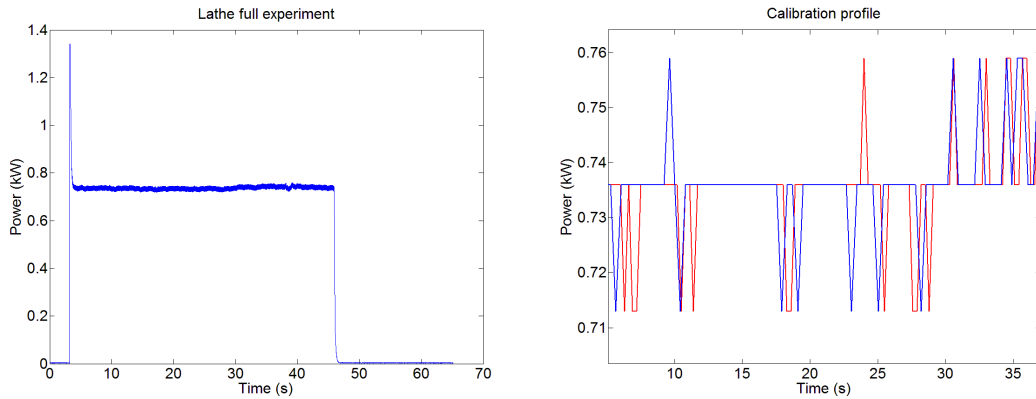

Fig 6. a) Measure of the power used by the lathe in the whole experiment. b) Comparison of the measures of power consumption of the lathe by the SPC data logger (red line) and the pcDuino (blue line).

Once the capabilities of the measuring system were tested, the next step was to enable the webserver to display the measures taken remotely and in real time. The layout with the measures of the two machines is shown in figure 7. As commented above, a user-friendly intuitive web application was designed in CSS to show the behavior of the machine measured. The database can be accessed to consult the real time data or to select a timeframe to show specific data.

The next step was the preparation of the webserver for a remote monitoring of the power consumption of the different machines. A set of machines was included in the web application: a lathe, a drill and a number of different 3D printers. The application incorporates one tab for each machine so that the user can consult the status (on/off), the instant power consumption with a round power meter and a customizable historic consumption whose timeframe can be selected in the web application.



Fig 7. Web interface of the data acquisition system

### 3. Conclusions and next steps

In this paper, a wireless smart sensor based on inexpensive hardware components and opensource software packages was presented. The utilization of the pcDuino as the architecture support of the smart sensor brings several advantages including its compactness, a wireless connection that can rely on Bluetooth, infrared, ZigBee or WIFI, a powerful processor, an easy setup of the acquisition system based uniquely on software development that can be developed in a number of programming languages (python, C/C++, Java, etc), its scalability and easiness to deploy and its low price. A web server was implemented to store and display the data collected by the smart sensor.

As a result of the developments realized in the work presented in this paper, a first prototype of a wireless smart sensor system was successfully produced, adapted for a single phase current measurement. A commercial data logger was used to calibrate the smart sensor and provide comparative measures. A user friendly web application was implemented including different functionalities like real time display of the energy consumption collected by the smart sensor and an interactive database capable to select among different time periods to represent a custom historic energy consumption of a machine or set of machines. These developments show the utility of the data acquisition system developed for real time monitoring applications.

As next steps the adaptation for three phases current is under elaboration. Besides, the integration of this smart sensor into external supervision systems like SCADAS, MES or EMS is being developed, for which a Modbus TCP/IP server was successfully implemented. New functionalities exploring the capabilities of the CPU of the pcDuino are under study including backups of the measurements in case of internet failures, pre-processing of data and on-site lecture of the data collected via touch screen. Also the incorporation of instant real voltage is under development through an AC to AC power adaptor to provide a real measure of the power consumption.

### 4. Acknowledgements

This project was developed under the umbrella of the EU funded FP7 SMARTER “Sustainable Manufacturing Adaptive Services with Cloud Architecture for Enterprises” project (FP7-PEOPLE-2013-IAPP, Grant Agreement nº 610675) with the help of Coventry University (UK) and NIFES (UK), both participant partners in this project.

### 5. References

- [1] R. Taymanov, K. Sapozhnikova. What makes sensor devices and microsystems 'intelligent' or 'smart'? Intelligent Devices and Microsystems for Industrial Applications. 2014, Pages 3–26
- [2] F.C. Delicato, P.F. Pires, L. Pirmez, L. Carmo. A flexible web service based architecture for wireless sensor networks. The 23rd International Conference on Distributed Computing Systems Workshops, pp. 730-735, May 2003.
- [3] Sheikh Ferdoush, Xinrong Li. Wireless Sensor Network System Design using Raspberry Pi and Arduino for Environmental Monitoring Applications. Procedia Computer Science 34 ( 2014 ) 103 – 110
- [4] J. Yang, C. Zhang, X. Li, Y. Huang, S. Fu, M.F. Acevedo. Integration of wireless sensor networks in environmental monitoring cyber infrastructure. Wireless Networks, Springer/ACM, Volume 16, Issue 4, pp. 1091-1108, May 2010
- [5] S.M. Ferdoush. A low-cost wireless sensor network system using Raspberry Pi and Arduino for environmental monitoring applications. Master of Science Thesis, University of North Texas, 2014
- [6] Kevin Murphy, Brendan Heery, Timothy Sullivan, Dian Zhang, Lizandra Paludetti, King Tong Lau, Dermot Diamond, Ernane Costa, Noel O'Connor, Fiona Regan, A low-cost autonomous optical sensor for water quality monitoring, Talanta, Volume 132, 15 January 2015, Pages 520-527, ISSN 0039-9140, <http://dx.doi.org/10.1016/j.talanta.2014.09.045>.
- [7] Boštjan Murovec, Janez Perš, Rok Mandeljc, Vildana Sulić Kenk, Stanislav Kovačič, Towards commoditized smart-camera design, Journal of Systems Architecture, Volume 59, Issue 10, Part A, November 2013, Pages 847-858, ISSN 1383-7621, <http://dx.doi.org/10.1016/j.sysarc.2013.05.010>.
- [8] Benjamin Fabian, Tobias Feldhaus, Privacy-preserving data infrastructure for smart home appliances based on the Octopus DHT, Computers in Industry, Volume 65, Issue 8, October 2014, Pages 1147-1160, ISSN 0166-3615, <http://dx.doi.org/10.1016/j.compind.2014.07.001>.
- [9] Leccese, Cagnetti, Trinca. A smart city application: a fully controlled street lighting isle based on Raspberry-Pi card, a ZigBee sensor network and WiMAX. Sensors (Basel). 2014 Dec 18;14(12):24408-24. doi: 10.3390/s141224408.