

Cost Minimization Control for Smart Electric Vehicle Car Parks with Vehicle-to-Grid Technology

Xiaoke Su and Hong Yue, *Senior Member, IEEE* and Xu Chen

Abstract—The high demand side cost of electric vehicles (EVs) affects the wide use of EVs in practice. In this work, a electricity cost model for EVs in a smart car park has been built up, which includes key factors such as the charging and discharging costs, the battery degradation cost, the driving probability, the feed-in tariff (FIT), and the vehicle-to-grid (V2G) rebates. Each EVs' charging and discharging status are designed through an optimization route so as to minimize the car park electricity cost. Results from comprehensive simulation studies demonstrate the potential of V2G benefits for a car park system with multiple EVs subject to EV and battery characteristics, FIT and policy support.

Keywords—electric vehicle (EV); demand side cost; battery degradation; charging and discharging; vehicle-to-grid (V2G); feed-in tariff (FIT); driving probability; optimization.

I. INTRODUCTION

A. Smart Car Park and Vehicle to Grid Technology

The use of electric vehicles (EVs) provides a feasible solution to reduce pollution to environment and improve transport system energy efficiency [1]. The bidirectional power flow between EVs and the grid has enabled the vehicle to grid (V2G) technology. A number of challenges in V2G are discussed in [2] such as stress to power system and congestion in feeders, which will lead to system overload and uncontrollable load spikes. A smart EV car park is capable of controlling EVs' charging and discharging activities, so as to facilitate power flow and energy storage between vehicles and grid [3]. Private vehicles are mostly under parking status during the daytime, either at home or in public car parks [4]. Therefore, EVs can be used as energy storage systems and virtual STATCOMs [5], the latter provides a new option for transmission line protection [6]. Large quantities of vehicles parking at public car parks will also allow owners or managers of car parks to gain additional benefits through V2G technologies from various feed-in tariffs (FIT)/incentives.

The impacts of plug-in EVs on the grid have been studied in the past decade. When EVs have adequate on-board power electronics, intelligent connections to the grid, and interactive charger hardware control, they can serve as stored energy

resources and as a reserve against unexpected outages [7]. Connection to the grid, control and communication between vehicles and grid operator, and on-board/off-board smart metering are required for beneficial V2G operation [8]. The car park costs, the emissions benefits, and the impact of EVs on distribution system depend on vehicle and battery characteristics, as well as on charging and discharging strategies. When no smart charging or embedded controller is available, charge of vehicles can only be taken as loads.

Coordinated smart charging and discharging to optimize power demand appears to be the most beneficial and efficient strategy for both the grid operator and the EV owners [9]. Recent researches [8–10] show that smart charging can minimize EV impact on the power grid, help to shift load and avoid peaks, provided suitable choices are made for intelligent controls. Direct coordination of charging and discharging can be achieved by means of smart metering, control, and communication. One strategy for getting a higher return for grid operators is to offer real-time non-linear electricity pricing for charging and discharging [11]. Each vehicle can be contracted individually or as part of an aggregation. Aggregates with EVs in a group can create a larger, more manageable load for the utility [12]. These groups can act as distributed energy resources to realize ancillary services and spinning reserves. Cooperation between the grid operator and vehicle owners or aggregates is crucial to achieve high net return.

When using smart car parks, replacing traditional vehicles with EVs may impose stress to the power system and create issues such as congestion in feeders, system overload, and spikes in energy market prices if charging of EVs is not properly controlled [13]. However, the presence of EV aggregates in an area distribution network can be beneficial to a local distribution company, since aggregates can coordinate and manage the charging time of their EVs fleet. In fact, aggregates can attract EVs into their smart car parks by introducing a variety of incentives to EV owners. Consequently, activities of aggregates such as cooperating with local distribution company or taking part in different power markets such as energy, spinning reserve, and frequency regulation markets can mitigate or remove the above mentioned problems, and provide benefits to EV owners.

It has been reported that most private vehicles are parked at parking lots in idle state for more than 90% of the time during a day [14]. Therefore, these energy storage apparatuses can bring a huge potential for the aggregates' prosperity to participate in various grid-related activities. A real-time load management control strategy is proposed for coordinating the charging time of EVs in order to minimize energy losses in

This work was supported in part by the UK Engineering and Physical Sciences Research Council (EPSRC) through grant EP/R007497/1.

X. Su is with Department of Electronic and Electrical Engineering, University of Strathclyde, Glasgow G1 1XW, United Kingdom. (email:xiaoke.su@strath.ac.uk).

H. Yue is with Department of Electronic and Electrical Engineering, University of Strathclyde, Glasgow G1 1XW, United Kingdom. (email:hong.yue@strath.ac.uk). Corresponding author

X. Chen is with School of Electrical and Information Engineering, Jiangsu University, Zhenjiang 212013, Jiangsu, China. (email:xuchen@ujs.edu.cn)

a smart grid [15], in which the impact of battery degradation to profit is not considered. A model for V2G performance evaluation for micro grid energy management is presented in [16]. A method is proposed to control EVs charging in quasi-real-time for participation of EV aggregates in the energy market [17]. In [18], coordinated charging/discharging of EVs is investigated for voltage control and congestion management. A method is developed in [19] for V2G along with capacitor allocation for bus voltage improvement, loss reduction, and congestion management using an artificial immune systems based approach. In [20], EVs have been utilized to support smart grids by offering ancillary service including frequency regulation. In [21], aggregate's self-scheduling problem for participating in the spinning reserve market has been modelled using an agent-based model. A probabilistic approach is proposed in [22], based on the point estimate method, to determine the optimal capacity and location of EV parking lots in grid networks. Their work is focused on the users' behaviours and the battery degradation cost is not considered. The feasibility of V2G technology is discussed with the analysis of energy efficiency for multi-port power converters used in EVs [23]. A vehicle owner's cost is estimated to be halved by using V2G [24]. The opportunities and challenges of V2G, vehicle to home and vehicle to vehicle are investigated in [25]. A scheduling method is proposed to ensure adequate charging condition of EVs, and that the power quality of the regulation service can be stabilized [26].

The above works have provided understanding and support to V2G activities for large-scale EV systems. One factor that is lack of investigation is the impact of battery degradation to the overall EV operational costs. Other factors such as the customer behaviours and V2G rebate from the energy company policy also need to be considered systematically in an optimization framework.

B. Battery Degradation

Battery degradation cost may largely affect the use of V2G in practice [27]. Adverse factors for batteries in plug-in hybrid EVs and battery EVs include high current rates, deep discharge conditions, low and high operating temperatures [28]. For the energy storage system of any electrically propelled vehicles, the energy capacity, the power for acceleration, regenerative braking for efficiency and cycle life remain to be the critical components [29].

The relevance of fast charging under different temperatures to the battery lifetime is analysed in [30]. The main ageing parameters such as internal resistance increase and capacity fade in lithium-ion chemistries are discussed based on half-cell levels [31]. The power fade during the cycle life is studied at two different working temperatures, relating this parameter to the state of health [32]. In [33], accelerated cycle life tests are performed at different conditions on depth of discharge and temperature. Accelerated lifetime tests are performed at different working temperatures and different levels of state-of-charge (SOC) to establish a mathematical relationship between the storage time, temperature and voltage to battery ageing [34]. In another study on lithium-ion

phosphate based batteries, it is observed that the capacity fade increases with the storage temperature [35]. The lithium loss has also been identified as a main source of the capacity fade. The capacity fade at high temperatures is found to be related to the dissolution of Fe^{2+} from the $LiFePO_4$ electrode and subsequent deposition of the ions on the carbon electrode, where the metal deposit tends to catalyse the formation of the solid-electrolyte interface layer [36]. It is suggested that the most relevant parameters for battery degradation are the storage temperatures, depth of discharge, current rates and fast charging [37]. Among the various factors that are identified to affect battery degradation, in this work, the charging and discharging will be investigated as they are most relevant to EVs in a car park.

C. Main Contributions

The aim of this work is to investigate battery charging and discharging strategies for EVs in smart car park so as to minimize car park electricity cost. A model for smart EV car park will be established considering battery degradation cost as a major impact factor. Other factors such as EV battery capacity, charging speed and car park size, FIT, income of rebate, etc. will also be included in the model. With this car park model, the EV charging and discharging operations can be determined and described by on-off switching functions through an optimization design. The constraints on SOC requirements will be incorporated into the optimization.

The novelty of this work is mainly on the following two aspects. (1) An energy consumption model is established for a typical car park system with multiple EVs. In this model, both the cost of battery degradation and the income of rebate have been included, where in most previous works only one of them is considered. This model is applicable for different car park sizes and different charging methods. (2) The EV charging and discharging status are determined through optimization design with the use of an genetic algorithm (GA). New insights are obtained from the results and discussions.

The remaining of the paper is organized as follow. A smart car park model is proposed in Section II, where the EV charging and discharging status are taken as the control variables for the total electricity cost of the car park. Based on the proposed model, a case study is performed in Section III, and the discussions are made regarding the impacts of rebate, FIT, battery degradation, battery capacity, charging speed and car park size on the total electricity cost. Conclusions are made in Section IV.

II. SMART CAR PARK ELECTRICITY COST MINIMIZATION

A. Electricity Cost Model

A smart car park system in connection to power grid with and without EVs power transmission controller is illustrated in Fig. 1. In a traditional connection mode, the grid is directly connected to the charging slots and other loads. There is no feed back from the charging slots to the grid. In the controller mode, the grid and the charging slots are connected via a power transmission controller which enables the V2G activities. The EVs can not only receive power from the

TABLE
NOMENCLATURE AND ACRONYMS

Nomenclature	
N	Number of vehicles
$u_i(t)$	Charging/discharging status
C_{total}	Total cost (£)
$C_{charging}$	Cost of charging (£)
$C_{discharging}$	Cost of discharging (£)
C_{loss}	Battery degradation cost (£)
C_{rebate}	Rebate income (£)
t_0 and t_f	Start and end time (h)
Δt	Sampling time period (h)
P_{EV}	Power of EV charging and discharging (kW)
SOC_{min}	Minimum state of charge
SOC_{max}	Maximum state of charge
SOC_{final}	Final SOC requirement
$SOC(t)$	SOC at time t
$\Delta SOC_{connect}$	Change of SOC for EV plug-in at car park
c_{usable}	Battery usable capacity (kW)
i_{bat}	Current of battery (Ampere, A)
D_r	Battery degradation rate (£/kWh)
$p(t)$	Electricity price (£/kWh)
p_r	Rebate price (£/kWh)
$q(t)$	Feed-in tariff (£/kWh)
d_{max}	Maximum driving distance (mile, m)
d_d	Driving distance since fully charged (mile, m)
\bar{d}_j	Each travelled distance (mile, m)
\bar{p}_j	Probability for each travelled distance
\bar{P}	Overall probability for EV driving outside
M	Number of drivings
Acronyms	
EV	electric vehicle
FIT	feed-in tariff
GA	genetic algorithm
SOC	state of charge
V2G	vehicle to grid

grid, but also send stored energy back to the grid through the charging slots. This bi-directional energy transmission can potentially provide profit for the demand side and in the meantime help to stabilize the power system.

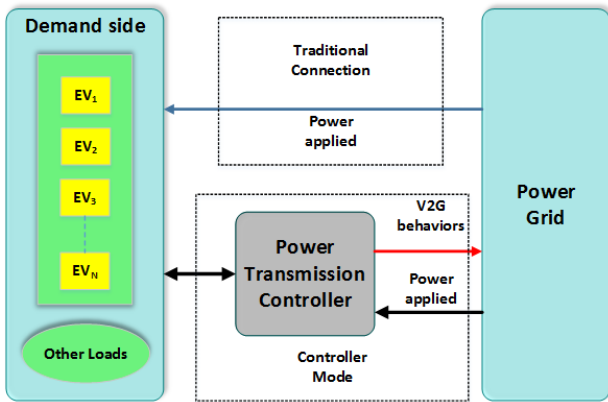

Figure 1. EV car park with power transmission controller for grid connection

An EV in a car park can have three status: charging (G2V) when the grid sells power to vehicle owners; discharging (V2G) when the grid buy extra power from vehicle owners; and disconnect when there is no power transmission between the grid and vehicle. Denoting $u(t)$ as the charging status at time t , the EV battery status can be written as

$$u(t) = \begin{cases} 1, & \text{charging} \\ -1, & \text{discharging} \\ 0, & \text{disconnect} \end{cases} \quad (1)$$

The total electricity cost, C_{total} , is considered to include four components, i.e.

$$C_{total} = C_{charging} - C_{discharging} + C_{loss} - C_{rebate} \quad (2)$$

where $C_{charging}$ and $C_{discharging}$ are the costs of charging and discharging, respectively; C_{loss} is the cost due to battery degradation during charging and discharging; and C_{rebate} is the rebate income. Here the devices investment and maintenance fees are ignored.

Define

$$sgn^+(x) = \begin{cases} 1, & \text{if } x > 0 \\ 0, & \text{if } x \leq 0 \end{cases} \quad (3)$$

From the starting time t_0 to the finishing time t_f , the EV charging cost can be calculated by

$$C_{charging} = \int_{t_0}^{t_f} p(t) \cdot sgn^+(u(t)) \cdot P_{EV} dt \quad (4)$$

where $p(t)$ is the price of electricity, P_{EV} is the power rate of charging and discharging. For simplicity, in this work, it is assumed that the electricity price is constant and P_{EV} is the same for all EVs in the car park.

Similarly, for EV discharging, $u(t) = -1$, the income over review period is calculated by

$$C_{discharging} = \int_{t_0}^{t_f} q(t) \cdot sgn^+(-u(t)) \cdot P_{EV} dt \quad (5)$$

where $q(t)$ is the FIT from grid. A fixed FIT is considered in this work.

The battery degradation cost occurs during both charging and discharging. A fixed degradation rate, D_r , is used in this model for both charging and discharging processes.

$$C_{loss} = \int_{t_0}^{t_f} D_r \cdot (sgn^+(u(t)) + sgn^+(-u(t))) \cdot P_{EV} dt \quad (6)$$

The rebate depends on the electricity sold to the grid via V2G, which is calculated by

$$C_{rebate} = \int_{t_0}^{t_f} p_r \cdot P_{EV} \cdot sgn^+(-u(t)) dt \quad (7)$$

where p_r is the rebate price.

Substituting equations (4) - (7) to (2), the final cost model can be calculated as

$$C_{total} = P_{EV} \cdot \int_{t_0}^{t_f} \{ p \cdot sgn^+(u(t)) - q \cdot sgn^+(-u(t)) + D_r \cdot (sgn^+(u(t)) + sgn^+(-u(t))) - p_r \cdot sgn^+(-u(t)) \} dt \quad (8)$$

B. Considering Plug-in Probability

We now consider the practical situation that a vehicle drives outside for several times during the review period, and the probability of plug-in to car park slots is less than 1. For a fully charged EV after driving over a distance, its battery SOC is calculated by [38],

$$SOC = 1 - \frac{d_d}{d_{max}} \quad (9)$$

where d_d is the driving distance since the fully charged status; d_{max} is the maximum range that the EV can travel. For an EV taking several drives during the monitoring period, the decrease of SOC can be calculated by considering the travel probabilities for each drive, which is given as

$$\Delta SOC_{driving} = \frac{\bar{P}}{d_{max}} \sum_{j=0}^M \bar{d}_j \bar{p}_j \quad (10)$$

where \bar{d}_j is the j -th distance travelled; \bar{p}_j is the probability corresponding to \bar{d}_j ; M is the number of drivings during the review period; $\sum_{j=0}^M \bar{p}_j = 1$, and \bar{P} is the probability of EV driving out of the car park. It means the time probability of EV staying inside the car park is $1 - \bar{P}$.

The change of SOC after EV battery charging or discharging is calculated by [39]

$$\Delta SOC_{connect} = \frac{1 - \bar{P}}{c_{usable}} \int_{t_0}^{t_f} i_{bat}(\tau) d\tau \quad (11)$$

where c_{usable} is the battery usable capacity; i_{bat} is the battery current.

Therefore, the SOC of EV battery at the end of the review period can be calculated by the following function:

$$SOC_{final} = SOC_{in} \pm \frac{1 - \bar{P}}{c_{usable}} \int_{t_0}^{t_f} i_{bat}(\tau) d\tau - \frac{\bar{P}}{d_{max}} \sum_{j=1}^M \bar{d}_j \bar{p}_j \quad (12)$$

where SOC_{in} is the initial SOC at t_0 , the sign for SOC change by charging is '+' and '-' for discharging.

By considering the probability of EV staying in the car park and driving outside, the total cost in (8) becomes

$$\begin{aligned} C_{total} = & (1 - \bar{P}) \cdot P_{EV} \cdot \int_{t_0}^{t_f} \{ p \cdot \text{sgn}^+(u(t)) \\ & - q \cdot \text{sgn}^+(-u(t)) \\ & + D_r \cdot (\text{sgn}^+(u(t)) + \text{sgn}^+(-u(t))) \} dt \\ & - P_{EV} \cdot \int_{t_0}^{t_f} p_r \cdot \text{sgn}^+(-u(t)) dt \end{aligned} \quad (13)$$

The above model is developed to calculate the electricity cost for one EV. When multiple EVs are considered in a car park, the total cost will be the sum of costs for each EV, i.e.,

$$C_{total} = \sum_{i=1}^N C_{total}^i(u_i). \quad (14)$$

C. Optimization Problem

Several constraints need to be considered for practical car park EV operations. For an EV battery, its SOC needs to stay between the required lower and upper bounds at any time, i.e.,

$$SOC_{min} \leq SOC(t) \leq SOC_{max} \quad (15)$$

where $SOC(t)$ is the SOC at time t ; SOC_{min} and SOC_{max} are the lower and upper bounds for SOC. In this work, the boundary constraints are considered to be the same for all EVs in the car park. The required SOC after the last drive each day, SOC_{final} , should satisfy

$$SOC_{final} \geq a \quad (16)$$

where a is a given threshold value.

To minimize the total electricity cost by considering constraints on EV batteries, the optimization problem can be formulated as follows.

$$\begin{aligned} u^*(t) = & \arg \min C_{total}(u(t)) \\ \text{subject to: } & SOC_{min} \leq SOC(t) \leq SOC_{max} \\ & SOC_{final} \geq a \end{aligned} \quad (17)$$

This optimization problem can be solved by using a heuristic global optimization method, Genetic Algorithm (GA), to find the best charging and discharging conditions of each vehicle over the monitoring period.

III. SIMULATION AND DISCUSSION

A. System Description

A car park in a typical office area with 50 EV charging slots is selected for the case study. Use of electricity is assessed for working hours from 9am to 5pm, divided into 32 time slots with 15 minutes each. Taking Tesla as an example, it is known to be the best sold EV in the world, with the maximum driving distance of 120 miles, the maximum SOC of 0.9 and the minimum SOC of 0.2. It is required that the SOC is no less than 0.7 at the end of day.

There are three major types of charging stations. The first one is called 'Level 1' device, often referred to as low power charging or residential charging. EVs are plugged in to low voltage receptacles with a very slow recharging rate. It takes around 15 hours or more for an average full charge. The second type is termed as 'Level 2' device which operates faster than Level 1 station by using industrial voltage power to fully charge an EV in less than 5 hours. The third type is called 'Level 3' charging station, or fast charging station, which is only available for public charging services other than residential car parks. In this work, the 'Level 2' charging, also called the industrial charging, is used as the baseline, in which the voltage is 380 volts and the charging/discharging power is 13.2 kW.

The rebate price is selected to be 0.4 £/kWh and the FIT is chosen to be 0.0485 £/kWh. According to [40], the battery degradation cost is 0.3 £/kWh. The price of power from grid is 0.28 £/kWh. These parameters are listed in Table II. The data for EV driving behaviours are taken from a survey, in which the number of drivings for each EV is either 0, 1 or 2, the five possible driving distances are [1, 2, 3, 4, 5] miles, and the probabilities associated with these five driving distances are [0.47, 0.23, 0.13, 0.12, 0.05]. In this simulation, it is assumed that probability of EV driving outside is the same for all EVs, the value is calculated from the survey data using an averaged level of $\bar{P} = 0.21$.

B. Baseline Optimization

First the optimization of charging and discharging without rebate is studied. The 50 EVs are considered to have different initial SOC, the values are randomly generated within the range of 0.2 to 0.9. The initial SOC and the optimized costs for 50 EVs are listed in Table III, and illustrated in Fig. 2.

In Fig. 2, the horizontal axis is the initial SOC; the vertical axis shows the minimum costs of each vehicle. The green

TABLE II
PARAMETER SETTING

Quantity	Value	Comment
N	50	Number of vehicles
n_x	50*32	Number of variables
a	0.7	Threshold for SOC_{final}
Δt	0.25h	sampling period
P_{EV}	13.2kw	Charging/discharging power
SOC_{min}	0.2	Minimum SOC
SOC_{max}	0.9	Maximum SOC
V	380V	Industrial electric voltage
c_{usable}	85 kW	EV battery usable capacity
p_r	0.4 £/kWh	Rebate price
D_r	0.3 £/kWh	Battery degradation rate
$p(t)$	0.28 £/kWh	Power price
$q(t)$	0.0485 £/kWh	FIT fixed rate
M	0, 1 or 2	Number of travels for each EV
d_{max}	120 miles	Maximum driving distance
\bar{p}	0.21	Probability of EV outside
\bar{d}_j	[1,2,3,4,5] miles	Distance of each EV travelled
\bar{p}_j	[0.47,0.23,0.13,0.12,0.05]	Probabilities for each distance

TABLE III
OPTIMIZED COSTS AND INITIAL SOCS

SOCin	0.61	0.6	0.86	0.25	0.65
Cost (£)	1.8	1.8	0	7.3	0.9
SOCin	0.55	0.52	0.24	0.29	0.23
Cost (£)	2.7	3.7	7.3	6.4	7.7
SOCin	0.35	0.36	0.75	0.38	0.59
Cost (£)	4.45	5.5	0	5.45	1.8
SOCin	0.42	0.5	0.66	0.84	0.57
Cost (£)	4.5	3.6	0.9	0	2.7
SOCin	0.58	0.82	0.46	0.81	0.85
Cost (£)	2.7	0	4.5	0	0
SOCin	0.64	0.21	0.68	0.22	0.32
Cost (£)	1.8	8.2	0.9	8.4	6.35
SOCin	0.76	0.54	0.88	0.51	0.37
Cost (£)	0	2.7	0	3.6	5.6
SOCin	0.74	0.43	0.79	0.53	0.31
Cost (£)	0	4.5	0	2.7	6.4
SOCin	0.67	0.87	0.77	0.3	0.28
Cost (£)	0.9	0	0	6.4	7.2
SOCin	0.48	0.78	0.81	0.71	0.26
Cost (£)	3.6	0	0	0	7.3

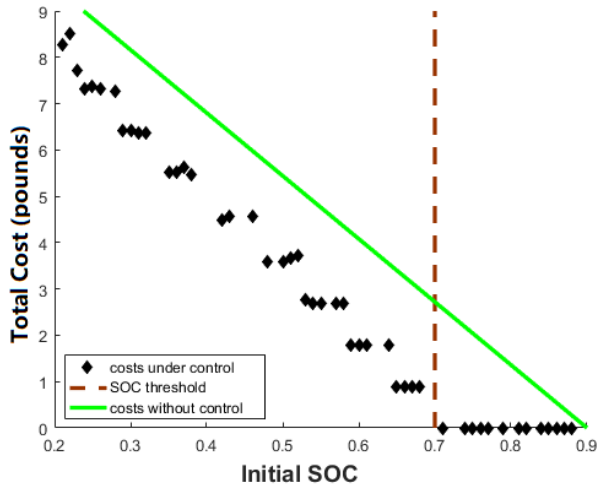

Figure 2. Comparison of total costs with and without transmission control

TABLE IV
IMPACT OF FIT AND D_r TO THE MINIMUM COST

Cost (£) \ D_r	0.3	0.25	0.20	0.15	0.10	0.05
FIT	0.06	190.2	191.4	190.2	190.2	190.2
	0.08	191.4	190.0	188.4	191.4	191.4
	0.10	194.0	188.4	192.2	193.4	152.4
	0.12	190.0	193.4	188.4	192.2	140.0
	0.14	188.4	192.2	190.0	193.4	125.4
	0.16	193.4	191.0	192.1	149.9	109.0
	0.20	192.2	193.4	168.0	136.3	97.0
	0.24	191.0	190.4	152.2	120.4	81.0
	0.26	190.4	164.4	138.8	103.7	69.1
	0.28	188.4	155.0	125.9	91.1	68.0
	0.30	168.0	144.3	119.4	77.4	58.0
	0.32	159.4	136.8	105.4	50.0	41.4

solid line is the cost without optimization control. The brown dashed line is the final SOC requirement which is set to be 70%. The black diamond markers show the minimized costs for each EVs. It can be observed that the cost by using the optimal controlled charging/discharging strategy is lower than the cost without control, especially when the initial SOC is higher than 70%. It can also be found that there are no active V2G activities when no rebate is introduced (see Table V). For those EVs with initial SOC levels higher than 70%, they are disconnected from the grid, and no charging and discharging activities take place. This is because the battery degradation cost is higher than the fixed FIT. Hence, individuals or small scale car park cannot get the profit from V2G. When the initial SOCs are close to each other among EVs, their optimized final costs also stay close, which can be clearly seen in Fig.2 and Table III.

C. Impacts of FIT and Degradation Rate without Rebate

In principle, under a given rebate price, the lower rate of degradation cost, and/or higher level of the FIT will increase the cost benefit for EV users. When the impact of battery degradation cost is more prominent compared to that of FIT, no V2G activities will take place. In the next simulation, the FIT is increased by a step of 0.02 £/kWh from its initial setting of 0.0485 £/kWh to 0.32 £/kWh, and the battery degradation cost is reduced by a step of 0.05 £/kWh from the initial value of 0.3 £/kWh to 0.05 £/kWh. The results of the optimized costs under different levels of FIT and degradation costs are shown in Table IV and Fig. 3.

When the car park system has a sufficiently high FIT and low battery degradation cost, V2G happens for those cars with higher initial SOCs. In this study, the 50 EVs are divided into two groups (see Table III), one group includes EVs which have initial SOCs higher than 70% (15 EVs, entries with bold font and underline highlight), and another one including EVs with initial SOCs lower than or equal to 70% (35 EVs). For the first group, the EV battery power can be sold to the grid in order to get overall profit, i.e., the benefit from grid is larger than the cost of battery degradation loss. For the second group, the EV batteries only get charged from the grid, and there are no discharging activities.

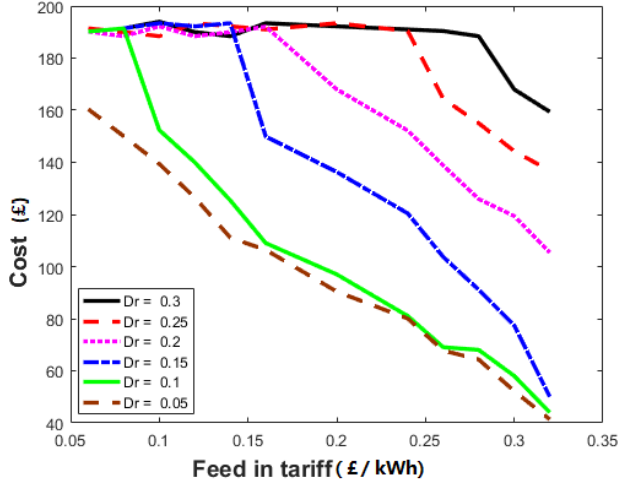

Figure 3. The change of minimum costs with respect to the FIT under different battery degradation rate

TABLE V
OPTIMIZED COSTS AND CHARGING/DISCHARGING NUMBERS WITH/OUT REBATE

	No rebate	With rebate
Minimum cost (£)	190.28	66.67
Number of -1 (discharging)	0	28
Number of 1 (charging)	142	144
Number of no transmission	1458	1428

In Fig. 3, the horizontal axis is the FIT ranged from 0.06 to 0.32 £/kWh , and the vertical axis is the minimum costs from the controlled EV charging/discharging operations. Six curves corresponding to 6 levels of degradation rates are shown in the figure, from which it can be seen that before each curve reaches the point of $FIT = D_r$, the optimized cost is mostly maintained at a constant level. This indicates there is no V2G occurred when the FIT is lower than the EV battery degradation rate. Once $FIT \geq D_r$, a decrease in the costs can be clearly seen, which means V2G takes place and helps to reduce the overall electricity cost for the car park. Those data with V2G cost reduction when $FIT \geq D_r$ are highlighted in Table IV with bold font and underline mark.

D. Impact of Rebate

The rebate is included to discuss the conditions enabling V2G benefits. In this simulation, a $\text{£}200$ cash is paid to the car park once the total V2G power reaches 500 kWh , i.e., the rebate price is $p_r = 0.4/\text{kWh}$. The results for the numbers of different charging status and the optimized costs for the car park are listed in Table V. Fig.4 and Fig.5 show the charging and discharging status with and without rebate. The horizontal axis is the index for all 50 EVs at 32 time slots, which is 1600 in total. The vertical axis is the charging/discharging status where '1' is charging, '-1' discharging, and '0' no transmission of power between EVs and the grid. When the rebate is introduced, V2G operations take place for those EVs which have higher initial SOC.

TABLE VI
REBATE AND MINIMUM COST

Rebate (£/kWh)	Cost (£)	Rebate (£/kWh)	Cost (£)
0.04	190.27	0.18	188.17
0.06	191.41	0.20	190.31
0.08	190.17	0.22	190.27
0.12	188.77	0.24	189.41
0.14	194.41	0.26	175.09
0.16	193.14	0.28	169.02

TABLE VII
IMPACT OF BATTERY CAPACITY AND CHARGING STYLE TO COSTS

Cost (£)	mode			
		Residential charging	Industrial charging	Fast charging
C_{usable}	60 kW	179.00	180.35	180.35
	80 kW	186.00	187.55	187.55
	100 kW	195.37	195.37	195.37
	120 kW	200.10	201.4	201.4

The rebate price also influences the cost benefits. In the following, the rebate rate is increased from 0.04 £/kWh to 0.28 £/kWh , with an incremental step of 0.02 £/kWh , as shown in Table VI. It shows from Table VI that there is clear decrease of costs when the rebate price reaches 0.26 £/kWh , where V2G occurs and the overall cost is reduced.

E. Impacts of Battery Capacity and Charging Style

In this section, the impacts of EV battery capacity and charging types to car park electricity cost is discussed.

The battery capacity parameter, C_{usable} , is changed from 60 kW to 120 kW with the incremental step of 20 kW. The impact of C_{usable} towards the overall cost is compared under three charging styles: residential charging, industrial charging and fast charging. Results are listed in Table VII and Fig. 6. It can be seen that the overall cost is mostly determined by the battery capacity regardless of the charging styles. When the battery capacity is increased, the overall cost is always increased. When vehicles are charged at residential power level (low speed charging), the costs are slightly lower than the other two charging modes. This is because the assessment length is 8 hours in this work, which is not long enough to fully charge an EV using the low speed charging.

By fixing other factors as in Section III-A, the number of EVs is changed from 20 to 100, the minimum costs are calculated and listed in Table VIII. It can be seen that the increase of car park size will increase the overall costs. However, the V2G activities are not affected by the change of car park size.

F. Simulation Studies on Weekly Data

In the above simulations, an 8-hour review period for one working day is considered. The initial SOC is not affected

TABLE VIII
IMPACT OF SMART CAR PARK SIZE

Number of vehicles	20	40	60	80	100
Total cost (£)	77.30	154.33	230.41	300.00	379.52

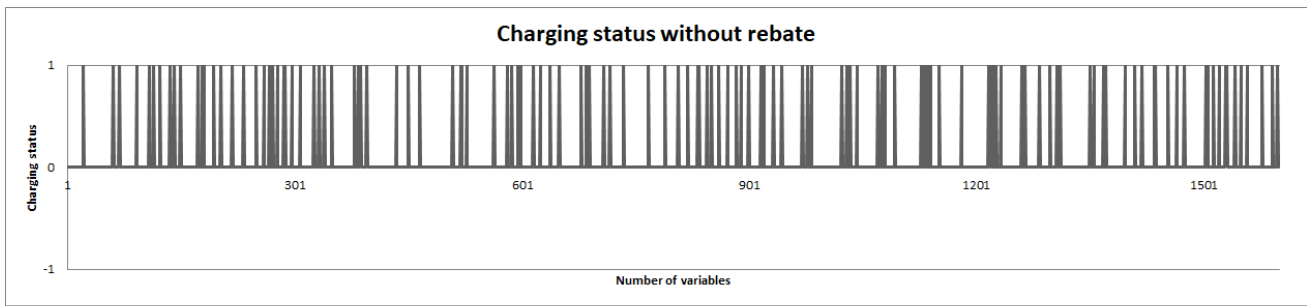

Figure 4. Charging status without rebate

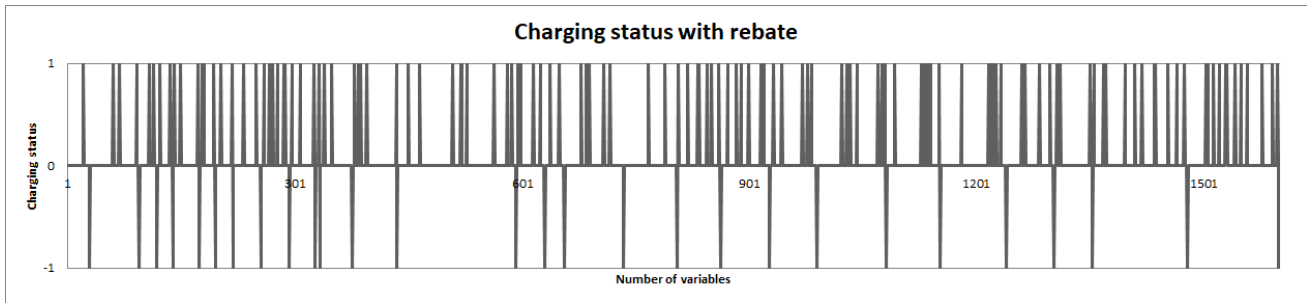

Figure 5. Charging status with rebate

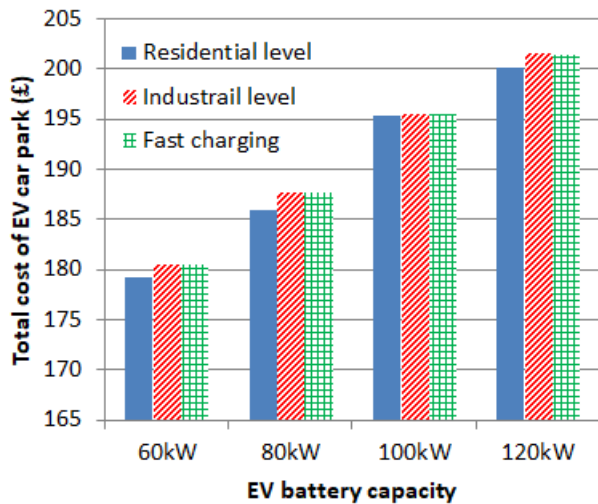

Figure 6. Impact of battery capacity to costs under three charging styles

by the final SOC in the previous day. In this section, the simulation is made on a longer time period over one week, for the same monitoring period of 9am to 5pm each day. The rebate is set to £400 when system sells 1,000kWh power to the grid. All other factors are kept as the same in Section III-A. The results in Table IX show that, there are fewer V2G activities on the first day; the smart car park needs to charge the vehicles to satisfy the SOC_{final} requirement. the other days, the system takes V2G activities to make profit.

TABLE IX
ASSESSMENT OF COSTS OVER WEEKLY PERIOD

date	costs w/o rebate (£)	costs with rebate (£)	V2G times
Sun	191.4	174.3	6
Mon	81.2	-4.2	37
Tue	80.0	-6.1	38
Wed	83.4	-4.2	37
Thu	79.8	-4.2	37
Fri	81.2	-4.2	37
Sat	80.4	-4.2	37

IV. CONCLUSION

In this work, a control method for EV charging and discharging is proposed for smart EV car park systems. The purpose is to minimize the car park electricity cost by manipulating the charging and discharging status during a review period. Results from comprehensive simulation studies suggest the potential of V2G benefits, this however, is subject to many factors such as the battery degradation cost, the rebate price, the FIT, and the initial SOC. To provide appealing FIT to EV users and improve battery performance are considered to be the main factors that would encourage V2G. The government policy such as grid company rebates will also influence EV users' participation in V2G.

One challenge in modelling smart car park system with multiple EVs is that the EVs have different characteristics such as batteries, the SOC requirement, the users driving patterns, etc. The impacts of these factors need to be further discussed under the proposed framework in the future work.

TABLE A1
EV USAGE PROBABILITIES

	number	probabilities
Drive outside	30	0.21
Stay inside car park	114	0.79

TABLE A2
PROBABILITIES FOR DIFFERENT DRIVING DISTANCES

Driving distance	number	probabilities
Drive about 1 mile	68	0.47
Drive about 2 miles	33	0.23
Drive about 3 miles	19	0.13
Drive about 4 miles	17	0.12
Drive about 5 miles	7	0.05

APPENDIX - SURVEY DATA PROBABILITIES CALCULATION

A survey was taken to collect data from 144 EV users working in an office building from 9am to 5pm. The online survey service provides data between the period of December 2016 to January 2017. All EV users responded the survey through online submission. The average results from 144 answers are listed in the appendix.

Table A1 shows the probability of EV driving out of car park. Table A2 shows the probabilities for different driving distances. The probabilities for different driving time periods are listed in Table A3, and the probabilities for driving out time points are listed in Table A4. According to the probabilities from the survey, the probabilities for different travelling distance can be calculated and shown in Table A5.

REFERENCES

- [1] X. Hu, N. Murgovski, L. Johannesson, and B. Egardt, "Energy efficiency analysis of a series plug-in hybrid electric bus with different energy management strategies and battery sizes," *Applied Energy*, vol. 111, no. 11, pp. 1001–1009, 2013.
- [2] M. Rahmani-Andebili and G. K. Venayagamoorthy, "Smartpark placement and operation for improving system reliability and market participation," *Electric Power Systems Research*, vol. 123, no. 6, pp. 21–30, 2015.
- [3] B. K. Sovacool and R. F. Hirsh, "Beyond batteries: An examination of the benefits and barriers to plug-in hybrid

TABLE A3
PROBABILITIES FOR EV DRIVING TIME TAKEN

Time taken	number	probabilities
Drive less than 30 minutes	31	0.212
Drive about 1 hours	84	0.58
Drive about 2 hours	29	0.20

TABLE A4
PROBABILITIES FOR EV LEAVING CAR PARK TIME

EV leaving time	number	probabilities
Drive out at 10.am	11	0.08
Drive out at 11.am	24	0.17
Drive out at 12.am	41	0.28
Drive out at 1.pm	42	0.29
Drive out at 2.pm	14	0.10
Drive out at 3.pm	12	0.08

TABLE A5
TRAVELLING DISTANCE WITH DIFFERENT PROBABILITIES

Distance	Probabilities	$\bar{p}_j d_j$ (miles)
Drive about 1 miles	0.47	0.47
Drive about 2 miles	0.23	0.46
Drive about 3 miles	0.13	0.39
Drive about 4 miles	0.12	0.48
Drive about 5 miles	0.05	0.25

electric vehicles (PHEVs) and a vehicle-to-grid (V2G) transition," *Energy Policy*, vol. 37, no. 3, pp. 1095–1103, 2009.

- [4] C. Hutson, G. K. Venayagamoorthy, and K. A. Corzine, "Intelligent scheduling of hybrid and electric vehicle storage capacity in a parking lot for profit maximization in grid power transactions," in *IEEE Energy 2030 Conference*. IEEE, 2008, pp. 1–8.
- [5] P. Mitra, G. K. Venayagamoorthy, and K. A. Corzine, "Smartpark as a virtual statcom," *IEEE Transactions on Smart Grid*, vol. 2, no. 3, pp. 445–455, 2011.
- [6] G. K. Venayagamoorthy and P. Mitra, "Smartpark shock absorbers for wind farms," *IEEE Transactions on Energy Conversion*, vol. 26, no. 3, pp. 990–992, 2011.
- [7] E. Larsen, D. K. Chandrashekhara, and J. Ostergard, "Electric vehicles for improved operation of power systems with high wind power penetration," in *IEEE 2008 Energy 2030 Conference*. IEEE, 2008, pp. 1–6.
- [8] W. Kempton and J. Tomić, "Vehicle-to-grid power implementation: From stabilizing the grid to supporting large-scale renewable energy," *Journal of Power Sources*, vol. 144, no. 1, pp. 280–294, 2005.
- [9] K. Qian, C. Zhou, M. Allan, and Y. Yuan, "Modeling of load demand due to EV battery charging in distribution systems," *IEEE Transactions on Power Systems*, vol. 26, no. 2, pp. 802–810, 2011.
- [10] H. Lund and W. Kempton, "Integration of renewable energy into the transport and electricity sectors through V2G," *Energy Policy*, vol. 36, no. 9, pp. 3578–3587, 2008.
- [11] A. Y. Saber and G. K. Venayagamoorthy, "Intelligent unit commitment with vehicle-to-grid—a cost-emission optimization," *Journal of Power Sources*, vol. 195, no. 3, pp. 898–911, 2010.
- [12] C. Guille and G. Gross, "A conceptual framework for the vehicle-to-grid (V2G) implementation," *Energy Policy*, vol. 37, no. 11, pp. 4379–4390, 2009.
- [13] A. S. Masoum, S. Deilami, P. Moses, M. Masoum, and A. Abu-Siada, "Smart load management of plug-in electric vehicles in distribution and residential networks with charging stations for peak shaving and loss minimisation considering voltage regulation," *IET Generation, Transmission & Distribution*, vol. 5, no. 8, pp. 877–888, 2011.
- [14] W. Kempton, "Vehicle to grid power," in *IEEE Conference FERC*, 2007.
- [15] S. Deilami, A. S. Masoum, P. S. Moses, and M. A. Masoum, "Real-time coordination of plug-in electric vehicle charging in smart grids to minimize power losses and

- improve voltage profile,” *IEEE Transactions on Smart Grid*, vol. 2, no. 3, pp. 456–467, 2011.
- [16] C. Battistelli, L. Baringo, and A. Conejo, “Optimal energy management of small electric energy systems including V2G facilities and renewable energy sources,” *Electric Power Systems Research*, vol. 92, no. 11, pp. 50–59, 2012.
- [17] F. Soares, P. R. Almeida, and J. P. Lopes, “Quasi-real-time management of electric vehicles charging,” *Electric Power Systems Research*, vol. 108, no. 3, pp. 293–303, 2014.
- [18] K. Clement-Nyns, E. Haesen, and J. Driesen, “The impact of vehicle-to-grid on the distribution grid,” *Electric Power Systems Research*, vol. 81, no. 1, pp. 185–192, 2011.
- [19] D. Oliveira, A. Z. de Souza, and L. Delboni, “Optimal plug-in hybrid electric vehicles recharge in distribution power systems,” *Electric Power Systems Research*, vol. 98, pp. 77–85, 2013.
- [20] S. Han, S. Han, and K. Sezaki, “Development of an optimal vehicle-to-grid aggregator for frequency regulation,” *IEEE Transactions on Smart Grid*, vol. 1, no. 1, pp. 65–72, 2010.
- [21] M. Rahmani-andebili, “Spinning reserve supply with presence of electric vehicles aggregator considering compromise between cost and reliability,” *IET Generation, Transmission & Distribution*, vol. 7, no. 12, pp. 1442–1452, 2013.
- [22] M. J. Mirzaei, A. Kazemi, and O. Homaei, “A probabilistic approach to determine optimal capacity and location of electric vehicles parking lots in distribution networks,” *IEEE Transactions on Industrial Informatics*, vol. 12, no. 5, pp. 1963–1972, 2015.
- [23] L. Noel and R. McCormack, “A cost benefit analysis of a V2G-capable electric school bus compared to a traditional diesel school bus,” *Applied Energy*, vol. 126, no. 8, pp. 246–255, 2014.
- [24] Y. Ma, T. Houghton, A. Cruden, and D. Infield, “Modeling the benefits of vehicle-to-grid technology to a power system,” *IEEE Transactions on Power Systems*, vol. 27, no. 2, pp. 1012–1020, 2012.
- [25] C. Liu, K. Chau, D. Wu, and S. Gao, “Opportunities and challenges of vehicle-to-home, vehicle-to-vehicle, and vehicle-to-grid technologies,” *Proceedings of the IEEE*, vol. 101, no. 11, pp. 2409–2427, 2013.
- [26] J. Lin, K.-C. Leung, and V. O. Li, “Optimal scheduling with vehicle-to-grid regulation service,” *IEEE Internet of Things Journal*, vol. 1, no. 6, pp. 556–569, 2014.
- [27] M. Yilmaz and P. T. Krein, “Review of the impact of vehicle-to-grid technologies on distribution systems and utility interfaces,” *IEEE Transactions on Power Electronics*, vol. 28, no. 12, pp. 5673–5689, 2013.
- [28] N. Omar, M. Daowd, P. v. d. Bossche, O. Hegazy, J. Smekens, T. Coosemans, and J. v. Mierlo, “Rechargeable energy storage systems for plug-in hybrid electric vehicles—assessment of electrical characteristics,” *Energies*, vol. 5, no. 8, pp. 2952–2988, 2012.
- [29] S. M. Lukic, J. Cao, R. C. Bansal, F. Rodriguez, and A. Emadi, “Energy storage systems for automotive applications,” *IEEE Transactions on Industrial Electronics*, vol. 55, no. 6, pp. 2258–2267, 2008.
- [30] D. D. Patel, F. P. Tredeau, and Z. M. Salameh, “Temperature effects on fast charging large format prismatic lithium iron phosphate cells,” in *Vehicle Power and Propulsion Conference (VPPC), 2010 IEEE*. IEEE, 2010, pp. 1–4.
- [31] K. Amine, C. Chen, J. Liu, M. Hammond, A. Jansen, D. Dees, I. Bloom, D. Vissers, and G. Henriksen, “Factors responsible for impedance rise in high power lithium ion batteries,” *Journal of Power Sources*, vol. 97, pp. 684–687, 2001.
- [32] R. B. Wright, C. G. Motloch, J. R. Belt, J. P. Christophersen, C. D. Ho, R. A. Richardson, I. Bloom, S. Jones, V. S. Battaglia, G. Henriksen *et al.*, “Calendar-and cycle-life studies of advanced technology development program generation 1 lithium-ion batteries,” *Journal of Power Sources*, vol. 110, no. 2, pp. 445–470, 2002.
- [33] J. Wang, P. Liu, J. Hicks-Garner, E. Sherman, S. Soukiazian, M. Verbrugge, H. Tataria, J. Musser, and P. Finamore, “Cycle-life model for graphite-LiFePO₄ cells,” *Journal of Power Sources*, vol. 196, no. 8, pp. 3942–3948, 2011.
- [34] M. Ecker, J. Gerschler, J. Vogel, S. Käbitz, F. Hust, P. Dechent, and D. Sauer, “Analyzing calendar aging data towards a lifetime prediction model for lithium-ion batteries,” in *Proceedings EVS*, vol. 26, 2012, pp. 1–12.
- [35] M. Kassem, J. Bernard, R. Revel, S. Pelissier, F. Duclaud, and C. Delacourt, “Calendar aging of a graphite/lifepo 4 cell,” *Journal of Power Sources*, vol. 208, pp. 296–305, 2012.
- [36] K. Amine, J. Liu, and I. Belharouak, “High-temperature storage and cycling of C-LiFePO₄/graphite li-ion cells,” *Electrochemistry Communications*, vol. 7, no. 7, pp. 669–673, 2005.
- [37] N. Omar, M. Daowd, P. v. d. Bossche, O. Hegazy, J. Smekens, T. Coosemans, and J. v. Mierlo, “Rechargeable energy storage systems for plug-in hybrid electric vehicles—assessment of electrical characteristics,” *Energies*, vol. 5, no. 8, pp. 2952–2988, 2012.
- [38] C. Zhou, K. Qian, M. Allan, and W. Zhou, “Modeling of the cost of EV battery wear due to V2G application in power systems,” *IEEE Transactions on Energy Conversion*, vol. 26, no. 4, pp. 1041–1050, 2011.
- [39] A. Chelladurai, L. Sinkaram, V. S. Asirvadam, N. B. M. Nor, and M. Begam, “Battery characteristics due to various discharging current and temperatures: A simulation approach,” in *Research and Development (SCORED), 2012 IEEE Student Conference on*. IEEE, 2012, pp. 22–27.
- [40] S. B. Peterson, J. Whitacre, and J. Apt, “The economics of using plug-in hybrid electric vehicle battery packs for grid storage,” *Journal of Power Sources*, vol. 195, no. 8, pp. 2377–2384, 2010.