

Spring 2019

EKG AND EMG SENSORIMOTOR MEASUREMENTS TO ASSESS PROPRIOCEPTION FOLLOWING ACL RECONSTRUCTION

Teagan Frances Northrup
University of New Hampshire, Durham

Follow this and additional works at: <https://scholars.unh.edu/thesis>

Recommended Citation

Northrup, Teagan Frances, "EKG AND EMG SENSORIMOTOR MEASUREMENTS TO ASSESS PROPRIOCEPTION FOLLOWING ACL RECONSTRUCTION" (2019). *Master's Theses and Capstones*. 1280.
<https://scholars.unh.edu/thesis/1280>

This Thesis is brought to you for free and open access by the Student Scholarship at University of New Hampshire Scholars' Repository. It has been accepted for inclusion in Master's Theses and Capstones by an authorized administrator of University of New Hampshire Scholars' Repository. For more information, please contact nicole.hentz@unh.edu.

EEG AND EMG SENSORIMOTOR MEASUREMENTS TO ASSESS PROPRIOCEPTION
FOLLOWING ACL RECONSTRUCTION

BY

TEAGAN FRANCES NORTHRUP

Bachelor of Science in Electrical Engineering, University of New Hampshire, 2018

THESIS

Submitted to the University of New Hampshire

In Partial Fulfillment of

The Requirements for the Degree of

Master of Science

in

Electrical Engineering

May 2019

This thesis was examined and approved in partial fulfillment of the requirements for the degree of Master of Science in Electrical Engineering by:

Thesis Director, John R. LaCourse, Ph.D.
Professor of Electrical and Computer Engineering

Wayne J. Smith II, Ph.D.
Senior Lecturer of Electrical and Computer Engineering

Ronald V. Croce, Ph.D.
Professor of Kinesiology

On [Date of Defense]

Approval signatures are on file with the University of New Hampshire Graduate School.

TABLE OF CONTENTS

LIST OF TABLES	v
LIST OF FIGURES	vi
ABSTRACT	ix
INTRODUCTION	1
1. BACKGROUND	5
1.1. Fundamental Knee Anatomy.....	5
1.2. ACL Injuries.....	6
1.3. Proprioception and the ACL	7
1.4. Existing Techniques to Measure Proprioception	10
1.5. Prior research involving EEG and EMG in ACL reconstruction subjects	12
2. METHODS	14
2.1. Participants.....	14
2.2. Equipment	14
2.2.a. Platform Perturbator	14
2.2.b. Electroencephalogram (EEG).....	16
2.2.c. Electromyogram (EMG)	18
2.3. Measures.....	20
2.4. Procedure.....	23
2.5. Analysis	28
3. RESULTS	33

3.1 ACL group vs Healthy group	34
3.1.a. Reflex Response	34
3.1.b. Cognitive Reflex Response	37
3.1.c. Efferent Signals from the Motor Cortex	40
3.1.d. Afferent Signals to the Motor Cortex	41
3.1.e. Cognitive Processing Time	43
3.2 ACL leg vs Healthy leg within ACL participant.....	45
3.2.a. Reflex Response within ACL Participants	45
3.2.b. Cognitive Reflex Response within ACL Participants	48
3.2.c. Efferent signals from the Motor Cortex.....	52
3.2.d. Afferent Signals to the Motor Cortex	54
3.2.e. Cognitive Processing Time	55
4. DISCUSSION.....	57
LIST OF REFERENCES	60
APPENDICES	63
A – Screening Tests.....	63
B – Consent Form	69
C – Recruitment Flyer	73
D – IRB Approval	74
E – Average Cz electrode and CSD Maps	76

LIST OF TABLES

Table 1 Reflex Response of Individuals matched by BMI and leg dominance.....	35
Table 2 Cognitive Reflex Response of Individuals matched by BMI and leg dominance	37
Table 3 Efferent Signal Time from Motor Cortex of Individuals matched by BMI and leg dominance	40
Table 4 Afferent Signal Time to Motor Cortex	42
Table 5 Cognitive Processing Time in Motor Cortex of Individuals.....	43
Table 6 Reflex Response of ACL Participants	45
Table 7 Cognitive Reflex Response of ACL Participants	48
Table 8 Efferent Signals from the Motor Cortex for ACL Participants	52
Table 9 Mean Afferent Signal Time to Motor Cortex of ACL Group.....	54
Table 10 Mean Cognitive Processing Time in Motor Cortex of ACL Group	55

LIST OF FIGURES

Figure 1 Structure of ACL connecting Femur and Tibia	1
Figure 2 Ligaments and Bones of the Knee	6
Figure 3 Typical Joint Position Sense Test Set-up	11
Figure 4 Event Related Potential	13
Figure 5 Platform Perturbator	15
Figure 6 H-Bridge Switch Circuit.....	16
Figure 7 Layout of 64 Channel EEG Cap.....	17
Figure 8 Areas of the Brain.....	17
Figure 9 Pre-Amplifier EEG electrode	18
Figure 10 Four muscles used for EMG signals and the respective electrode locations.....	19
Figure 11 Spinal Reflex Response vs Cortical Response	21
Figure 12 Block Diagram of Test Set-up.....	22
Figure 13 64 Channel EEG cap	24
Figure 14 Platform Perturbator Stance	25
Figure 15 Filtered EEG and EMG Signals	28
Figure 16 EEG signals averaged over all trials.....	29
Figure 17 Averaged EEG at Cz along with CSD maps to show cortical activity.....	30
Figure 18 Initial and Secondary muscle contractions.....	31
Figure 19 Timing of Each Response with EEG and EMG data	32
Figure 20 Mean Reflex Response Time for ACL Group compared to Healthy Controls	36
Figure 21 Difference between Peak and Onset Reflex Response Time for ACL Group compared to Healthy Controls.....	37

Figure 22 Mean Cognitive Reflex Response comparing ACL Group to Healthy Control Group	38
Figure 23 Difference between Peak and Onset Cognitive Reflex Response Time for ACL Group compared to Healthy Controls	39
Figure 24 Difference between Cognitive and Reflex Response for ACL group and Healthy Group	40
Figure 25 Aggregate Mean Efferent Signals from Motor Cortex for ACL Group and Healthy Controls.....	41
Figure 26 Mean Afferent Signal Time to Motor Cortex.....	42
Figure 27 Mean Cognitive Processing Time in the Motor Cortex.....	44
Figure 28 Mean Reflex Response Times within ACL Participants	46
Figure 29 Difference between Peak and Onset Reflex Response Times within ACL Participants	47
Figure 30 Reflex Response Differences within ACL Participants	48
Figure 31 Aggregate Mean Cognitive Reflex Response for ACL Participants	49
Figure 32 Difference between Peak and Onset Cognitive Reflex Response Times within ACL Participants.....	50
Figure 33 Difference between Cognitive and Reflex Response for ACL Leg and Healthy Leg..	51
Figure 34 Cognitive Reflex Response Differences within ACL Participants.....	52
Figure 35 Aggregate Efferent Signal Time from the Motor Cortex for ACL Participants.....	53
Figure 36 Efferent Signal Time Difference between Healthy and ACL Reconstructed legs	54
Figure 37 Mean Afferent Signal Time to Motor Cortex.....	55
Figure 38 Mean Cognitive Processing Time in Motor Cortex of ACL Group	56
Figure 39 Subject 1	76

Figure 40 Subject 2	76
Figure 41 Subject 6	77
Figure 42 Subject 7	77
Figure 43 Subject 8	78
Figure 44 Subject 3	79
Figure 45 Subject 4	79
Figure 46 Subject 5	80
Figure 47 Subject 9	80
Figure 48 Subject 10	81
Figure 49 Subject 3	81
Figure 50 Subject 4	82
Figure 51 Subject 5	82
Figure 52 Subject 9	83
Figure 53 Subject 10	83

ABSTRACT

EEG AND EMG SENSORIMOTOR MEASUREMENTS TO ASSESS PROPRIOCEPTION FOLLOWING ACL RECONSTRUCTION

By

Teagan Frances Northrup

University of New Hampshire

The Anterior Cruciate Ligament (ACL) is the primary source of rotational stability in the knee. When the ACL is torn, it typically must be repaired through reconstructive surgery, however, surgery may result in proprioceptive deficiencies in the knee. Proprioception plays an important role in spatial awareness, sensing movement and reacting accordingly. Existing methods of measuring proprioception are limited because they rely only on the error between the knee angles, a single biomechanical parameter, and neglects timing of neural communication. This study examines an alternative method of measuring proprioceptive responses to a stimulus (motion) by using electromyogram (EMG) and electroencephalogram (EEG) signals to observe muscle and cortical brain activity. Data was analyzed to detect event-related-potentials in the EEG data associated with the platform perturbation stimulus along with the response time of muscle contraction to regain balance. This study compares proprioceptive measurements between 5 participants who have had an ACL reconstruction within the past 8 to 18 months and 5 participants without knee injuries. This measurement strategy has the potential to help physicians and physical therapists determine when a person can return to normal or strenuous activity as well as provide insight into whether uninjured patients have a proprioceptive deficit which may indicate an increased risk of injury.

INTRODUCTION

The Anterior Cruciate Ligament (ACL) is the primary source of anterior, posterior, and rotational stability in the knee; its role is to prevent the tibia from sliding in front of the femur which provides rotational stability [1] shown in Figure 1[2]. When the ACL is torn, it must be repaired through reconstructive surgery.

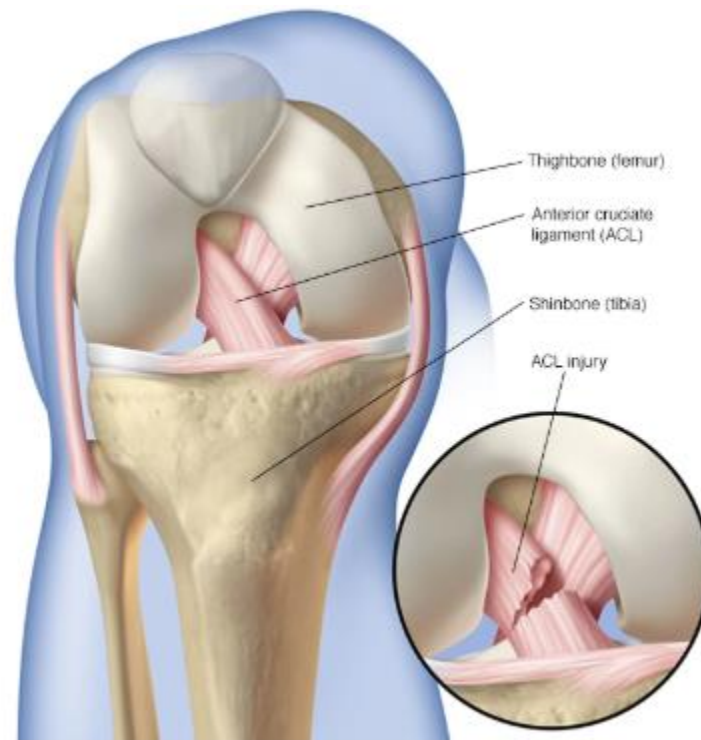

Figure 1 Structure of ACL connecting Femur and Tibia

Studies have shown that an ACL injury is more than just a simple mechanical impairment [3]. After an ACL reconstruction it has been widely documented that patients suffer from proprioceptive deficiencies in the knee. Proprioception is defined as “the specialized variation of the sensory modality of touch that encompasses the sensation of joint movement and joint position” [4]. Essentially, proprioception is very important in helping an individual understand where their knee

is in space and sensing movement. For example, when an individual senses a change in their balance there is a communication exchange between muscles and the peripheral and central nervous system. The sensory receptors in the knee send signals through the spine to the brain, indicating that there has been motion. The immediate involuntary response instructs the muscles to return the knee to its original position of stability. A secondary response incorporates the motor cortex of the brain to interpret the sensation and involuntary response, then instructs the muscles on how to respond with further precision. This two-step proprioceptive process allows individuals to adjust to changing situations and maintain balance while standing, walking or running. Therefore, effective proprioception is an important indicator of recovery for an individual with an ACL reconstruction. While there is a third step in the triphasic muscle pattern, this study will only be looking at the first two responses.

Currently, one problem physicians and physical therapists face in working with individuals who have ACL reconstructions is that they do not have adequate tools to assess recovery progress to help determine when a person can return to normal or strenuous activity. Many factors have been suggested to impact recovery including proprioception and the surgical procedure [5]. Proprioception can affect static awareness of joint position leading to an altered gait affecting recovery. There are different recovery paths depending upon a number of variables associated with the surgical process such as graft type, co-occurring injuries, and body composition. In addition, due to the lack of effective measurement tools, there is not a clear understanding of how proprioception changes after ACL reconstruction surgery. What has been documented pertaining to proprioception and ACL reconstructions is that the surgical process disrupts important communication mechanisms in the proprioceptive process.

Seventy percent of ACL injuries are a result of non-contact movements. The risk factors for non-contact ACL injuries fall into four distinct categories: environmental, anatomic, hormonal, and biomechanical. Electroencephalogram (EEG) and electromyogram (EMG) measurements can provide insight into anatomical and biomechanical communication within the body [6]. The goal of this research is to develop an improved method to measure proprioception using EEG and EMG to observe differences in proprioception after an ACL reconstruction. This research compared the proprioception of individuals who had a recent ACL reconstruction with individuals with no knee injuries. In addition, for individuals with an ACL reconstruction, EEG and EMG data from the reconstructed knee was compared to the healthy knee.

For the purpose of this study, proprioceptive awareness and movement responses were measured using EEG and EMG. The procedure used a platform perturbator to serve as the stimulus. An individual stood on the platform perturbator and the platform was controlled to move the subject slightly forward or backward. The individual had EEG and EMG sensors to measure the individual's response each time the perturbator moved.

The EEG monitored the activity in the cortex of the brain and the EMG monitored the activity of the muscles that support the knee including the anterior tibialis, gastrocnemius, quadriceps, and gluteus maximus. The EMG allowed two different muscle responses to be observed: the muscle activation from the reflex response and muscle activation from the cognitive reflex response. Within each muscle response there is both a muscle onset time and a peak time. Muscle onset is when the muscles initially contracts, and muscle peak is the maximum magnitude of the contraction. The reflex response corresponds with the involuntary reflexive response from the spinal cord. When the platform moved the sensory cells around the knee started the communication through the central nervous system by sending a signal through the spinal cord to

the brain. There was an initial response signal that returned directly to the knee from the spine, this resulted in an EMG onset and peak contraction for the reflex response. The cognitive reflex response originated from the second signal sent back to the knee, this is the signal that continued up the spinal cord to the brain, specifically the motor cortex. The motor cortex interprets how to respond to the sensation and sends a signal back to the muscles around the knee with instructions, this muscle response resulted in another EMG onset and peak contraction corresponding with the cognitive reflex response. By comparing the timing of the EMG responses, the time it takes for the spinal response and the processing response from the brain to get back to the knee was determined. The afferent and efferent signal timing were determined respectively by the time between the platform stimulus to the maximum EEG activation at the motor cortex and the time from maximum EEG activation to muscle peak contraction corresponding to the cognitive reflex response.

Along with the EMG timing, EEG data was used to observe cortical brain activity during this process. By specifically looking at the electrodes over the sensorimotor cortex, primarily Cz (See Figures 7 and 8), it was determined when information was entering or exiting that particular cortical area. By using both EEG and EMG measurements, the timing of responses were tracked from the movement of the perturbator in relationship to the neural and muscular response. This combined approach allowed the entire proprioceptive response to be measured through signal processing and data analysis.

The hypothesis was that there would be differences in response timing related to proprioception in the following responses: reflex response, cognitive reflex response and, efferent and afferent motor cortex signals cognitive processing time (See Section 2.5 for further explanation). Differences were expected to be observed for ACL participants compared with healthy participants as well as ACL knee compared with healthy knee within ACL participants.

1. BACKGROUND

1.1. Fundamental Knee Anatomy

The knee is a complex joint that is a combination of different structures including bones, ligaments, and tendons. The main ligaments and bones of the knee are shown in Figure 2 [1]. Three bones converge in the knee including the femur (thigh bone), the tibia (shin bone), and the patella (knee cap). The four ligaments in the knee connect the bones and provide stability within the knee. There are two collateral ligaments which lie along the sides of the knee and provide side-to-side stability and two cruciate ligaments on the interior of the knee joint. The medial collateral ligament is on the inside and connects the femur to tibia; the lateral collateral ligament is on the outside of the knee and connects the femur to the fibula. The cruciate ligaments cross diagonally connecting the femur to the tibia and provide front to back stability. The anterior cruciate ligament is in front of the posterior cruciate ligament and prevents the tibia from sliding in front of the femur [1].

The primary focus of this study is the role of the ACL in proprioception, particularly after an ACL reconstruction. An ACL reconstruction increases the risk for a subsequent ACL injury due to the proprioceptive deficits in the knee. Identification of proprioceptive deficits could assist in recovery as well as preventing subsequent injury.

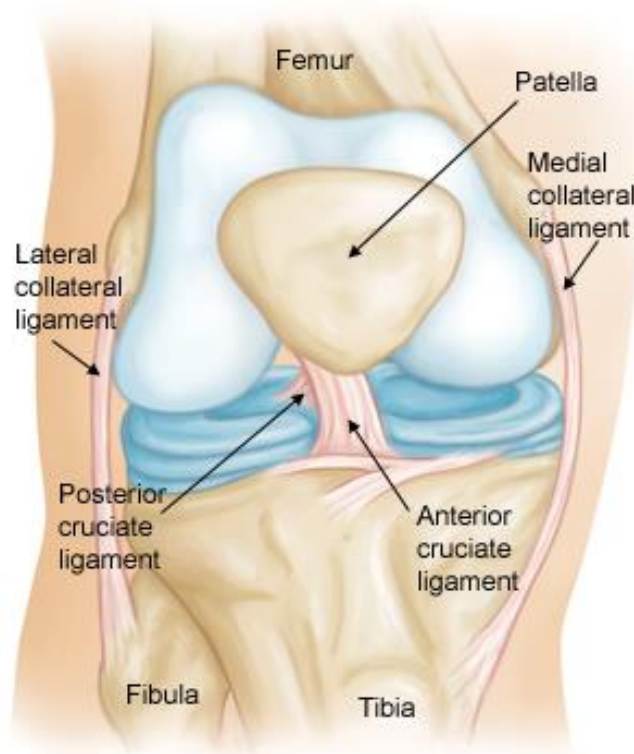

Figure 2 Ligaments and Bones of the Knee

1.2. ACL Injuries

There are two ways to obtain an ACL injury, a contact injury or a non-contact injury. Seventy percent of ACL injuries occur from non-contact injuries and commonly occur when someone is decelerating, landing, or pivoting [6]. A contact injury occurs from a direct hit to the knee. Most ACL injuries result in complete or near complete tears meaning the ACL is split into two pieces leaving the knee unstable [1]. Due to the higher number of males participating in sport related activities there are more ACL injuries in men [6]. It has been widely documented, however, that women have a significantly higher risk of ACL injuries. There has been extensive research examining a number of potential factors. According to the American Academy of Orthopedic Surgeons some of the risk factors for women include muscle strength, neuromuscular control,

pelvis to knee angles, ligaments laxity, and fluctuation of estrogen levels [6].

Irrespective of gender, partial and complete tears are repaired through surgical reconstruction. The traditional ACL reconstruction surgery consists of removing the injured ACL and replacing it with a graft which is attached to the femur and the tibia. There are two types of ACL grafts which include allografts (from a cadaver) and autografts (from the patient). Grafts are most commonly from the patella tendon or the hamstring but are occasionally harvested from the quadriceps. There is a 90% success rate for ACL reconstruction surgery related to knee stability, patient satisfaction, and return to activity [7]. While the surgery is very successful, the risk of a subsequent ACL injury on either leg increases from 1 in 3,000 (prior to injury) to 1 in 50 (after the initial injury).

1.3. Proprioception and the ACL

One of the suggested reasons for the increased risk for ACL re-injury is the proprioceptive deficits that result from ACL reconstructive surgery. Proprioception is defined as “the specialized variation of the sensory modality of touch that encompasses the sensation of joint movement and joint position” [5]. There have been many studies looking at the relationship between participants with ACL reconstructions and proprioceptive deficits. Studies have documented that ACL reconstructed knees have deficits not only in proprioception, but also in muscle strength, explosive strength, and gait [8], [9], [10], [11], [5]. One implication of proprioceptive deficits is an altered gait after surgery due to the ACL “relearning” its function. Proprioception plays a large part in the stability of the knee and knowing the position of the joint, which is critical to replicating one’s pre-injury gait.

With a goal of returning to regular activities, proprioception has been emphasized in

recovery, but other researchers have suggested that the reconstructive surgical procedure and ligament tension are important as well. However, Barrett's research suggests that an athlete's return to activity is more dependent on proprioception than the ligament tension in a clinically successful reconstruction [12]. Godinho et al. found that there are proprioceptive deficits after ACL injuries by looking at patients with complete ACL tears [11]. Lephart et al. also documented proprioceptive deficiencies in injured knees after an ACL reconstruction performed with allografts and autografts suggesting that the type of graft used in surgery does not differentially affect proprioception post-surgery [13]. Newer reconstructive techniques have considered incorporating regenerated ACLs. At this time, eighty six percent of orthopedic surgeons would consider incorporating regenerated ACL into the reconstruction if it demonstrated biological and mechanical success, but until its success matches that of the autograft method, patients and surgeons are likely to prefer the autograft [14]. While there is no specific graft that can be selected to guarantee better proprioception after surgery for every person. Each patient will have different circumstances that lead to a graft selection, each graft should have biomechanical properties like the original ACL and have rapid biological incorporation[7].

Proprioception plays a significant role in the stability of the knee and specifying the position of the joint, which is critical to replicating one's pre-injury gait. Proprioception is also necessary to detect movement and acceleration. Proprioception is part of a closed-loop activity between the knee and brain (via the central nervous system) that starts the reflex response and regulates the muscles.

Some studies have investigated neural and muscle activity to determine the reasons for proprioceptive differences in ACL reconstructed knees [8], [15], [16]. Nyland et al. states that even fully reconstructed ACL grafts never restore their native neurosensory characteristics because the

reconstructed ACL no longer transmits information in the same way it did prior to its injured state. This lack of communication may account for proprioceptive deficits that are seen after a reconstruction [15]. The ACL contains sensory receptors called mechanoreceptors that are used as a communicator within the central nervous system. The central nervous system is responsible for controlling the reflexive response and the cognitive reflex response from the motor cortex of the brain. There are three different types of mechanoreceptors in an ACL: Pacinian capsules, Ruffini nerve endings, and Golgi tendon organs. Pacinian capsules detect changes in acceleration; Ruffini nerve endings and Golgi tendon organs detect changes in joint position when the joint is under stress [6 & 7 as cited in 5]. The majority of mechanoreceptors in an ACL reside at the ends of the ligament near the femur and tibia and make up 2.5% of the ligament [3]. Adachi et al. suggests that proprioceptive function of the ACL is related to the number of mechanoreceptors [16]. They found a positive correlation between the number of mechanoreceptors and proprioception based on the accuracy of the Joint Position Sense (JPS, See Section 1.4) test. Adachi determined the number of mechanoreceptors by staining ACL remnant cross sections with “Gairns gold chloride method, as modified by Zemny et al.”, then flash frozen in liquid nitrogen. Using a light microscope, the total number of mechanoreceptors (Ruffini receptors, Pacini receptors, and Golgi tendons) were counted in each serial section. Dhillon et al. documented that intact ACLs have significant mechanoreceptors, however, reconstructed ACLs do not have similar receptors after surgery [10]. However, the mechanoreceptors may develop over time through use of the ACL or the movement of the knee through daily activities or rehabilitation. After the ACL reconstruction surgery, when the original mechanoreceptors are no longer present, the neural communication system must be reestablished with the new graft. For example, when the ACL experiences a force that displaces the tibia, a message is sent to the hamstring to contract to prevent hyperextension. Without the

mechanoreceptors the communication is compromised, and the hamstring would not contract, and the knee would not stabilize. Over time, neural communication improves but it may never recover to the pre-injury state; this differential leads to proprioceptive deficits. To thoroughly understand proprioception, this communication loop must be examined.

1.4. Existing Techniques to Measure Proprioception

Existing research documenting the deficit in proprioception after ACL reconstruction has methodological challenges pertaining to the measurement of proprioception and the comparison used in designs. Based on the existing literature, proprioception is typically measured using either the Joint Position Sense (JPS) test or the Time Threshold to Detection of Passive Motion (TTDPM) test. A 2014 publication by Relph et al. focused on ACL injuries and the effect on proprioception were only able to identify studies using JPS and TTDPM techniques to measure proprioception^[5]. JPS is defined as passively moving a joint to a specific angle and then the participant actively reproduces the same angle. The difference in position can then be measured as the error, which is the measure of a proprioceptive deficit. A typical JPS setup is shown in Figure 3 ^[21]. TTDPM is defined as a measurement of the passive movement angle before the movement can be detected by the participant ^[10], essentially how much movement is there before the participant notices the movement. TTDPM is used much less than JPS, and when it is used it is typically in conjunction with JPS.

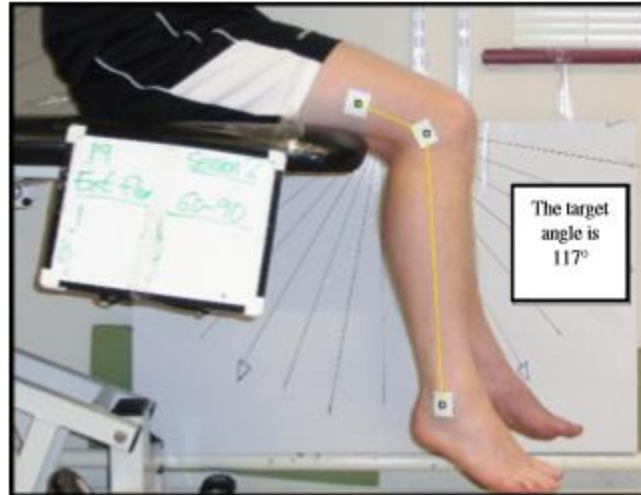

Figure 3 Typical Joint Position Sense Test Set-up

While the results of both measures quantify proprioception, they don't reflect the sense of force or movement [8]. In addition, both methods are artificial and not applicable to real world circumstances which have many more factors that influence an individual's response and reaction. JPS is also limited in the sense that it relies only on the error between the knee angles, a single biomechanical parameter, [8] and neglects timing. There are even fewer studies that use TTDPM and many of those studies also use JPS. Beyond the measurement of proprioception, few research designs have incorporated an actual stimulus to which participants must respond so test conditions tend to be artificial. The most commonly used measures of proprioception have challenges. Many designs have been based on a single assessment many months post reconstruction that compares the reconstructed knee to individual's uninjured knee raising concerns about additional factors that might influence results including type, leg dominance, severity of ACL injury, and muscle strength differences among others. So, while the research indicates ACL reconstructions have limitations with reestablishing proprioception to its pre-surgical state, the methods could be improved to gain more detailed information about the proprioceptive process and where the challenges arise so that information could be used more effectively in the recovery process.

1.5. Prior research involving EEG and EMG in ACL reconstruction subjects

Little is known about the role of the brain in proprioception. Baumeister et al. suggest EEG may provide insight into the altered brain activity after an ACL reconstruction which may improve the design of rehabilitation programs. He found a significantly higher frontal theta power in the ACL group and higher Alpha-2 power in the ACL reconstructed limb, suggesting differences in focus and attention as well as differences in sensory processing in the somatosensory cortex [17]. Baumeister et al. performed another study that uses background EEG in addition to the JPS test. Baumeister suggested that if the afferent information from the knee are altered after reconstruction surgery (proprioceptive deficits), then one can assume the cortical information processing has also changed and may be detectable [8].

In related work, Arnfred et al. examined the processing in the temporal domain from a stimulus and determined that event-related-potentials (ERPs) are very important for the investigation of cognitive processing in the somatosensory cortex [18]. ERPs signify cognitive activity in response to a stimulus, or event, which are typically quantified by onset latency and amplitude. ERPs allow the transient cortical activity of the brain to be observed and recorded. The recorded EEG data is segmented into “trials”, then the data is averaged over all the trials to get an overall view of the transient EEG activity. Specific ERPs can then be found by polarity and timing, as in Figure 4 [19]. The first ERP, N1, signifies negative polarity around 100 ms typically measured between 70 and 200 ms. N70 represents the actual time that the signal is the most negative in the time frame and where the ERP N1 actually occurs. P1 and N2 represent the polarity and what time to look for that specific ERP and the P100 and N140 show the actual time of the specific ERP.

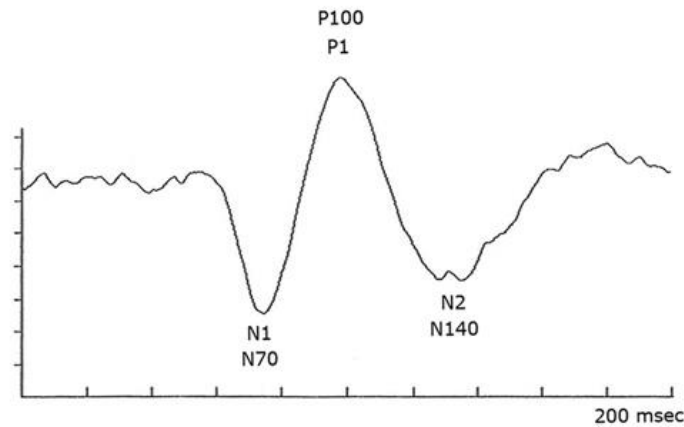

Figure 4 Event Related Potential

ERPs are sorted into two groups: early wave and cognitive. The early wave is typically within the first 100 milliseconds after a stimulus and are denoted “sensory” while the “cognitive” EPRs reflect how a person evaluates the current stimulus [20]. Differences in ERPs will be informative when comparing ACL reconstructed legs with uninjured legs.

With regard to muscular activity, Solomonow et al. reviewed studies using EMG to observe the muscle activity after an ACL reconstruction when force was exerted on the knee and observed no muscle activity in the hamstrings. They suggest that just after surgery the communication between the new graft and the muscles may not have been established [4]. By using an EMG to monitor muscle activity, it allowed researchers to observe the timing of muscle contractions and the strength of those contractions while using the Joint Position Sense (JPS) test to measure proprioception.

2. METHODS

2.1. Participants

Participants were between the ages of 18 and 30 and categorized themselves as physically active. There was a total of 10 participants (only females) in this study. Five of the participants had an ACL reconstruction within the past 8-18 months and five of the participants had no history of knee injuries. The study procedure was approved by the Institutional Review Board (IRB) and all the participants signed a consent form that laid out the testing procedure and participation expectations, as well as a questionnaire. Participants could stop at any point during the testing.

2.2. Equipment

Testing and data collection took place in the Biomechanics & Motor Control Lab in New Hampshire Hall at the University of New Hampshire. This study used BrainProducts™ EEG and EMG instrumentation (actiCHamp, actiPOWER, SplitterBox BP-04242-32, TriggerBox BP-245-1550, BIP2AUX adaptor) in the lab. In addition, a platform perturbator provided forward and backward movement as a stimulus to which participants reacted. More detailed discussion of the equipment used follows.

2.2.a. Platform Perturbator

A platform perturbator was used to offset one's balance by quickly moving the platform forward and backward on which the subject stands. There was no side to side (lateral) movement.



Figure 5 Platform Perturbator

An electric linear actuator was attached to the base and was used to shift the platform. A DC voltage supply powered the actuator while high power metal-oxide-semiconductor field-effect transistors (MOSFET, IRL520 and IRL9540) were used in an H-Bridge configuration for control. A trigger was generated by the researcher that sent a signal to the gate leads of the diagonal MOSFETs to turn them on, which then turned on the actuator. Rollers were placed below the platform and used as linear motion guides to reduce the frictional force added from the weight of the subject [22]. The platform pertubator moved one inch per second for a duration no longer than one second. As the subject regained their balance, the pertubator remained idle until it received another signal to perturbate the subject backwards. The platform pertubator was controlled using an H-bridge circuit, shown in Figure 6, which allowed the researcher to use a controller to move the platform forward and backwards.

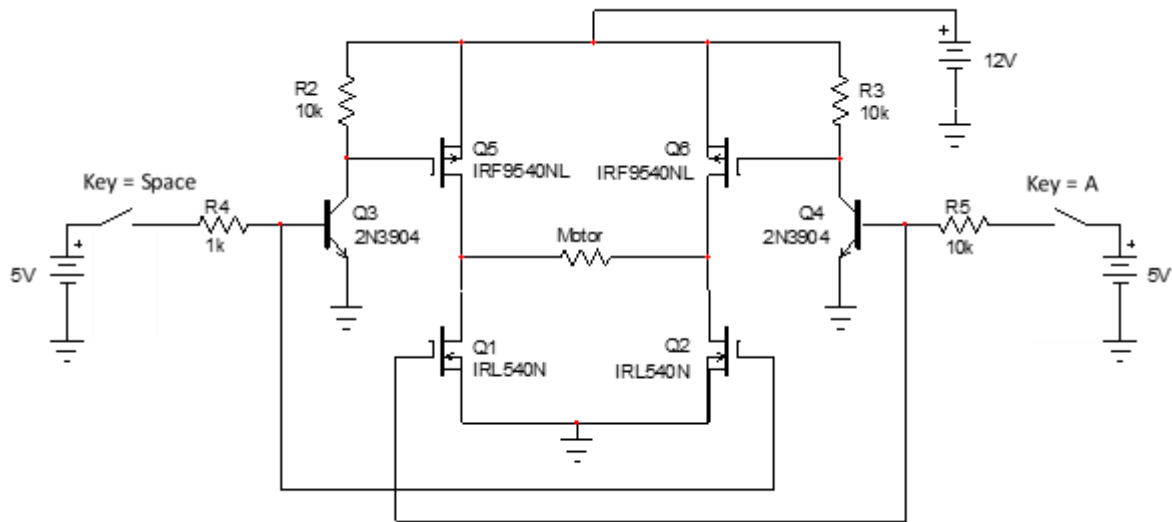

Figure 6 H-Bridge Switch Circuit

2.2.b. Electroencephalogram (EEG)

The EEG was used to measure the cortical activity of the brain using surface electrodes on the scalp. EEG is typically used in two ways, to observe background EEG or ERPs. There are 4 frequency bands that are usually measured with background EEG: delta (<4 Hz), theta (4-7 Hz), alpha (8-13 Hz), and beta (14-50 Hz). Delta frequencies are generally seen during sleep, theta frequencies are seen during disappointment, frustration, and meditation, alpha frequencies are prominent during a resting period with eyes closed, and beta frequencies are seen during intense mental activity with eyes open [23]. For this study, background EEG was not investigated. EEG signals were measured using the BrainVision™ software (BrainVision Recorder Version 1.21.0004 and BrainVision Analyzer Version 2..1.327) and a 64 channel EEG cap (see Figure 7 [24]) to extract event related potentials corresponding to the stimulus. An ERP is the measured brain response directly related to a specific sensory, cognitive, or motor event. The specific ERPs

investigated were the N100 and P300. The N100 is observed between 90-200 ms after an unexpected stimulus is presented. The P300 is observed 200-400 ms after the stimulus and is elicited in the decision-making process and a person's reaction to the stimulus [20]. For this study, the EEG was recorded with a frequency range from 0.1 to 50 Hz and a sampling rate of 1000 Hz. The EEG was recorded in a unipolar manner with reference electrode FCz and ground electrode FPz.

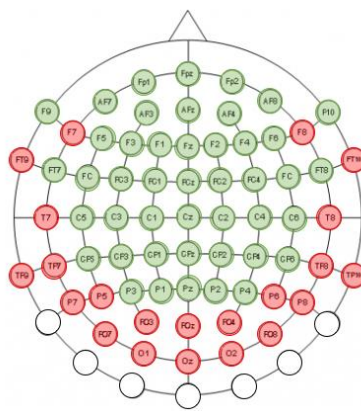

Figure 7 Layout of 64 Channel EEG Cap

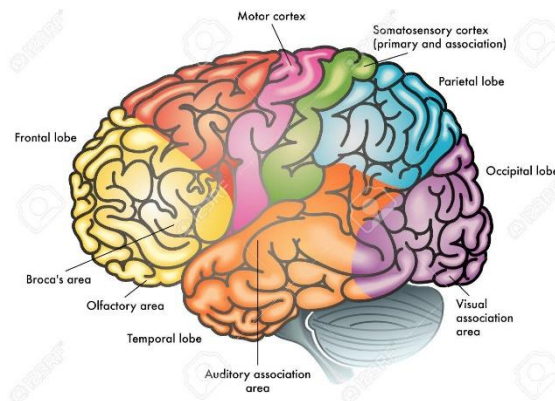

Figure 8 Areas of the Brain

The areas of the brain that were monitored included the motor cortex and the somatosensory cortex. The motor and somatosensory cortices are near the middle of the brain as

shown in Figure 8 [25]. These areas were monitored using a 64 channel EEG cap as shown in Figure 7 to look at specific ERPs. While all 64 channels were recorded, only 44 channels were used for data analysis (green in Figure 7). The remaining channels were left un-prepped and removed during analysis (red in Figure 7). The EEG cap used preamplified electrodes (See Figure 9) [26] for each channel that attached to an amplifier with the BrainVision™ system.



Figure 9 Pre-Amplifier EEG electrode

2.2.c. Electromyogram (EMG)

The EMG was used to assess the health of muscles and the motor neurons that control them. The motor neuron sends an electrical signal to the muscle resulting in muscle contraction [27]. An electromyogram uses surface or invasive electrodes to detect the summated electrical activity of muscle cells. The signals obtained from the EMG were used to determine timing of muscle reactions to the perturbator [2]. To best determine the reaction, EMG signals were obtained from four different leg muscles: rectus femoris, gluteus maximus, tibialis anterior and gastrocnemius. Figure 10 displays each of these muscles and the electrode placement. These four muscles play key roles in postural stability. These muscles allowed researchers to observe synergy patterns of the leg muscles. For this study, the EMG was recorded with a frequency range from 20 to 450 Hz and a sampling rate of 1000 Hz.

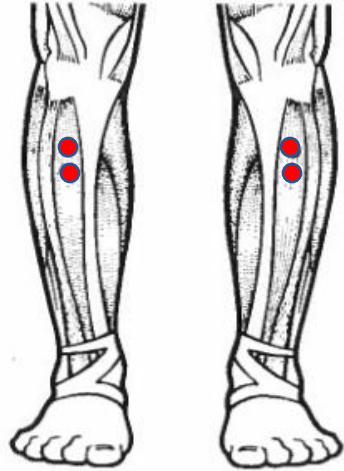

10a. Tibialis Anterior Muscle

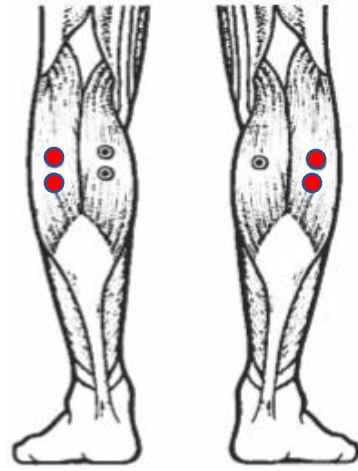

10b. Gastrocnemius Muscle

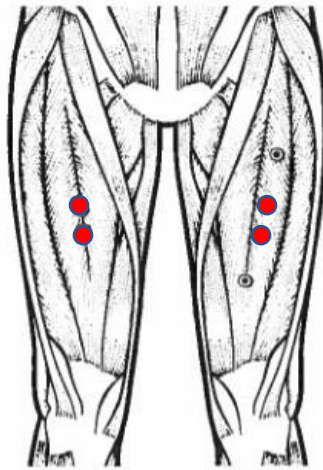

10c. Rectus Femoris Muscle

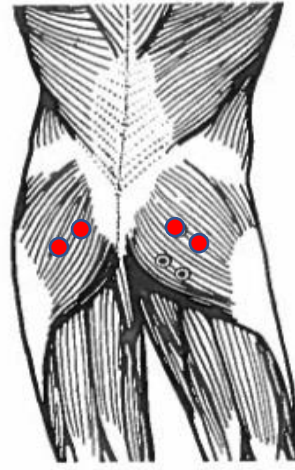

10d. Gluteus Maximus Muscle

Figure 10 Four muscles used for EMG signals and the respective electrode locations

2.3. Measures

Proprioceptive responses were measured using EEG and EMG. The procedure used a platform perturbator to serve as the stimulus. An individual stood on the platform perturbator and the platform was controlled to move slightly forward or backward. The individual had EEG and EMG sensors to measure the individual's response each time the perturbator moved.

The EEG monitored the cortical brain activity and the EMG monitored the activity of the muscles that assist in re-stabilizing the body post-perturbation. The EMG allowed two different muscle responses to be observed, the reflex response and the cognitive reflex response. Each muscle response had an onset time and peak time, the onset corresponded to the first sign of muscle activity and the peak corresponded to the maximum contraction. The reflex response is a result of the involuntary response from the spinal cord. When the platform moved, a spinal-level motor reflex response was initiated resulting in a muscle contraction of the muscles stabilizing the knee. Simultaneously, the cognitive reflex response was continues up the spinal cord to the sensorimotor cortex. The motor cortex transmitted signals through the spinal cord to the muscles around the knee to contract and re-stabilize the body, this muscle response corresponded with the cognitive reflex response. The comparison of responses is illustrated in Figure 11_[28] where the reflex response (purple) is the involuntary response from the spinal cord directly back to the knee musculature. The blue and red paths shown is the collective cortical response that originates from the knee to the brain, which then sends signals back to the muscles through the spinal cord.

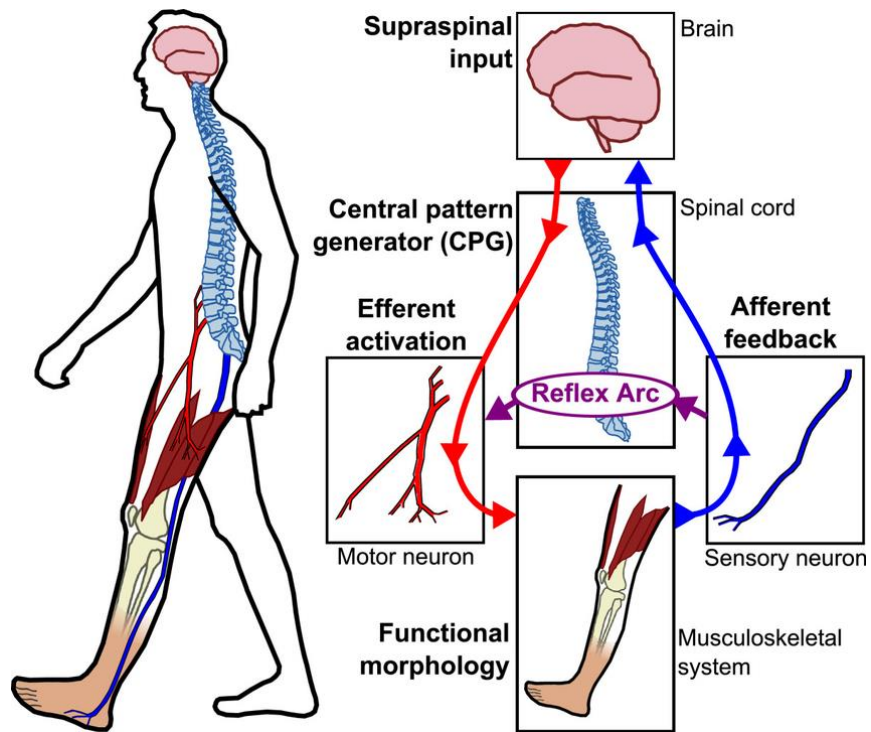

Figure 11 Spinal Reflex Response vs Cortical Response

Along with recording muscle responses from the platform perturber, EEG data was used to observe the cortical brain activity during this process. By specifically looking at the electrodes over the sensorimotor cortex it was determined when information was received by a certain area of the brain and when information was being sent out from that area. By using both EEG and EMG measurements, the timing of responses could be tracked from the movement of the perturber in relationship to the neural and muscular response. This combined approach allowed the entire proprioceptive response to be measured through signal processing and data analysis. Figure 12 shows a block diagram of the test set-up.

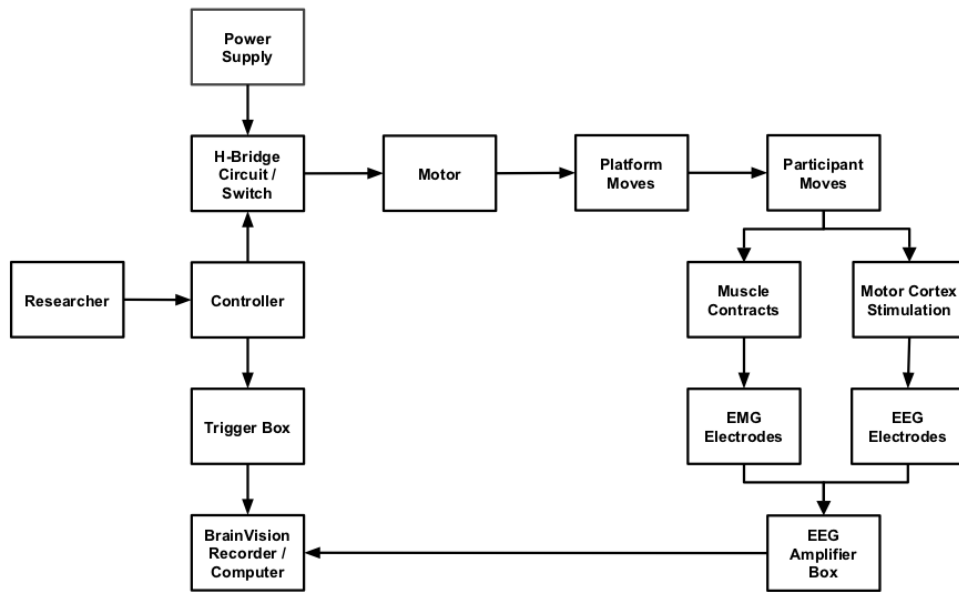

Figure 12 Block Diagram of Test Set-up

2.4. Procedure

Participants were tested at the Biomechanics & Motor Control Lab in New Hampshire Hall at a mutually convenient time. Participants were given a thorough explanation of the study and read and signed the informed consent. Participants were given a brief questionnaire asking questions about any injuries, dominant leg, demographic questions, and questions related to other risk factors for ACL injuries. A copy of the questionnaire and consent form are included in the Appendix. When participants arrived at the Biomechanics & Motor Control Lab, there was soft piano music playing until the participant stepped onto the platform to begin testing. The testing space was an environmentally comfortable room.

The EMG was used to measure the level of muscle electrical activity of the Anterior Tibialis (AT), Medial Gastrocnemius (MG), Quadriceps (Q), and Gluteus Maximus (GM). Silver/silver chloride pre-gelled surface electrodes were placed 2.5 cm apart and parallel to the muscle fibers over the longitudinal midline between the motor point and the tendon. Thorough skin preparation for electrode placement included removal of dead epithelial cells with a razor, isopropyl alcohol, and an abrasive pre-gel (Nuprep abrasive preparation gel). The skin was cleaned and abraded to reduce the skin impedance for a better signal. EMG was recorded with a frequency range from 20 to 450 Hz and a sampling rate of 1000 Hz.

For the EEG, the participants head circumference was measured to best fit a 64-channel EEG cap. An example of the 64-channel EEG cap that was used is shown in Figure 13_[26].



Figure 13 64 Channel EEG cap

Gel was applied to each electrode site with a blunt needle (which additionally slightly abrades the scalp to reduce contact impedance) until an impedance of less than $25\text{-k}\Omega$ was reached to improve the quality of the signals. EEG was recorded with a frequency range from 0.1 to 50 Hz and a sampling rate of 1000 Hz.

Each participant stood with no shoes on the platform perturbator. Earbuds were worn to drown out the motor actuator prior to the platform perturbator moving so that the participant could not anticipate the movement. To allow each leg to be individually tested, the leg tested had the foot firmly planted on the platform while only the toe of the other foot was touching to help with balance as shown in Figure 14.



Figure 14 Platform Perturbator Stance

EMG and EEG data collection was synchronized with perturbator data via auxiliary inputs into the EEG system hardware. EEG and EMG data were recorded and analyzed using the BrainVision™ Recorder and Analyzer Software.

One trial consisted of the participant being perturbed forward at a speed of one inch per second for a random duration (400 to 1000 ms), and then moved backwards once balance had been regained. Perturbation timing was randomized between 0.5 and 5 seconds to reduce the participant's anticipation of the platform movement. The platform never moved more than one inch for a single trial. Generally, participants maintained balance, but if the participant lost balance during a trial, the next trial did not progress until they had comfortably regained balance. For each participant, 100 accurate responses were taken with either two-minute standing or sitting breaks after every 25 trials to prevent muscle fatigue. The heart rate of the participants was observed at 3

times during the testing period to help determine changes in the participant heart rate: before starting the perturbation on the first leg, before starting perturbation on the second leg and after the second leg was finished.

The procedure for recording measurements:

1. Measure and record heart rate
2. Start recording on the BrainVision™ Recorder software
3. Save file for new subject with the leg being tested and the testing date
4. Participant stands on the one leg being tested with the other leg just for balance
5. Remain standing for 25 trials forwards and 25 trials backwards
6. 2 minute break so the participants legs don't get fatigued
7. 25 trials forward/25 trials backwards
8. 2 minute break
9. 25 trials forward/25 trials backwards
10. 2 minute break
11. 25 trials forward/25 trials backwards
12. Stop recording
13. Remove EMG from tested leg
14. Set up EMG electrodes on other leg
15. Reevaluate EEG impedances
16. Reapply gel to EEG electrodes if necessary
17. Measure and record heart rate
18. Start recording on the BrainVision™ Recorder software for other leg
19. Save file for new subject with the leg being tested and the testing date

20. 100 trials forward and 100 trials back with 2 minute break every 25 trials
21. Stop recording
22. Measure and record heart rate
23. Remove EEG cap
24. Remove EMG electrodes

2.5. Analysis

Data analysis was performed using BrainVision™ Analyzer on the raw data recorded from the BrainVision™ Recorder. The unused channels were removed: TP9, TP7, F7, F8, FT9, T7, P7, P5, P6, P8, PO7, PO3, POz, PO4, PO8, O1, O2, Oz, TP8, TP10, T8, and FT10 (See Figure 7). These channels were not prepped with the EEG cap; therefore, no analysis was necessary. All remaining EEG signals were bandpass filtered from 0.1 to 50 Hz and the EMG signals were filtered from 70 to 200 Hz.

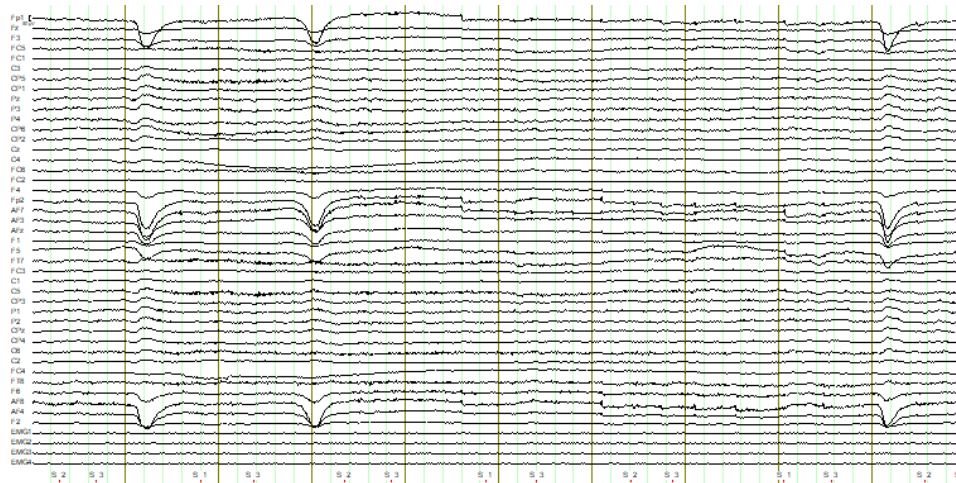

Figure 15 Filtered EEG and EMG Signals

Ocular correction used independent component analysis (ICA) to detect and remove artifacts created by blinks. The ocular correction used FP1 as the reference for eye artifacts.

The data was then segmented into 600 ms epochs, 200ms pre-stimulus to 400ms post stimulus. The platform perturbation served as the stimulus which was connected through the H-Bridge circuit to the trigger box. For each movement of the platform, a stimulus marker was recorded on the BrainVision™ recorder to be synchronized with the data. The pre-stimulus time was used for baseline correction.

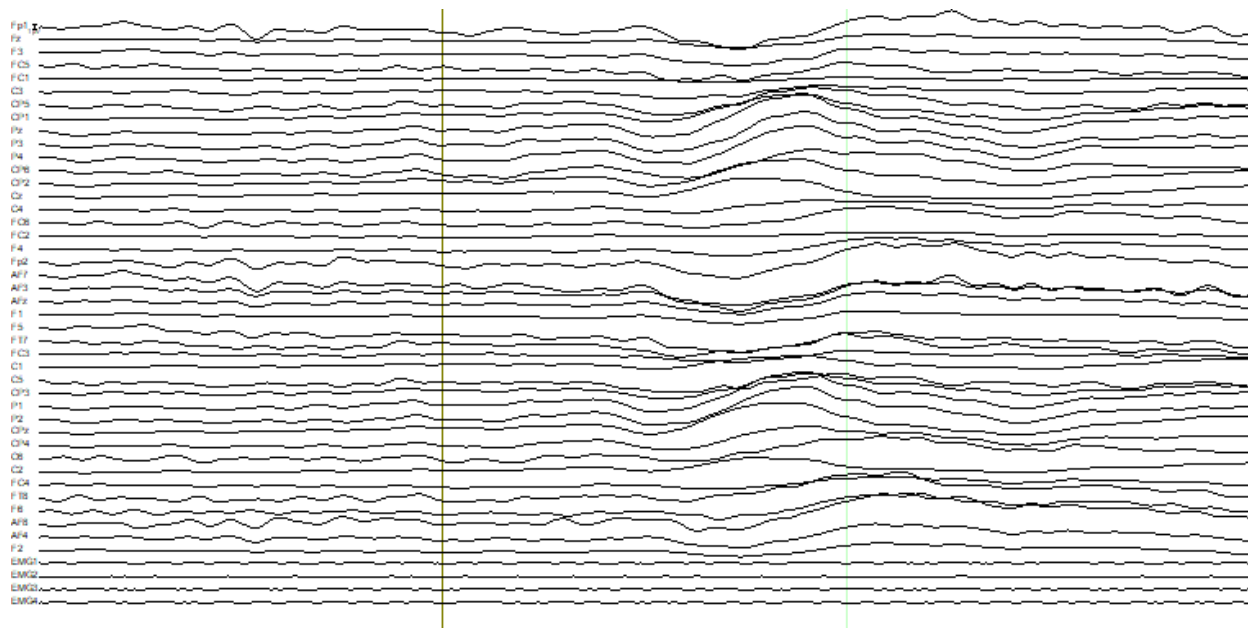

Figure 16 EEG signals averaged over all trials

Each EEG channel was then averaged over all trials, allowing for detection of ERPs. Figure 16 shows the averaged EEG data over each epoch. The averaged data had the same timing as the segmented epoch, where the beginning of the signal was at 200 ms before the stimulus and the end was 400ms after the stimulus. The stimulus marker was recorded as “time 0” which is shown by the vertical line across every channel. The BrainVision™ peak detection algorithm was used to search for the N100 and P300. The N100 is the most negative component between 90 and 200 ms post stimulus and the P300 is the most positive component between 200 and 400 ms post stimulus. The axis in Figure 17 are flipped, so positive polarity is the bottom and negative polarity is towards the top of the figure. Figure 17 also provides a typical current source density (CSD) map at 0 ms (stimulus), N100 peak time, P300 peak time, and 400 ms post stimulus.

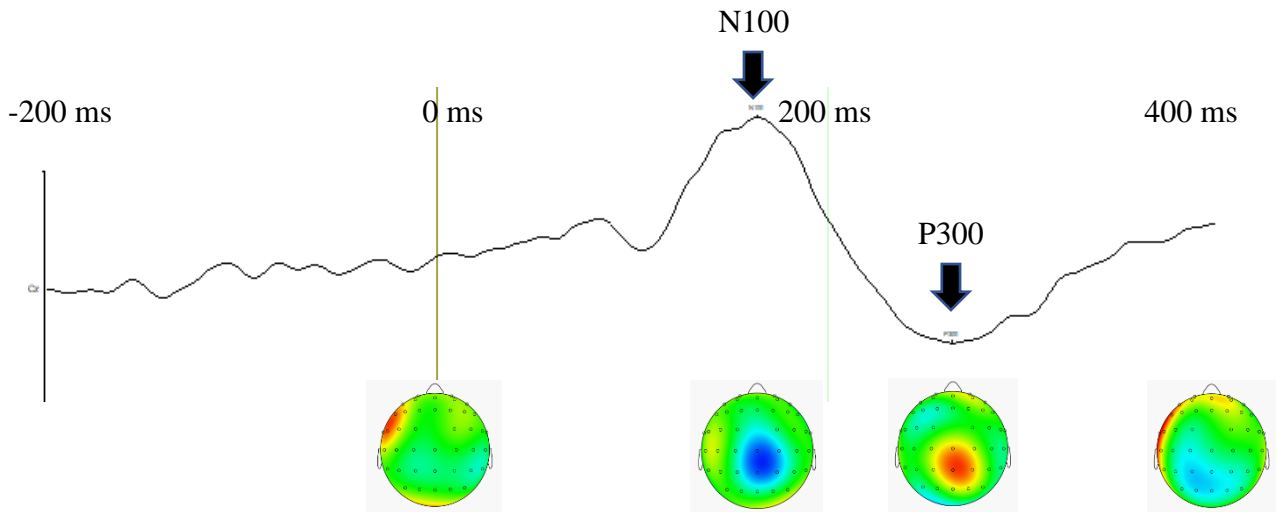

Figure 17 Averaged EEG at Cz along with CSD maps to show cortical activity

The built in CSD function performed the spatial second derivative for each electrode relative to the surrounding electrodes. This shows the areas of the brain that has the most activity along with the polarity: red denotes a positive polarity and blue denotes negative polarity. While not all electrode sites were prepped, the sites surrounding the motor cortex and somatosensory cortex were, so the CSD maps can accurately show what occurred in those areas. Averaged Cz data and CSD maps are provided for every participant in Appendix E.

Two separate EMG searches were computed to find the muscle contraction corresponding with the reflex and cognitive reflex response. The reflex response search was limited from the time of the stimulus to the time of the N100 potential, while the cognitive reflex response search was from the N100 potential to the end of the epoch (400ms). The ERP data and both EMG data sets were exported to be analyzed outside of the BrainVision™ software to determine the timing of each response. The two distinct muscle contractions are shown in Figure 18.

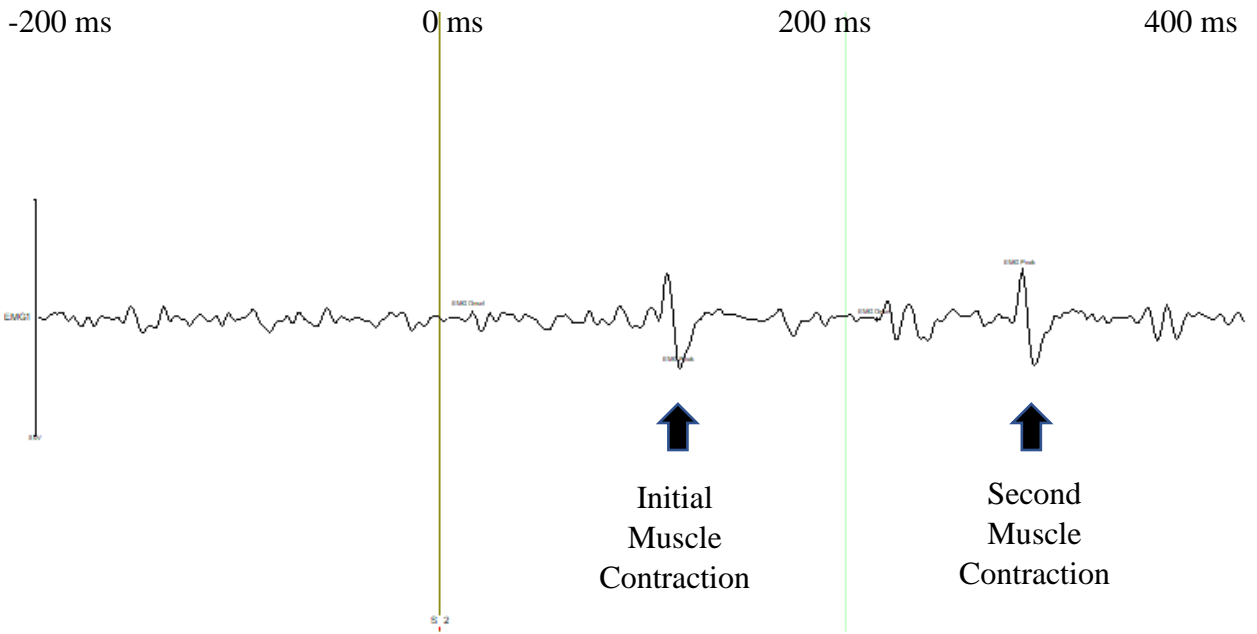

Figure 18 Initial and Secondary muscle contractions

For this study, five different processes were examined as measures of proprioception including the reflex response, cognitive processing, cognitive reflex response, afferent signal to the motor cortex, and efferent signal from the motor cortex. Each process is shown in Figure 19. The reflex response is the time from the movement of the platform perturbator (stimulus) to each muscle's initial peak contraction. The cognitive processing time is defined as the time from the N100 ERP at Cz to the P300 ERP at Cz. The cognitive reflex response is the time from the movement of the platform perturbator (stimulus) to each muscle's secondary peak contraction. The afferent signal to the motor cortex is the time from the movement of the platform to the N100 ERP at Cz and the efferent signal is from the N100 ERP at Cz to the secondary peak contraction of each muscle. The timing of all responses was calculated using the peak EMG time.

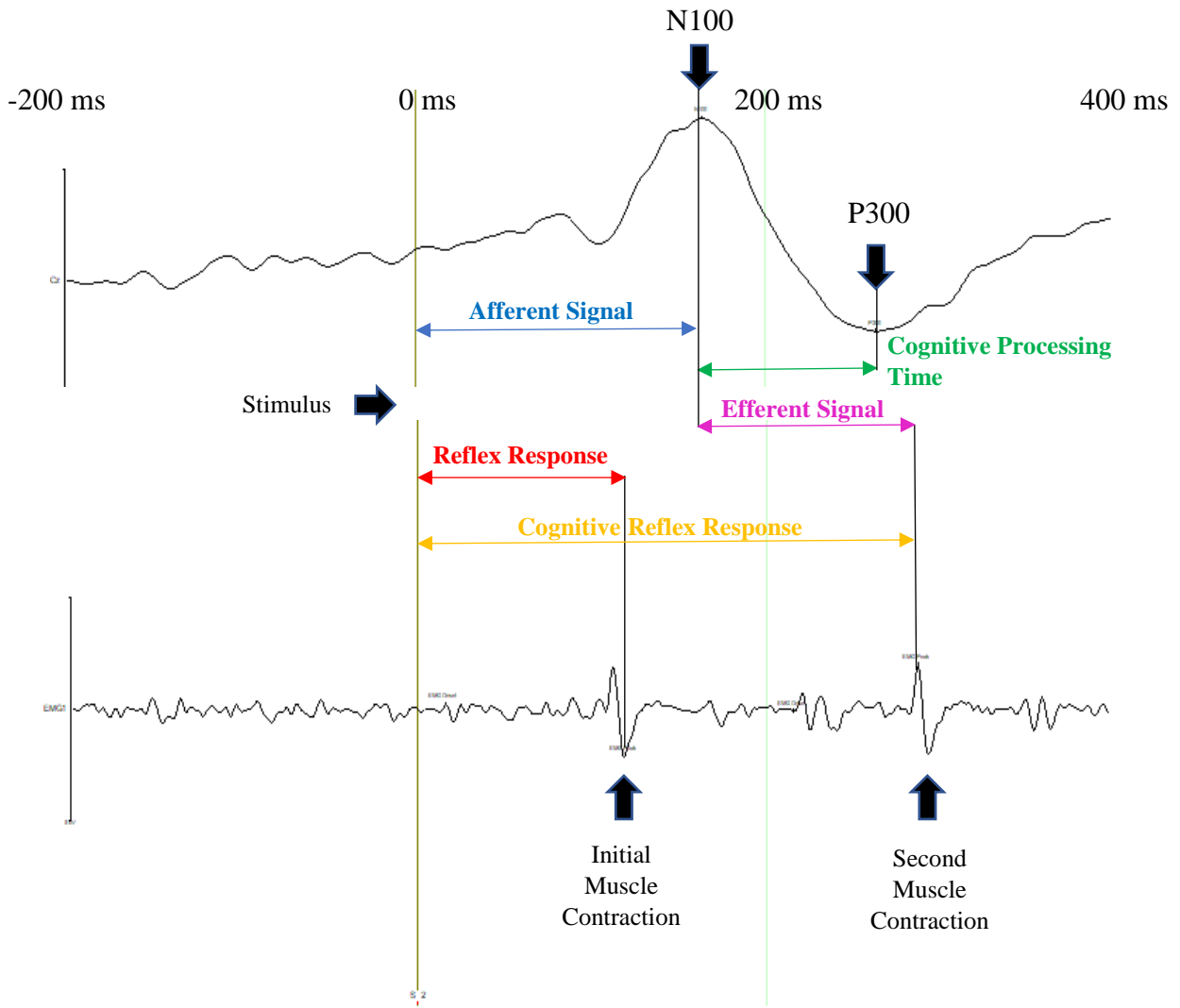

Figure 19 Timing of Each Response with EEG and EMG data

3. RESULTS

The results presented compare the muscle activity and cognitive activity as participants engaged in the proprioceptive process. Participants with an ACL reconstruction are compared to two different control conditions: one between subjects and one within subjects. In Section 3.1, the first set of comparisons examines aggregated data from the ACL reconstructed participants and aggregated data from an independent group of healthy participants. In selecting the comparison leg for the healthy controls, four of five participants were right leg dominant and had left leg with ACL reconstructions. Thus, the control group mirrored the ACL group by including four left, non-dominant legs, and one right, dominant leg used in the comparison group. In Section 3.2, the second comparison was within subjects and examined five participants' ACL reconstructed leg with their other healthy leg. Results are presented in aggregate as well as pairing the ACL leg to the healthy leg.

Results are presented with regard to the following hypotheses informed by prior research. While results are displayed and were tested using statistical procedures, given the very small sample size, statistically significant results are unlikely, but trends may indicate directions for future research.

It was hypothesized that:

- 1) Participants with ACL reconstructions will have different response timing related to proprioception than participants with healthy knees across the following measures:
 - a. Reflex response
 - b. Cognitive reflex response

- c. Efferent signals from the motor cortex
 - d. Afferent signals to the motor cortex
 - e. Cognitive processing time
- 2) Participants with ACL reconstructions will have different response timing related to proprioception in their ACL reconstructed knees as compared with their healthy knees across the following measures:
- a. Reflex response
 - b. Cognitive reflex response
 - c. Efferent signals from the motor cortex
 - d. Afferent signals to the motor cortex
 - e. Cognitive processing time

3.1 ACL group vs Healthy group

This comparison addresses whether on average there is a difference in processing time required for proprioception between individuals who had a reconstructed ACL as compared to individuals who never had a similar injury.

3.1.a. Reflex Response

The mean reflex response time (Time from the perturbation stimulus to the first peak contraction) is shown for each participant in Table 1.

Participant	Anterior Tibialis	Gastrocnemius	Quadriцеп	Gluteus Maximus
*3	52.96	53.14	na	54.86
8	53.71	51.33	54.11	58.67
*4	73.34	96.87	79.41	84.30
7	74.38	88.57	71.48	80.00
*5	73.70	70.11	72.07	66.41
1	74.23	80.62	76.75	80.99
*9	62.70	59.47	62.72	65.86
2	76.65	78.40	77.82	81.47
*10	109.15	109.12	108.29	101.30
6	59.00	85.59	78.58	73.51

*Represents ACL participant

Table 1 Reflex Response of Individuals matched by BMI and leg dominance

Aggregated Mean Reflex Response times for all participants in the ACL Group compared to the healthy control group across all four muscles is shown in Figure 20. The ACL group had a longer mean reflex time across three of the four muscles, though the differences were not statistically significant using independent samples t-tests (Anterior Tibialis: $t(8)=.640$, $p=.540$; Gastrocnemius: $t(8)=.066$, $p=.949$; Quadriцеп: $t(7)=.880$, $p=.408$; Gluteus Maximus: $t(8)=-.041$, $p=.968$)

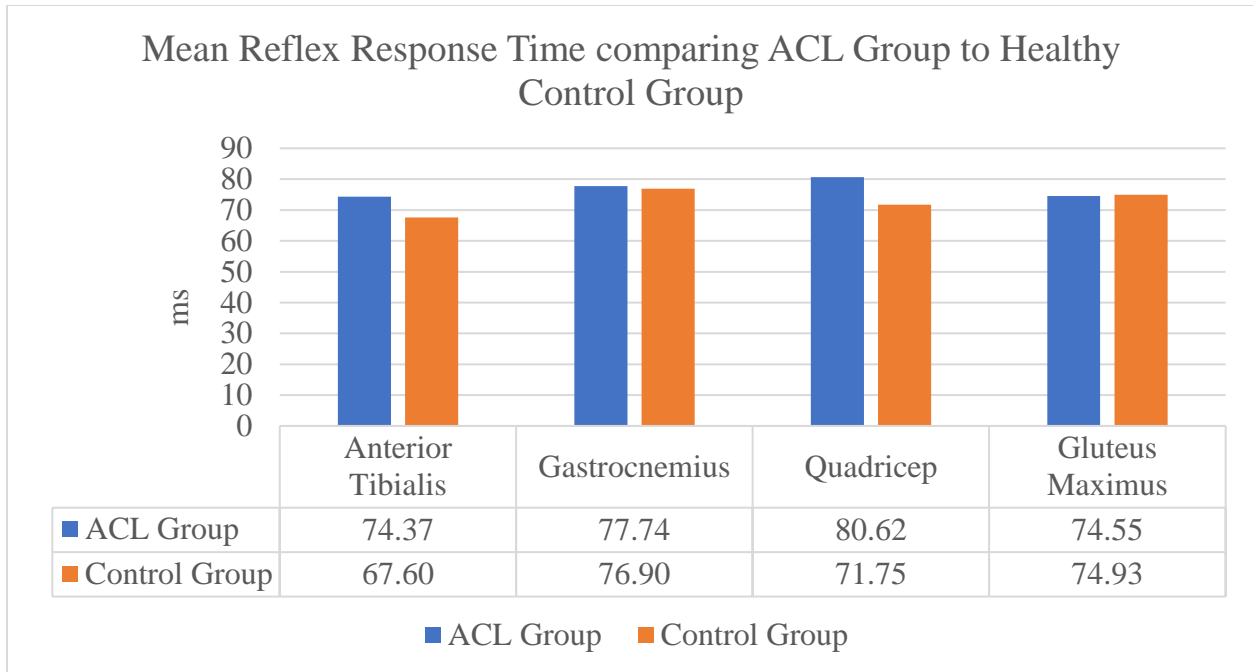

Figure 20 Mean Reflex Response Time for ACL Group compared to Healthy Controls

Independent samples t-tests were conducted to compare the difference between onset and peak in the reflex response for participants with an ACL reconstruction as compared to participants with healthy knees, shown in Figure 21. The results were not statistically significant between groups for the difference between onset and peak for the reflex response across all four muscles (Anterior Tibialis: $t(8)=.753$, $p=.473$; Gastrocnemius: $t(8)=-.218$, $p=.833$; Quadriceps: $t(7)=1.084$, $p=.314$; Gluteus Maximus: $t(8)=-.296$, $p=.795$).

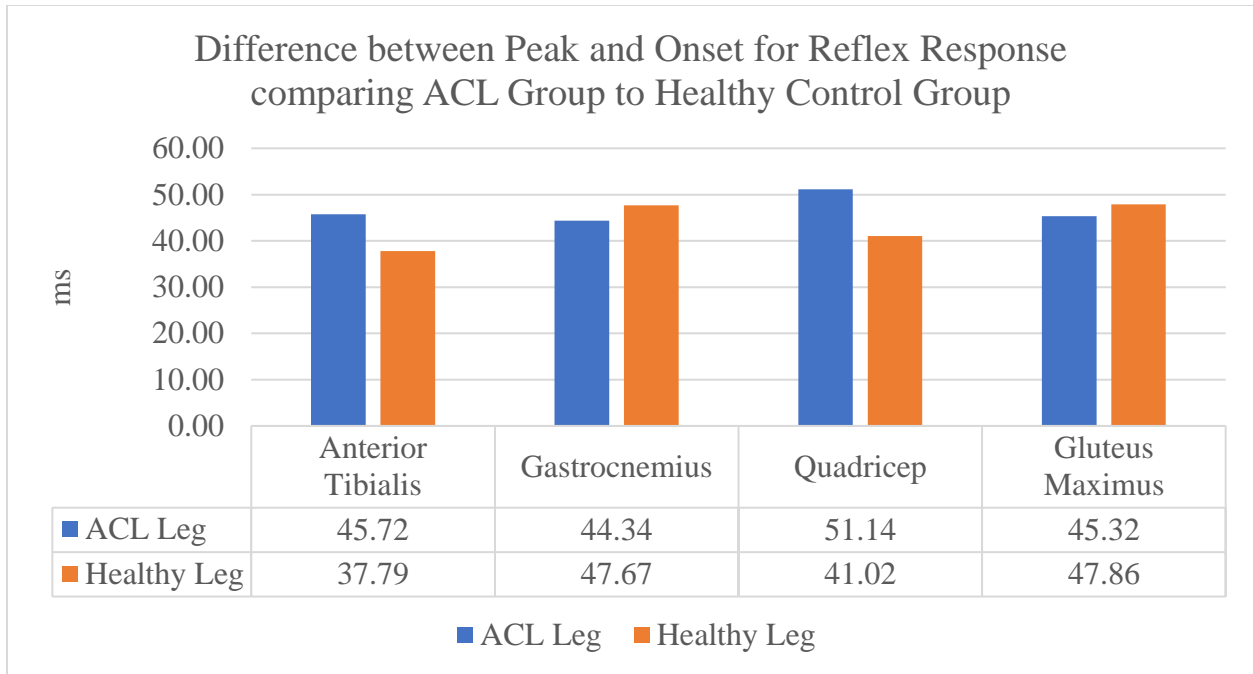

Figure 21 Difference between Peak and Onset Reflex Response Time for ACL Group compared to Healthy Controls

3.1.b. Cognitive Reflex Response

The mean cognitive reflex response time (Time from the perturbation stimulus to the second peak contraction) is shown for each participant in Table 2.

Participant	Anterior Tibialis	Gastrocnemius	Quadriceps	Gluteus Maximus
*3	249.20	245.69	na	253.25
8	238.99	215.26	248.97	237.95
*4	258.66	250.62	251.13	255.28
7	261.24	220.18	263.67	274.89
*5	227.01	187.21	246.70	247.49
1	275.39	267.17	275.67	277.89
*9	241.71	233.19	242.08	230.35
2	262.11	250.52	264.48	265.60
*10	300.88	297.24	301.41	301.38
6	176.88	193.93	204.70	213.41

*Represents ACL participant

Table 2 Cognitive Reflex Response of Individuals matched by BMI and leg dominance

Aggregated Mean Cognitive Reflex Response times for all participants in the ACL Group in comparison to the Healthy Control Group across all four muscles is shown in Figure 22. The ACL group had slightly longer mean Cognitive Reflex Response time across four muscles, though the difference was not statistically significant using independent samples t-tests (Anterior Tibialis: $t(8)=.585$, $p=.575$; Gastrocnemius: $t(8)=.610$, $p=.559$; Quadriceps: $t(7)=.475$, $p=.650$; Gluteus Maximus: $t(8)=.211$, $p=.838$).

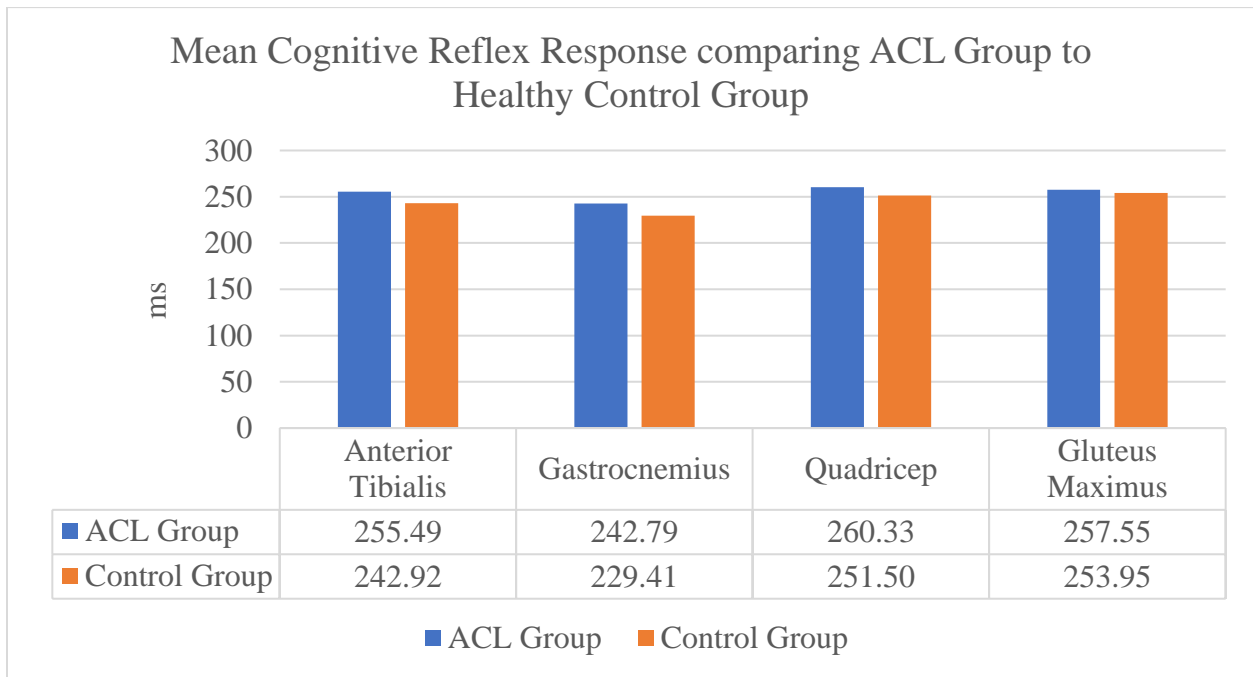

Figure 22 Mean Cognitive Reflex Response comparing ACL Group to Healthy Control Group

Independent samples t-tests were conducted to compare the difference between onset and peak in the cognitive reflex response for participants with an ACL reconstruction as compared to participants with healthy knees, shown in Figure 23. The results were not statistically significant between groups for the difference between onset and peak for the cognitive reflex response across

all four muscles (Anterior Tibialis: $t(8)=-.321$, $p=.756$; Gastrocnemius: $t(8)=-.645$, $p=.537$; Quadricep: $t(8)=-1.410$, $p=.196$; Gluteus Maximus: $t(8)=-1.118$, $p=.296$). The difference in timing between the reflex response and cognitive reflex response is shown in Figure 24.

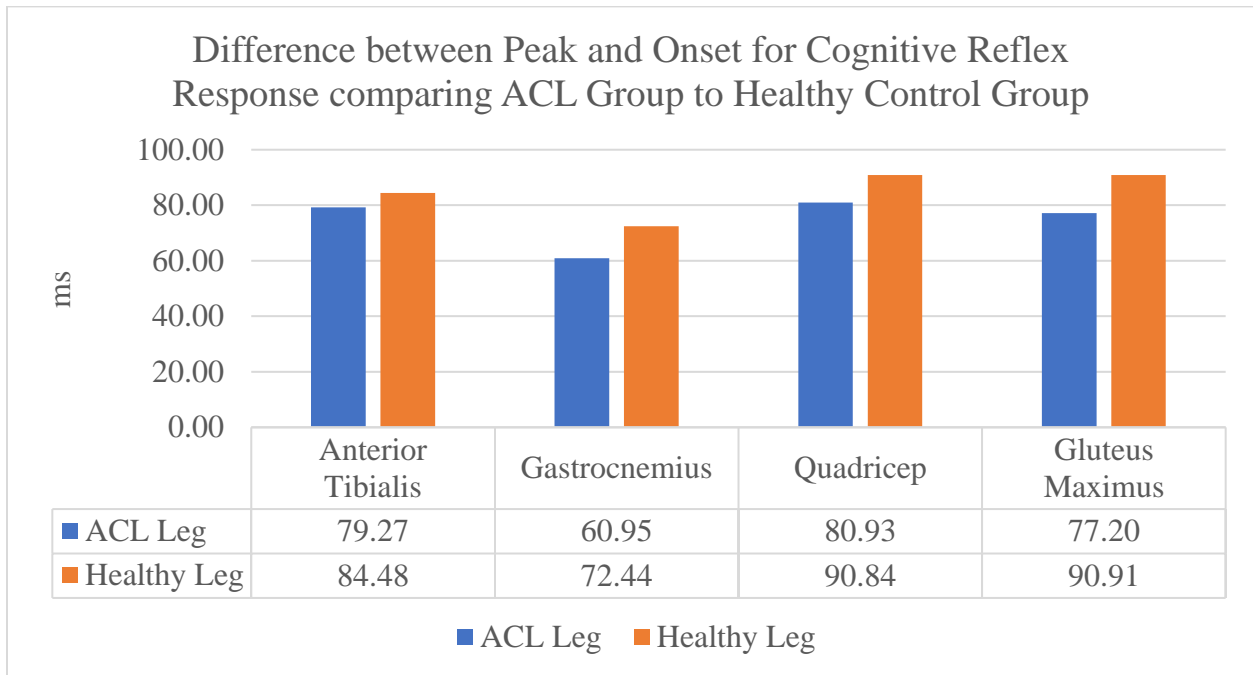

Figure 23 Difference between Peak and Onset Cognitive Reflex Response Time for ACL Group compared to Healthy Controls

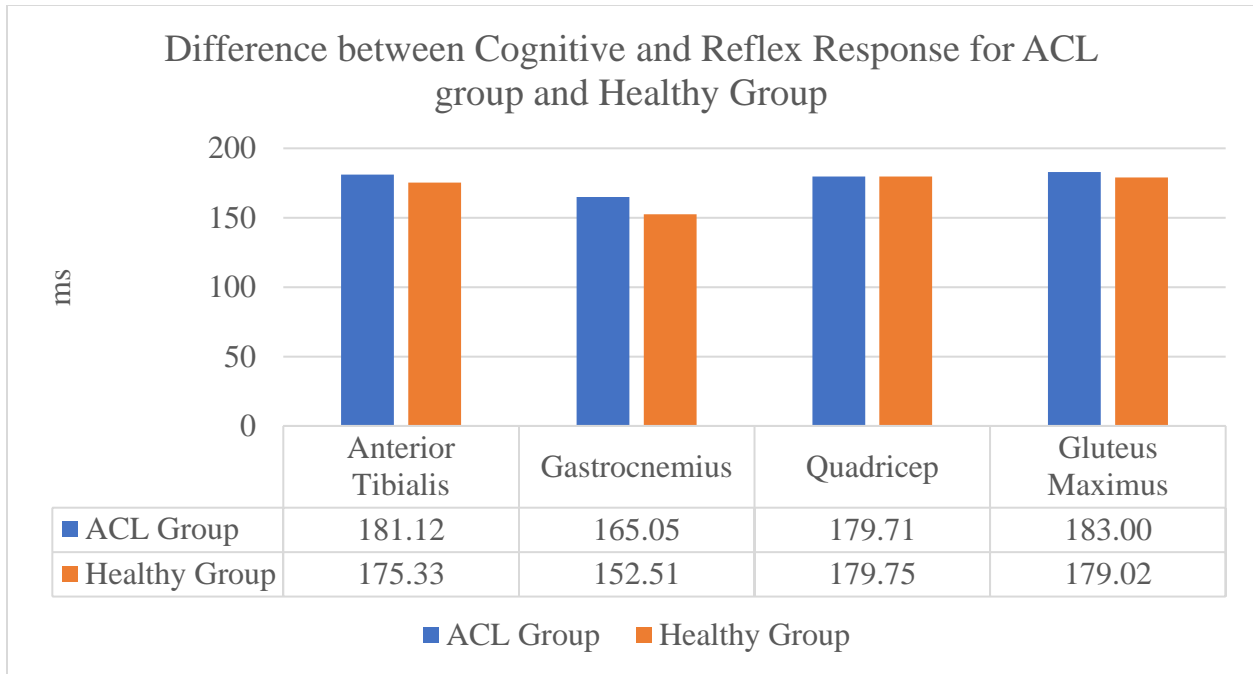

Figure 24 Difference between Cognitive and Reflex Response for ACL group and Healthy Group

3.1.c. Efferent Signals from the Motor Cortex

The mean efferent signal times from the motor cortex (Time from P100 at Cz to second peak EMG contraction) are shown for each participant in Table 3.

Participant	Anterior Tibialis	Gastrocnemius	Quadriceps	Gluteus Maximus
*3	138.20	134.69	na	142.25
8	128.99	105.26	138.97	127.95
*4	104.66	96.62	97.13	101.28
7	108.24	67.18	110.67	121.89
*5	91.01	51.21	110.70	111.49
1	117.39	109.17	117.67	119.89
*9	133.71	125.19	134.08	122.35
2	107.11	95.52	109.48	110.60
*10	196.88	193.24	197.41	197.38
6	53.88	70.93	81.70	90.41

*Represents ACL participant

Table 3 Efferent Signal Time from Motor Cortex of Individuals matched by BMI and leg dominance

Aggregated Mean Efferent Response times for all participants in the ACL Group in comparison to the Healthy Control Group across all four muscles is shown in Figure 25. The ACL group had a longer mean efferent signal time from the motor cortex to three of the four muscles, though the difference was not statistically significant using independent samples t-tests (Anterior Tibialis: $t(8)=1.330$, $p=.220$; Gastrocnemius: $t(8)=1.228$, $p=.254$; Quadriceps: $t(7)=1.046$, $p=.330$; Gluteus Maximus: $t(8)=1.14$, $p=.287$).

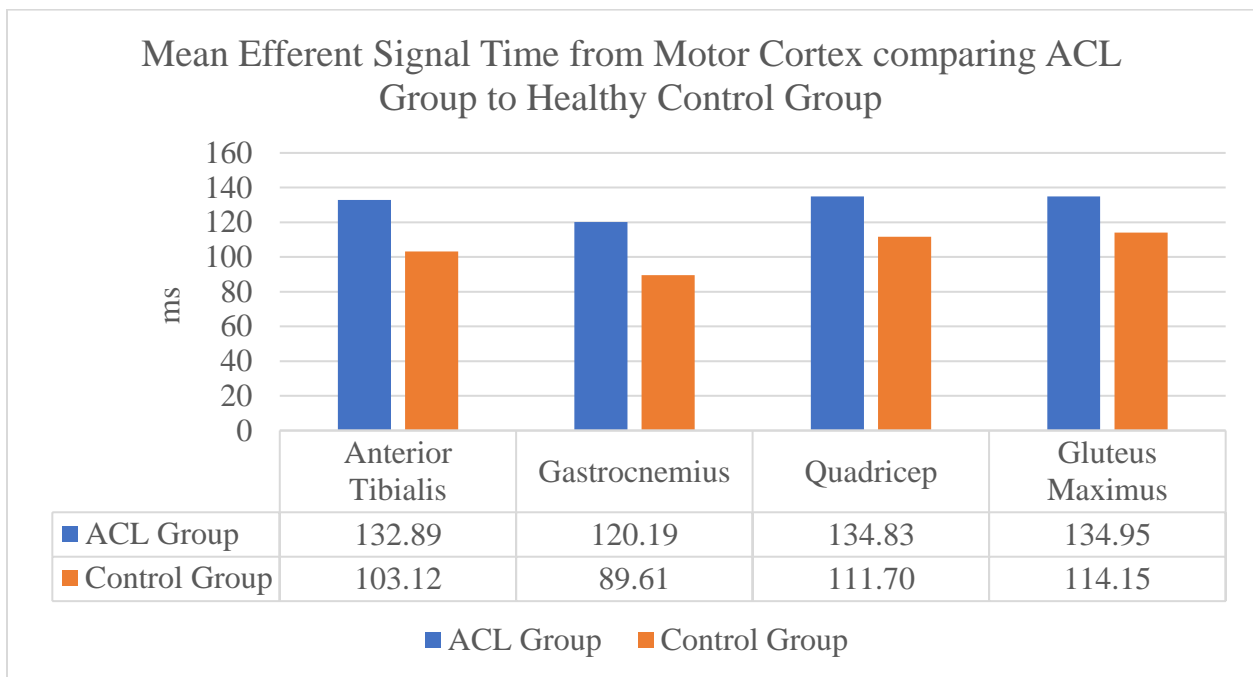

Figure 25 Aggregate Mean Efferent Signals from Motor Cortex for ACL Group and Healthy Controls

3.1.d. Afferent Signals to the Motor Cortex

The mean afferent signal times to the motor cortex (Time from platform stimulus to N100 at Cz) are shown for each participant in Table 4.

Participant	Average Time
3*	111
8	110
4*	154
7	153
5*	136
1	158
9*	108
2	155
10*	104
6	123

*Represents ACL participant

Table 4 Afferent Signal Time to Motor Cortex

The ACL group had slightly faster afferent signal time to the motor cortex as shown in Figure 26, however, the difference was not statistically significant using independent samples t-test ($t(8) = -1.253, p = .245$).

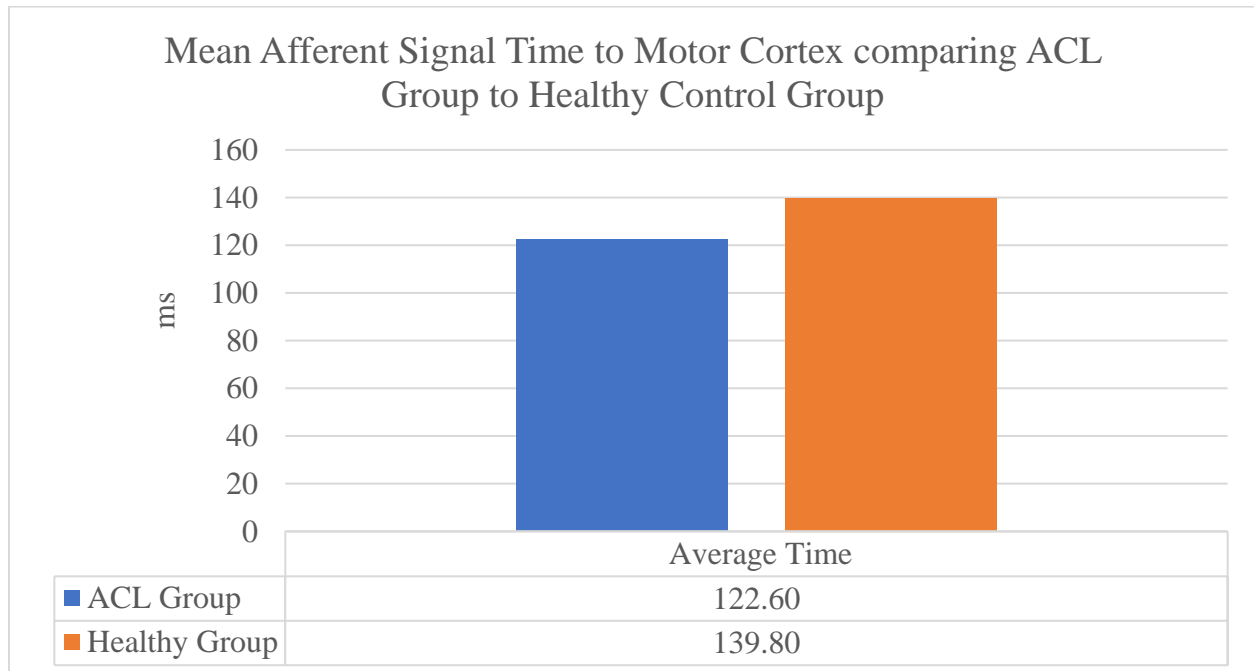

Figure 26 Mean Afferent Signal Time to Motor Cortex

3.1.e. Cognitive Processing Time

The mean cognitive processing time (time from N100 at Cz to P300 at Cz) for each participant is presented in Table 5.

Participant	Average Time
3*	147
8	122
4*	124
7	69
5*	83
1	164
9*	148
2	79
10*	147
6	141

*Represents ACL participant

Table 5 Cognitive Processing Time in Motor Cortex of Individuals

The ACL group had longer mean cognitive processing time as compared to the healthy control group, however, the difference was not statistically significant using independent samples t-test ($t(8)=-.673, p=.250$).

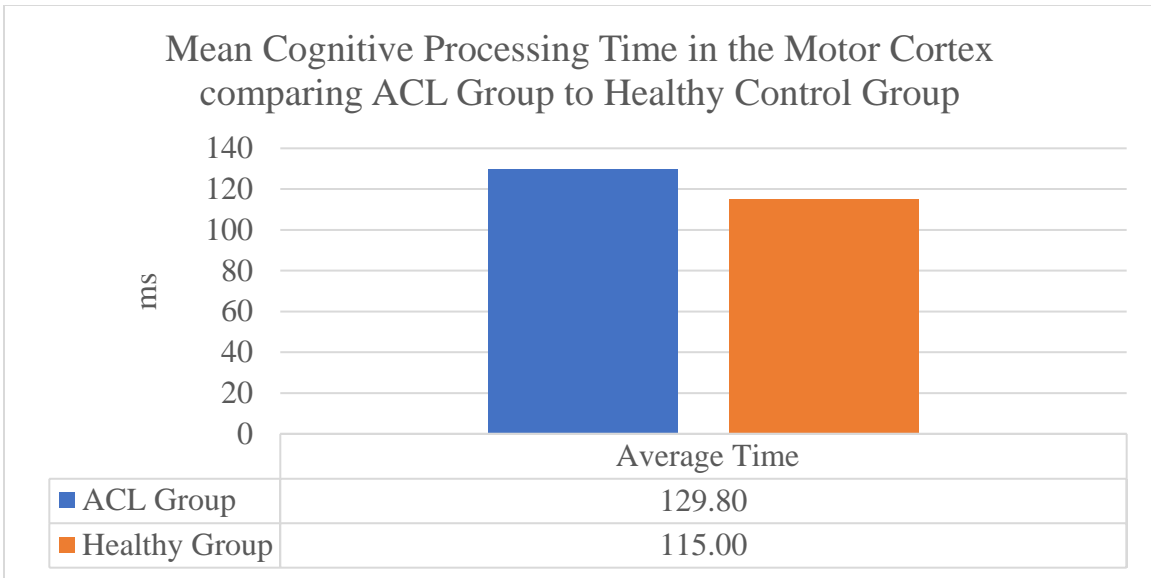

Figure 27 Mean Cognitive Processing Time in the Motor Cortex

3.2 ACL leg vs Healthy leg within ACL participant

In this set of analyses, only participants who had a reconstructed ACL were included. Analyses were done comparing ACL Reconstructed legs and the same participants' healthy legs both in aggregate as well as using a within subjects' analysis. Both results are presented.

3.2.a. Reflex Response within ACL Participants

The mean reflex response time (Time from the perturbation stimulus to the first peak contraction) is shown for each participant and each leg in Table 6.

Participant	Leg	Anterior Tibialis	Gastrocnemius	Quadriceps	Gluteus Maximus
3	ACL	52.96	53.14	na	54.86
	Healthy	54.60	65.00	51.28	56.43
4	ACL	73.34	96.87	79.41	84.30
	Healthy	74.66	70.03	81.27	75.49
5	ACL	73.70	70.11	72.07	66.41
	Healthy	99.17	73.97	74.85	83.28
9	ACL	62.70	59.47	62.72	65.86
	Healthy	68.72	83.62	73.13	71.56
10	ACL	109.15	109.12	108.29	101.30
	Healthy	105.33	103.74	96.08	90.04

Table 6 Reflex Response of ACL Participants

Figure 28 displays the aggregate Mean Reflex Response time comparing healthy and ACL reconstructed legs from ACL Participants. There is variability across muscles, but the data suggests that the ACL legs may be slightly faster on average than the healthy legs for three of the four muscles. Paired t-tests were not statistically significant (Anterior Tibialis: $t(4)=-1.206$; $p=.294$; Gastrocnemius: $t(4)=-.178$; $p=.867$; Quadricep: $t(3)=-.151$; $p=.890$; Gluteus Maximus: $t(4)=-.160$; $p=.881$).

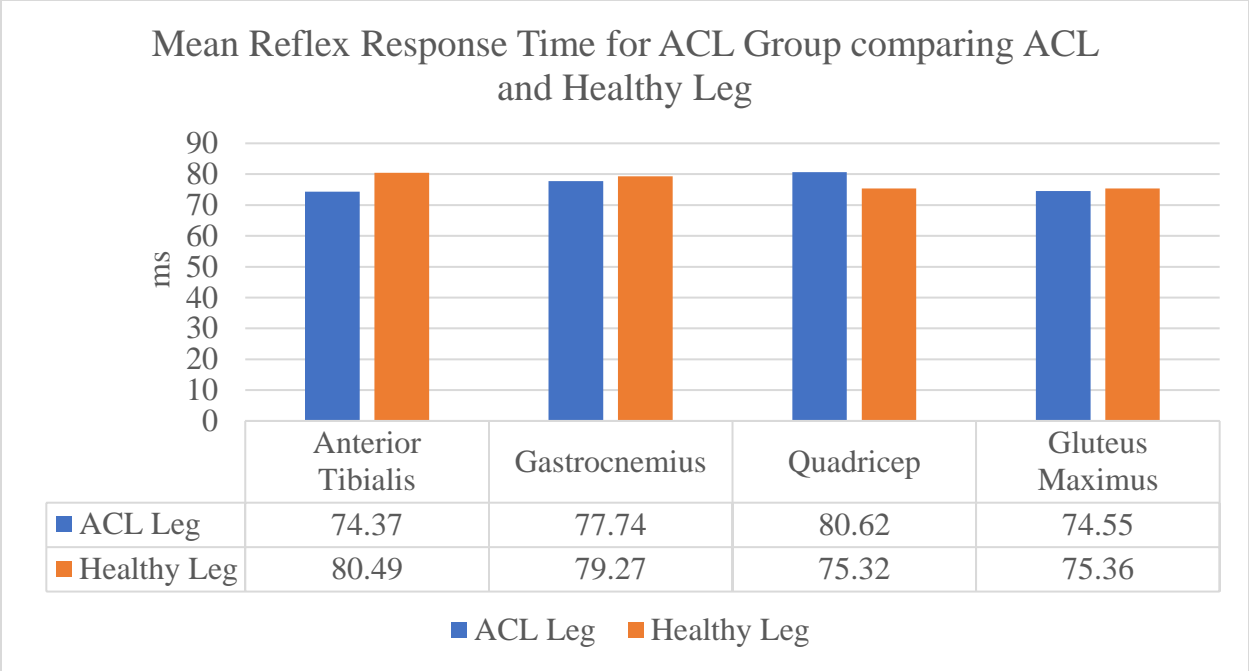

Figure 28 Mean Reflex Response Times within ACL Participants

Paired samples t-tests were conducted to examine the difference between onset and peak for the reflex response within ACL participants comparing their ACL leg and healthy leg, shown in Figure 29. Statistically significant differences were not detected for the reflex response between onset and peak across all four muscles (Anterior Tibialis: $t(4)=-.307$, $p=.774$; Gastrocnemius: $t(4)=-.122$, $p=.909$; Quadriceps: $t(3)=.632$, $p=.572$; Gluteus Maximus: $t(4)=.117$, $p=.912$).

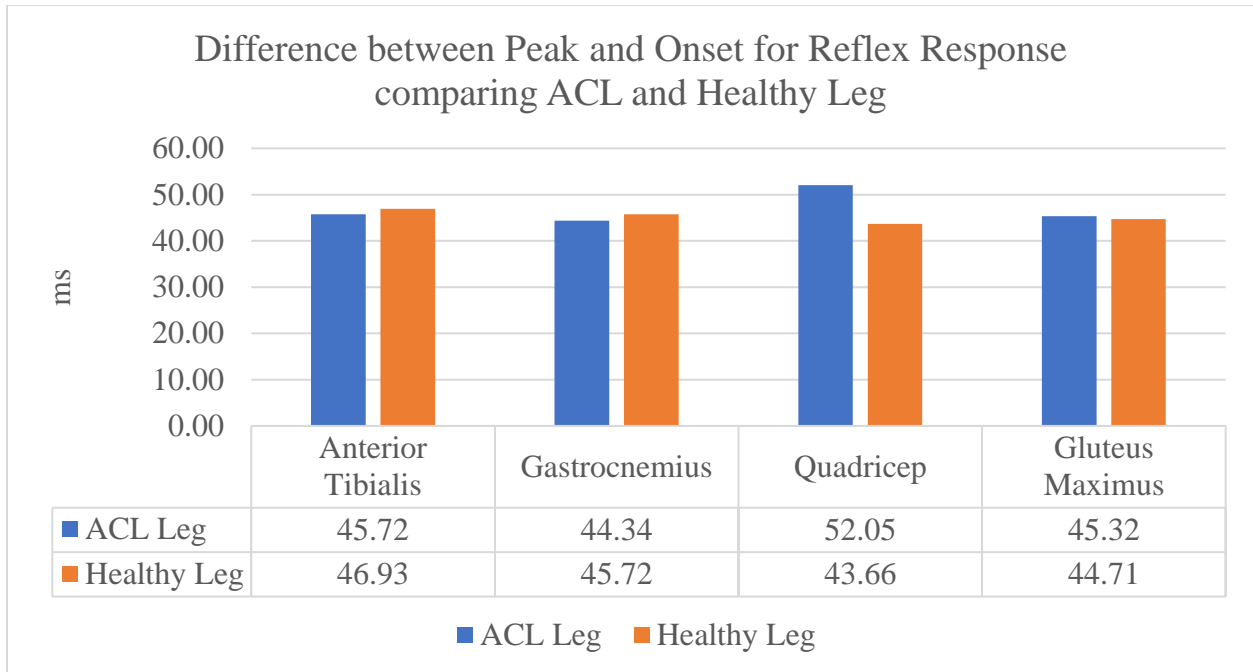

Figure 29 Difference between Peak and Onset Reflex Response Times within ACL Participants

In a pair-wise comparison, differences were calculated in reflex response time between each participant's healthy leg and ACL leg. The results are shown in Figure 30. Differences that are positive indicate that that ACL leg is faster and those that are negative suggest the healthy leg is faster. It is apparent that there is a fair amount of consistency within participants across muscles. Three participants had a faster reflex response in their ACL leg and two had faster reflex response in their healthy leg.

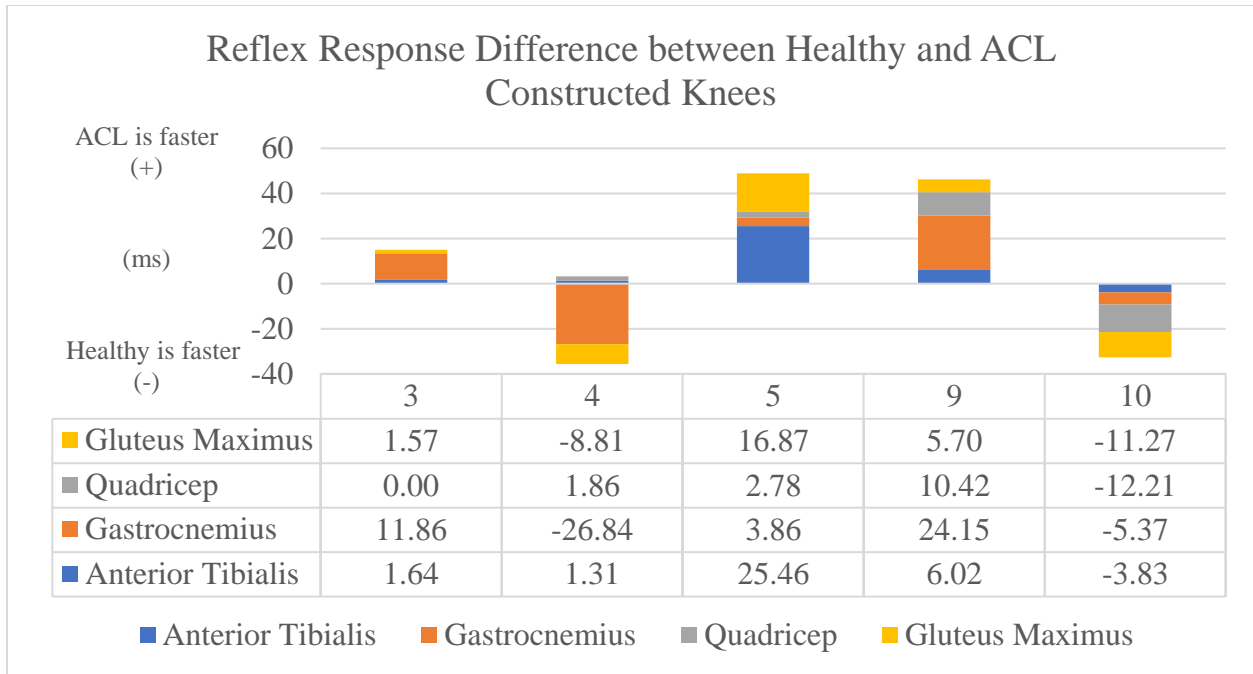

Figure 30 Reflex Response Differences within ACL Participants

3.2.b. Cognitive Reflex Response within ACL Participants

The mean cognitive reflex response time (Time from the perturbation stimulus to the second peak contraction) is shown for each leg for each ACL participant from in Table 7.

Participant	Leg	Anterior Tibialis	Gastrocnemius	Quadriceps	Gluteus Maximus
3	ACL	249.20	245.69	na	253.25
	Healthy	247.32	181.59	242.57	230.03
4	ACL	258.66	250.62	251.13	255.28
	Healthy	273.19	254.10	272.81	264.96
5	ACL	227.01	187.21	246.70	247.49
	Healthy	245.72	277.81	274.17	263.15
9	ACL	241.71	233.19	242.08	230.35
	Healthy	255.55	222.07	243.43	251.30
10	ACL	300.88	297.24	301.41	301.38
	Healthy	302.26	300.73	293.63	303.23

Table 7 Cognitive Reflex Response of ACL Participants

Examining ACL participants' ACL reconstructed and healthy knees in aggregate shows a slight difference between legs with ACL legs displaying faster cognitive reflex response times as compared to healthy legs as shown in Figure 31. Paired t-tests were not statistically significant (Anterior Tibialis: $t(4)=-2.314$, $p=.082$; Gastrocnemius: $t(4)=-.180$, $p=.866$; Quadricep: $t(3)=-1.284$, $p=.289$; Gluteus Maximus: $t(4)=-.645$, $p=.554$).

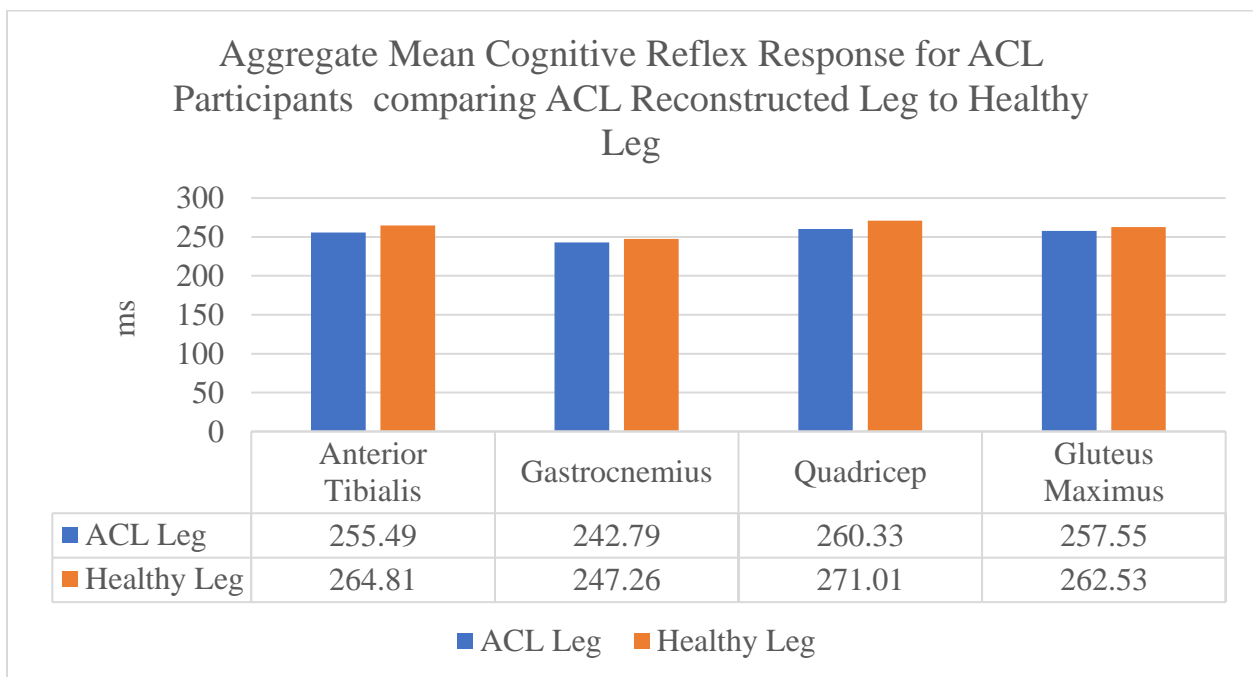

Figure 31 Aggregate Mean Cognitive Reflex Response for ACL Participants

Paired samples t-tests were conducted to examine the difference between onset and peak for the cognitive reflex response within ACL participants comparing their ACL leg and healthy leg, shown in Figure 32. Statistically significant differences were not detected for the cognitive reflex response between onset and peak across all four muscles (Anterior Tibialis: $t(4)=-1.840$, $p=.140$; Gastrocnemius: $t(4)=-.659$, $p=.546$; Quadricep: $t(3)=-1.310$, $p=.260$; Gluteus Maximus: $t(4)=-1.117$, $p=.327$). The difference in timing between the reflex response and cognitive reflex response is shown in Figure 33.

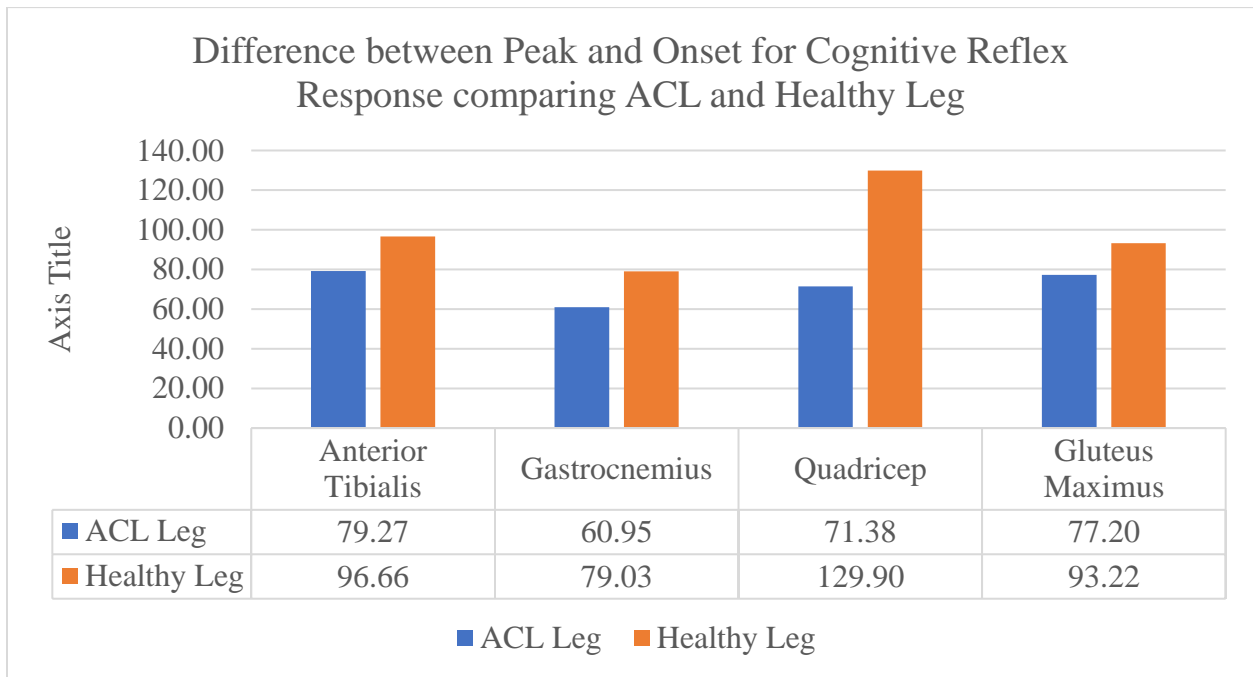

Figure 32 Difference between Peak and Onset Cognitive Reflex Response Times within ACL Participants

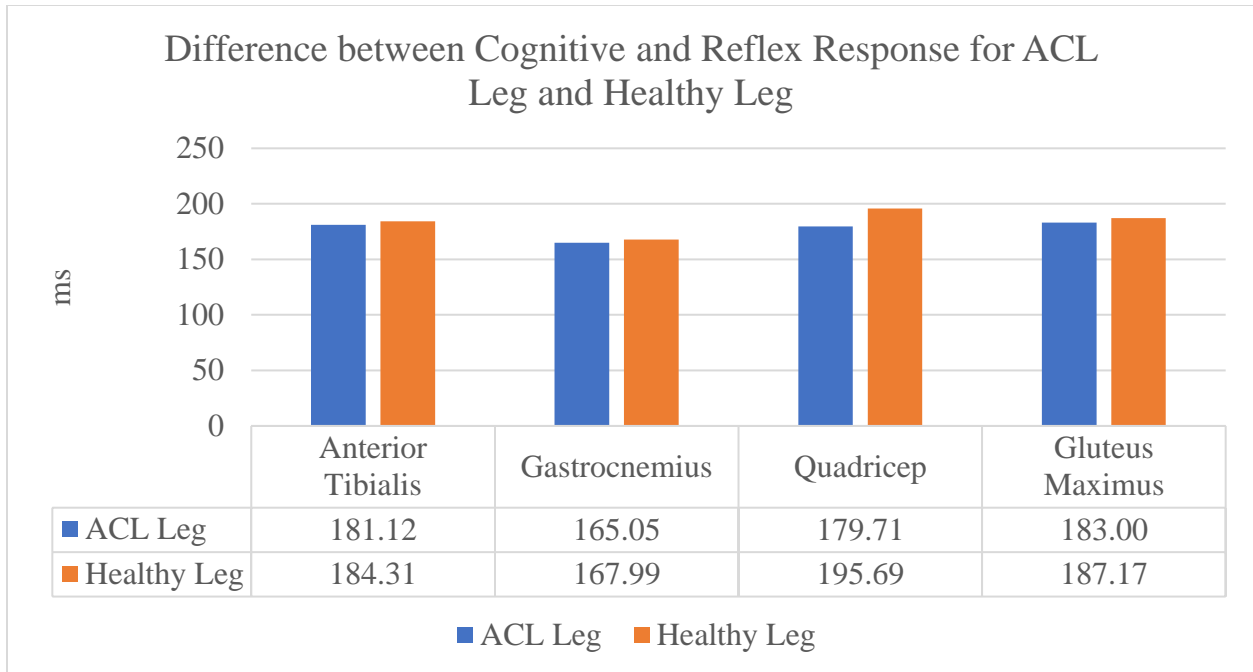

Figure 33 Difference between Cognitive and Reflex Response for ACL Leg and Healthy Leg

In a pair-wise comparison, differences were calculated in cognitive reflex response time between each participant's healthy leg and ACL leg. The results are shown in Figure 34. Differences that are positive indicate that that ACL leg is faster and those that are negative suggest the healthy leg is faster. There was only one participant for whom the ACL leg was much faster.

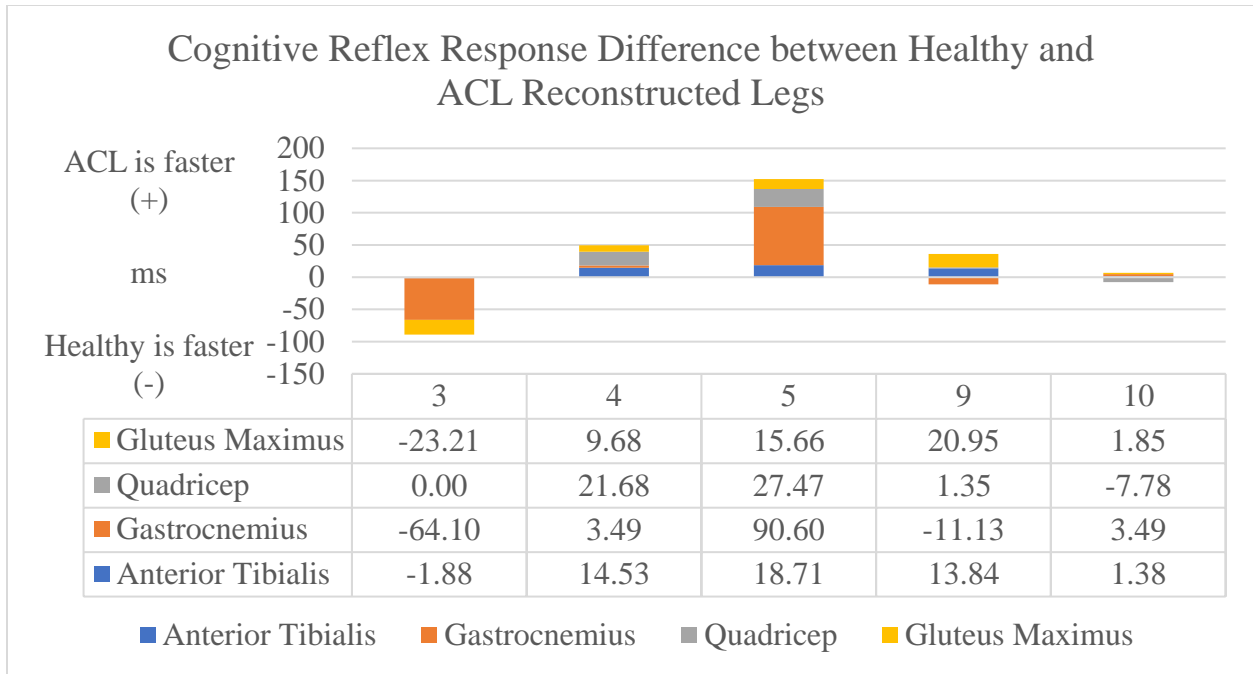

Figure 34 Cognitive Reflex Response Differences within ACL Participants

3.2.c. Efferent signals from the Motor Cortex

The mean efferent signal times from the motor cortex (Time from P100 at Cz to second peak EMG contraction) are shown for each leg of each ACL participant in Table 8.

Participant	Leg	Anterior Tibialis	Gastrocnemius	Quadriceps	Gluteus Maximus
3	ACL	138.20	134.69	na	142.25
	Healthy	138.32	72.59	133.57	121.03
4	ACL	104.66	96.62	97.13	101.28
	Healthy	110.19	91.10	109.81	101.96
5	ACL	91.01	51.21	110.70	111.49
	Healthy	88.72	120.81	117.17	106.15
9	ACL	133.71	125.19	134.08	122.35
	Healthy	119.55	86.07	107.43	115.30
10	ACL	196.88	193.24	197.41	197.38
	Healthy	187.26	185.73	178.63	188.23

Table 8 Efferent Signals from the Motor Cortex for ACL Participants

Figure 35 depicts a consistent pattern in the efferent signals from the motor cortex where the healthy leg is faster than the ACL leg across all four muscles. Paired t-tests were not statistically significant (Anterior Tibialis: $t(4)=1.166$, $p=.309$; Gastrocnemius: $t(4)=.401$, $p=.709$; Quadriceps: $t(3)=.689$, $p=.540$; Gluteus Maximus: $t(4)=2.342$, $p=.079$).

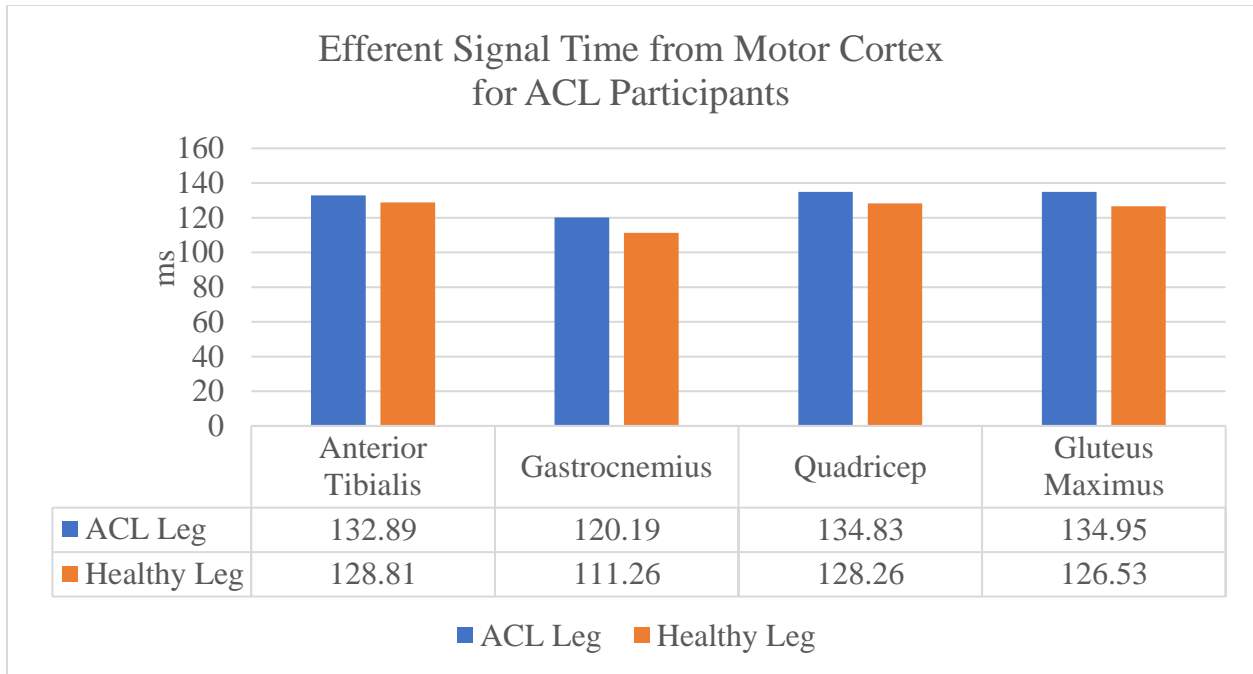

Figure 35 Aggregate Efferent Signal Time from the Motor Cortex for ACL Participants

In a pair-wise comparison, differences were calculated in efferent signals from the motor cortex between each participant’s healthy leg and ACL leg. The results are shown in Figure 36. Differences that are positive indicate that that ACL leg is faster and those that are negative suggest the healthy leg is faster. There does not appear to be a consistent pattern for efferent signals.

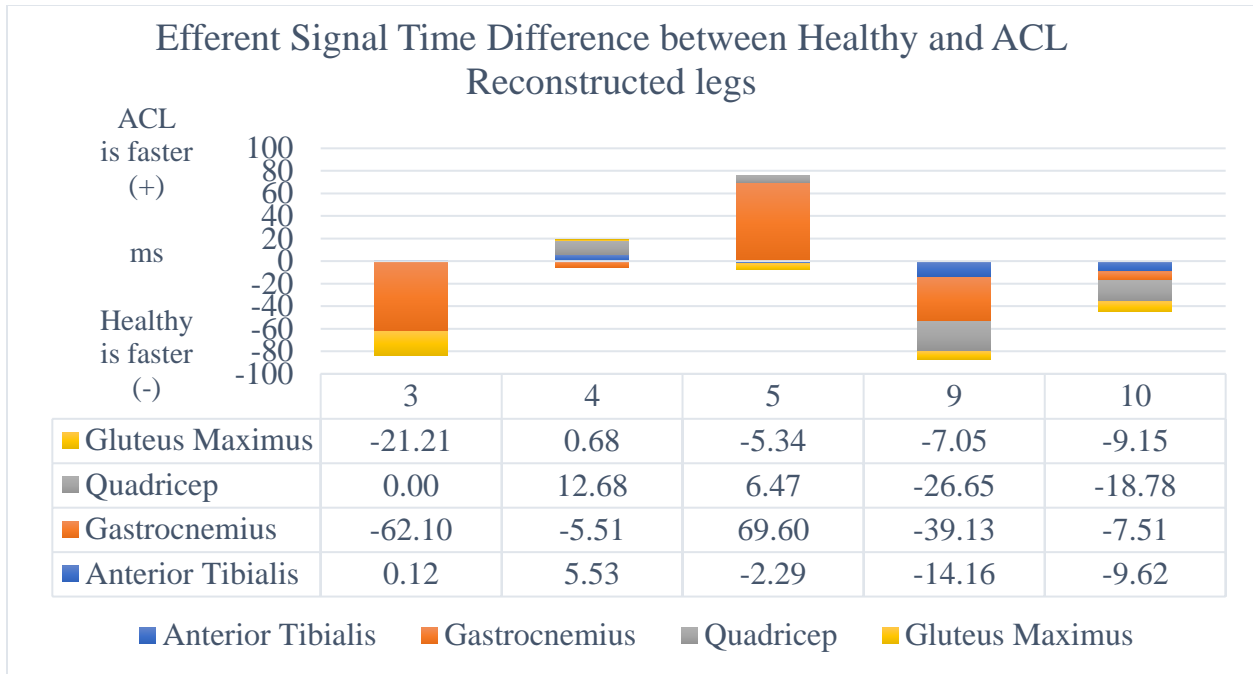

Figure 36 Efferent Signal Time Difference between Healthy and ACL Reconstructed legs

3.2.d. Afferent Signals to the Motor Cortex

The mean afferent signal times to the motor cortex (Time from platform stimulus to N100 at Cz) are shown for each ACL participant in Table 9.

Leg	Average Time
ACL Leg	122.6
Healthy Leg	136

Table 9 Mean Afferent Signal Time to Motor Cortex of ACL Group

When comparing the ACL leg to the healthy leg for ACL participants, the afferent signal time to the motor cortex is faster for the ACL leg as opposed to the healthy leg. Despite the difference, it was not statistically significant using a paired samples t-test ($t(4)=-2.595, p=.060$).

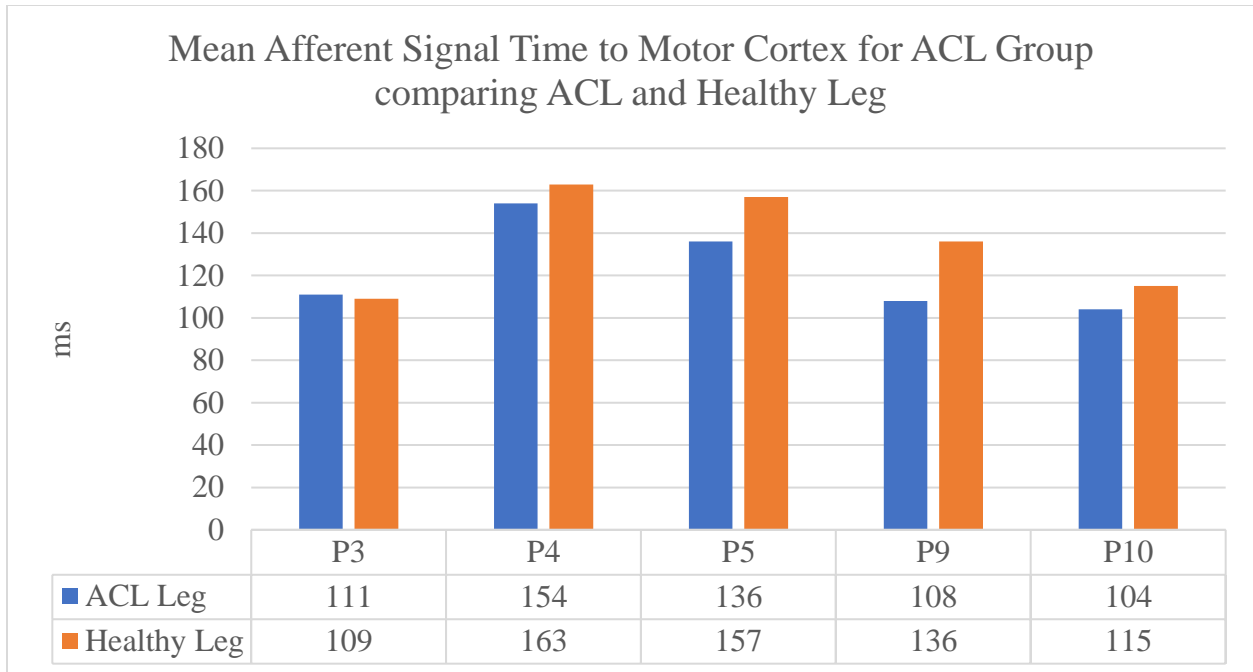

Figure 37 Mean Afferent Signal Time to Motor Cortex

3.2.e. Cognitive Processing Time

The mean cognitive processing time (time from N100 at Cz to P300 at Cz) for each ACL participant is presented in Table 10.

Leg	Average Time
ACL Leg	129.8
Healthy Leg	96.2

Table 10 Mean Cognitive Processing Time in Motor Cortex of ACL Group

When comparing the ACL reconstructed leg to the healthy leg for the ACL group, the ACL leg was associated with slower cognitive processing time in the motor cortex, however, the difference was not statistically significant using a paired samples t-test ($t(4)=1.855$, $p=.137$).

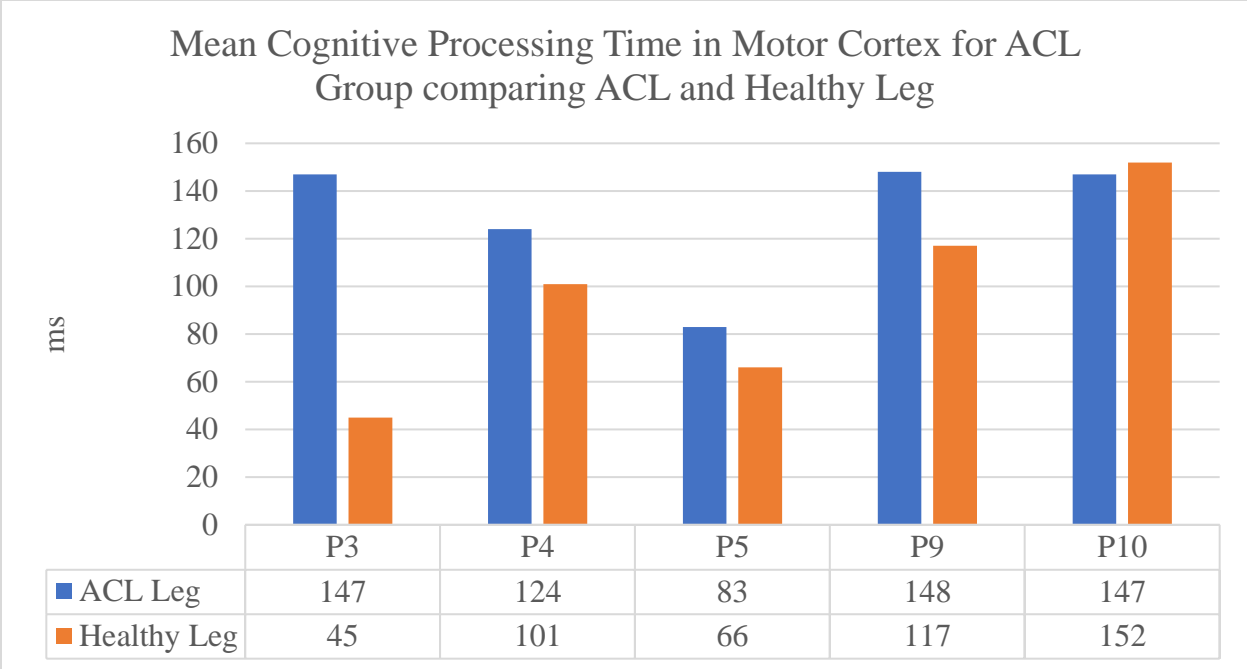

Figure 38 Mean Cognitive Processing Time in Motor Cortex of ACL Group

4. DISCUSSION

When comparing the ACL group to the healthy group, timing deficits for the ACL group were seen in the reflex response, cognitive reflex response, the efferent signals from the motor cortex, and the cognitive processing time. When comparing the ACL and healthy leg within the ACL participants, timing deficits were seen in the ACL leg for cognitive processing time and the efferent signals from the motor cortex.

This study demonstrated a new method of measuring proprioception that allows the timing of responses to be examined using EMG and EEG signals. Using this method, proprioceptive deficits were found in the ACL reconstructed participant's knee compared to healthy controls as well as when compared to the ACL reconstructed participant's own healthy knee as a second control. These deficits were found in the cognitive processing time and the efferent signals from the motor cortex. Both are after the motor cortex has received information that the leg has moved. This indicates that participants who have had an ACL reconstruction take longer for a muscle response from the brain. This may lead to an increased risk of injury because there is a slower response from the brain to the muscles as well as a longer time for the brain to process and decide what to do with that information.

The EEG was an effective tool in observing the ERPs and understanding when information was received and sent from the motor cortex. EMG measurements allowed the timing of muscle responses to be observed after the stimulus. The EMG initial peak contraction time corresponds to the muscle response from the involuntary reflex of the spinal cord and the EMG secondary peak contraction time corresponds to the muscle response from the brain. By using both the EEG and

the EMG simultaneously, it allowed for the comparison of responses from the muscles and brain after the stimulus.

Existing research has previously demonstrated proprioceptive deficits after an ACL reconstruction [6],[18],[5],[3],[7]. The results of this study help to validate this technique of measuring proprioception given similar results to past research. In addition, this method accounts for the timing of signals through the nervous system that may detect communication latencies that can expose an individual at increased risk of subsequent injury. These latencies can be explained by the removal of mechanoreceptors from the injured ACL during reconstructive surgery. With no mechanoreceptors, there is less information being provided to the motor cortex. After surgery the body must compensate with the remaining sensory cells to provide the sensory information from the mechanoreceptors since they are no longer a part of the new ACL graft.

Despite the favorable results from this study, there are some design elements and limitations to consider. A significant challenge throughout this study was finding volunteers for this study who have had an ACL reconstruction in the past 8-18 months. This resulted in a low sample size limiting the power of statistical comparisons. Another consideration in the results of this study was that the volunteers were primarily (9/10) Division I athletes who actively condition every day and/or have engaged in intensive rehabilitation protocols. With this sample group, there may be smaller difference between the groups than one might see with individuals who are less active or older. One suggestion of why there were not ACL deficits or slower times seen in some responses was that through rehabilitation protocols and exercises, muscles began to compensate for the deficits of the ACL, relying mainly on the muscle spindle reactions. Division I athletes rehab more than the average person having an ACL reconstruction, which may account for faster responses within the ACL participants and ACL leg.

This new method of measuring proprioception can be beneficial in the rehabilitation process, but it could also be used as injury prevention. If individuals were aware that they had a proprioceptive deficit, exercises could be done to improve proprioception and reduce risk of an injury. The recurrence of ACL injuries are 60 times more likely than original injuries. Thus, monitoring proprioceptive deficits for those who have had an ACL injury is critical given that they are at a much higher risk of subsequent injury.

In future research, investigators might consider observing proprioception over the course of ACL rehabilitation to track improvements in recovery over time as well as to help determine whether participants are ready to return to activity. In the recovery process, it would be beneficial to know how these deficits improve over time and if there is a certain point at which the improvement stops or changes trajectory. Researchers could observe differences using different speeds of a platform perturbation. This study used a slow perturbation, but it was not explored how changes in perturbation speed effected proprioceptive responses. Another suggestion for further research using this technique is comparing the different rehabilitation protocols to see if there are changes in proprioceptive responses. Additional research could be done on how to make this method more accessible for ACL rehabilitation. This current setup is expensive, time consuming, and doesn't provide immediate feedback for use in a clinical setting. However, all these areas can be improved for implementation by physicians and physical therapists. Capitalizing on the growth of biosensors, products such as Bluetooth EEG and EMG sensors paired with a mobile application could analyze the signals instantly, making this method more accessible to users in real time.

LIST OF REFERENCES

- [1] "Anterior Cruciate Ligament (ACL) Injuries - OrthoInfo - AAOS", *Orthoinfo.aaos.org*, 2019. [Online]. Available: <http://orthoinfo.aaos.org/topic.cfm?topic=A00549>. [Accessed: 18- Mar- 2018].
- [2] "ACL injury - Symptoms and causes", *Mayo Clinic*, 2019. [Online]. Available: <https://www.mayoclinic.org/diseases-conditions/acl-injury/symptoms-causes/syc-20350738>. [Accessed: 14- Mar- 2019].
- [3] M. Dhillon, K. Bali and S. Prabhakar, "Differences among mechanoreceptors in healthy and injured anterior cruciate ligaments and their clinical importance", *Muscles, Ligaments, and Tendons Journal*, vol. 2, no. 1, pp. 38-43, 2012.
- [4] M. Solomonow and M. Krogsgaard, "Sensorimotor control of knee stability. A review", *Scandinavian Journal of Medicine and Science in Sports*, vol. 11, no. 2, pp. 64-80, 2001. Available: 10.1034/j.1600-0838.2001.011002064.x.
- [5] N. Relph, L. Herrington and S. Tyson, "The effects of ACL injury on knee proprioception: a meta-analysis", *Physiotherapy*, vol. 100, no. 3, pp. 187-195, 2014. Available: 10.1016/j.physio.2013.11.002.
- [6] L. Y. Griffin, J. Agel, M. J. Albohm, E. A. Arendt, R. W. Dick, W. E. Garrett, J. G. Garrick, T. E. Hewett, L. Huston, M. L. Ireland, R. J. Johnson, W. B. Kibler, S. Lephart, J. L. Lewis, T. N. Lindenfeld, B. R. Mandelbom, P. Marchak, C. C. Teitz, E. M. Wojtys, "Noncontact Anterior Cruciate Ligament Injuries: Risk Factors and Prevention Strategies", *Journal of the American Academy of Orthopaedic Surgeons*, vol. 8, pp. 141-150, 2000
- [7] R. West and C. Harner, "Graft Selection in Anterior Cruciate Ligament Reconstruction", *Journal of the American Academy of Orthopaedic Surgeons*, vol. 13, no. 3, pp. 197-207, 2005. Available: 10.5435/00124635-200505000-00006.
- [8] J. Baumeister, K. Reinecke and M. Weiss, "Changed cortical activity after anterior cruciate ligament reconstruction in a joint position paradigm: an EEG study", *Scandinavian Journal of Medicine & Science in Sports*, vol. 18, no. 4, pp. 473-484, 2007. Available: 10.1111/j.1600-0838.2007.00702.x..
- [9] O. Knezevic, D. Mirkov, M. Kadija, A. Nedeljkovic and S. Jaric, "Asymmetries in explosive strength following anterior cruciate ligament reconstruction", *The Knee*, vol. 21, no. 6, pp. 1039-1045, 2014. Available: 10.1016/j.knee.2014.07.021.
- [10] K. Bali, S. Prabhakar and M. Dhillon, "Proprioception in anterior cruciate ligament deficient knees and its relevance in anterior cruciate ligament reconstruction", *Indian Journal of Orthopaedics*, vol. 45, no. 4, p. 294, 2011. Available: 10.4103/0019-5413.80320.
- [11] P. Godinho, E. Nicoliche, V. Cossich, E. de Sousa, B. Velasques and J. Salles, "Proprioceptive deficit in patients with complete tearing of the anterior cruciate ligament", *Revista Brasileira de Ortopedia (English Edition)*, vol. 49, no. 6, pp. 613-618, 2014. Available: 10.1016/j.rboe.2014.10.007.

- [12] D. Barrett, "Proprioception and function after anterior cruciate reconstruction", *The Journal of Bone and Joint Surgery. British volume*, vol. 73-, no. 5, pp. 833-837, 1991. Available: 10.1302/0301-620x.73b5.1894677.
- [13] S. Lephart, M. Kocher, F. Fu, P. Borsa and C. Harner, "Proprioception following anterior cruciate ligament reconstruction", *Journal of Sports Rehabilitation*, vol. 1, pp. 188-196, 1992. [Accessed 24 March 2019].
- [14] T. Nau, "Regeneration of the anterior cruciate ligament: Current strategies in tissue engineering", *World Journal of Orthopedics*, vol. 6, no. 1, p. 127, 2015. Available: 10.5312/wjo.v6.i1.127.
- [15] J. Nyland, C. Gamble, T. Franklin and D. Caborn, "Permanent knee sensorimotor system changes following ACL injury and surgery", *Knee Surgery, Sports Traumatology, Arthroscopy*, vol. 25, no. 5, pp. 1461-1474, 2017. Available: 10.1007/s00167-017-4432-y.
- [16] N. Adachi, M. Ochi, Y. Uchio, J. Iwasa, K. Ryoke and M. Kuriwaka, "Mechanoreceptors in the anterior cruciate ligament contribute to the joint position sense", *Acta Orthopaedica Scandinavica*, vol. 73, no. 3, pp. 330-334, 2002. Available: 10.1080/000164702320155356.
- [17] J. Baumeister, K. Reinecke, M. Schubert and M. Weiß, "Altered electrocortical brain activity after ACL reconstruction during force control", *Journal of Orthopaedic Research*, vol. 29, no. 9, pp. 1383-1389, 2011. Available: 10.1002/jor.21380.
- [18] S. Arnfred, A. Chen, D. Eder, B. Glenthøj and R. Hemmingsen, "Proprioceptive evoked potentials in man: cerebral responses to changing weight loads on the hand", *Brain and Cognition*, vol. 47, pp. 54-57, 2001.
- [19] D. J. Creel, "Visually Evoked Potentials," *Webvision*. [Online]. Available: <https://webvision.med.utah.edu/book/electrophysiology/visually-evoked-potentials/>. [Accessed: 15-Apr-2019].
- [20] S. Sur and V. K. Sinha, "Event-related potential: An overview," *Industrial psychiatry journal*, 2009. [Online]. Available: <https://www.ncbi.nlm.nih.gov/pmc/articles/PMC3016705/>. [Accessed: 09-Apr-2019].
- [21] N. Relph and L. Herrington, "Knee joint position sense ability in elite athletes who have returned to international level play following ACL reconstruction: A cross-sectional study," *The Knee*, vol. 23, no. 6, pp. 1029–1034, 2016.
- [22] L. Turner, "Development and Testing of a Balance Platform Perturbator for Research in Neuromuscular Physiology and Biomechanics", *UNH Senior Project (ECE791/792)*, 2016
- [23] A. Ritter, S. Reisman and B. Michniak, *Biomedical Engineering Principles*. Boca Raton: Taylor & Francis, 2005.
- [24] A. DigitalOne, "EEG fMRI Brainlatam", *EEG fMRI Brainlatam*, 2019. [Online]. Available: <https://www.brainlatam.com/manufacturers/easycap>. [Accessed: 14- Mar- 2019].
- [25] "Areas of the brain and functions illustration.", *123RF*, 2019. [Online]. Available: https://www.123rf.com/photo_83022411_stock-vector-areas-of-the-brain-and-functions-illustration-.html. [Accessed: 14- Mar- 2019].

- [26] “actiCAP slim / actiCAP snap,” *Brain Products GmbH / Products & Applications / actiCAP slim / actiCAP snap*. [Online]. Available: <https://www.brainproducts.com/productdetails.php?id=68>. [Accessed: 07-Apr-2019].
- [27]“Electromyography (EMG) - Mayo Clinic”, *Mayoclinic.org*, 2019. [Online]. Available: <http://www.mayoclinic.org/tests-procedures/emg/basics/definition/prc-20014183>. [Accessed: 20- Apr- 2018].
- [28] M. R. Tucker, J. Olivier, A. Pagel, H. Bleuler, M. Bouri, O. Lambercy, J. D. R. Millán, R. Riener, H. Vallery, and R. Gassert, “Control strategies for active lower extremity prosthetics and orthotics: a review,” *Journal of NeuroEngineering and Rehabilitation*, vol. 12, no. 1, p. 1, 2015.

APPENDICES

A – Screening Tests

University of New Hampshire

Proprioception After ACL Reconstruction Screening Questionnaire

Teagan Northrup

Name: Gender:

Age:

Height: Weight:

Dominate Leg: (Circle one) R / L

Have you torn your Anterior Cruciate Ligament (ACL)? (Circle one) Yes / No

If so:

Date of Surgery: (Month/Year)

Which leg? (Circle one) R/L

What graft was used? (Circle all that apply)

Hamstring Patella Quadriceps Cadaver N/A

If relevant, when was your last menstrual cycle?

How often do you exercise?

Have you had any other leg injuries? (Circle one) Yes / No

If so, please explain

PAR-Q+

The Physical Activity Readiness Questionnaire for Everyone

Regular physical activity is fun and healthy, and more people should become more physically active every day of the week. Being more physically active is very safe for MOST people. This questionnaire will tell you whether it is necessary for you to seek further advice from your doctor OR a qualified exercise professional before becoming more physically active.

SECTION 1 - GENERAL HEALTH

Please read the 7 questions below carefully and answer each one honestly: check YES or NO.		YES	NO
1.	Has your doctor ever said that you have a heart condition OR high blood pressure?	<input type="checkbox"/>	<input type="checkbox"/>
2.	Do you feel pain in your chest at rest, during your daily activities of living, OR when you do physical activity?	<input type="checkbox"/>	<input type="checkbox"/>
3.	Do you lose balance because of dizziness OR have you lost consciousness in the last 12 months? Please answer NO if your dizziness was associated with over-breathing (including during vigorous exercise).	<input type="checkbox"/>	<input type="checkbox"/>
4.	Have you ever been diagnosed with another chronic medical condition (other than heart disease or high blood pressure)?	<input type="checkbox"/>	<input type="checkbox"/>
5.	Are you currently taking prescribed medications for a chronic medical condition?	<input type="checkbox"/>	<input type="checkbox"/>
6.	Do you have a bone or joint problem that could be made worse by becoming more physically active? Please answer NO if you had a joint problem in the past, but it does not limit your current ability to be physically active. For example, knee, ankle, shoulder or other.	<input type="checkbox"/>	<input type="checkbox"/>
7.	Has your doctor ever said that you should only do medically supervised physical activity?	<input type="checkbox"/>	<input type="checkbox"/>

If you answered NO to all of the questions above, you are cleared for physical activity.



Go to Section 3 to sign the form. You do not need to complete Section 2.

- › Start becoming much more physically active – start slowly and build up gradually.
- › Follow the Canadian Physical Activity Guidelines for your age (www.csep.ca/guidelines).
- › You may take part in a health and fitness appraisal.
- › If you have any further questions, contact a qualified exercise professional such as a CSEP Certified Exercise Physiologist* (CSEP-CEP) or CSEP Certified Personal Trainer* (CSEP-CPT).
- › If you are over the age of 45 yrs. and NOT accustomed to regular vigorous physical activity, please consult a qualified exercise professional (CSEP-CEP) before engaging in maximal effort exercise.



If you answered YES to one or more of the questions above, please GO TO SECTION 2.



Delay becoming more active if:

- › You are not feeling well because of a temporary illness such as a cold or fever – wait until you feel better
- › You are pregnant – talk to your health care practitioner, your physician, a qualified exercise professional, and/or complete the PARmed-X for Pregnancy before becoming more physically active OR
- › Your health changes – please answer the questions on Section 2 of this document and/or talk to your doctor or qualified exercise professional (CSEP-CEP or CSEP-CPT) before continuing with any physical activity programme.

SECTION 2 - CHRONIC MEDICAL CONDITIONS

Please read the questions below carefully and answer each one honestly: check YES or NO.		YES	NO
1.	Do you have Arthritis, Osteoporosis, or Back Problems?	<input type="checkbox"/> If yes, answer questions 1a-1c	<input type="checkbox"/> If no, go to question 2
1a.	Do you have difficulty controlling your condition with medications or other physician-prescribed therapies? (Answer NO if you are not currently taking medications or other treatments)	<input type="checkbox"/>	<input type="checkbox"/>
1b.	Do you have joint problems causing pain, a recent fracture or fracture caused by osteoporosis or cancer, displaced vertebra (e.g., spondylolisthesis), and/or spondylolysis/pars defect (a crack in the bony ring on the back of the spinal column)?	<input type="checkbox"/>	<input type="checkbox"/>
1c.	Have you had steroid injections or taken steroid tablets regularly for more than 3 months?	<input type="checkbox"/>	<input type="checkbox"/>
2.	Do you have Cancer of any kind?	<input type="checkbox"/> If yes, answer questions 2a-2b	<input type="checkbox"/> If no, go to question 3
2a.	Does your cancer diagnosis include any of the following types: lung/bronchogenic, multiple myeloma (cancer of plasma cells), head, and neck?	<input type="checkbox"/>	<input type="checkbox"/>
2b.	Are you currently receiving cancer therapy (such as chemotherapy or radiotherapy)?	<input type="checkbox"/>	<input type="checkbox"/>
3.	Do you have Heart Disease or Cardiovascular Disease? This includes Coronary Artery Disease, High Blood Pressure, Heart Failure, Diagnosed Abnormality of Heart Rhythm	<input type="checkbox"/> If yes, answer questions 3a-3e	<input type="checkbox"/> If no, go to question 4
3a.	Do you have difficulty controlling your condition with medications or other physician-prescribed therapies? (Answer NO if you are not currently taking medications or other treatments)	<input type="checkbox"/>	<input type="checkbox"/>
3b.	Do you have an irregular heart beat that requires medical management? (e.g. atrial fibrillation, premature ventricular contraction)	<input type="checkbox"/>	<input type="checkbox"/>
3c.	Do you have chronic heart failure?	<input type="checkbox"/>	<input type="checkbox"/>
3d.	Do you have a resting blood pressure equal to or greater than 160/90 mmHg with or without medication? (Answer YES if you do not know your resting blood pressure)	<input type="checkbox"/>	<input type="checkbox"/>
3e.	Do you have diagnosed coronary artery (cardiovascular) disease and have not participated in regular physical activity in the last 2 months?	<input type="checkbox"/>	<input type="checkbox"/>
4.	Do you have any Metabolic Conditions? This includes Type 1 Diabetes, Type 2 Diabetes, Pre-Diabetes	<input type="checkbox"/> If yes, answer questions 4a-4c	<input type="checkbox"/> If no, go to question 5
4a.	Is your blood sugar often above 13.0 mmol/L? (Answer YES if you are not sure)	<input type="checkbox"/>	<input type="checkbox"/>
4b.	Do you have any signs or symptoms of diabetes complications such as heart or vascular disease and/or complications affecting your eyes, kidneys, and the sensation in your toes and feet?	<input type="checkbox"/>	<input type="checkbox"/>
4c.	Do you have other metabolic conditions (such as thyroid disorders, pregnancy-related diabetes, chronic kidney disease, liver problems)?	<input type="checkbox"/>	<input type="checkbox"/>
5.	Do you have any Mental Health Problems or Learning Difficulties? This includes Alzheimer's, Dementia, Depression, Anxiety Disorder, Eating Disorder, Psychotic Disorder, Intellectual Disability, Down Syndrome)	<input type="checkbox"/> If yes, answer questions 5a-5b	<input type="checkbox"/> If no, go to question 6
5a.	Do you have difficulty controlling your condition with medications or other physician-prescribed therapies? (Answer NO if you are not currently taking medications or other treatments)	<input type="checkbox"/>	<input type="checkbox"/>
5b.	Do you also have back problems affecting nerves or muscles?	<input type="checkbox"/>	<input type="checkbox"/>

Please read the questions below carefully and answer each one honestly: check YES or NO.		YES	NO
6.	Do you have a Respiratory Disease? This includes Chronic Obstructive Pulmonary Disease, Asthma, Pulmonary High Blood Pressure	<input type="checkbox"/> If yes, answer questions 6a-6d	<input type="checkbox"/> If no, go to question 7
	6a. Do you have difficulty controlling your condition with medications or other physician-prescribed therapies? (Answer NO if you are not currently taking medications or other treatments)	<input type="checkbox"/>	<input type="checkbox"/>
	6b. Has your doctor ever said your blood oxygen level is low at rest or during exercise and/or that you require supplemental oxygen therapy?	<input type="checkbox"/>	<input type="checkbox"/>
	6c. If asthmatic, do you currently have symptoms of chest tightness, wheezing, laboured breathing, consistent cough (more than 2 days/week), or have you used your rescue medication more than twice in the last week?	<input type="checkbox"/>	<input type="checkbox"/>
	6d. Has your doctor ever said you have high blood pressure in the blood vessels of your lungs?	<input type="checkbox"/>	<input type="checkbox"/>
7.	Do you have a Spinal Cord Injury? This includes Tetraplegia and Paraplegia	<input type="checkbox"/> If yes, answer questions 7a-7c	<input type="checkbox"/> If no, go to question 8
	7a. Do you have difficulty controlling your condition with medications or other physician-prescribed therapies? (Answer NO if you are not currently taking medications or other treatments)	<input type="checkbox"/>	<input type="checkbox"/>
	7b. Do you commonly exhibit low resting blood pressure significant enough to cause dizziness, light-headedness, and/or fainting?	<input type="checkbox"/>	<input type="checkbox"/>
	7c. Has your physician indicated that you exhibit sudden bouts of high blood pressure (known as Autonomic Dysreflexia)?	<input type="checkbox"/>	<input type="checkbox"/>
8.	Have you had a Stroke? This includes Transient Ischemic Attack (TIA) or Cerebrovascular Event	<input type="checkbox"/> If yes, answer questions 8a-c	<input type="checkbox"/> If no, go to question 9
	8a. Do you have difficulty controlling your condition with medications or other physician-prescribed therapies? (Answer NO if you are not currently taking medications or other treatments)	<input type="checkbox"/>	<input type="checkbox"/>
	8b. Do you have any impairment in walking or mobility?	<input type="checkbox"/>	<input type="checkbox"/>
	8c. Have you experienced a stroke or impairment in nerves or muscles in the past 6 months?	<input type="checkbox"/>	<input type="checkbox"/>
9.	Do you have any other medical condition not listed above or do you live with two chronic conditions?	<input type="checkbox"/> If yes, answer questions 9a-c	<input type="checkbox"/> If no, read the advice on page 4
	9a. Have you experienced a blackout, fainted, or lost consciousness as a result of a head injury within the last 12 months OR have you had a diagnosed concussion within the last 12 months?	<input type="checkbox"/>	<input type="checkbox"/>
	9b. Do you have a medical condition that is not listed (such as epilepsy, neurological conditions, kidney problems)?	<input type="checkbox"/>	<input type="checkbox"/>
	9c. Do you currently live with two chronic conditions?	<input type="checkbox"/>	<input type="checkbox"/>

Please proceed to Page 4 for recommendations for your current medical condition and sign this document.

PAR-Q+



If you answered NO to all of the follow-up questions about your medical condition, you are ready to become more physically active:

- › It is advised that you consult a qualified exercise professional (e.g., a CSEP-CEP or CSEP-CPT) to help you develop a safe and effective physical activity plan to meet your health needs.
- › You are encouraged to start slowly and build up gradually – 20-60 min. of low- to moderate-intensity exercise, 3-5 days per week including aerobic and muscle strengthening exercises.
- › As you progress, you should aim to accumulate 150 minutes or more of moderate-intensity physical activity per week.
- › If you are over the age of 45 yrs. and NOT accustomed to regular vigorous physical activity, please consult a qualified exercise professional (CSEP-CEP) before engaging in maximal effort exercise.



If you answered YES to one or more of the follow-up questions about your medical condition:

- › You should seek further information from a licensed health care professional before becoming more physically active or engaging in a fitness appraisal and/or visit a or qualified exercise professional (CSEP-CEP) for further information.



Delay becoming more active if:

- › You are not feeling well because of a temporary illness such as a cold or fever – wait until you feel better
- › You are pregnant - talk to your health care practitioner, your physician, a qualified exercise professional, and/or complete the PARmed-X for Pregnancy before becoming more physically active OR
- › Your health changes - please talk to your doctor or qualified exercise professional (CSEP-CEP) before continuing with any physical activity programme.

SECTION 3 - DECLARATION

- › You are encouraged to photocopy the PAR-Q+. You must use the entire questionnaire and NO changes are permitted.
- › The Canadian Society for Exercise Physiology, the PAR-Q+ Collaboration, and their agents assume no liability for persons who undertake physical activity. If in doubt after completing the questionnaire, consult your doctor prior to physical activity.
- › If you are less than the legal age required for consent or require the assent of a care provider, your parent, guardian or care provider must also sign this form.
- › Please read and sign the declaration below:

I, the undersigned, have read, understood to my full satisfaction and completed this questionnaire. I acknowledge that this physical activity clearance is valid for a maximum of 12 months from the date it is completed and becomes invalid if my condition changes. I also acknowledge that a Trustee (such as my employer, community/fitness centre, health care provider, or other designate) may retain a copy of this form for their records. In these instances, the Trustee will be required to adhere to local, national, and international guidelines regarding the storage of personal health information ensuring that they maintain the privacy of the information and do not misuse or wrongfully disclose such information.

NAME _____ DATE _____

SIGNATURE _____ WITNESS _____

SIGNATURE OF PARENT/GUARDIAN/CARE PROVIDER _____

For more information, please contact:
Canadian Society for Exercise Physiology
www.csep.ca

KEY REFERENCES

1. Jamnik VJ, Warburton DER, Makarski J, McKenzie DC, Shephard RJ, Stone J, and Gledhill N. Enhancing the effectiveness of clearance for physical activity participation; background and overall process. APNM 36(51):53-513, 2011.
2. Warburton DER, Gledhill N, Jamnik VK, Bredin SSD, McKenzie DC, Stone J, Charlesworth S, and Shephard RJ. Evidence-based risk assessment and recommendations for physical activity clearance; Consensus Document. APNM 36(51):5266-5298, 2011.

The PAR-Q+ was created using the evidence-based AGREE process (1) by the PAR-Q+Collaboration chaired by Dr. Darren E. R. Warburton with Dr. Norman Gledhill, Dr. Veronica Jamnik, and Dr. Donald C. McKenzie (2). Production of this document has been made possible through financial contributions from the Public Health Agency of Canada and the BC Ministry of Health Services. The views expressed herein do not necessarily represent the views of the Public Health Agency of Canada or BC Ministry of Health Services.



COPYRIGHT © 2012 4 / 4
CSEP approved Sept 12 2011 version

Mini-Mental State Examination (MMSE)

Patient's Name: _____ Date: _____

Instructions: Score one point for each correct response within each question or activity.

Maximum Score	Patient's Score	Questions
5		"What is the year? Season? Date? Day? Month?"
5		"Where are we now? State? County? Town/city? Hospital? Floor?"
3		The examiner names three unrelated objects clearly and slowly, then the instructor asks the patient to name all three of them. The patient's response is used for scoring. The examiner repeats them until patient learns all of them, if possible.
5		"I would like you to count backward from 100 by sevens." (93, 86, 79, 72, 65, ...) Alternative: "Spell WORLD backwards." (D-L-R-O-W)
3		"Earlier I told you the names of three things. Can you tell me what those were?"
2		Show the patient two simple objects, such as a wristwatch and a pencil, and ask the patient to name them.
1		"Repeat the phrase: 'No ifs, ands, or buts.'"
3		"Take the paper in your right hand, fold it in half, and put it on the floor." (The examiner gives the patient a piece of blank paper.)
1		"Please read this and do what it says." (Written instruction is "Close your eyes.")
1		"Make up and write a sentence about anything." (This sentence must contain a noun and a verb.)
1		"Please copy this picture." (The examiner gives the patient a blank piece of paper and asks him/her to draw the symbol below. All 10 angles must be present and two must intersect.) 
30		TOTAL

B – Consent Form

THE UNIVERSITY OF NEW HAMPSHIRE
Informed Consent for Research Involving Human Subjects

CONSENT FOR PARTICIPATION IN RESEARCH

PROJECT TITLE: EEG and EMG Sensorimotor Measurements to Assess Proprioception Following ACL Reconstruction

Principal Investigator: **Teagan Northrup**, Student, Electrical Engineering Major, Department of Electrical and Computer Engineering, UNH
 Dr. Wayne J. Smith, Faculty Mentor, Department of Electrical and Computer Engineering, UNH
 Dr. Ron V. Croce, Faculty Mentor, Department of Kinesiology, UNH

Please read this document carefully and completely. Please ask the research assistant any questions, particularly if you do not understand something. Please do not agree to participate until all your questions have been answered, or until you are sure that you want to participate.

I understand that I must be 18 years of age to participate in this study. I understand that I have been invited with no obligation to participate in a research study being conducted by Ms. Teagan Northrup, Dr. Wayne Smith of the Department of Electrical and Computer Engineering and Dr. Ron Croce of the Department of Kinesiology. I understand that the UNH Institutional Review Board for the Protection of Human Subjects in Research has approved the use of human subjects in this project.

Purpose:

For the purpose of this study, we will be using an EEG and an EMG to compare proprioception in ACL reconstructed knees and healthy controls. We believe that participants with ACL reconstructions will have challenges detecting where one's knee or leg is in space during movement requiring more cognitive and muscular effort to react effectively to stimuli and maintain balance. These challenges are known as proprioceptive deficits and can be observed through the signals between the knee, the muscles and the brain. Using the EEG, we will be looking at signals from the brain (event related potentials from the sensory cortex and parietal

cortex along with the lateral readiness potentials). The EMG will be used to measure muscle activity.

Description of Study:

Forty participants will be fitted with an EEG cap and EMG electrodes on the midpoint of four different leg muscles: tibialis anterior, gastrocnemius, rectus femoris, and gluteus maximus. The participant will stand barefoot on the platform perturbation with feet hip width apart. Earbuds will be worn to drown out the motor actuator prior to the platform perturbation moving. To allow each leg to be individually tested, the leg tested will have the foot firmly planted on the platform while only the toe of the other foot is touching to help with balance. A handrail will be placed next to the platform perturbation in the off chance the participant loses balance.

The participant will participate in a series of trials (a minimum of 100) until 100 valid responses have been conducted. A single trial consists of the participant being perturbed forward at two inches per second for no more than half a second, then perturbed backwards once balance has been regained. Perturbation timing will be randomized between one to five seconds to reduce the anticipated movement. After each set of 25 trials, participants will have two minutes for a sitting or standing break to prevent muscle fatigue. A trial will be invalid if the participant steps or loses balance during the perturbation. Upon completion of 100 responses that are valid the participant will have completed their participation. It is anticipated that the experimental portion will not take any longer than two hours.

Dr. Smith, Dr. Croce, and Ms. Northrup will all have access to data stored on Dr. Croce's UNH Box account. Each participant will be given a study identification number that all data will be saved with. All data will be presented in aggregate and individuals will not be identified in analysis and manuscripts. A hard copy sheet will exist that links each participant with their corresponding code in case participants, IRB or UNH administrators need to review the data under special circumstances. The copy will be in a locked file cabinet in Dr. Croce's office. Any data taken may be used for the senior capstone report, presentation for the Interdisciplinary Science and Engineering Symposium at UNH, future research publications, and Ms. Northrup's master's thesis.

RISKS AND BENEFITS

There is minimal risk associated with this study. To ensure the best experience for participants, a two-minute sitting or standing break every 25 trials will be given to prevent muscle fatigue. While unlikely, it is possible that the participant could lose balance when the platform perturbation moves. To minimize any risk, the participant's hand will be gently touching a hand rail so that can be used to help regain balance if needed. In addition, the platform perturbation is surrounded by padded floor mats. Occasionally, minor skin irritation could occur from the stick-on EMG electrodes and from the gel used in the EEG electrodes. Although the participant is not anticipated to receive any direct benefits by participating, the study can provide the participants and others with ACL injuries an in-depth analysis of the participant's balance response time and whether their proprioception differs between legs. As a benefit to the orthopedic community this study could lead to a new way for orthopedics to measure proprioception and help prevent athletes from reinjuring their knee.

PLEASE READ THE FOLLOWING STATEMENTS AND RESPOND AS TO WHETHER OR NOT YOU ARE WILLING TO PARTICIPATE:

1. I understand that the UNH Institutional Review Board has approved the use of human subjects in this project for a study on the role of the anterior cruciate ligament in proprioception.
2. The experiment has been fully explained to me and all questions have been answered to my complete satisfaction. Furthermore, I understand the scope, aims, and purposes of this research project; the procedures to be followed; and, the expected duration of my participation.
3. Although I understand that the study is not specifically designed to benefit me personally, through this study, scientists may learn more about how sensorimotor systems and anterior cruciate ligament (ACL) are affected after reconstructive surgery.
4. I have received a description of any reasonable foreseeable risks or discomforts associated with me being a subject in this research, have had them explained to me, and understand them. Though injury of any kind is unlikely, I understand that there are minimal risks associated with my participation, however, the researchers will take all necessary precautions to avoid these problems.
5. I have been cleared by a doctor to engage in physical activity
6. I understand that if I am injured or if I require medical treatment, it will be my responsibility to obtain this care and that UNH is not responsible for paying for this care.
7. I understand that my consent to participate is completely voluntary and that I am free to withdraw from the study at any time without penalty. I understand that information that is derived from this study will be treated as confidential, but the researchers cannot guarantee complete confidentiality as there are rare circumstances under which other (such as UNH or regulatory officials) may have access to study data
8. I confirm that no coercion of any kind was used in seeking my consent for participation in this research project.
9. I understand that if I have any questions pertaining to the research, or any research related injury, I have the right to call Dr. Ron Croce at 603-862-2080 (rvc@unh.edu) and/or Teagan Northrup at 413-883-9726 (tfn2000@wildcats.unh.edu) and be given the opportunity to discuss them in confidence. **If you have questions about your rights as a research subject you can contact Melissa McGee in UNH Research Integrity Services at 603-862-2005 or melissa.mcgee@unh.edu to discuss them.**

10. I understand that any information gained about me as a result of participation will be provided to me at the conclusion of the research project, if I request such information.
11. I certify that I have read and fully understand the purpose of this research project and its risks and benefits for me as stated above.

I, _____ CONSENT/DO AGREE to participate in this research project.

I, _____ REFUSE/DO NOT AGREE to participate in this research project.

Signature of participant

Date

I hereby certify that I have given an explanation to the above individual of the study and its risks and potential benefits

Signature of Researcher

Date

C – Recruitment Flyer



HELP UNDERSTAND HEALING AFTER ACL SURGERY

LOOKING FOR STUDY VOLUNTEERS!

This study is comparing participants with ACL reconstructed knees and participants with healthy knees to examine proprioception. In other words, how well can you detect changes in stimuli and maintain your balance. We are using EEGs and EMGs to measure brain and muscle activity during movement. We hope the results may offer a new technique to assist in rehabilitation.



**LOOKING FOR
VOLUNTEERS
AGE 18-30**

**HAVE YOU HAD ACL
RECONSTRUCTION
SURGERY?**

**DO YOU HAVE HEALTHY
KNEES?**

**STUDYING ACL
RESPONSES IN ACL
RECONSTRUCTED AND
HEALTHY KNEES**

ONE 3 HOUR SESSION

INTERESTED?

PLEASE CONTACT:

Teagan Northrup

413-883-9726

tfn2000@wildcats.unh.edu

D – IRB Approval

University of New Hampshire

Research Integrity Services, Service Building
51 College Road, Durham, NH 03824-3585
Fax: 603-862-3564

31-Oct-2017

Northrup, Teagan
Electrical Engineering, Kingsbury Hall
Durham, NH 03824

IRB #: 6775

Study: EEG and EMG Sensorimotor Measurements to Assess Proprioception following ACL Reconstruction

Approval Date: 26-Oct-2017

The Institutional Review Board for the Protection of Human Subjects in Research (IRB) has reviewed and approved the protocol for your study as Expedited as described in Title 45, Code of Federal Regulations (CFR), Part 46, Subsection 110.

Approval is granted to conduct your study as described in your protocol for one year from the approval date above. At the end of the approval period, you will be asked to submit a report with regard to the involvement of human subjects in this study. If your study is still active, you may request an extension of IRB approval.

Researchers who conduct studies involving human subjects have responsibilities as outlined in the document, *Responsibilities of Directors of Research Studies Involving Human Subjects*. This document is available at <http://unh.edu/research/irb-application-resources>. Please read this document carefully before commencing your work involving human subjects.

If you have questions or concerns about your study or this approval, please feel free to contact me at 603-862-2003 or Julie.simpson@unh.edu. Please refer to the IRB # above in all correspondence related to this study. The IRB wishes you success with your research.

For the IRB,



Julie F. Simpson
Director

cc: File
Snarski, Anna
Smith, Wayne

University of New Hampshire

Research Integrity Services, Service Building
51 College Road, Durham, NH 03824-3585
Fax: 603-862-3584

26-Oct-2018

Northrup, Teagan
Electrical Engineering, Kingsbury Hall
Durham, NH 03824

IRB #: 6775

Study: EEG and EMG Sensorimotor Measurements to Assess Proprioception following ACL Reconstruction

Approval Expiration Date: 26-Oct-2019

Modification Approval Date: 24-Oct-2018

Modification: Increased Recruitment

The Institutional Review Board for the Protection of Human Subjects in Research (IRB) has reviewed and approved your modification to this study, as indicated above. Further changes in your study must be submitted to the IRB for review and approval prior to implementation.

Approval for this protocol expires on the date indicated above. At the end of the approval period you will be asked to submit a report with regard to the involvement of human subjects in this study. If your study is still active, you may request an extension of IRB approval.

Researchers who conduct studies involving human subjects have responsibilities as outlined in the document, *Responsibilities of Directors of Research Studies Involving Human Subjects*. This document is available at <http://unh.edu/research/irb-application-resources> or from me.

Note: IRB approval is separate from UNH Purchasing approval of any proposed methods of paying study participants. Before making any payments to study participants, researchers should consult with their BSC or UNH Purchasing to ensure they are complying with institutional requirements. If such institutional requirements are not consistent with the confidentiality or anonymity assurances in the IRB-approved protocol and consent documents, the researcher may need to request a modification from the IRB.

If you have questions or concerns about your study or this approval, please feel free to contact Melissa McGee at 603-862-2005 or melissa.mcgee@unh.edu. Please refer to the IRB # above in all correspondence related to this study. The IRB wishes you success with your research.

For the IRB,



Julie F. Simpson
Director

cc: File
Snarski, Anna
Smith, Wayne

E – Average Cz electrode and CSD Maps

Healthy Participants:

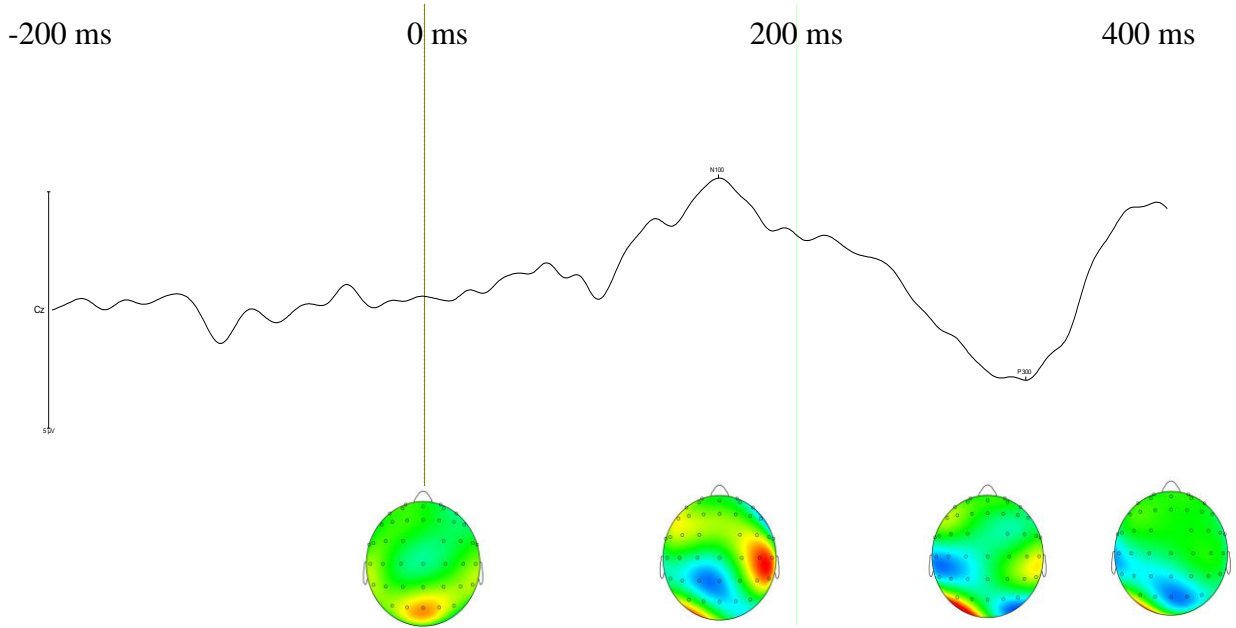

Figure 39 Subject 1

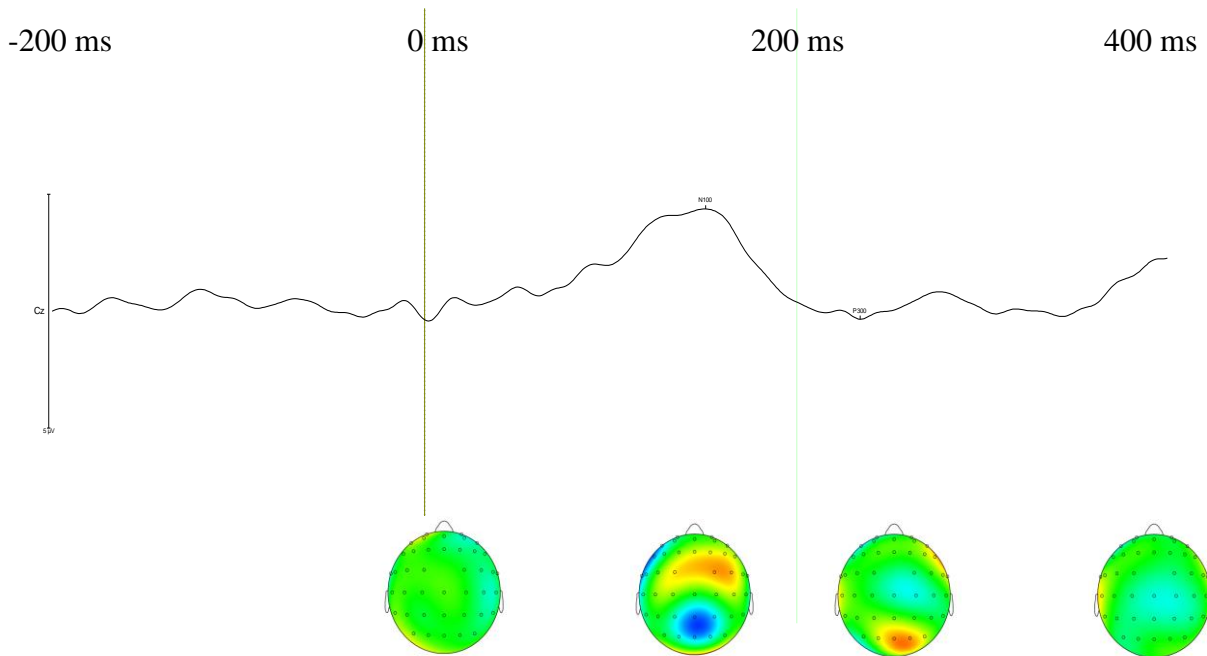

Figure 40 Subject 2

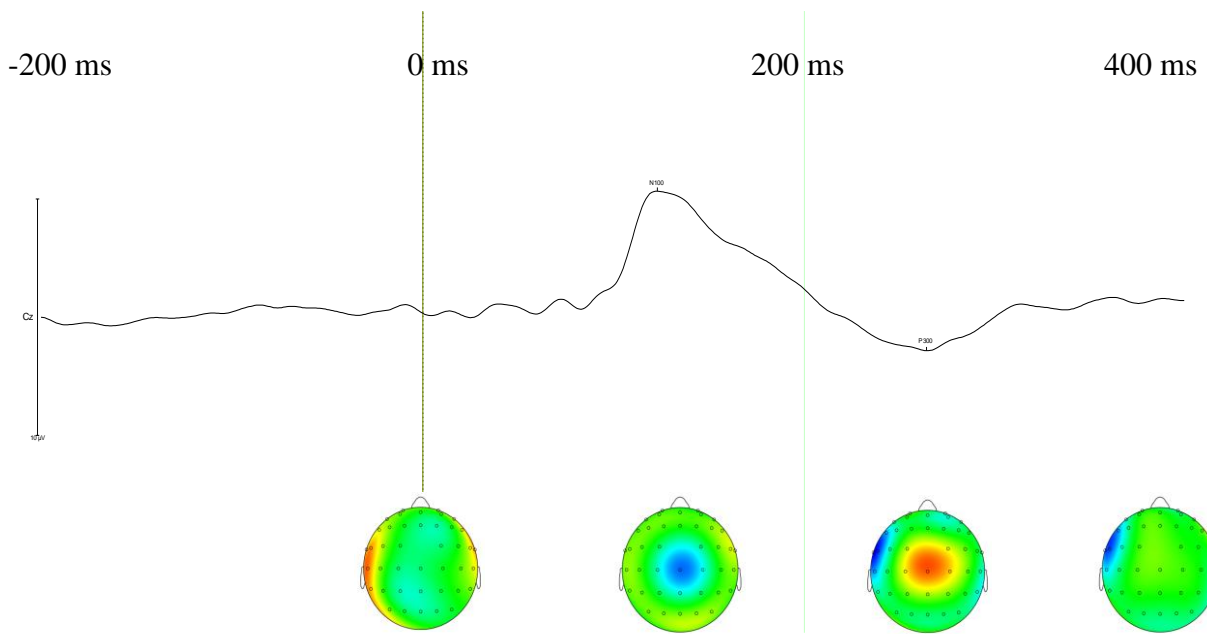

Figure 41 Subject 6

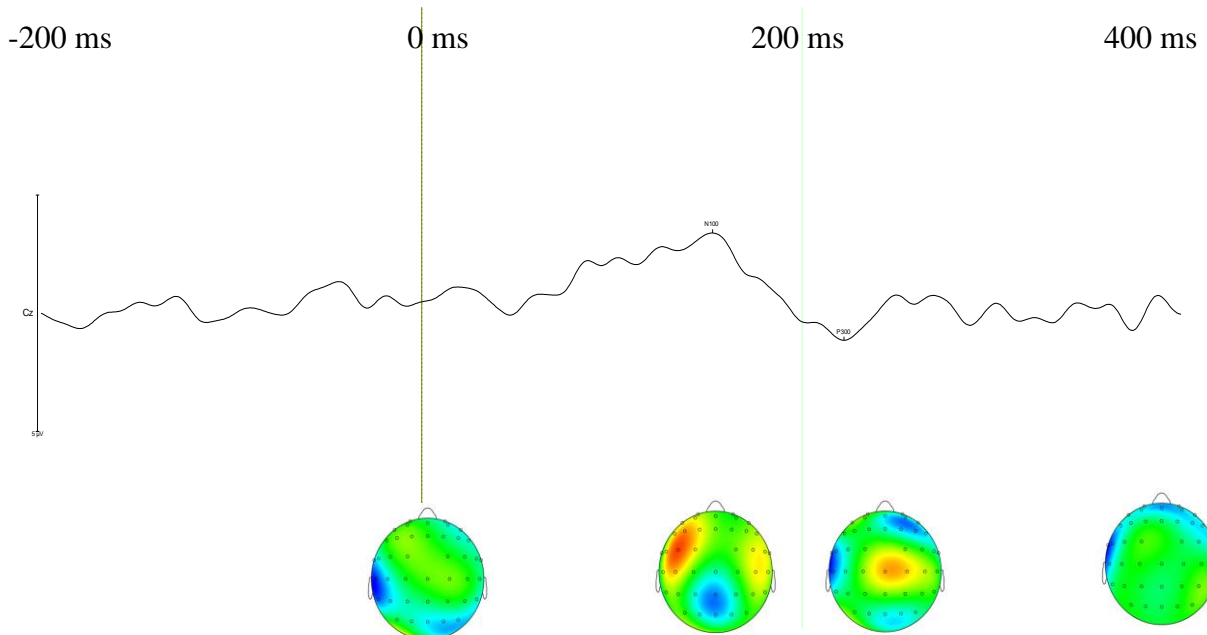

Figure 42 Subject 7

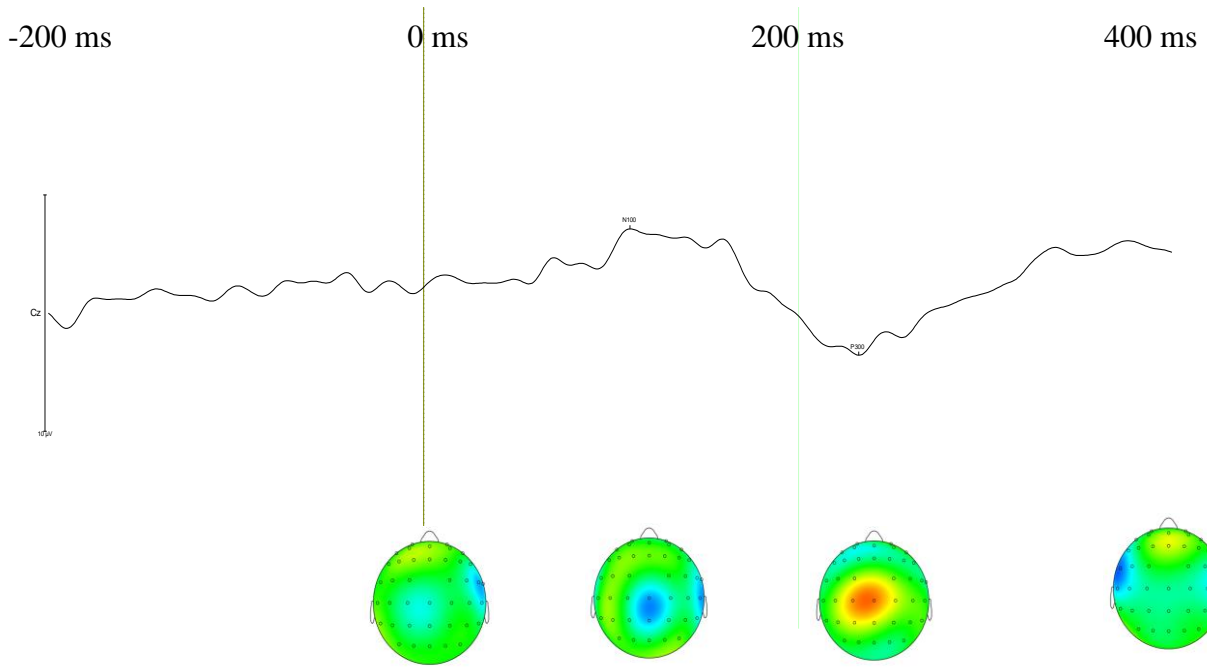

Figure 43 Subject 8

ACL Participants, ACL Leg:

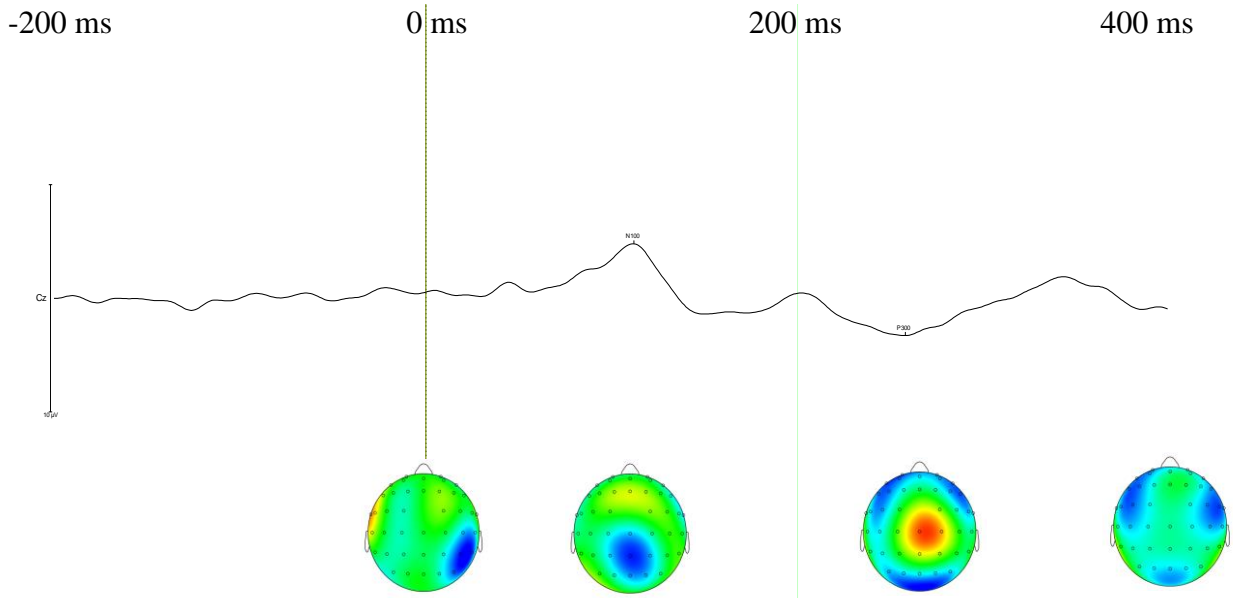

Figure 44 Subject 3

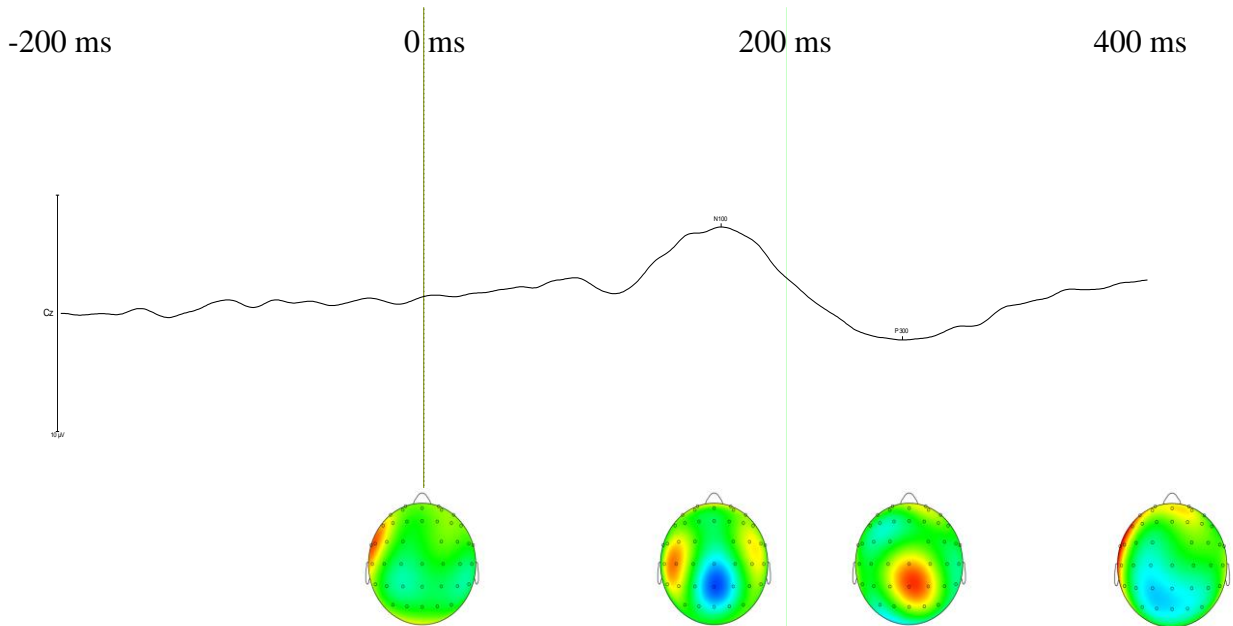

Figure 45 Subject 4

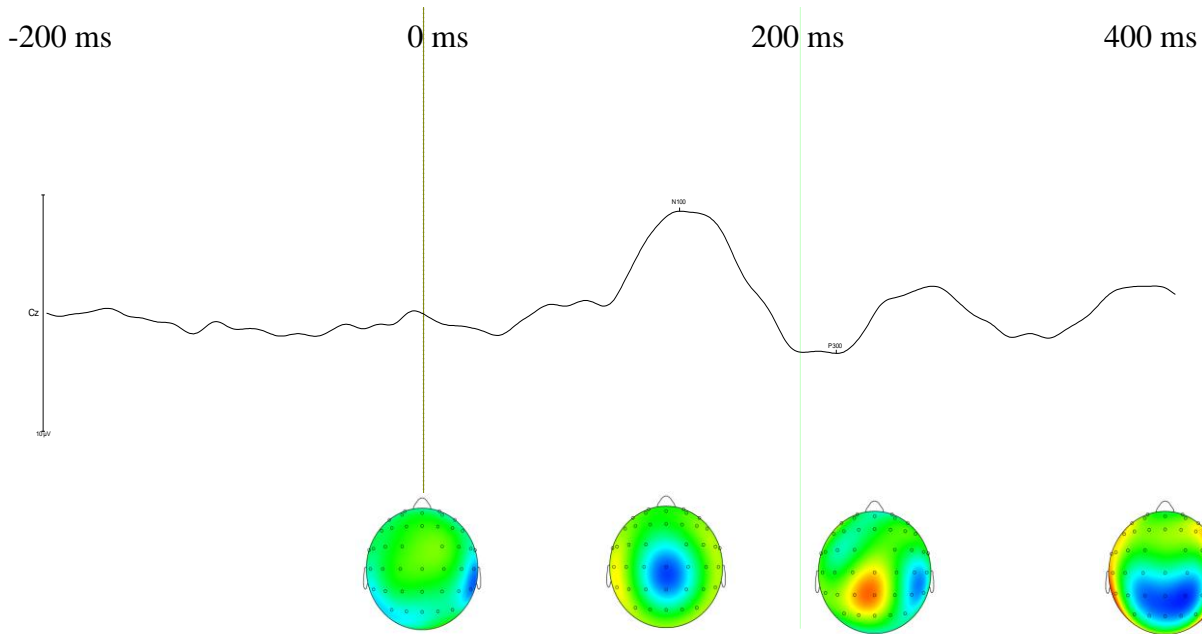

Figure 46 Subject 5

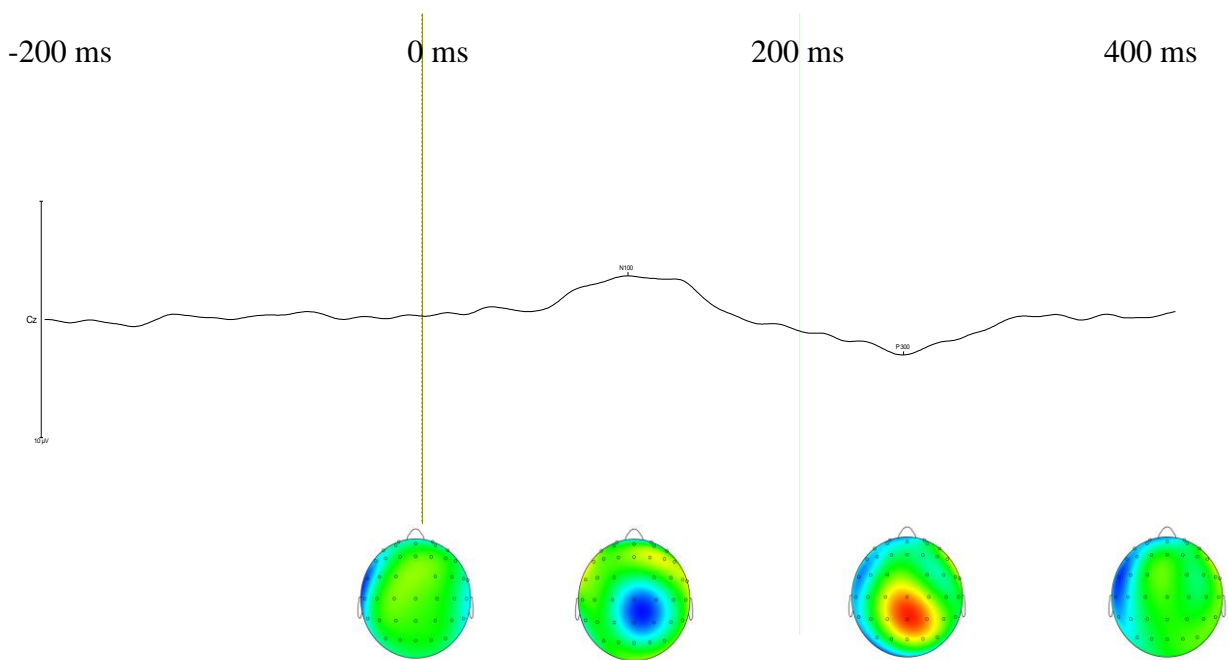

Figure 47 Subject 9

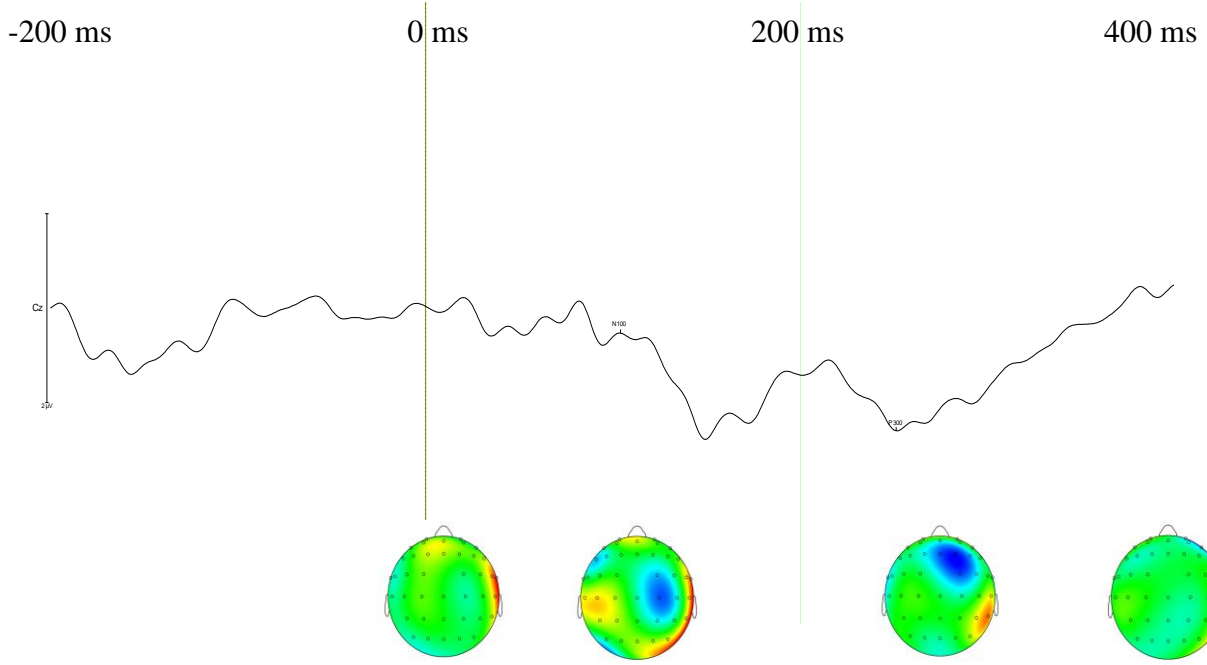

Figure 48 Subject 10

ACL Participants, Healthy Leg:

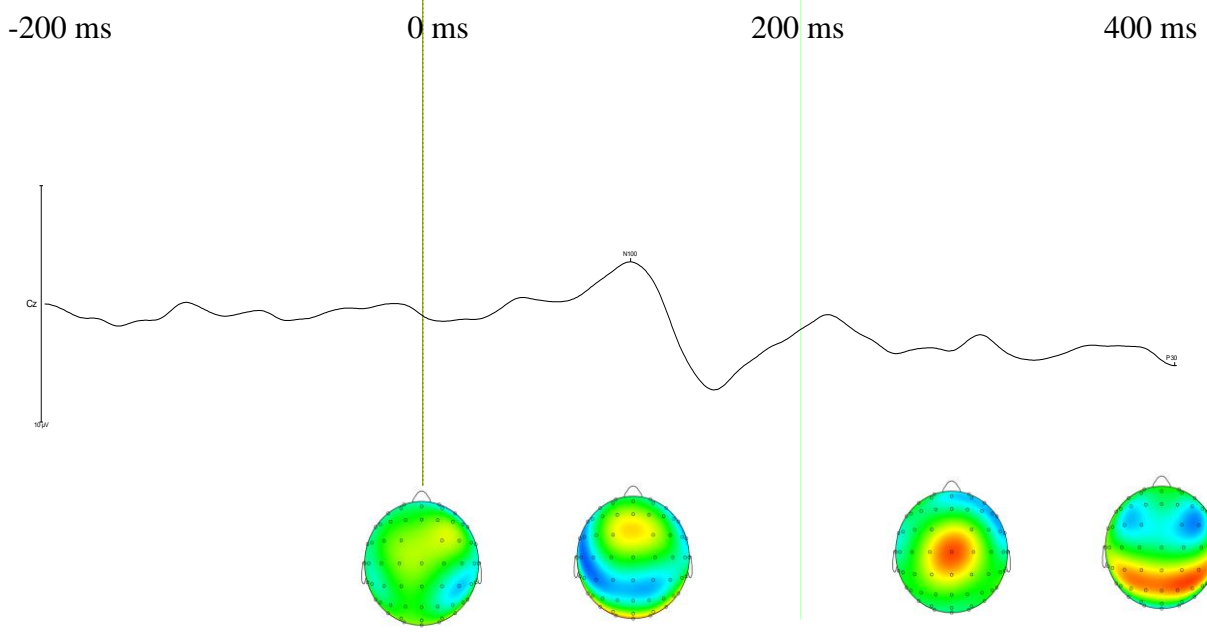

Figure 49 Subject 3

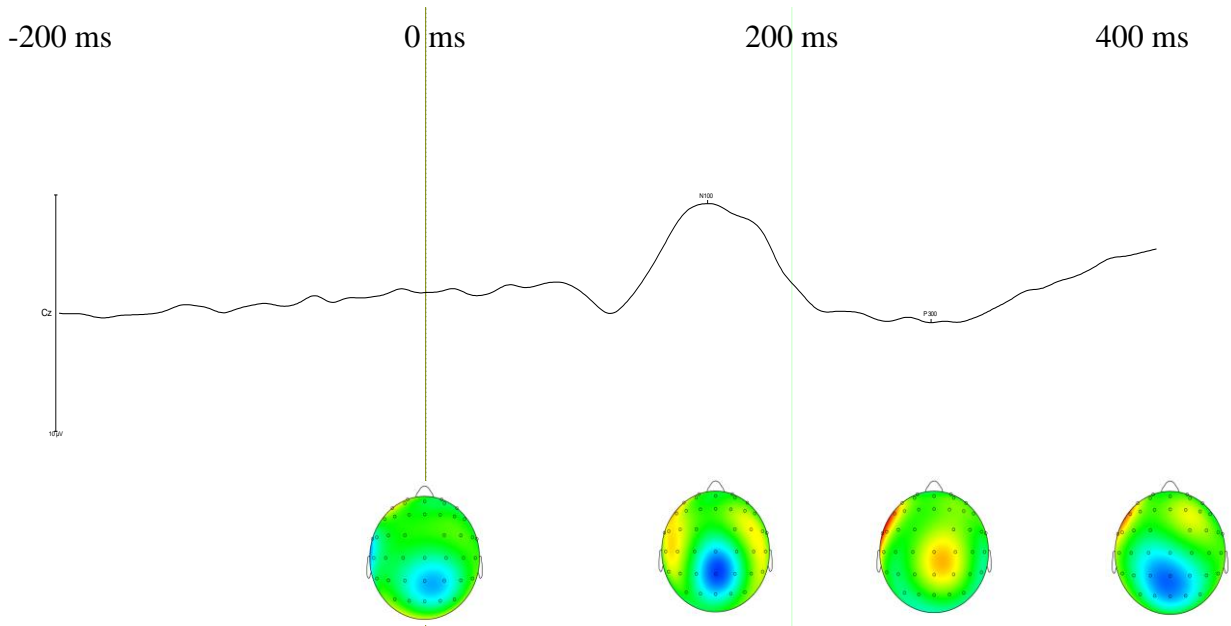

Figure 50 Subject 4

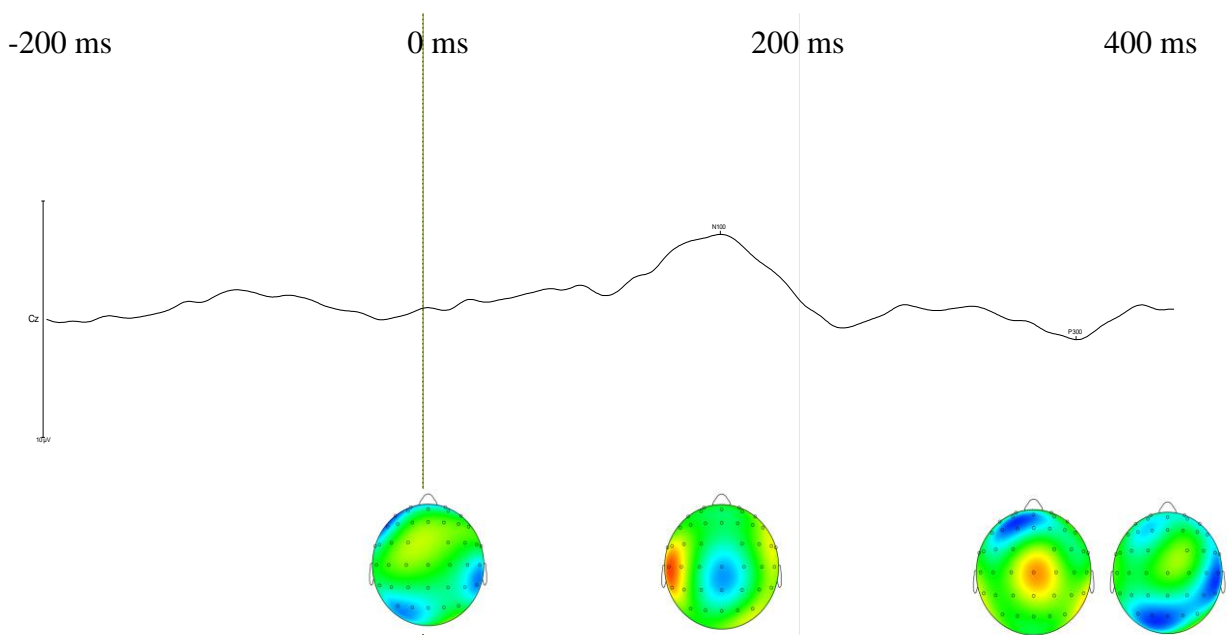

Figure 51 Subject 5

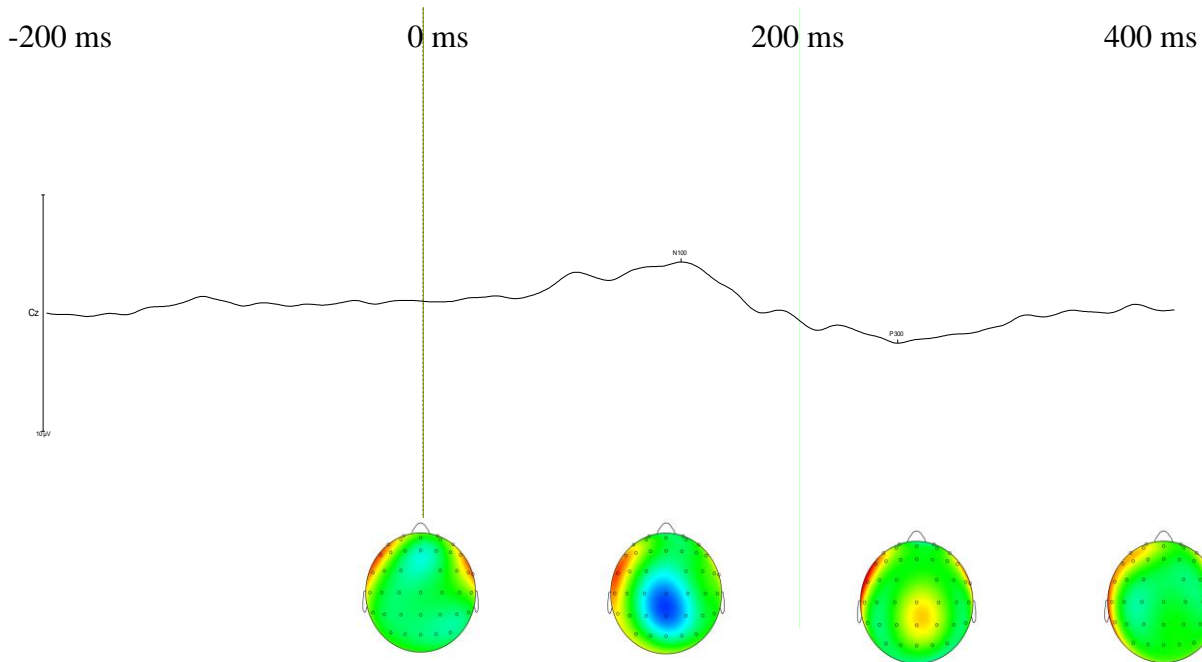

Figure 52 Subject 9

