

# Eye Diagram Optimization based on Design of Experiments (DoE) to Accelerate Industrial Testing of High Speed Links

Andres Viveros-Wacher<sup>1,2</sup> and José E. Rayas-Sánchez<sup>1</sup>

<sup>1</sup>Department of Electronics, Systems, and Informatics, ITESO – The Jesuit University of Guadalajara, Tlaquepaque, Jalisco, 45604 Mexico

<sup>2</sup>Intel Corp. Zapopan, Jalisco, 45019 Mexico ([andres.viveros.wacher@intel.com](mailto:andres.viveros.wacher@intel.com))

**Abstract** — Higher data rates in high speed input/output (HSIO) links demand more equalization (EQ) complexity, leading to an ever larger number of possible combinations of EQ settings. Finding the optimal set of EQ parameters through exhaustive methods is prohibitive given the time-to-market requirements. This paper presents a methodology to design a statistically sufficient set of experiments for optimizing the receiver eye diagram of a HSIO link while greatly reducing the overall testing time. Our methodology is illustrated by a 5-Gbps HSIO link comprised of a Tx, a channel (including packages, vias, PCB traces, connectors and a crosstalk aggressor) and an Rx.

**Index Terms** — central composite design, DoE, equalization, high speed I/O, optimization, response surface model.

## I. INTRODUCTION

Modern high speed input/output (HSIO) links use several stages of EQ circuitry to cancel typical noise impairments and other non-idealities usually encountered on a transmitter-to-receiver interconnect, such as attenuation, dispersion, reflection and inter-symbol interference (ISI), among others. Each EQ stage has design parameters that need to be tuned for optimal performance [1,2]. With a large number of design parameters, or factors, it is no longer feasible to carry out typical experimental strategies such as “one factor at a time”, where a baseline for all factors is selected and then each factor is successively swept. Furthermore, these type of strategies mask any possible interaction between factors.

Another approach is to run a complete enumeration set of experiments, also known as full factorial, where all parameters are varied altogether. In a factorial design with  $k$  factors and  $n$  predefined levels for each factor, the number of required observations or experimental runs is  $n^k$  [3], which is still very time-consuming and may in turn have an impact on the competitiveness of a product.

In this paper, design of experiments (DoE) techniques are exploited to establish a very reduced and reliable set of experiments to efficiently find the optimal equalization parameter values that maximize the eye opening of a realistic HSIO link. We employ a straightforward figure of merit, directly obtained from simulations, to guide the optimization process. We test our methodology by considering a 5-Gbps HSIO link comprised of a transmitter (Tx), a channel and a receiver (Rx). The channel models a real interconnection that includes packages, vias, PCB traces, a connector and a crosstalk aggressor. The entire system is implemented in Keysight ADS.

## II. EQUALIZATION TECHNIQUES

Several undesired effects exist within a HSIO link: Tx jitter, channel loss, interconnect discontinuities, ISI, EM interference, and even noise sources within the Rx circuitry. Correct reception depends on the ability of the Rx to decode incoming data in spite of these undesired effects. In order to guarantee proper link functionality, equalization techniques are used.

### A. Transmitter Equalization (Tx EQ)

Equalization on the transmitter side compensates loss by amplifying high frequency components (also known as pre-emphasis) and attenuating low frequency ones (referred as de-emphasis). Tx EQ is usually carried out by implementing a finite impulse response (FIR) filter [5]. When the series of bits travels through a lossy channel and arrive to the Rx, the forced distortions caused by the Tx EQ on the signals disappear, leaving the received signal shape closer to what was initially intended for transmission.

### B. Receiver Equalization (Rx EQ)

Different Rx EQ techniques have been proposed in digital and analog domains, in linear and non-linear manners and with feed-forward and feedback topologies [6]. The two most common Rx EQ techniques are the continuous time linear equalizer (CTLE) and the decision feedback equalizer (DFE). The main purpose of CTLE is to counteract the channel loss and open the eye by amplifying signals near the Nyquist frequency. Even though CTLE provides a great means to better sample the incoming data, it is still susceptible to noise, given that it also amplifies unwanted signals at high frequency. A DFE is a non-linear EQ technique used to cancel post-cursor ISI from the present bit by using previously received bits. In this work we implemented both a CTLE and a DFE in our simulation model.

## III. HSIO EYE DIAGRAMS

A HSIO link eye diagram is the superposition of several bits into a single time-domain graph [4]. Eye diagrams help to determine the correctness of the Tx signaling, as well as the ability of a Rx to understand incoming data after passing through the physical channel. When the sampling point (both in time and voltage scales) of a receiver is positioned at the center of the eye, by increasing both the eye width,  $e_w$ , and the eye

height,  $e_h$ , the probability of data transmission errors decreases. We calculate the eye diagram area,  $e_A$ , as

$$e_A = e_w e_h \quad (1)$$

and use (1) as a figure of merit in the optimization process to quantify the eye opening.

#### IV. DESIGN OF EXPERIMENTS METHODOLOGY

The DoE methods used in this paper employ response surface models (RSM). We start by developing a first order RSM using a fractional factorial design. A fractional factorial design with two levels for each factor is expressed as  $2^{k-p}$ , where  $k$  is the number of factors under study and  $p$  describes the size of the fraction, given by  $2^{-p}$  [3]. Here we exploit the confounding technique, where the information of certain effects is indistinguishable or confounded with other effects.

Once a first order RSM (in DoE terminology) is obtained, we use it to determine the improvement trajectory, which points to the optimal region. We first calculate the gradient of the objective function starting from a given point, usually being an already tested point. The size of the step to take during each evaluation is proportional to the regression coefficients of the first order model. A maximum has been found when there is no increase on the response.

Finally, we use a central composite design (CCD), to find second order effects to determine the optimal point of the system under study [7]. Here we consider: 1) a  $2^k$  factorial design (or alternatively, a fractional factorial design with resolution  $I$ ) with  $n_F$  runs, where  $n_F$  is the number of fractional runs, 2)  $2k$  axial or star runs and 3)  $n_C$  runs at the center point, where  $3 \leq n_C \leq 5$  for better error estimation.

The plan of action pursued is comprised of three main steps: 1) perform a fractional factorial design to find the most significant variables; 2) perform an initial optimization using the steepest ascent method, and 3) use a CCD to improve the model and maximize the area of the eye diagram.

#### V. HSIO LINK AND EQ VARIABLES

The case under study is a 5-Gbps HSIO link comprised of a Tx, a channel and an Rx. The channel is acting as a real interconnection including packages, vias, PCB traces, a

connector and a crosstalk aggressor. The entire system is modeled and simulated using Keysight ADS [8], and is shown in Fig 1.

Noise factors are also included in the system; two Tx noise sources are used: random jitter with an amplitude of 7 mUI, and periodic jitter with 30 ps of amplitude at 20 MHz. A crosstalk aggressor is included with a random jitter of 10 mUI of amplitude and a 50 ps periodic jitter at 20 MHz. Also, the PCB trace lengths are selected to emulate a long-channel topology commonly used in server applications.

Each part of the system introduces certain kinds of undesired effects. In order for the system to work optimally, EQ techniques are used. On the Tx side, de-emphasis is applied, while on the Rx side, a CTLE with one zero and one pole and a 4-tap DFE are employed. Thus, in total there are seven EQ variables to be used in this study case for maximizing the Rx eye. The outputs of the system are the eye width and eye height obtained from the simulation results, which are combined using (1) to calculate the eye area.

#### VI. OPTIMIZATION PROCEDURE AND RESULTS

Given that we have 7 EQ variables, a  $2^{7-IV}$  fractional factorial design is selected for the first step of the plan of action. By employing this design, only 32 runs are needed, whereas a full factorial requires 128 runs. The design generators chosen are  $x_6 = x_1 x_2 x_3 x_4$  and  $x_7 = x_1 x_2 x_4 x_5$ . Table I presents the factor to variable mapping, along with the +1 and -1 level coding for each factor.

TABLE I  
VARIABLES AND LEVELS FOR THE EQ FACTORS

Factor	Variable	+1	-1
Tx de-emphasis	$x_1$	1 dB	3 dB
CTLE zero	$x_2$	5 Grad/s	-7 Grad/s
CTLE pole	$x_3$	7 Grad/s	10 Grad/s
DFE Tap 1	$x_4$	0.0005	0.0009
DFE Tap 2	$x_5$	0.0015	0.0020
DFE Tap 3	$x_6$	-0.0015	-0.0020
DFE Tap 4	$x_7$	-0.0020	-0.0025

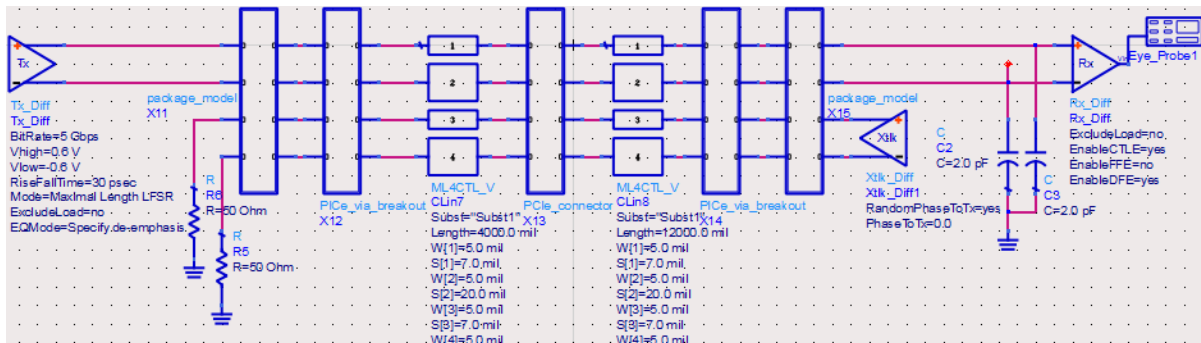

Fig 1. ADS model of the 5-Gbps HSIO link: Tx, channel (including packages, vias, PCB traces, connectors and a crosstalk aggressor) and Rx.

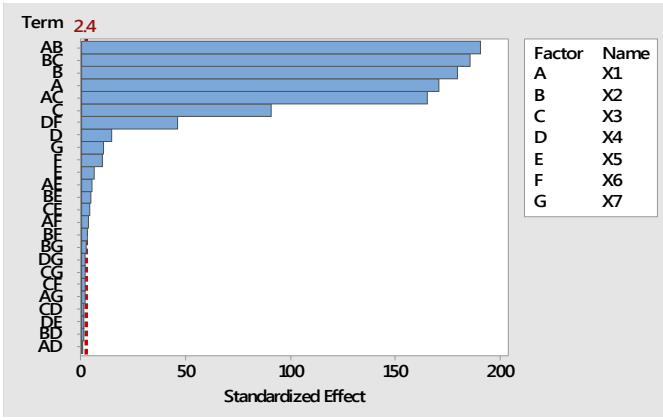

Fig 2. Pareto chart from the fractional factorial analysis.

Fig. 2 depicts the Pareto chart resulting from the fractional factorial design. Even though it shows that all factors and most of the two-level interactions are significant, it is clearly seen that  $x_1$ ,  $x_2$  and  $x_3$ , along with the two-level interactions between them, are the most significant. Therefore, those three factors are chosen for the next step. In order to better maximize the output, the regression model was evaluated with all combinations for the other four factors, and based on the maximum response obtained, their values were selected as follows:  $x_4$  in (-) level,  $x_5$  in (+) level,  $x_6$  in (-) level and  $x_7$  in (-) level. The resulting first-order RSM (in DoE terminology) is

$$e_A(x) = 10048 - 130.7x_1 + 135.6x_2 - 193.3x_3 + 1019x_1x_2 - 637.5x_1x_3 + 843.2x_2x_3 - 85.6x_1x_2x_3 \quad (2)$$

Following the steepest ascent methodology, the gradient of (2) was calculated, obtaining the relative effects of each variable:  $b_{x_1} = -165.2$ ,  $b_{x_2} = 1912.2$  and  $b_{x_3} = -73.2$ . Given that  $b_{x_2}$  presents the largest value,  $x_2$  is selected to dictate the step size for the following experiments. Results for the steepest ascent execution are shown in Fig. 3. As it can be seen, the values corresponding to the 5th experimental run provide the maximum eye area. These values are selected as the center point for the CCD. The second order RSM obtained with the CCD is

$$e_A(x) = 11511 - 104.5x_1 + 262x_2 - 118.8x_3 - 445.7x_1^2 - 383.6x_3^2 + 1018.8x_1x_2 - 637.5x_1x_3 + 843.2x_2x_3 \quad (3)$$

The maximum eye diagram area of the 5-Gbps HSIO link is found by maximizing (3) in closed form. The full system was simulated using the optimal EQ values. Results of this simulation are depicted in Fig. 4, along with the initial eye for comparison purposes. The measured eye area with the optimal settings increased by 173% with respect to that one using the

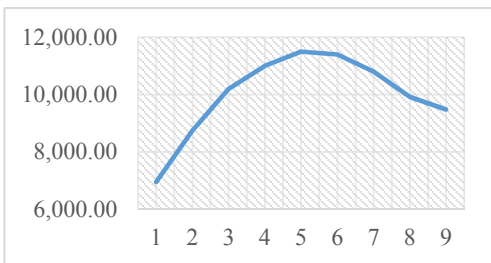

Fig 3. Sequential results for the steepest ascent execution.

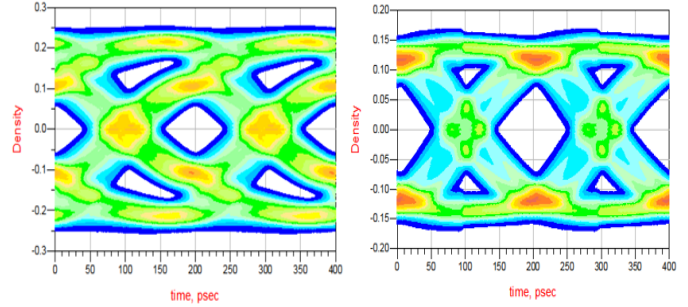

Fig 4. Eye diagram before and after optimization.

original EQ values. Furthermore, the total number of simulations to arrive at the optimal point were 61, which is barely 47% of the number of simulations required to run a full factorial design.

## VII. CONCLUSION

A DOE-based methodology was proposed as a powerful statistical tool to efficiently find the optimal performance of a HSIO link. With the use of a fractional factorial design, the most significant EQ variables were identified with respect to the resulting Rx eye area simulated. An initial and robust procedure was used to find the optimal region of operation, and by using the CCD, a second order model of the system was found in that region, which is used to find in closed form the optimal EQ values to obtain the maximum eye area under the specified conditions of operation.

## ACKNOWLEDGEMENT

This work was supported in part by CONACYT (*Consejo Nacional de Ciencia y Tecnología*, Mexican Government) through a scholarship granted to A. Viveros Wachter.

## REFERENCES

- [1] J. Liu and X. Lin, "Equalization in high-speed communication systems", *IEEE Circuits and Systems Magazine*, vol. 4, no. 2, pp. 4-17, Sep 2004.
- [2] J. Chen, Y. Gu and K. K. Parhi, "Novel FEXT cancellation and equalization for high speed ethernet transmission", *IEEE Trans. on Circuits and Systems*, vol. 56, no. 6, pp. 1272-1285, June 2009.
- [3] D. C. Montgomery, *Design and Analysis of Experiments*, New York, NY: Limusa Wiley, 2014.
- [4] J. Moreira and H. Werkmann, *An Engineer's Guide to Automated Testing of High-Speed Interfaces*, Norwood, MA: Artech House, 2010.
- [5] H. Zhang, S. Krooswyk and J. Ou, *High Speed Digital Design, Design of High Speed Interconnects and Signaling*, California, USA: Morgan Kaufmann, 2015.
- [6] Y. Fan and Z. Zilic, *Accelerating Test, Validation and Debug of High Speed Serial Interfaces*, New York, NY: Springer, 2011.
- [7] G. E. P. Box, J. S. Hunter, and W. G. Hunter, *Statistics for Experimenters: Design, Innovation and Discovery*, Hoboken, NJ: Wiley, 2005.
- [8] Advanced Design Systems (ADS) ver. 2016.01, Keysight Technologies, 1400 Fountaingrove Parkway, Santa Rosa, CA.