

## IOP Conference Series: Materials Science and Engineering

---

PAPER • OPEN ACCESS

# Design improvements for increasing lifetime of single-shot coils applied at rotating workpieces

To cite this article: S Schubotz and B Nacke 2018 *IOP Conf. Ser.: Mater. Sci. Eng.* **424** 012071

View the [article online](#) for updates and enhancements.



**IOP | ebooks™**

Bringing you innovative digital publishing with leading voices to create your essential collection of books in STEM research.

Start exploring the collection - download the first chapter of every title for free.

## Design improvements for increasing lifetime of single-shot coils applied at rotating workpieces

S. Schubotz<sup>1</sup>, B. Nacke<sup>2</sup>

<sup>1</sup> EFD Induction GmbH, Lehener Str. 91, 79106 Freiburg im Breisgau, Germany

<sup>2</sup> Institute of Electrotechnology, Leibniz Universität Hannover, Wilhelm-Busch-Str. 4, 30167 Hannover, Germany

Corresponding author: [Stefan.Schubotz@efd-induction.com](mailto:Stefan.Schubotz@efd-induction.com)

### Abstract

In the industry, induction hardening of rotationally symmetrical workpieces by a single-shot process is a widespread method. Due to only partial superimposition of the workpiece areas to be heated by the coil, high power densities are often needed there. These lead to local hot spots, amounting to an intensive material stress and often result in a short lifetime of the inductor. In this paper, some numerically investigated models will be presented, revealing approaches, how to reduce mechanical stress in the single-shot coil and thus, enabling an increase of service life.

**Key words :** induction hardening, single-shot-coil, numerical simulation, thermal fatigue

### Introduction

Induction hardening of rotationally symmetrical workpieces is usually carried out step by step with a ring coil in a scanning process or at once by a single-shot coil. In the second case, the inductor consists of two long conductors (main leads) and two bridges (Fig. 1). Since the inductor covers only a part of the workpiece in the axial direction (Fig. 2), the entire workpiece zone to be hardened is heated due to rotation almost simultaneously. For this purpose, high power densities are required in the inductor which lead to an inhomogeneous heat source distribution due to electromagnetic effects. After consideration of fluid dynamic behaviour, the resulting temperature field in the coil shows a comparably uneven distribution. At locations of high temperatures, the copper tries to expand but is constrained by colder material. In this way, large tensile and compressive stresses occur in the copper due to high temperature differences. In the usual case of cyclic usage of the hardening inductor, the stresses promote the formation of cracks and these can lead, in long term, to material fatigue and thus to coil failure. In particular, cracks often occur at the workpiece-facing sides of the connection between main conductor and bridge (see Fig. 3). As there is a graphical correlation between lifetime and stress amplitude by Wöhler curves, some approaches for changing the design with the aim to reduce the maximum load and thus, to increase coil lifetime are presented in this paper.

### Approach

After determining the heat sources based on the electromagnetic field distribution in the inductor, a determination of the temperature field has been accomplished, taking into account the turbulent flow in the coil. Here, the LES (Large Eddy Simulation) model has proven to be very suitable in experimental comparison. Afterwards, the mechanical stresses in the coil are calculated based on the temperature distribution. All simulations are done with the commercial tool ANSYS. For calculating the equivalent stress  $\sigma_E$  in each point of the model, the stress intensity is determined according to the shear stress hypothesis of Tresca, which is depending on the three principal stresses  $\sigma_1$ ,  $\sigma_2$  und  $\sigma_3$  as follows:

$$\sigma_E = \max(|\sigma_1 - \sigma_2|, |\sigma_2 - \sigma_3|, |\sigma_3 - \sigma_1|) \quad (1)$$

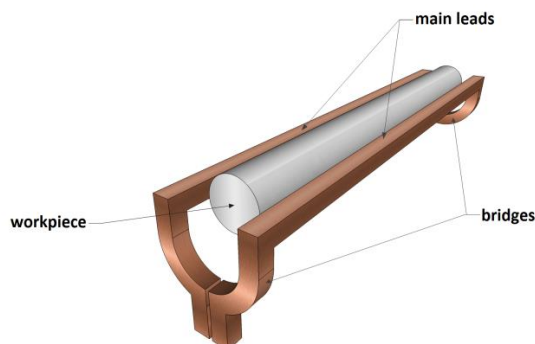

Fig. 1: Single-shot coil with main leads and bridges

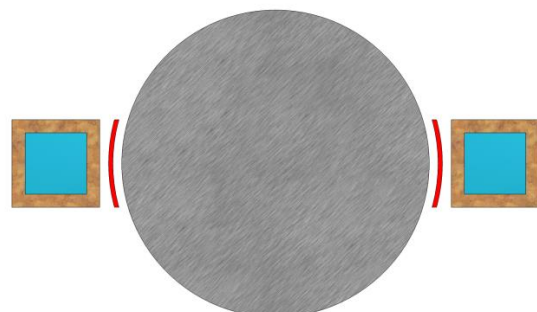

Fig. 2: Cross-section of single-shot coil and workpiece. Red lines expose geometrical superimposing zone



Fig. 3: Crack at the workpiece-facing corner

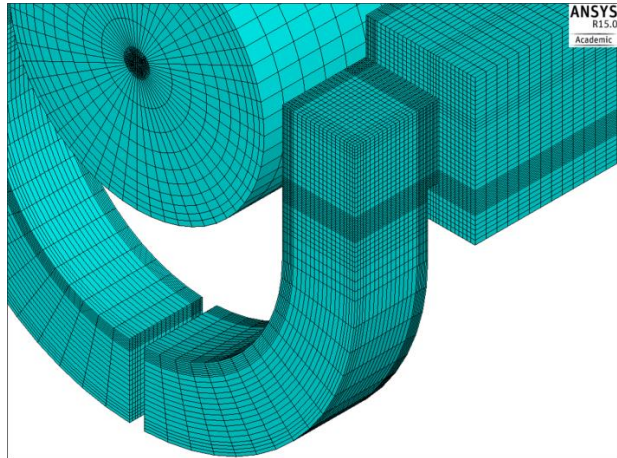

Fig. 4: Mesh of the coil, coolant, concentrators and workpiece

The equivalent stress as a reference value provides information about the load on the inductor and should reveal a conclusion about the success of the coil adjustment.

**Reference-Model**

In this investigation, a single-shot coil with a length of 350 mm is considered for workpieces with a diameter of 35 mm and a coupling distance (space between workpiece-facing sides of main leads and outer diameter of workpiece) of 2.5 mm. A square copper profile is used with an edge length of 10 mm and a wall thickness of 1.5 mm. To improve the efficiency, single-shot coils for hardening applications are usually equipped with field guiding elements (so-called concentrators). Therefore, these components are also taken into account in this simulation, whereas the magneto-dielectric material Fluxtrol100 [1] is placed along the main leads, leaving a small distance to the bridges of 1.5 mm (→ concentrator length: 327 mm). Usually, single-shot inductors are fixed at the sides of the main leads (often by screws or bolts) for stabilization. As a result, the coil can expand in length and height but almost no width change is possible, so the coupling distance remains approximately constant. As follows, the mechanical boundary conditions of this model are defined as the widths of the two outer sides of the Fluxtrol are set as fixed. The model with the associated mesh is shown in Fig. 4. As it can be seen, particularly the areas are finely meshed where high power densities have been simulated previously and where also often cracks occurred in practice that have been responsible for coil failure.

In this model, one heating step with a duration of one second, a cooling water throughput of 8 l/min, an electrical current with a frequency of 8.5 kHz and an effective value of about 3200 A is simulated. The power converted into the workpiece is around 105 kW and heats up the part to approximately 255 °C. This is far beyond hardening temperature, but previous results have revealed that the stress in the coil does not change much at further heating steps. The temperature distribution in the coil is shown in Fig. 5. As it can be seen, the highest temperature (about 153 °C) prevails near the corner on the workpiece-facing side between the main conductor and the bridge. Since the water temperatures rises in the coil, the

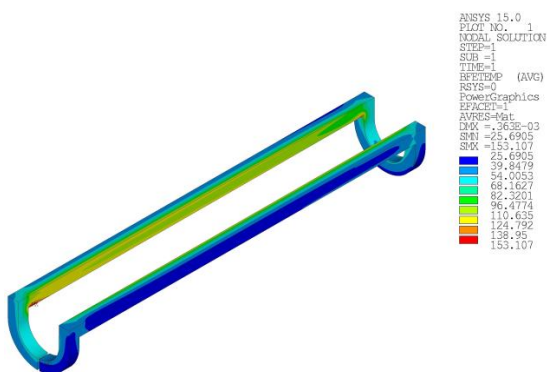

Fig. 5: Temperature distribution in the coil

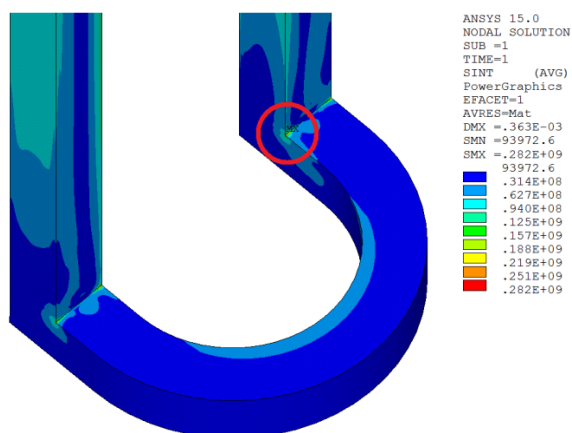

Fig. 6: Stress distribution; peak stress location circled in red

highest temperature is found in the corner before the outlet. The equivalent stress shown in Fig. 6 displays a maximum in a different corner but also at the workpiece facing side between a main lead and a bridge. Generally, the simulation reveals that the equivalent stress is similar in all four corners. Nevertheless, the supplying leads are not fixed in this simulation whereas this also approximates the reality since there is oftentimes no additional mounting. In most cases, only some tape is used to keep the insulation between the supplying leads in place which leaves some space for the copper to thermally expand. In contrast, a lower degree of mobility at the corners near the closed bridge can result in higher stress, although the highest temperature is at a different (last) corner.

### Optimization of coil design

Now, some constructive approaches shall be tested in context of a sensitivity analysis with the aim to reduce the maximum mechanical stress. As part of the geometry modification of the various models, different power densities and temperature fields are generated in the workpiece to be heated. Therefore, the current in the inductor is adjusted in each simulation so that the power converted into the workpiece remains constant. The volume flow is also defined as a constant reference variable, meaning if the coil cross-section changes, an adaptation of the water velocity takes place in each case accordingly. First, it will be examined whether an adjustment of the width or height of the used copper profile leads to an improvement. In addition, due to frequent occurrence of the highest power density in corner regions, using of copper profiles with rounded corners will be tested, whereas it is expected that the power density and thus also the temperature maximum and equivalent stress amplitude at the problematic location reduces. Due to the so-called slot effect, the use of field-guiding elements leads to a displacement of the current to the workpiece-facing side of the main conductors, emerging the generation of hot spots. Therefore, the distance between the lengths of the concentrator-equipped main leads and the bridges of the inductor shall be varied. Since a reduction of the concentrator length would reduce the heating of the workpiece in the end region correspondingly, the inductor length will be increased instead. Finally, another approach is followed with the aim to reduce the current demand greatly. For this purpose, an inductor with four instead of two main conductors is constructed. The current reduction should generate significantly lower power densities in the inductor, whereas a lower maximum stress amplitude is expected.

### Results

In order to establish a relationship between the determined equivalent stress and the lifetime of the coil, the available Wöhler curve from the data sheet of the applied copper (CU-HCP) is used, displaying the fatigue strength for the range of  $10^5$  -  $10^8$  cycles [2]. For this purpose, the approach of [3] is utilized, where it is assumed that the microstructure of the originally soft annealed copper deforms during cyclic use, resulting in a time-averaged stress of zero. Thus, the magnitude of stress in the heating on (+) and off (-) state is the same and the amplitude corresponds to the half of the simulated amplitude. Therefore, at an equivalent stress of 141 MPa ( $= 282 \text{ MPa} / 2$ ), the coil withstands approximately 620.000 alternating loads, leading to an estimated inductor life of about 310.000 cycles.

By reducing the profile height and width, stress can be decreased to 136 MPa and 121 MPa respectively. Basically, shortening the profile height reduces the superimposed area of the workpiece by the coil (red marked zone in Fig. 2), thus, leading to a higher demanded power density in the main conductors. This negative effect is reduced because the coupling distance between the straight profile and the round workpiece is highest at the edges. Although the current is smaller due to a higher inductor impedance, the power density in the critical spot has raised which leads to an increase of the peak temperature by about 9 °C. However, [3] has found out that the difference between peak and average temperature in a 2D coil cross-section has a vital impact on coil-lifetime. A similar circumstance is also observed in this 3D-simulation,

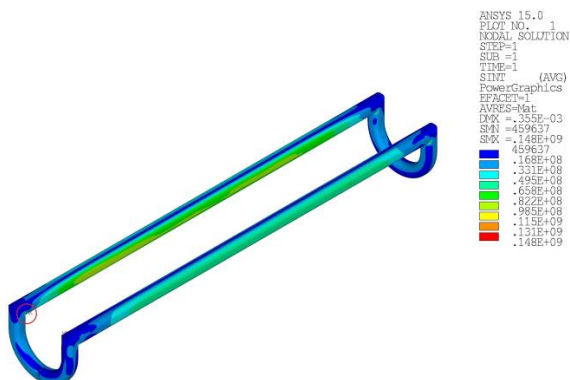

Fig. 7: Stress at a coil with rounded square profile.  
Peak stress location is circled in red

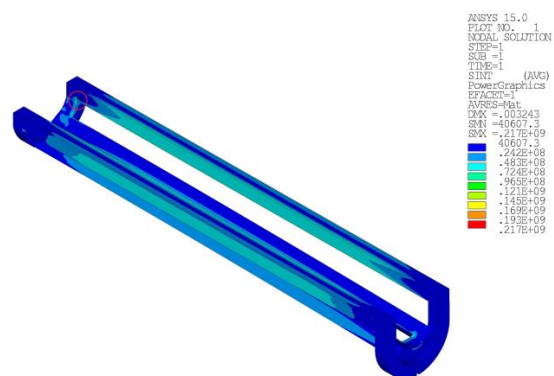

Fig. 8: Coil with four main leads (meander shape)  
Peak stress location is circled in red

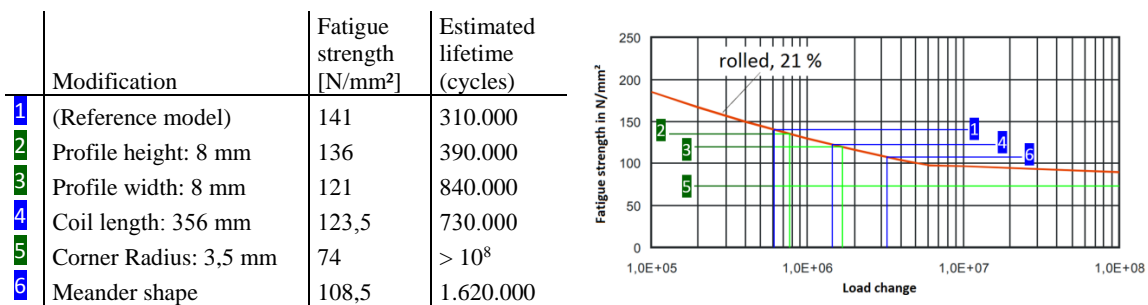

Fig. 9: Simulated fatigue strengths of coil adjustments (left) and correlation to expected load changes (right, [2])

where the temperature of the area around the critical spot is much higher when the profile width is 8 mm, leading to a smaller difference between peak and average temperature. Besides that, assuming a constant volumetric flow, the smaller coil cross-section results in a rising water velocity, thereby improving the heat transfer coefficient which also reduces this temperature difference. The sum of these different effects finally results in a reduction of the stress.

Raising the water speed meaning an increase of the heat transfer coefficient is also a positive consequence when the profile width is reduced. In this case, the peak temperature in the corner decreases by over 5 °C in comparison to the reference model. Another advantage when lowering the width of the cross-section is that due to the narrower copper profile, the magnetic field lines close over a shorter distance and thus, slightly reduce the power loss and finally the power consumption. Therefore, the disadvantage of an increased resistance due to a reduction of the copper cross-section only plays a minor role because of current displacement effects.

The simple approach of increasing the coil length and thus, the distance between the field-guiding elements and the bridge, also has a beneficial impact on the mechanical stresses (141 → 123.5 MPa). Raising the gap by only 3 mm from 1.5 to 4.5 mm has already decreased the load by more than 12 %. An additional increase can further reduce the stresses significantly, but by extending the length of the inductor, the hardening zone is also affected. Therefore, depending on the workpiece, a redesign of the end connections might be necessary.

Applying a copper profile which has the shape of a rounded square with 3.5 mm corner radius leads to a large reduction of the mechanical stresses in the coil (see Fig. 7). As a result, it is possible to influence the problematic zone specifically, since the current distributes across a bigger area, thus reducing the power density in the corner. In this case, the increased inductor impedance and the smaller flow cross-section lead to additional advantages due to reduced power requirement and a higher fluid velocity.

The constructively most complicated approach, using four instead of two main conductors, also has a positive effect on coil lifetime (see Fig. 8). In this case, doubling of the superimposed area between inductor and workpiece at a high coil impedance results in a significantly lower current demand which reveals a great reduction of the power density.

All calculated nominal stress amplitudes of the different simulations are summarized in a table and they are exposed with the associated Wöhler curve in Fig. 9.

## Conclusion

In this paper, the issue of a short lifetime of single-shot coils for rotationally symmetrical workpieces has been presented. Some investigated, constructive approaches have shown that with little effort, thermally induced, mechanical stresses can be reduced significantly. Especially by using of copper profiles with rounded corners, service life can be improved greatly. In comparison, the meander shaped coil does not bring such a big advantage but it creates a lot more manufacturing labour. Besides that, the efficiency of this coil is about 4 % lower, compared to the reference model. Nevertheless, this variant is still an interesting approach if workpieces with a large diameter have to be hardened, resulting in a big necessary surface power density demand in the coil. In this case, if a coil with a rounded profile does not give sufficient service life, one could think of using a meander-shaped coil, maybe also with six or even eight main leads.

In the further course, the exact influences of the design adjustments have to be analysed in the context of parameter studies. Additionally, since the connection between the main conductor and the bridge is oftentimes soldered, there is usually a small radius in the corner between these two components, which influence on coil lifetime shall also be considered. Besides that, electromagnetic forces also put stress on the coil and are therefore to be investigated. Finally designing guidelines have to be defined, allowing the coil manufacturer to build the single-shot inductor according to, whereas this shall result in a long coil life time, even at high power levels.

## References

1. Fluxtrol Inc.: Fluxtrol 100, <https://fluxtrol.com/inc/pdf/Fluxtrol-100-Specs.pdf>
2. Deutsches Kupferinstitut, Cu-HCP-Datenblatt
3. K. Svendsen, Thermal Fatigue in High Current Density Induction Coils, Dissertation (2012)