

The Texas Medical Center Library
DigitalCommons@TMC

UT GSBS Dissertations and Theses (Open Access)

Graduate School of Biomedical Sciences

5-2019

GENETIC COUNSELOR UTILIZATION AND INTERPRETATION OF SOMATIC TUMOR TESTING IN EVALUATION FOR LYNCH SYNDROME

Danielle Williams

Follow this and additional works at: https://digitalcommons.library.tmc.edu/utgsbs_dissertations

 Part of the [Cancer Biology Commons](#), [Genetics Commons](#), and the [Medicine and Health Sciences Commons](#)

Recommended Citation

Williams, Danielle, "GENETIC COUNSELOR UTILIZATION AND INTERPRETATION OF SOMATIC TUMOR TESTING IN EVALUATION FOR LYNCH SYNDROME" (2019). *UT GSBS Dissertations and Theses (Open Access)*. 936.

https://digitalcommons.library.tmc.edu/utgsbs_dissertations/936

This Thesis (MS) is brought to you for free and open access by the Graduate School of Biomedical Sciences at DigitalCommons@TMC. It has been accepted for inclusion in UT GSBS Dissertations and Theses (Open Access) by an authorized administrator of DigitalCommons@TMC. For more information, please contact nha.huynh@library.tmc.edu.

GENETIC COUNSELOR UTILIZATION AND INTERPRETATION OF SOMATIC
TUMOR TESTING IN EVALUATION FOR LYNCH SYNDROME

by

Danielle Rae Williams, B.A.

APPROVED:

Maureen Mork, M.S.
Advisory Professor

Meagan Choates, M.S.

Syed Hashmi, M.D., Ph.D., MPH

Sarah Noblin, M.S.

Eduardo Vilar-Sanchez, M.D., Ph.D.

APPROVED:

Dean, The University of Texas
MD Anderson Cancer Center UTHHealth Graduate School of Biomedical Sciences

GENETIC COUNSELOR UTILIZATION AND INTERPRETATION OF SOMATIC
TUMOR TESTING IN EVALUATION FOR LYNCH SYNDROME

A

THESIS

Presented to the Faculty of

The University of Texas

MD Anderson Cancer Center UTHealth

Graduate School of Biomedical Sciences

in Partial Fulfillment

of the Requirements

for the Degree of

MASTER OF SCIENCE

by

Danielle Rae Williams, B.A.
Houston, Texas

May 2019

Acknowledgments:

I would first like to thank my thesis advisor, Maureen Mork, for her endless support throughout this project. Her guidance and expertise was invaluable to every stage of this research.

I would also like to thank each of my committee members for their assistance and contributions to this research. Their willingness to help and provide their perspective is much appreciated.

Additionally, I am grateful for all the genetic counselors who took the time to complete our survey. This research would have been impossible without their enthusiasm to support this project.

GENETIC COUNSELOR UTILIZATION AND INTERPRETATION OF SOMATIC TUMOR TESTING IN EVALUATION FOR LYNCH SYNDROME

Danielle Rae Williams, B.A.

Advisory Professor: Maureen Mork, M.S.

Lynch syndrome (LS) is a hereditary cancer predisposition syndrome characterized by increased risk for colorectal and uterine cancers. Individuals with pathogenic variants in the mismatch repair (MMR) genes (*MLH1*, *MSH2/EPCAM*, *MSH6*, *PMS2*) are diagnosed with LS and subsequently recommended to proceed with high risk screening protocols to increase prevention and early detection of LS-related cancers. Various tumor studies can help identify those at high risk for LS, but sometimes create uncertainty with discordant screening and germline results, leading to unexplained mismatch repair deficiency (UMMRD). Somatic testing of the MMR genes has created opportunities for resolving UMMRD, thus clarifying LS status and ensuring appropriate cancer surveillance. However, guidelines for such testing are currently limited. The purpose of this study was to examine current and hypothetical ordering practices of cancer genetic counselors for LS evaluation and to investigate participants' interpretation of somatic MMR testing results. Two-hundred eligible participants were recruited through the National Society of Genetic Counselors listserv and answered questions regarding demographics, ordering practices, barriers to somatic MMR testing, theoretical patient scenarios, and need for further guidelines. Statistical analysis was done using Chi-square, Fisher exact, and Wilcoxon rank-sum tests while themes were identified from free-text responses. Most respondents did not include somatic MMR testing in the work-up for LS and did not routinely order this testing, but indicated interest in ordering this in conjunction with germline testing. The gap between preferred testing strategies and current ordering practices for somatic MMR testing may be due to reported laboratory and insurance-related barriers, particularly cost and coordination of tissue specimens. Nearly all individuals endorsed the need for additional guidelines for somatic MMR

testing, which could provide support to reduce barriers, encourage insurance coverage, and allow for appropriate screening recommendations for patients and family members of those with UMMRD.

Table of Contents:

Approval Sheet i

Title Page ii

Acknowledgments iii

Abstract iv

List of Illustrations vii

List of Tables viii

Introduction 1

Methods 3

Results 4

Discussion 15

Appendix 19

Bibliography 29

Vita 32

List of Illustrations:

Figure 1. Perceived barriers by participants to somatic MMR testing9

Figure 2. Scenario pedigrees provided to participants11

List of Tables:

Table 1. Participant demographics	5
Table 2. Description of ordering practices	7
Table 3. Scenario responses	13
Table 4. Free response examples	14

INTRODUCTION

Lynch syndrome (LS), formerly known as hereditary nonpolyposis colorectal cancer (HNPCC), is one of the most prevalent and well-defined hereditary cancer syndromes (Lynch et al., 2015). It is caused by germline heterozygous pathogenic variants in the mismatch repair (MMR) genes (*MSH2*, *MSH6*, *MLH1*, and *PMS2*), as well as *EPCAM*. (Lynch et al., 2015; Tiwari et al., 2016; Pena-Diaz et al., 2015). Individuals with LS have an increased lifetime risk for colorectal and uterine cancers as well as extracolonic cancers of the ovary, renal pelvis, stomach, small bowel, brain, and sebaceous gland compared to the general population (Lynch et al., 2015; Tiwari et al., 2016; Vasen et al., 1999). Individuals with LS tend to have an earlier age of diagnosis and a higher rate of multiple primary cancers than the general population (Lynch et al., 2015; Tiwari et al., 2016; Vasen et al., 1999).

Microsatellite instability (MSI) analysis and immunohistochemistry (IHC) staining are often initial tumor screens used to identify individuals at increased risk for LS (Battaglin et al., 2018; Cohen et al., 2014; Tiwari et al., 2016). MSI analysis determines the mutation status of microsatellite repeats and those with more mutated sequences are deemed MSI-high, which can be an indication of MMR deficiency (Lynch et al., 2015; Pena-Diaz et al., 2015; Tiwari et al., 2016). IHC staining can be used to determine MMR protein status in the tumor; absence of staining in one or more of these proteins raises suspicion for a germline pathogenic variant in one of the MMR genes (Lynch et al., 2015; Pritchard, et al., 2012). *MLH1* promoter hypermethylation and/or *BRAF* somatic mutation analyses also contribute to risk assessment as the presence of either *MLH1* promoter hypermethylation or the V600E mutation in *BRAF* are associated with sporadic MSI-high tumors as opposed to LS (Deng et al., 2004; McGivern et al., 2004).

In addition to *MLH1* promoter hypermethylation and *BRAF* V600E mutations, biallelic (or “double”) somatic MMR mutations can also be responsible for some MMR deficient cancers in the absence of a germline mutation, also known as unexplained mismatch repair deficiency (UMMRD) (Mesenkamp et al., 2014; Sourrouille et al., 2012). UMMRD can be due to undetectable germline pathogenic variants and large rearrangements, somatic mosaicism, false-positive staining, or biallelic

somatic mutations (Haraldsdottir et al., 2014). Individuals with biallelic somatic mutations are considered unlikely to have LS because these cases are either caused by two somatic mutations or one somatic mutation combined with somatic loss of heterozygosity, thus resulting in MMR deficiency in the tumor (Buecher et al., 2018; Mesenkamp et al., 2014). Biallelic somatic MMR mutations may explain up to 52% of UMMRD, helping to inform LS status and potentially sparing patients and their families from intensive cancer screenings (Mensenkamp et al., 2014; Sourrouille et al., 2012).

Biallelic somatic MMR mutations cannot be differentiated from LS using tumor pathology, MSI analysis, or IHC staining, so challenges arise when UMMRD occurs (Haraldsdottir et al., 2014; Hemminger et al., 2018). However, next-generation sequencing has led to more frequent utilization of tumor profiling to pinpoint somatic mutations (Hamepl et al., 2018; Pritchard et al., 2012; Varga et al., 2015) and can be applied to LS tumors as an additional risk assessment tool.

Even though there are opportunities to utilize somatic testing in the evaluation of LS, the corresponding guidelines have not caught up to the available technology. There is currently no consensus about the LS status of individuals with UMMRD (Batte, et al, 2013) and, somatic MMR testing does not explain all MSI-high tumors without a germline mutation. This creates dilemmas for genetic counselors and physicians in providing screening recommendations. Only 5.2% of genetic counselors have reported being “completely prepared” and 67% reported being “somewhat prepared” to handle comprehensive tumor profiling results (Goedde et al., 2017). However, it is still unknown how this applies to LS somatic MMR testing. The National Comprehensive Cancer Network (NCCN) current guidelines (NCCN, Version 1.2018) contain limited recommendations for the interpretation of somatic MMR testing for LS in a footnote (LS-A 4 of 5; footnote d). The footnote discusses biallelic somatic MMR mutations as a possible explanation for UMMRD and suggests genetic consultation for complex results without guidelines for interpreting complex results. This minimal guidance leaves room for inconsistency among genetic counseling practices.

The availability of somatic MMR testing in evaluation of LS has great implications for patient management, but its use among cancer genetic counselors has not been studied. Thus, we aimed to

investigate current somatic MMR ordering practices, and consistency in risk assessments by cancer genetic counselors to identify gaps in available recommendations and assess the need for more comprehensive guidelines.

METHODS

This study was approved by the University of Texas Health Science Center Institutional Review Board, governed by the Committee for the Protection of Human Subjects (HSC-MS-18-0442).

Participants and Procedures:

Participants were recruited to this cross-sectional study through the National Society of Genetic Counselors (NSGC) listserv between September 2018 and November 2018. A survey link was sent via email to all NSGC registered members, followed by a reminder, and posted to the Cancer Special Interest Group (SIG) discussion board. Practicing board-certified or board-eligible clinical genetic counselors, who actively see patients in the cancer setting, were eligible to participate in the study. The survey was anonymous and remained open for 8 weeks. Informed consent was obtained prior to proceeding to the questionnaire portion of the survey. Participants were excluded from the study if they were employed by a diagnostic laboratory, did not meet the eligibility criteria, or only completed the demographic section of the survey.

Instrumentation:

Qualtrics (Qualtrics, Provo, UT) was used to administer the survey and collect data. Participants who consented to the study were asked eligibility criteria, demographic information, current ordering practices, scenarios involving hypothetical patients, and views on further guidelines. The subjects were given an opportunity for free-text comments at the end of the survey. The question format varied, with the vast majority (45/53 content questions) being multiple choice. Subjects could exit the survey at any

point, and subjects were not required to answer every question. The study questionnaire was created by the authors and was not externally validated (Appendix A).

Data Analysis:

Data was analyzed using STATA (version 13.1, College Station, TX) with a level of significance of $p \leq 0.05$. Descriptive statistics were completed including medians for continuous variables and frequencies and percentages for categorical variables. Demographic responses were compared to the results of the NSGC 2018 Professional Status Survey (PSS) using proportion tests. Chi-square, Fisher exact, and Wilcoxon rank-sum tests were used to compare differences between responses for selected questions and estimate the significance. Free responses were analyzed to identify themes within participant comments, with the flexibility to code multiple themes for one response.

RESULTS

Demographics:

Following the survey closure, there were 224 total responses. Thirteen responses were excluded due to ineligibility, while 11 did not meet the minimum completeness requirement and were also excluded. The remaining 200 respondents were included in the study. Since participants were not required to answer every question, the total number of responses varied across questions. Demographic information is reported in Table 1. The majority of participants worked full-time (98%, $n = 195/200$), had less than six years of experience in a cancer setting (75%, $n = 150/200$), and did not practice additional specialties (69%, $n = 137/200$). Most individuals (86%, $n = 171/200$) worked with other genetic counselors. Just over half (52%, $n = 103/198$) of respondents practiced in a state with licensure. The median number of colorectal cancer cases assessed per month (personal or family history) was five (Interquartile range: 4-10) and the median number of uterine cancer cases assessed per month (personal or family history) was three (Interquartile range: 2-5). Demographics were compared to the 2018 NSGC PSS and did not reveal any statistically significant differences for licensure status or regions 1-5. Region

6 was underrepresented in our responses compared to the PSS. While different work setting options were presented in the two surveys, there were no statistically significant differences for the proportion of individuals at a university medical center or in a private medical facility. However, there were a higher proportion of genetic counselors who worked at a public medical facility in our cohort compared to the PSS.

Table 1. Participant demographics

	All (n=200) n (%)	Academic Setting		p-value	Sole GC		p-value
		Yes (n=110)	No (n=90)		Yes (n=29)	No (n=171)	
Experience in Cancer				0.562			0.697
0-5 years	150 (75)	84 (42)	66 (33)		20 (10)	130	
6-10 years	28 (14)	15 (7.5)	13 (6.5)		6 (3)	22 (11)	
11-15 years	9 (4.5)	6 (3)	3 (1.5)		1 (0.5)	8 (4)	
16-20 years	8 (4)	4 (2)	4 (2)		1 (0.5)	7 (3.5)	
>20 years	5 (2.5)	1 (0.5)	4 (2)		1 (0.5)	4 (2)	
Position Type				0.176			0.154
Full-time (>30 hr/wk)	195 (97.5)	109 (54.5)	86 (43)		27 (13.5)	168 (84)	
Part-time (<30 hr/wk)	5 (2.5)	1 (0.5)	4 (2)		2 (1)	3 (1.5)	
Setting *							
Public	70 (35)	28 (14)	42 (21)	0.002	17 (8.5)	53 (26.5)	0.004
Private	53 (26.5)	13 (6.5)	40 (20)	<0.001	10 (5)	43 (21.5)	0.292
University	83 (41.5)	81 (40.5)	2 (1)	<0.001	0 (0)	83 (41.5)	<0.001
Physician's practice	4 (2)	0 (0)	4 (2)	0.040	2 (1)	2 (1)	0.101
Other	5 (2.5)	1 (0.5)	4 (2)	0.176	0 (0)	5 (2.5)	1.000
Additional Specialties							
Only cancer cases	137 (68.5)	78 (39)	59 (29.5)	0.417	22 (11)	115 (57.5)	0.356
Other specialties*							
General genetics	31 (15.5)	20 (10)	11 (5.5)	0.247	3 (1.5)	28 (14)	0.581
Pediatrics	27 (13.5)	16 (8)	11 (5.5)	0.632	2 (1)	25 (12.5)	0.381
Adult	37 (18.5)	19 (9.5)	18 (9)	0.621	2 (1)	35 (17.5)	0.118
Cardiology	22 (11)	8 (4)	14 (7)	0.063	2 (1)	20 (10)	0.747
Neurogenetics	11 (5.5)	3 (1.5)	8 (4)	0.068	1 (0.5)	10 (5)	1.000
Metabolic	3 (1.5)	2 (1)	1 (0.5)	1.000	0 (0)	3 (1.5)	1.000
Prenatal	23 (11.5)	7 (3.5)	16 (8)	0.012	3 (1.5)	20 (10)	1.000
Other	7 (3.5)	4 (2)	3 (1.5)	1.000	1 (0.5)	6 (3)	1.000
Cancer Subspecialty							
None	184 (92)	97 (48.5)	87 (43.5)	0.035	27	157	1.000
Subspecialty *	16 (8)						
Breast	5 (2.5)	4 (2)	1 (0.5)	0.381	1 (0.5)	4 (2)	0.547
Gynecological	5 (2.5)	3 (1.5)	2 (1)	1.000	2 (1)	3 (1.5)	0.154
Gastrointestinal	9 (4.5)	7 (3.5)	2 (1)	0.190	2 (1)	7 (3.5)	0.621
Genitourinary	2 (1)	1 (0.5)	1 (0.5)	1.000	1 (0.5)	1 (0.5)	0.27
Pediatric	3 (1.5)	2 (1)	1 (0.5)	1.000	0 (0)	3 (1.5)	1.000

Other	3 (1.5)	3 (1.5)	0 (0)	0.254	0 (0)	3 (1.5)	1.000
NSGC Region **				0.099			0.338
Region 1	16 (8)	14 (7)	2 (1)		0 (0)	16 (8)	
Region 2	48 (24)	24 (12)	24 (12)		9 (4.5)	39 (19.5)	
Region 3	21 (11)	10 (5)	11 (5.5)		3 (1.5)	19 (9.5)	
Region 4	62 (31)	34 (17)	28 (14)		12 (6)	50 (25)	
Region 5	32 (16)	19 (9.5)	13 (6.5)		3 (1.5)	29 (14.5)	
Region 6	20 (10)	9 (4.5)	11 (5.5)		2 (1)	18 (9)	

* Subcategories are not mutually exclusive

** Region 1 (CT, MA, ME, NH, RI, VT, CN Maritime Provinces)

Region 2 (DC, DE, MD, NJ, NY, PA, VA, WV, PR, VI Quebec)

Region 3 (AL, FL, GA, KY, LA, MS, NC, SC, TN)

Region 4 (AR, IA, IL, IN, KS, MI, MN, MO, ND, NE, OH, OK, SD, WI, Ontario)

Region 5 (AZ, CO, MT, NM, TX, UT, WY, Alberta, Manitoba, Sask)

Region 6 (AK, CA, HI, ID, NV, OR, WA, British Columbia)

Ordering Practices:

Participants were asked about their institution's ordering practices for IHC, MSI, and somatic MMR testing in the work-up for LS. These responses are reported in Table 2. Most individuals (91%, n = 181/200) reported their institution included IHC and the majority of those (85%, n = 154/181) used an in-house laboratory. Less than half (44%, n = 87/199) worked at an institution that included MSI in the LS work-up, with the majority of these (74%, n = 64/87) performed at an in-house laboratory. Genetic counselors who worked in an academic setting were more likely to have an institution that used an in-house laboratory for both IHC ($p = 0.003$) and MSI ($p < 0.0001$) testing than those not at an academic institution. Less than a third (29%, n = 57/199) of respondents reported their institution included somatic MMR testing in evaluation of LS, with the majority (66%, n = 37/56) performed at an external laboratory. Of those who had experience ordering somatic MMR testing, less than a quarter (23%, n = 28/124) reported "routinely" ordering this testing and half (50%, n = 62/124) reported only using this testing "occasionally" or "rarely".

Table 2. Description of ordering practices

	All (n=200) n (%)	Academic Setting		p- value	Sole GC		p- value
		Yes (n=110)	No (n=90)		Yes (n=29)	No (n=171)	
IHC work-up				0.634			0.646
Included	181 (91)	101 (51)	80 (40)		27 (14)	154 (77)	
Not included	14 (7)	6 (3)	8 (4)		2 (1)	12 (6)	
Unsure	5 (2)	3 (1)	2 (1)		0 (0)	5 (2)	
IHC testing[^]				0.003			0.433
In-house	154 (86)	93 (52)	61 (34)		24 (13)	130 (72)	
Send-out	16 (9)	3 (2)	13 (7)		3 (2)	13 (7)	
Unsure	10 (5)	4 (2)	6 (3)		0 (0)	10 (6)	
MSI work-up				0.185			0.770
Included	87 (44)	54 (27)	33 (17)		12 (6)	75 (37)	
Not included	99 (50)	49 (25)	50 (25)		16 (8)	83 (42)	
Unsure	13 (6)	6 (3)	7 (3)		1 (1)	12 (6)	
MSI testing[^]				<0.001			<0.001
In-house	64 (74)	49 (56)	15 (17)		3 (3)	61 (70)	
Send-out	17 (19)	3 (4)	14 (16)		7 (8)	10 (12)	
Unsure	6 (7)	2 (2)	4 (5)		2 (2)	4 (5)	
MMR work-up				0.867			0.584
Included	57 (29)	32 (16)	25 (13)		7 (3)	50 (25)	
Not included	127 (64)	68 (34)	59 (30)		21 (11)	106 (53)	
Unsure	15 (7)	9 (4)	6 (3)		1 (1)	14 (7)	
MMR testing[^]				0.116			0.803
In-house	15 (27)	12 (21)	3 (5)		1 (2)	14 (25)	
Send-out	37 (66)	18 (32)	19 (34)		6 (11)	31 (55)	
Unsure	4 (7)	2 (4)	2 (4)		0 (0)	4 (7)	
Tumor Profiling Experience				0.949			0.025
Yes	165 (83)	91 (46)	74 (37)		20 (10)	145 (72)	
No	33 (17)	18 (9)	15 (8)		9 (4)	24 (12)	
Tumor Profiling Comfort				0.659			0.004
Extremely comf.	22 (11)	14 (7)	8 (4)		2 (1)	20 (10)	
Somewhat comf.	100 (51)	57 (29)	43 (22)		8 (4)	92 (46)	
Neutral	31 (16)	16 (8)	15 (8)		9 (5)	22 (11)	
Somewhat unconf.	38 (19)	19 (9.5)	19 (9.5)		7 (4)	31 (15)	
Extremely unconf.	6 (3)	2 (1)	4 (2)		3 (2)	3 (2)	
Somatic MMR experience				0.385			0.415
Yes	161 (81)	91 (46)	70 (35)		22 (11)	139 (70)	
No	37 (19)	18 (9)	19 (10)		7 (4)	30 (15)	
Somatic MMR comfort				0.134			0.007
Extremely comf.	73 (37)	44 (23)	29 (15)		8 (6)	65 (45)	
Somewhat comf.	93 (48)	53 (27)	40 (20)		11 (8)	30 (21)	
Neutral	15 (8)	6 (3)	9 (5)		3 (2)	12 (8)	
Somewhat unconf.	12 (6)	4 (2)	8 (4)		6 (4)	6 (4)	
Extremely unconf.	2 (1)	0 (0)	2 (1)		1 (1)	1 (1)	
MMR impacts assessment				0.041			0.069
Always	46 (29)	29 (18)	17 (11)		4 (3)	42 (26)	
Usually	71 (45)	44 (28)	27 (17)		7 (4)	64 (40)	
Sometimes	29 (18)	10 (6)	19 (12)		9 (6)	20 (12)	
Rarely	10 (6)	5 (3)	5 (3)		1 (1)	9 (6)	
Never	3 (2)	3 (2)	0 (0)		0 (0)	3 (2)	
Experience/perceive barriers				0.534			0.029
Yes	149 (77)	84 (43)	65 (34)		17 (9)	132 (68)	

No	45 (23)	23 (12)	22 (11)		11 (5)	34 (18)	
Barriers**							
Cost	102 (51)	60 (30)	42 (21)	0.267	15 (8)	87 (44)	0.933
Coordinating tissue	99 (50)	52 (26)	47 (24)	0.486	10 (5)	89 (45)	0.080
Lack of institution support	35 (18)	19 (10)	16 (8)	0.925	7 (4)	28 (14)	0.309
Unsure how to interpret	12 (6)	7 (4)	5 (3)	0.811	2 (1)	10 (5)	0.687
Lack of time	17 (9)	12 (6)	5 (3)	0.177	3 (2)	14 (7)	0.718
Not available in-house	46 (23)	32 (16)	14 (7)	0.024	8 (4)	38 (19)	0.633
Not offered by preferred lab	38 (19)	26 (13)	12 (6)	0.065	6 (3)	32 (16)	0.800
Other	34 (17)	20 (10)	14 (7)	0.579	2 (1)	32 (16)	0.298
Insurance/billing issues*	9 (5)	6 (3)	3 (2)	0.518	0(0)	9(5)	0.362
Limited tissue*	6 (3)	4(2)	2(1)	0.692	0(0)	6(3)	0.596
Turnaround time*	7 (4)	3 (2)	4 (2)	0.703	0 (0)	7(4)	0.596

* Themes from text responses

Unconf. = uncomfortable

^ Only includes 'yes' responses from previous category

Conf. = comfortable

** Subcategories not mutually exclusive

The survey also investigated genetic counselor experience and comfort level with both tumor profiling and somatic MMR testing. Most individuals (83%, n = 165/198) had experience with tumor profiling results (such as those obtained from external vendors such as FoundationOne) and the majority (62%, n = 122/197) reported they felt “somewhat comfortable” or “extremely comfortable” interpreting these types of results. The majority of respondents (81%, n = 161/198) had experience reviewing somatic MMR testing results, with nearly three-quarters (73%, n = 117/159) of those results “usually contributing” or “always contributing” to the risk assessment of LS cases. When participants were asked if they do or would feel comfortable interpreting somatic MMR results, 85% (n = 166/195) reported they felt “somewhat comfortable” or “extremely comfortable”.

Over three-quarters (76.8%, n = 149/194) of respondents experienced or perceived barriers to ordering somatic MMR testing, with cost and coordinating tissue samples being the most frequently cited. The reported barriers are summarized in Figure 1. Genetic counselors at an academic institution were more likely ($p = 0.024$) to cite lack of in-house availability as a barrier to somatic MMR testing compared to those not at an academic institution. Those who work with other cancer genetic counselors were more likely to experience or perceive barriers to somatic MMR testing than those who were the sole cancer genetic counselor at their institution ($p = 0.029$).

Figure 1. Perceived barriers by participants to somatic MMR testing

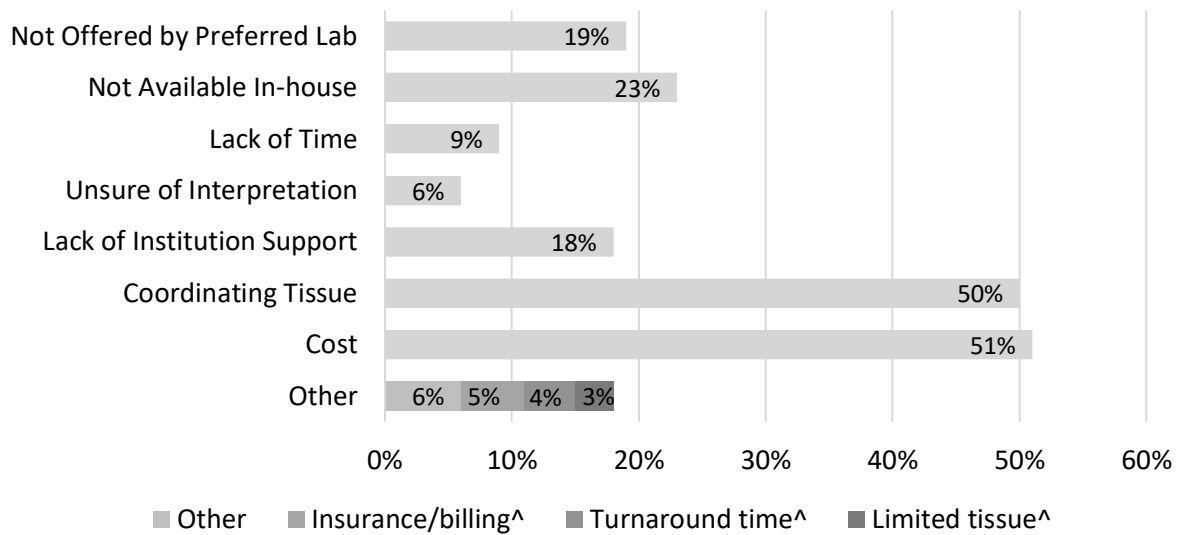

*Categories not mutually exclusive ^Themes coded from free-text responses

Scenario-based Questions:

During the scenario portion of the survey, participants were given four different theoretical scenarios created by the authors with information about a hypothetical patient's diagnosis and tumor staining results in addition to a pedigree. Question topics included the likelihood of the patient having LS (before and after learning the patient's somatic MMR results), the next recommended step in the genetics evaluation, and screening recommendations for the patient and first-degree relatives. The pedigrees for these scenarios are displayed in Figure 2.

Scenario 1 (Figure 2: A) involved a 67-year old male with colorectal cancer that had loss of staining in *MLH1* and *PMS2* with negative *MLH1* promoter methylation and *BRAF* mutation analysis. This patient was later revealed to have biallelic somatic mutations in *MLH1* with negative germline testing. Scenario 2 (Figure 2: B) was a 23-year old female with colorectal cancer and a noncontributory family history. Tumor testing showed loss of staining in *MSH2* and *MSH6*. Somatic testing showed biallelic somatic mutations in *MSH2* and germline testing was negative. Scenario 3 (Figure 2: C) showed a 46-year old female with uterine cancer and family history meeting Amsterdam criteria. The tumor IHC results were loss of staining in *MSH2* and *MSH6*. Participants were later informed her somatic testing

showed a monoallelic mutation in *MSH2* with negative germline testing. Scenario 4 (Figure 2: D) involved a 62-year old male with colorectal cancer and loss of staining in *MLH1* and *PMS2* with negative *MLH1* promoter methylation and *BRAF* mutation analysis. His family history was noncontributory, although his unaffected father died at age 52. Both the somatic and germline testing results were negative.

Figure 2. Scenario pedigrees (A-D) provided to participants.

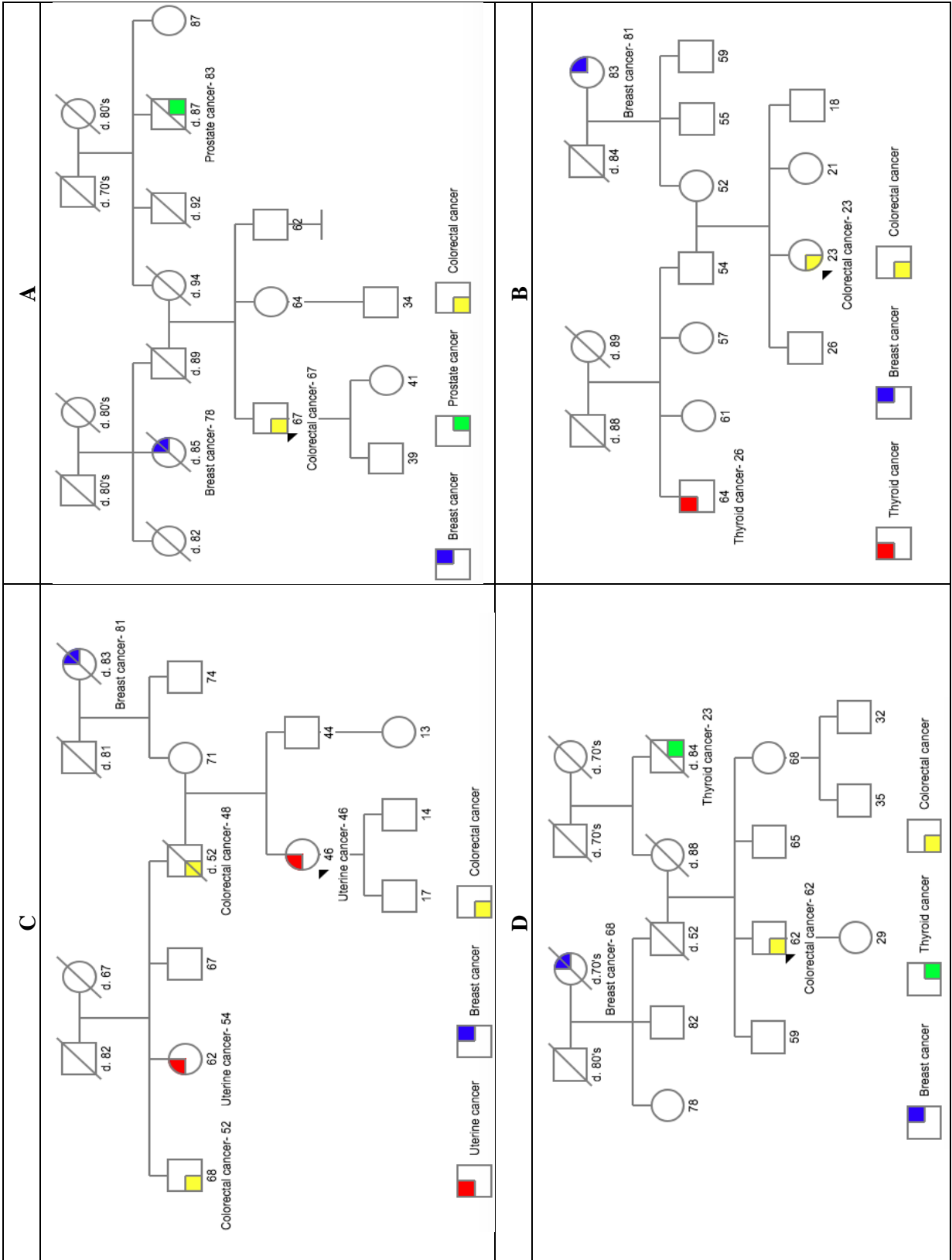

For all scenarios, the majority (52-59%) of participants indicated their next step would have been concurrent germline and somatic testing that included the MMR genes. For the scenarios involving biallelic somatic mutations, the initial likelihood for LS was mostly ranked as “unlikely” (scenario 1; 79%, n = 152/192) or “highly likely” (scenario 2; 82%, n = 155/190). After learning the somatic testing results for these scenarios, the majority (77%, n = 148/192; 89%, n = 169/190 for scenario 1 and 2, respectively) of respondents shifted to a lower LS likelihood of either “unlikely” or “definitely not”. For the scenario regarding monoallelic somatic mutations (scenario 3), most participants indicated “highly likely” before (88%, n = 165/187) and after (75%, n = 139/186) knowing the patient’s somatic results, with most (71%, n = 133/186) individuals selecting the same likelihood for both questions. Scenario 4 involved a patient with negative somatic and germline results, with most (59%, n = 105/177) individuals ranking the likelihood for LS as “unlikely” for both risk assessment questions and approximately a quarter (28%, n = 50/177) downgrading their LS suspicion. Most individuals recommended LS screening for the patient (81%, n = 149/185) with monoallelic somatic mutations (scenario 3) and her first-degree relatives (68%, n = 128/187). For the other three scenarios, the majority screening recommendation was “population-level” for the proband (48-66%) and “early colonoscopy based on family history” for the first-degree relatives (56-90%). The scenario responses are summarized in Table 3.

Table 3. Participant responses to scenario questions

	Scenario 1	Scenario 2	Scenario 3	Scenario 4
Patient	67-year old male (colorectal cx). Loss of <i>MLH1/PMS2</i> **.	23-year old female (colorectal cx). Loss of <i>MSH2/MSH6</i> .	46-year old female (uterine cx). Loss of <i>MSH2/MSH6</i> . Meets Amsterdam.	62-year old male (colorectal cx). Loss of <i>MLH1/PMS2</i> **.
Pedigree	Neg family hx. B	Neg family hx. C		Neg family hx. E
Somatic Results	*Biallelic <i>MLH1</i> somatic mut. Germline neg.	*Biallelic <i>MSH2</i> somatic mut. Germline neg.	*Monoallelic <i>MSH2</i> somatic mut. Germline neg.	*Somatic & germline negative.
	n (%)	n (%)	n (%)	n (%)
Q1. Lynch Likelihood				
Absolutely	0 (0)	0 (0)	20 (11)	0 (0)
Highly likely	40 (21)	155 (82)	165 (88)	25 (14)
Unlikely	152 (79)	35 (18)	2 (1)	151 (85)
Definitely not	0 (0)	0 (0)	0 (0)	2 (1)
Q2. Next step				
Germline	52 (27)	48 (25)	56 (30)	43 (24)
Germline reflex somatic	19 (10)	35 (18)	32 (17)	18 (10)
Germline + somatic	114 (59)	102 (54)	98 (52)	106 (59)
No further eval.	3 (2)	0 (0)	0 (0)	8 (5)
Other	4 (2)	5 (3)	1 (1)	4 (2)
Q3. *Lynch likelihood				
Absolutely	0 (0)	1 (1)	9 (5)	0 (0)
Highly likely	3 (2)	4 (2)	139 (75)	13 (7)
Unlikely	60 (31)	107 (56)	35 (19)	121 (68)
Definitely not	129 (67)	78 (41)	3 (1)	44 (25)
Q4. Proband screening				
Population	127 (66)	90 (48)	10 (5)	105 (59)
Lynch	6 (3)	13 (7)	149 (81)	18 (10)
Other	59 (31)	86 (45)	26 (14)	54 (31)
<i>Personal hx</i>	42 (22)	56 (30)	14 (8)	26 (15)
Q5. FDR screening				
Population	56 (29)	5 (3)	0 (0)	52 (29)
Family hx	122 (64)	172 (90)	45 (24)	100 (56)
Lynch	0 (0)	3 (2)	128 (68)	12 (7)
Other	13 (7)	10 (5)	14 (8)	14 (8)
Key				
*	Somatic test results provided after Q2			
**	Negative <i>MLH1</i> methylation and <i>BRAF</i> mutation analysis			

Further Guidelines and Comments:

When asked if additional, more specific, national guidelines for the ordering and/or interpretation of MMR somatic testing would be beneficial, 77% (n=140) of respondents answered ‘yes’ and 17% (n=31) responded ‘maybe’.

At the conclusion of the survey, participants were given an opportunity to provide additional comments in a free-text format. Select comments are displayed in Table 4. While extensive patterns in

the comment section did not emerge, a few individuals confirmed further guidelines would be helpful. A few others also reiterated that in their experiences, concurrent germline and somatic testing was beneficial for billing purposes. None of the comments provided explanations for individuals who indicated they did not feel further guidelines would be helpful.

Table 4. Free response examples

Theme	Example Comment
Barriers to Somatic Testing	<p>“While we may want to start with germline and then reflex to somatic (in some cases)... there is better coverage to order concurrently; so while it may not clinically be the best way to order testing, it is financially better for our patients.”</p> <p>“Turnaround time is also a contributing factor... I would sacrifice somatic results for germline results in those cases where surgical decision making regarding Lynch syndrome are reliant upon results...”</p>
Further Guidelines	<p>“Our clinic is getting more and more questions from oncologists at our institution regarding tumor testing for Lynch and other conditions. National guidelines for tumor testing in general would be extremely beneficial for cancer genetic counseling.”</p> <p>“Additional information on interpretation of MMR somatic tumor testing would be extremely beneficial. A lot has been learning as I go and I am not sure I am doing that great of a job at it...”</p>
Screening Recommendations	<p>“We make guideline recommendations based on the NCCN guidelines. In some situations, we may encourage more high risk screening methods... but we defer to the patient's supervising physician...”</p> <p>“For those with abnormal results and no informative germline/somatic results there is no clear cut recommendations and every family needs to be looked at individual and notes should include limitations to our knowledge and any recommendations.”</p>

DISCUSSION

Cancer genetic counselors currently have several tools available to assess an individual's risk of LS, including IHC staining, MSI analysis, somatic MMR testing, and germline testing. While not all of these tools may be indicated in every case, UMMRD cases may require more extensive testing to accurately determine LS status and ultimately screening recommendations for patients and their relatives. Given the importance of appropriate patient management, this study surveyed two hundred currently-practicing cancer genetic counselors regarding their current ordering practices and interpretation of somatic MMR results in the context of a hypothetical LS case to evaluate the sufficiency of current national guidelines. The results of this survey demonstrate cancer genetic counselors' acknowledged importance of somatic MMR testing in theoretical practice and in past instances, despite a scarcity of routine inclusion in real-world ordering practices.

Cancer genetic counselors seem to be largely aware of the benefits of somatic MMR testing and demonstrate interest in ordering it for their patients. Participants with past experience utilizing somatic MMR testing indicated the positive impact these results had on risk assessment. This sentiment was also reflected in the hypothetical scenarios, as a majority of participants indicated they would consider somatic MMR testing in conjunction with germline testing as the ideal next step in their LS evaluation. Previous literature has shown that patients also tend to positively view tumor screening for LS and understand its benefits (Hunter et al., 2015).

Despite genetic counselor understanding of its benefits, somatic MMR testing was rarely included in the respondents' current institution ordering practices for LS work-up. While most respondents had previous experience ordering somatic MMR testing and reported feeling at least "somewhat comfortable" with interpreting these results, only a small minority reported routinely ordering this testing. The discrepancy between ideal and current testing practices illustrates a gap, perhaps related to barriers to testing.

In fact, a high frequency of genetic counselors reported encountering or perceiving barriers to ordering somatic MMR testing. The most common reported barriers included cost, coordinating tissue

samples, and lack of in-house availability, with lack of knowledge regarding result interpretation among the least frequently cited. Many individuals reported additional barriers in the free-text response, with themes emerging in billing/insurance issues, long turnaround time, and lack of tumor tissue. Since these themes were individually reported as free-text responses and not displayed as options to all participants, these barriers may be underrepresented in this study. Previous literature regarding ordering tumor profiling found each of these three barriers to be reported in more than 70% of their participants (Kurzrock et al., 2015), which may be similar in somatic MMR testing.

Interestingly, genetic counselors who were the sole genetic counselor at their institution were less likely to report experiencing these barriers. This may be an indication that sole genetic counselors are viewed to have slightly different scopes of practice or perhaps reflects a difference in clinic structure or institution size.

The vast majority of participants reported that additional, more specific, national guidelines surrounding somatic MMR testing would be beneficial to their practice. The NCCN current guidelines (NCCN, Version 1.2018) includes limited recommendations for the interpretation of somatic MMR testing in the form of a footnote (LS-A 4 of 5; footnote d). This footnote cites evidence supporting biallelic somatic MMR mutations as an explanation for UMMRD, therefore tumor sequencing may assist in clarifying the result. It discusses that in cases with monoallelic somatic mutations, the unidentified mutation could be germline or somatic. However, the guidelines state family history-based management should be used regardless of somatic testing results. The footnote also suggests genetic consultation for complex results but doesn't provide guidelines for interpreting those results. While there are mentions of somatic MMR testing in national guidelines, it does not encompass all possible scenarios, and is not nearly as extensive as guidelines for germline testing. The creation of clear guidelines may further increase genetic counselor comfort with ordering somatic MMR testing and encourage them to seek out this testing more often, thereby enhancing patient management. Since some insurance companies use national guidelines to determine coverage criteria, this may also reduce insurance and billing issues.

Study limitations:

This study population may reflect a self-selecting bias in which those genetic counselors with experience or interest in somatic MMR testing may have been more likely to complete the survey than those with more limited knowledge. In addition, the questionnaire was created by the authors and has not been formally validated. While most participant characteristics were not significantly different between this study and the PSS, including licensure and regions 1-5, this study may have had a higher proportion of genetic counselors who worked at a public medical facility and a lower proportion of genetic counselors in region 6, which could have created a skewed sample. However, the work setting differences may simply be a reflection of different answer choices included on this survey compared to those of the PSS. Additionally, the NCCN guidelines underwent revisions within a few months of survey distribution which changed recommendations for those with monoallelic somatic mutations from LS screening to family history-based screening. Therefore, individuals may have made recommendations for LS screening as a reflection of prior guidelines.

Of note, for three of the scenario questions, it was observed that a majority of participants chose “population-level screening” for a proband affected with cancer. However, individuals with a history of cancer generally require additional screening compared to the general population in order to monitor for disease recurrence. Therefore, this survey response may represent an artifact of the survey structure or wording for this specific question. While the authors intended this to represent typical post-cancer screening protocols, this phrase may have been interpreted differently by respondents. Given the only other provided response was LS screening, this option may have been understood as non-LS screening or as typical screening for the colon/uterine cancer population. Therefore, conclusions could not be drawn regarding these responses.

Practice Implications:

This study provides insights into the ordering practices of cancer genetic counselors in evaluating for LS, interpretations of somatic MMR testing, and barriers to this testing. Since many of the

reported barriers involved lab-related issues rather than knowledge, it may be beneficial for genetic counselors to advocate for different lab billing practices or in-house somatic MMR testing to ensure this option is available, especially for UMMRD cases.

While many genetic counselors reported some level of comfort with interpreting somatic MMR testing results, further guidelines may allow for further consensus, higher comfort levels, and portray benefit to insurance companies. This may provide genetic counselors with more guideline resources, confidence in their abilities to interpret somatic MMR testing, and leverage when advocating for this testing option. Further guidelines may also reflect larger consensus and wider acceptance as a risk assessment tool, which may aid in lowering costs and improving insurance coverage.

Research Recommendations:

Further studies investigating the barriers to somatic MMR testing may be beneficial in determining strategies for eliminating or reducing those barriers. These potential studies could also explore and confirm the differences between sole genetic counselors and those who work along with other genetic counselors in terms of ordering practices, comfort with somatic testing, and likelihood to report barriers to somatic MMR testing. Advancements in genetic knowledge and cancer technologies may create other avenues for LS risk assessment or reveal other explanations for UMMRD, which may alter ordering practices. Future research could compare ordering practices over time to find other factors contributing to the rate of testing uptake and accessibility of new testing options.

APPENDIX

Appendix A. Complete survey of this study

Start of Block: Consent

Q1 You are invited to take part in a research study called, “**Genetic Counselor Utilization and Interpretation of Somatic Tumor Testing for Lynch Syndrome**”, conducted by Danielle Williams, of The University of Texas MD Anderson Cancer Center UTHealth Graduate School of Biomedical Sciences.

The purpose of this study is to describe current clinical practice among genetic counselors seeing cancer patients for evaluation of Lynch syndrome. All board-certified or board-eligible genetic counselors who see cancer patients are invited to participate, regardless of exposure to somatic tumor testing.

If you consent to take part in this study you will complete a 15-20 minute survey via the online survey tool, Qualtrics. All survey submissions will be anonymous.

The information you provide will help us better understand current clinical practices of cancer genetic counselors evaluating patients for Lynch syndrome. You may not receive any direct benefit from taking part in this study. The only possible risk may be breach of confidentiality; the information collected will not contain identifying information. You have the alternative to choose to not take part in this study and may withdraw at any time.

There is no cost and you will not be paid to take part in this study. You will not be personally identified in any reports or publications that may result from this study. Any personal information about you that is gathered during this study will remain confidential to every extent of the law.

This research project has been reviewed by the Committee for the Protection of Human Subjects (CPHS) of the University of Texas Health Science Center at Houston (HSC-MS-18-0442). For any questions about research subjects rights call CPHS at (713) 500-7943. This study is being conducted by M.S. Candidate Danielle Williams under the direction of Maureen Mork, M.S., C.G.C. Should you have any questions, please feel free to contact either at danielle.williams@uth.tmc.edu or memork@mdanderson.org.

- I have read the consent and agree to take part in the study (1)
- I do not provide my consent and/or do not wish to take part in the study (2)

Skip To: End of Survey If You are invited to take part in a research study called, “Genetic Counselor Utilization and Inter... = I do not provide my consent and/or do not wish to take part in the study

Start of Block: Qualification Questions

Q2 Are you a currently practicing, board certified or board eligible, genetic counselor who sees patients for evaluation of hereditary cancer?

- Yes (1)
- No (2)

Skip To: End of Survey If Are you a currently practicing, board certified or board eligible, genetic counselor who sees pat... = No

Q3 Do you work in a clinical or non-clinical setting?

- I am a clinical counselor and counsel patients as a regular part of my job (1)
- I am a non-clinical counselor and typically do not counsel patients (2)

Skip To: End of Survey If Do you work in a clinical or non-clinical setting? = I am a non-clinical counselor and typically do not counsel patients

Start of Block: Demographics

Q4 For how many years have you been seeing patients for evaluation of hereditary cancer?

- 0-5 years (1)
- 6-10 years (2)
- 11-15 years (3)
- 16-20 years (4)
- 20+ years (5)

Q5 Do you work as a genetic counselor full-time or part-time?

- Part-time (1)
- Full-time (>30 hours per week) (2)

Q6 What type of setting do you work in? *Select all that apply*

- Public hospital/medical facility (1)
- Private hospital/medical facility (2)
- University Medical Center (3)
- Physician's private practice (4)
- Diagnostic laboratory (5)
- Other (6) _____

Display This Question: If What type of setting do you work in? Select all that apply = Diagnostic laboratory

Q7 Does your employer offer somatic MMR testing? (Haraldsdottir et al., 2014; Mensenkamp et al., 2014; NCCN, Version 3.2017)

- Yes (1)
- No (2)

Skip To: End of Survey If Does your employer offer somatic MMR testing?... = No

Q8 Do you consider your workplace to be an academic or non-academic institution?

- Academic (1)
- Non-academic (2)

Q9 Do you exclusively see cancer cases?

- Yes (1)
- No, I see other specialties as well (2)

Display This Question: If Do you exclusively see cancer cases? = No, I see other specialties as well

Q10 What other specialties do you see? *Select all that apply*

- General genetics (1)
- Pediatrics (2)
- Adult genetics (3)
- Cardiology (4)
- Neurogenetics (5)
- Metabolic diseases (6)
- Prenatal (7)
- Other (8) _____

Q11 Do you specialize in a certain domain within the cancer setting?

- Yes (1)

- No, I practice in a general cancer genetics setting (2)

Display This Question: If Do you specialize in a certain domain within the cancer setting? = Yes

Q12 Which cancer domain do you specialize in? *Select all that apply*

- Breast (1)
- Gynecological (2)
- Gastrointestinal (GI) (3)
- Genitourinary (GU) (4)
- Endocrine (5)
- Dermatology (6)
- Pediatric (7)
- Other (8) _____

Q13 Do you work with other cancer genetic counselors?

- Yes, I work with other cancer genetic counselors (1)
- No, I am the only cancer genetic counselor at my institution (2)

Q14 In which region do you currently practice?

- Region 1 (CT, MA, ME, NH, RI, VT, CN Maritime Provinces) (1)
- Region 2 (DC, DE, MD, NJ, NY, PA, VA, WV, PR, VI, Quebec) (2)
- Region 3 (AL, FL, GA, KY, LA, MS, NC, SC, TN) (3)
- Region 4 (AR, IA, IL, IN, KS, MI, MN, MO, ND, NE, OH, OK, SD, WI, Ontario) (4)
- Region 5 (AZ, CO, MT, NM, TX, UT, WY, Alberta, Manitoba, Sask) (5)
- Region 6 (AK, CA, HI, ID, NV, OR, WA, British Columbia) (6)

Q15 Does your state/province currently have licensure?

- Yes (1)
- No (2)

Start of Block: Current practices

Q16 About how many cases (personal or family history) do you see **per month** for colorectal cancer?

Q17 About how many cases (personal or family history) do you see **per month** for uterine cancer?

Q18 Does your institution include immunohistochemistry (IHC) tumor staining in the work-up for Lynch syndrome?

- Yes (1)
- No (2)
- Unsure (3)

Display This Question: If Does your institution include immunohistochemistry (IHC) tumor staining in the work-up for Lynch... = Yes

Q19 Is IHC testing performed in-house or through a send-out laboratory?

- In-house (1)
- Send-out (2)
- Unsure (3)

Q20 Does your institution include microsatellite instability (MSI) testing in the work-up for Lynch syndrome?

- Yes (1)
- No (2)
- Unsure (3)

Display This Question: If Does your institution include microsatellite instability (MSI) testing in the work-up for Lynch s... = Yes

Q21 Is MSI testing performed in-house or through a send-out laboratory?

- In-house (1)
- Send-out (2)
- Unsure (3)

Q22 Does your institution include somatic tumor testing of the mismatch repair (MMR) genes in the work-up for Lynch syndrome? (Haraldsdottir et al., 2014; Mensenkamp et al., 2014; NCCN, Version 3.2017)

- Yes (1)
- No (2)
- Unsure (3)

Display This Question: If Does your institution include somatic tumor testing of the mismatch repair (MMR) genes in the wor... = Yes

Q23 Is MMR somatic tumor testing performed in-house or through a send-out laboratory?

- In-house (1)
- Send-out (2)
- Unsure (3)

Q24 Do you have experience with tumor profiling testing results (FoundationOne)?

- Yes (1)
- No (2)

Q25 How comfortable do you feel interpreting tumor profiling results (FoundationOne)?

- Extremely comfortable (1)
- Somewhat comfortable (2)
- Neither comfortable nor uncomfortable (3)
- Somewhat uncomfortable (4)
- Extremely uncomfortable (5)

Q26 Have you ever ordered and/or coordinated somatic tumor testing of the MMR genes in evaluation of Lynch syndrome?

- Yes (1)
- No (2)

Display This Question: If Have you ever ordered and/or coordinated somatic tumor testing of the MMR genes in evaluation of... = Yes

Q27 Have you ever ordered and/or coordinated somatic testing of the MMR in evaluation of Lynch syndrome for a **colon** tumor?

- Yes (1)
- No (2)

Display This Question: If Have you ever ordered and/or coordinated somatic tumor testing of the MMR genes in evaluation of... = Yes

Q28 Have you ever ordered and/or coordinated somatic testing of the MMR genes in evaluation of Lynch syndrome for a **uterine** tumor?

- Yes (1)

- No (2)

Display This Question: If Have you ever ordered and/or coordinated somatic tumor testing of the MMR genes in evaluation of... = Yes

Q29 Is somatic MMR testing utilized when are evaluating a patient for Lynch syndrome?

- Rarely (1)
- Occasionally (10-30% of the time) (2)
- Often (30-80% of the time) (3)
- Routinely (>80% of the time) (4)

Q30 Have you ever reviewed/interpreted colon or uterine MMR somatic tumor testing results?

- Yes (1)
- No (2)

Display This Question: If Have you ever reviewed/interpreted colon or uterine MMR somatic tumor testing results? = Yes

Q31 In the cases where you have reviewed/interpreted somatic MMR tumor testing results, did those results contribute to your Lynch syndrome risk assessment?

- Always (100% of the time) (1)
- Usually (70-99% of the time) (2)
- Sometimes (30-70% of the time) (3)
- Rarely (1-30% of the time) (4)
- Never (0% of the time) (5)

Display This Question: If Have you ever reviewed/interpreted colon or uterine MMR somatic tumor testing results? = No

Q32 What are the reasons that contribute to not reviewing/interpreting colon or uterine MMR somatic tumor testing results? *Select all that apply*

- I don't feel comfortable interpreting somatic tumor testing results (1)
- I have not received training for interpreting somatic tumor testing results (2)
- The results wouldn't contribute to my risk assessment (3)
- My institution doesn't order somatic testing (4)
- We have other providers to do this (5)
- I don't have time to review the results (6)
- My institution does not consider this part of the genetic counseling scope (7)
- Other (8) _____

Q33 Have you experienced or perceive any barriers to ordering somatic MMR testing?

- Yes (1)
- No (2)

Q34 What are the barriers you have experienced or perceive? *Select all that apply*

- Cost (1)
- Coordinating tissue samples (2)
- Lack of institution support (3)
- Unsure how to interpret the results (4)

- Lack of time (5)
- Not available in-house (6)
- Not offered by preferred genetic testing lab(s) (7)
- Other (8) _____

Q35 Do/would you feel comfortable interpreting colon and/or uterine MMR somatic tumor testing results and including them in your risk assessment?

- Extremely comfortable (1)
- Somewhat comfortable (2)
- Neither comfortable nor uncomfortable (3)
- Somewhat uncomfortable (4)
- Extremely uncomfortable (5)

Start of Block: Scenario 1

Q36 The following questions refer to the scenario below:

Mr. Smith is a 67-year old male recently diagnosed with colorectal cancer. Tumor testing revealed loss of staining in *MLH1* and *PMS2*. *MLH1* promoter methylation and *BRAF* mutation analysis were both negative. The patient's family history is below:

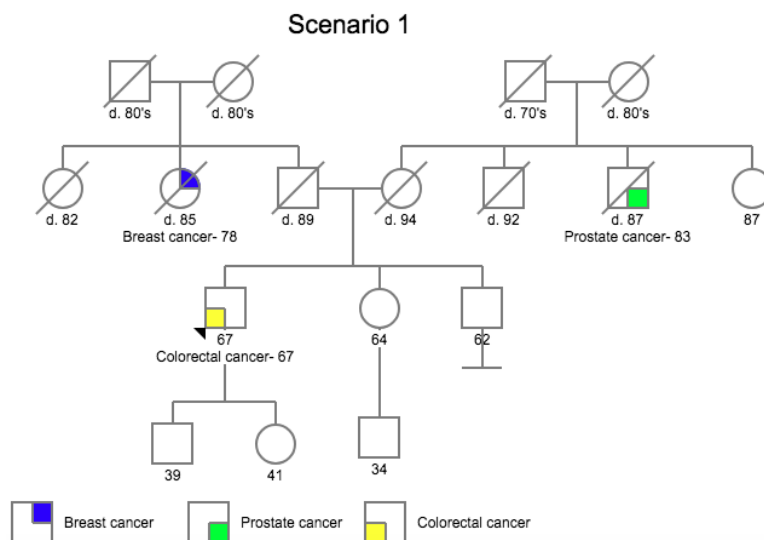

Q38 What would you perceive this patient's chance of having Lynch syndrome to be?

- This patient absolutely has Lynch syndrome (1)
- It's highly likely this patient has Lynch syndrome (2)
- It's unlikely this patient has Lynch syndrome (3)
- This patient definitely does not have Lynch syndrome (4)

Q39 What would be your next step in evaluating this patient for Lynch syndrome?

- Germline testing to include MMR genes (1)
- Germline testing to include MMR genes with reflex to somatic MMR testing if negative (2)
- Concurrent germline testing to include MMR genes plus somatic MMR testing (3)
- No further evaluation (4)
- Other (5) _____

Q40 Somatic MMR testing reveals biallelic somatic mutations in *MLH1*. Germline testing for MMR genes was negative. Given this additional information, what do you perceive this patient's chance of having Lynch syndrome to be?

- This patient absolutely has Lynch syndrome (1)
- It's highly likely this patient has Lynch syndrome (2)
- It's unlikely this patient has Lynch syndrome (3)
- This patient definitely does not have Lynch syndrome (4)

Q41 What screening recommendations would you give this patient?

- Population-level screening (1)
- Lynch syndrome screening (2)
- Other (3) _____

Q42 What screening recommendations would you give this patient's first-degree relatives?

- Population-level screening (1)
- Earlier colonoscopy based on family history (2)
- Lynch syndrome screening (3)
- Other (4) _____

Start of Block: Scenario 2

Q43 The following questions refer to the scenario below:

Ms. Jones is a 23-year old female recently diagnosed with colorectal cancer. Tumor testing revealed loss of staining in *MSH2* and *MSH6*. The patient's family history is below:

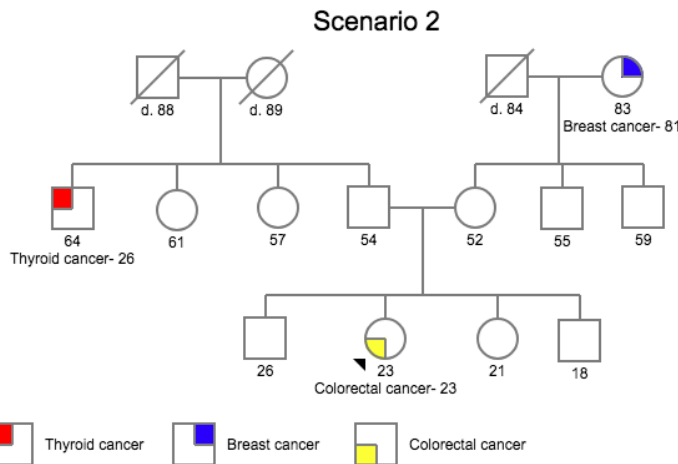

Q44 What would you perceive this patient's chance of having Lynch syndrome to be?

- This patient absolutely has Lynch syndrome (1)
- It's highly likely this patient has Lynch syndrome (2)
- It's unlikely this patient has Lynch syndrome (3)
- This patient definitely does not have Lynch syndrome (4)

Q45 What would be your next step in evaluating this patient for Lynch syndrome?

- Germline testing to include MMR genes (1)
- Germline testing to include MMR genes with reflex to somatic MMR testing if negative (2)
- Concurrent germline testing to include MMR genes plus somatic MMR testing (3)
- No further evaluation (4)
- Other (5) _____

Q46 Somatic MMR testing reveals biallelic somatic mutations in *MSH2*. Germline testing for MMR genes was negative. Given this additional information, what do you perceive this patient's chance of having Lynch syndrome to be?

- This patient absolutely has Lynch syndrome (1)
- It's highly likely this patient has Lynch syndrome (2)
- It's unlikely this patient has Lynch syndrome (3)
- This patient definitely does not have Lynch syndrome (4)

Q47 What screening recommendations would you give this patient?

- Population-level screening (1)
- Lynch syndrome screening (2)
- Other (3) _____

Q48 What screening recommendations would you give this patient's first-degree relatives?

- Population-level screening (1)
- Earlier colonoscopy based on family history (2)
- Lynch syndrome screening (3)
- Other (4) _____

Start of Block: Scenario 3

Q49 The following questions refer to the scenario below:

Ms. Davis is a 46-year old female recently diagnosed with uterine cancer. Tumor testing revealed loss of staining in *MSH2* and *MSH6*. The patient's family history is below:

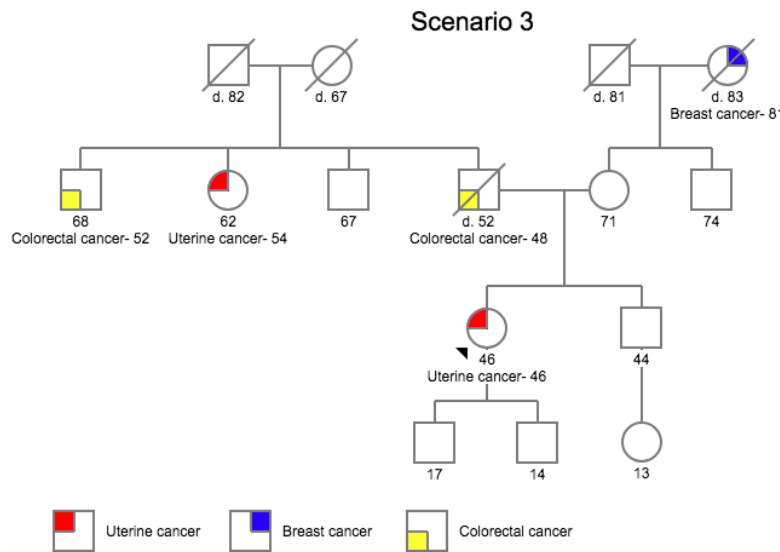

Q50 What would you perceive this patient's chance of having Lynch syndrome to be?

- This patient absolutely has Lynch syndrome (1)
- It's highly likely this patient has Lynch syndrome (2)
- It's unlikely this patient has Lynch syndrome (3)
- This patient definitely does not have Lynch syndrome (4)

Q51 What would be your next step in evaluating this patient for Lynch syndrome?

- Germline testing to include MMR genes (1)
- Germline testing to include MMR genes with reflex to somatic MMR testing if negative (2)
- Concurrent germline testing to include MMR genes plus somatic MMR testing (3)
- No further evaluation (4)

- Other (5) _____

Q52 Somatic MMR testing reveals a monoallelic somatic mutation in *MSH2*. Germline testing for MMR genes was negative. Given this additional information, what do you perceive this patient's chance of having Lynch syndrome to be?

- This patient absolutely has Lynch syndrome (1)
- It's highly likely this patient has Lynch syndrome (2)
- It's unlikely this patient has Lynch syndrome (3)
- This patient definitely does not have Lynch syndrome (4)

Q53 What screening recommendations would you give this patient?

- Population-level screening (1)
- Lynch syndrome screening (2)
- Other (3) _____

Q54 What screening recommendations would you give this patient's first-degree relatives?

- Population-level screening (1)
- Earlier colonoscopy based on family history (2)
- Lynch syndrome screening (3)
- Other (4) _____

Start of Block: Scenario 4

Q55 The following questions refer to the scenario below:

Mr. Roberts is a 62-year old male recently diagnosed with colorectal cancer. Tumor testing revealed a loss of staining in *MLH1* and *PMS2*. *MLH1* promoter methylation and *BRAF* mutation analysis were both negative. The patient's family history is below:

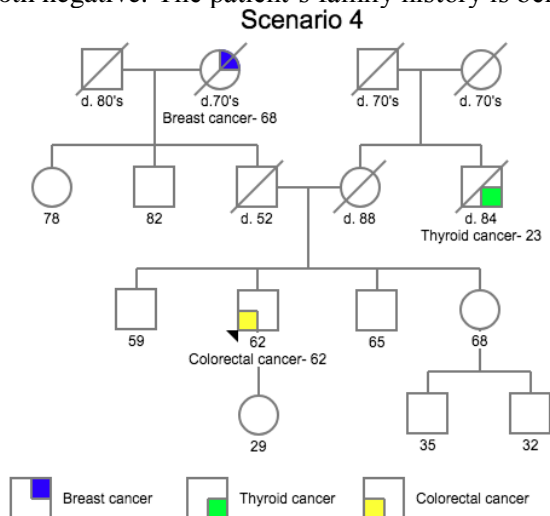

Q56 What would you perceive this patient's chance of having Lynch syndrome to be?

- This patient absolutely has Lynch syndrome (1)
- It's highly likely this patient has Lynch syndrome (2)
- It's unlikely this patient has Lynch syndrome (3)
- This patient definitely does not have Lynch syndrome (4)

Q57 What would be your next step in evaluating this patient for Lynch syndrome?

- Germline testing to include MMR genes (1)

- Germline testing to include MMR genes with reflex to somatic MMR testing if negative (2)
- Concurrent germline testing to include MMR genes plus somatic MMR testing (3)
- No further evaluation (4)
- Other (5) _____

Q58 Somatic MMR testing and germline testing for MMR genes were both negative. Given this additional information, what do you perceive this patient's chance of having Lynch syndrome to be?

- This patient absolutely has Lynch syndrome (1)
- It's highly likely this patient has Lynch syndrome (2)
- It's unlikely this patient has Lynch syndrome (3)
- This patient definitely does not have Lynch syndrome (4)

Q59 What screening recommendations would you give this patient?

- Population-level screening (1)
- Lynch syndrome screening (2)
- Other (3) _____

Q60 What screening recommendations would you give this patient's first-degree relatives?

- Population-level screening (1)
- Earlier colonoscopy based on family history (2)
- Lynch syndrome screening (3)
- Other (4) _____

Start of Block: Conclusion

Q60 Would additional, more specific, national guidelines for ordering and/or the interpretation of MMR somatic tumor testing be beneficial to you?

- Yes (1)
- Maybe (2)
- No (3)
- Unsure (4)

Q61 Do you have any additional comments that were not addressed by this survey?

Bibliography:

- Battaglin, F., Naseem, M., Lenz, H.-J., & Salem, M. E. (2018). Microsatellite instability in colorectal cancer: overview of its clinical significance and novel perspectives. *Clinical Advances in Hematology & Oncology: H&O*, *16*(11), 735–745.
- Batte, B. A. L., Bruegl, A. S., Daniels, M. S., Ring, K. L., Dempsey, K. M., Djordjevic, B., Broaddus, R. R. (2014). Consequences of universal MSI/IHC in screening endometrial cancer patients for lynch syndrome. *Gynecologic Oncology*, *134*(2), 319–325. <https://doi.org/10.1016/j.ygyno.2014.06.009>
- Buecher, B., De Pauw, A., Bazire, L., Houdayer, C., Fievet, A., Moncoutier, V., Golmard, L. (2018). Sporadic endometrial adenocarcinoma with MMR deficiency due to biallelic MSH2 somatic mutations. *Familial Cancer*, *17*(2), 281–285. <https://doi.org/10.1007/s10689-017-0032-8>
- Cohen, S. A. (2014). Current Lynch Syndrome Tumor Screening Practices: A Survey of Genetic Counselors. *Journal of Genetic Counseling*, *23*(1), 38–47. <https://doi.org/10.1007/s10897-013-9603-5>
- Deng, G., Bell, I., Crawley, S., Gum, J., Terdiman, J. P., Allen, B. A., Kim, Y. S. (2004). BRAF Mutation Is Frequently Present in Sporadic Colorectal Cancer with Methylated hMLH1, But Not in Hereditary Nonpolyposis Colorectal Cancer. *Clinical Cancer Research*, *10*(1), 191–195. <https://doi.org/10.1158/1078-0432.CCR-1118-3>
- Goedde, L. N., Stupiansky, N. W., Lah, M., Quaid, K. A., & Cohen, S. (2017). Cancer Genetic Counselors' Current Practices and Attitudes Related to the Use of Tumor Profiling. *Journal of Genetic Counseling*, *26*(4), 878–886. <https://doi.org/10.1007/s10897-017-0065-z>
- Hampel, H., Pearlman, R., Beightol, M., Zhao, W., Jones, D., Frankel, W. L., Pritchard, C. C. (2018). Assessment of Tumor Sequencing as a Replacement for Lynch Syndrome Screening and Current Molecular Tests for Patients with Colorectal Cancer. *JAMA Oncology*, *4*(6), 806–813. <https://doi.org/10.1001/jamaoncol.2018.0104>
- Haraldsdottir, S., Hampel, H., Tomsic, J., Frankel, W. L., Pearlman, R., de la Chapelle, A., & Pritchard, C. C. (2014). Colon and Endometrial Cancers with Mismatch Repair Deficiency Can Arise From Somatic,

Rather Than Germline, Mutations. *Gastroenterology*, 147(6), 1308-1316.e1.

<https://doi.org/10.1053/j.gastro.2014.08.041>

Hemminger, J. A., Pearlman, R., Haraldsdottir, S., Knight, D., Jonasson, J. G., Pritchard, C. C., Frankel, W. L.

(2018). Histology of colorectal adenocarcinoma with double somatic mismatch-repair mutations is indistinguishable from those caused by Lynch syndrome. *Human Pathology*, 78, 125–130.

<https://doi.org/10.1016/j.humpath.2018.04.017>

Hunter, J. E., Zepp, J. M., Gilmore, M. J., Davis, J. V., Esterberg, E. J., Muessig, K. R., Goddard, K. A. B.

(2015). Universal tumor screening for Lynch syndrome: Assessment of the perspectives of patients with colorectal cancer regarding benefits and barriers. *Cancer*, 121(18), 3281–3329.

<https://doi.org/10.1002/cncr.29470>

Kurzrock, R., Colevas, A. D., Olszanski, A., Akerley, W., Arteaga, C. L., Carson, W. E., Stewart, F. M.

(2015). NCCN Oncology Research Program’s Investigator Steering Committee and NCCN Best Practices Committee Molecular Profiling Surveys. *Journal of the National Comprehensive Cancer Network*, 13(11), 1337–1346. <https://doi.org/10.6004/jnccn.2015.0163>

Lynch, H. T., Snyder, C. L., Shaw, T. G., Heinen, C. D., & Hitchins, M. P. (2015). Milestones of Lynch syndrome: 1895-2015. *Nature Reviews. Cancer; London*, 15(3), 181–194.

<http://dx.doi.org/10.1038/nrc3878>

McGivern, A., Wynter, C. V. A., Whitehall, V. L. J., Kambara, T., Spring, K. J., Walsh, M. D., Jass, J. R.

(2004). Promoter Hypermethylation Frequency and BRAF Mutations Distinguish Hereditary Non-Polyposis Colon Cancer from Sporadic MSI-H Colon Cancer. *Familial Cancer*, 3(2), 101–107.

<https://doi.org/10.1023/B:FAME.0000039861.30651.c8>

Mensenkamp, A. R., Vogelaar, I. P., van Zelst–Stams, W. A. G., Goossens, M., Ouchene, H., Hendriks–

Cornelissen, S. J. B., Ligtenberg, M. J. L. (2014). Somatic Mutations in MLH1 and MSH2 Are a Frequent Cause of Mismatch-Repair Deficiency in Lynch Syndrome-Like Tumors. *Gastroenterology*,

146(3), 643-646.e8. <https://doi.org/10.1053/j.gastro.2013.12.002>

- National Comprehensive Cancer Network (NCCN). (2018). *Genetic/Familial High-Risk Assessment: Colorectal*. Retrieved from https://www.nccn.org/professionals/physician_gls/
- National Society of Genetic Counselors : NSGC Professional Status Survey. (2018). Retrieved April 2, 2019, from <https://www.nsgc.org/p/cm/ld/fid=68>
- Peña-Díaz, J., & Rasmussen, L. J. (2016). Approaches to diagnose DNA mismatch repair gene defects in cancer. *DNA Repair*, 38, 147–154. <https://doi.org/10.1016/j.dnarep.2015.11.022>
- Pritchard, C. C., Smith, C., Salipante, S. J., Lee, M. K., Thornton, A. M., Nord, A. S., Walsh, T. (2012). ColoSeq Provides Comprehensive Lynch and Polyposis Syndrome Mutational Analysis Using Massively Parallel Sequencing. *The Journal of Molecular Diagnostics*, 14(4), 357–366. <https://doi.org/10.1016/j.jmoldx.2012.03.002>
- Sourrouille, I., Coulet, F., Lefevre, J. H., Colas, C., Eyries, M., Svrcek, M., Soubrier, F. (2012). Somatic mosaicism and double somatic hits can lead to MSI colorectal tumors. *Familial Cancer*, 12(1), 27–33. <https://doi.org/10.1007/s10689-012-9568-9>
- Tiwari, A. K., Roy, H. K., & Lynch, H. T. (2016). Lynch syndrome in the 21st century: clinical perspectives. *QJM: An International Journal of Medicine*, 109(3), 151–158. <https://doi.org/10.1093/qjmed/hcv137>
- Varga, E., Chao, E. C., & Yeager, N. D. (2015). The importance of proper bioinformatics analysis and clinical interpretation of tumor genomic profiling: a case study of undifferentiated sarcoma and a constitutional pathogenic BRCA2 mutation and an MLH1 variant of uncertain significance. *Familial Cancer*, 14(3), 481–485. <https://doi.org/10.1007/s10689-015-9790-3>
- Vasen, H. F. A., Watson, P., Mecklin, J., & Lynch, H. T. (1999). New clinical criteria for hereditary nonpolyposis colorectal cancer (HNPCC, Lynch syndrome) proposed by the International Collaborative Group on HNPCC. *Gastroenterology*, 116(6), 1453–1456. [https://doi.org/10.1016/S0016-5085\(99\)70510-X](https://doi.org/10.1016/S0016-5085(99)70510-X)

Danielle Rae Williams was born in Colorado, the daughter of Connie and Aaron Williams. After completing her work at Rock Canyon High School, Lone Tree, CO in 2012, she entered the University of Colorado in Boulder, Colorado. She received the degree of Bachelor of Arts with a major in molecular, cellular, and developmental biology from the University of Colorado in May 2016. For the next year, she worked as a genetic counseling assistant at the Huntsman Cancer Institute in Salt Lake City, Utah. In August of 2017, she entered The University of Texas MD Anderson Cancer Center UTHealth Graduate School of Biomedical Sciences.