

MORPHOLOGY AND NEUROMUSCULAR PROPERTIES  
OF CHELAE OF DECAPOD CRUSTACEAN SPECIES  
FROM TEMPERATE AND TROPICAL POPULATIONS

by  
Jay Arthur Blundon

Maryland  
LD  
3231  
.M70d  
Blundon,  
J.A.  
Folio

Dissertation submitted to the Faculty of the Graduate School  
of the University of Maryland in partial fulfillment  
of the requirements for the degree of  
Doctor of Philosophy  
1986

C.1

APPROVAL SHEET

Title of Dissertation: Morphology and neuromuscular  
properties of chelae of decapod  
crustacean species from temperate  
and tropical populations

Name of Candidate: Jay Arthur Blundon  
Doctor of Philosophy, 1986

Dissertation and Abstract Approved:

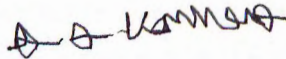

Geerat J. Vermeij  
Professor  
Department of Zoology

Date Approved:

11/11/86

acclimated stone crab fibers. Fiber membrane resistance of rapid cold acclimated blue crabs equalled that of winter stone crabs.

Both species of decapods showed no seasonal differences in chela muscle performance. Their ability to function over wide ranges of temperatures is undoubtedly essential in their successful latitudinal distribution. The difference in the capacity of these two species to rapidly acclimate to cold temperatures is reflected in their natural habitats. C. *sapidus* lives in estuaries where large short term temperature fluctuations are common. M. *mercenaria*, a marine coastal subtidal dweller, lives where temperature fluctuations are smaller.

## PREFACE

Animals are constantly influenced by the environment in which they live. Physical factors in the environment (temperature, salinity, pressure, humidity, etc.) often affect major body functions such as metabolism, growth, reproduction, and locomotion. Biological influences such as predators and competitors may affect a species' distribution, reproductive fitness, and mortality rate.

Adaptations to cope with one's environment may take the form of changes in whole body morphology or may be so specific as to occur at the molecular level of a gene. Transplanting an organism to a new environment may result in changes in physiology to acclimate to new conditions. However, adaptations to one's local conditions may be so finely tuned as to make acclimation to different conditions difficult.

This dissertation examines the role of local environmental conditions in influencing morphology and physiology within species that, at the extreme ranges of distribution, experience different temperature regimes. This was accomplished by studying chela (or claw) morphology and neuromuscular physiology in temperate and tropical populations of stone crabs Menippe mercenaria (Say) and chela neuromuscular physiology in northern and southern populations of blue crabs Callinectes sapidus Rathbun.

Chapter 1 compares chela morphology and muscle stress between tropical and temperate M. mercenaria. Greater predatory and competitive interactions amongst crabs in the tropics (where diversity is higher) and increased prey exoskeleton strength (i.e. greater molluscan calcification) may result in greater selection for crabs in the tropics to increase chela strength relative to their temperate conspecifics. Decreased chela use in temperate crabs during the winter could potentially result in seasonal changes in their chela strength. However, I found no differences in



chela morphology amongst tropical and temperate M. mercenaria. Furthermore, when tested at summer temperatures commonly experienced by both populations, tropical and temperate stone crabs were capable of exerting similar levels of chela muscle stress.

Chapter 2 examines chela neuromuscular properties of the two populations of stone crabs over a wide range of temperatures normally experienced only by the temperate crabs. When tropical crabs were transported to the temperate location and subjected to the natural summer-winter decrease in temperature, they showed cold acclimation capability equal to that of temperate crabs. However, neither crab population was capable of acclimating to temperate winter temperatures when the rate of temperature decrease was artificially increased in the laboratory. This was not surprising given that M. mercenaria, which lives in subtidal marine waters, rarely encounters temperature fluctuations such as those applied in the laboratory.

Chapter 3 reports on a similar study of the effects of temperature change and acclimation time on chela neuromuscular properties of northern and southern blue crabs Callinectes sapidus Rathbun. Not only were both blue crab populations able to exert equal forces with their chelae at summer and temperate winter conditions, but they were also capable of acclimating to the temperature decrease quite rapidly. The estuarine environment where blue crabs live is much more prone to sizable short term temperature fluctuations relative to the marine environment.

Chapters 2 and 3 demonstrate that one difference in warm and cold acclimated crabs can be found within passive properties of the chela muscle fiber. The ability to rapidly acclimate to sizable temperature changes may be reflected in the rate of change in either proteins or lipids within the muscle fiber membrane.

## ACKNOWLEDGEMENTS

My appreciation goes to committee members William Higgins, Herbert Levitan, Anthony Olek, Sidney Pierce, Geerat Vermeij, and Fred Wheaton for their assistance during all stages of this study. Collection of crabs in the field would not have been possible were it not for the help of Gary Graves (and Key Fisheries, Inc. of Marathon, FL), Michael Greene, Robert McConnaughey, and Daniel Rittschof. Fred Wheaton and the Agricultural Engineering machine shop of the University of Maryland designed and built the force transducer. Use of the Instron testing machine was granted by the Agricultural Engineering department. Alan Teramura gave me the use of his surface area meter. Estelle Russek Cohen assisted with statistics comparing slopes and elevations of regression lines. Philip Stephens commented on an early draft of Chapter 2.

I'd like to express special thanks to C. K. Govind, Herbert Levitan, and my major professor Gary Vermeij for their teaching, encouragement, and support during my years as a graduate student.

My wife, Lettie, frequently acted as field, lab, and computer assistant but most importantly always gave me encouragement, patience, and love.

This research was funded by National Science Foundation doctoral dissertation improvement grant # BNS-8414345 and by University of Maryland Chesapeake Bay research funds.

## TABLE OF CONTENTS

List of Tables	. . . . .	vi
List of Figures	. . . . .	vii
Chapter 1. Morphology and muscle stress of chelae of temperate and tropical stone crabs <u>Menippe mercenaria</u> (Say)	. . . . .	1
Introduction	. . . . .	2
Methods	. . . . .	4
Results	. . . . .	12
Discussion	. . . . .	28
References	. . . . .	35
Chapter 2. Effects of temperature on neuromuscular properties of chelae of temperate and tropical stone crabs <u>Menippe mercenaria</u> (Say)	. . . . .	38
Introduction	. . . . .	39
Methods	. . . . .	42
Results	. . . . .	48
Discussion	. . . . .	65
Appendix	. . . . .	73
References	. . . . .	77
Chapter 3. Effects of temperature and cold acclimation on neuromuscular properties of chelae in blue crabs <u>Callinectes sapidus</u> Rathbun	. . . . .	81
Introduction	. . . . .	82
Methods	. . . . .	84
Results	. . . . .	87
Discussion	. . . . .	101
Appendix	. . . . .	104
References	. . . . .	107



## LIST OF TABLES

Chapter 1

Table I	Regression equations for morphological and muscle stress measurements of <u>M. mercenaria</u> chelae	. . 13
Table II	Mechanical advantages of male and female temperate and tropical <u>M. mercenaria</u> chelae	. . 21

Chapter 2

Table III	Muscle stress values of <u>M. mercenaria</u> chelae at various temperature treatments	. 49
Table IV	Neuromuscular properties of <u>M. mercenaria</u> chela closer muscle fibers	. 54
Table V	Levels of excitatory post-synaptic potential summation in <u>M. mercenaria</u> chela closer muscle fibers	. 56
Table VI	Temperature associated changes in passive properties of muscle fibers of <u>M. mercenaria</u> chelae	. 63

Chapter 3

Table VII	Muscle stresses and dactyl tip forces of chelae of <u>C. sapidus</u>	. . 88
Table VIII	Neuromuscular properties of <u>C. sapidus</u> chela closer muscle fibers	. . . 90
Table IX	Speed of dactyl movement in <u>C. sapidus</u> chelae	. . . 95
Table X	Temperature associated changes in passive properties of muscle fibers of <u>C. sapidus</u> chelae	. . . 99

## LIST OF FIGURES

<u>Chapter 1</u>		
Figure 1	<u>M. mercenaria</u> chelae . . . . .	6
Figure 2	Force transducer . . . . .	8
Figure 3	<u>M. mercenaria</u> crusher length as a function of carapace width . . . . .	15
Figure 4	<u>M. mercenaria</u> cutter length as a function of carapace width . . . . .	17
Figure 5	<u>M. mercenaria</u> apodeme area as a function of chela length . . . . .	19
Figure 6	Muscle stress as a function of chela length in tropical and temperate <u>M. mercenaria</u> crusher chelae . . . . .	24
Figure 7	Dactyl tip force as a function of chela length in temperate and tropical <u>M. mercenaria</u> crusher chelae . . . . .	26
<u>Chapter 2</u>		
Figure 8	Muscle stress versus chela length in summer and winter temperate <u>M. mercenaria</u> crusher chelae . . . . .	51
Figure 9	Excitatory post-synaptic potentials from chela closer muscles of <u>M. mercenaria</u> . . . . .	58
Figure 10	Muscle fiber specific membrane resistance in chela closer muscles of <u>M. mercenaria</u> . . . . .	61
<u>Chapter 3</u>		
Figure 11	Excitatory post-synaptic potentials from chela closer muscles of <u>C. sapidus</u> . . . . .	92
Figure 12	Muscle fiber specific membrane resistance in chela closer muscles of <u>C. sapidus</u> . . . . .	97



## CHAPTER 1

Morphology and muscle stress of chelae  
of temperate and tropical stone crabs

Menippe mercenaria (Say)

## INTRODUCTION

This study tests the hypothesis that tropical members of a species are stronger than temperate ones. To test this hypothesis, comparisons of chela morphology and muscle stress were made of temperate and tropical populations of the stone crab Menippe mercenaria (Say). This study also serves to introduce a new method of recording chela force in live crabs, and compares results with those achieved with techniques used by others.

In studies of the distributions of decapod predators, Vermeij (1976, 1977) has noted that, within many genera (e.g. Callinectes, Carcinus, Cancer), tropical decapods possess larger chelae (relative to body size) than temperate congeners. One hypothesis to explain the pattern of decapod distribution would be that the decreased thermal energy of temperate regions may place limits on the amount of energy that is allocated toward other functions not directly involved in body maintenance, such as chela growth, muscle performance or calcification of the exoskeleton. Increased solubility of calcium carbonate at lower temperatures (Revelle and Fairbridge, 1957) no doubt increases energy costs associated with forming an exoskeleton in temperate regions.

Biological interactions among decapods may also have played a significant role in the evolution of chelae. Vermeij (1978) noted that the increased frequency of specialized crushing decapods parallels worldwide patterns of decapod diversity. In general, the greater diversity found in the tropics has been associated with a more stable environment, a greater area and a higher level of productivity (see Pianka, 1966 for review). The interaction of crabs with their own competitors and predators would be greatest in the tropics. Over an evolutionary time scale, the greater selection in the tropics to resist predators and competitors may serve to increase fighting ability

(i.e. relative chela size).

In addition to chela size, other properties of chela morphology and physiology may be important in affecting strength. Increases in muscle volume, mechanical advantage, and muscle fiber stress would all increase chela strength.

Tropical crabs within a latitudinally widespread species may possess enhanced muscle strength due to continuous exercise that occurs with year round feeding. The intensity of exercise in the tropics may be greater because tropical mollusc prey show greater exoskeleton calcification or because greater diversity of crabs may result in more fighting (Vermeij, 1976, 1978). Chela muscle exercise significantly affects muscle development and maintenance of muscle performance in some decapods by changing sarcomere length (Abby-Kalio and Warner, 1984; Govind and Pearce, 1986).

Data from this study indicate no differences in chela morphology between temperate and tropical M. mercenaria. Chela muscle stress measurements taken from both populations during the summer (at tropical temperatures) were also similar. Actual values of muscle stress recorded from live crabs were higher than values reported previously for other Crustacea. This difference may indicate the inability of other techniques to record maximum stress values often generated for a brief instant when a crab first uses its chela.



## METHODS

Menippe mercenaria is found from North Carolina to the Florida Keys, including the Bahamas and northwest Cuba (Williams, 1984). The two chelae of the stone crabs are functionally and morphologically distinct. The chela used for crushing the prey (the crusher claw) has large proximal molars on the dactyl and propus. It is larger than the cutter claw, which functions mainly in extracting and manipulating prey flesh. The cutter chela also lacks large molars but instead has smaller incisor-like teeth (Brown et alia, 1979). Stone crabs are highly specialized and powerful decapod crushers. Any differences in chela performance between temperate and tropical populations should be easier to resolve in such an animal compared to one of weaker strength.

Temperate stone crabs were found among the crevices of a nearshore jetty near Beaufort, North Carolina, in less than ten feet of water, and could easily be removed by hand. Tropical crabs from Marathon, Florida were caught by a combination of stone crab pots, lobster pots, and by hand. Adult crabs there were found in burrows in sandy substrate, typically in ten to twenty feet of water. Collection of crabs for this study took place during the summers of 1984 and 1985. Water temperature was approximately 27°C in North Carolina and 29°C in Florida.

Measurements of muscle stress were used to compare the crushing abilities among temperate and tropical crabs. Muscle stress (newtons  $\text{cm}^{-2}$ ) is related to the amount of force exerted on the apodeme of the dactyl by fibers of the closer muscle. Such measurements are comparable between animals because they take into account muscle size (in terms of apodeme area), mechanical advantage and angle of muscle fiber attachment onto the apodeme (angle of pinna-tion), three variables that can each affect the magnitude of force at the dactyl. Mechanical advantage of a chela is

a ratio that describes the leverage with which the closer muscle produces force (Alexander, 1968). It is represented by  $L_1/L_2$ , where  $L_1$  is the distance from the point of apodeme insertion onto the dactyl to the dactyl pivot and  $L_2$  is the distance from the dactyl pivot to the dactyl tip (Figure 1). A greater mechanical advantage results in a higher resultant force; a lesser mechanical advantage results in faster movement of the dactyl. Since it is not muscle stress that is felt by a prey that is being crushed or an enemy that is being fought, measurements of dactyl force were also reported.

Immediately after capture, crabs were induced to squeeze together two steel rods of a force transducer by placing the rods near the proximal end of the dactyl. Force exerted on these rods was transferred to a stainless steel hydraulic cylinder equipped with a pressure gauge (Figure 2). The transducer was calibrated in the field by hanging a weight along various lengths of the upper rod. In the laboratory, calibration with many forces was done by applying forces to the transducer with an Instron compressive testing machine. The location of force application on the crab's chela and on the rods was measured with vernier calipers.

The force applied to the transducer, ( $F_{\text{transducer}}$ ), was used to calculate the force applied to the dactyl by the closer muscle ( $F_1$ ) at the point of apodeme insertion (Figure 1). Assuming the dactyl pivot to be frictionless,

$$(F_{\text{transducer}})(L_{\text{transducer}}) = (F_1)(L_1),$$

$L_{\text{transducer}}$  is the distance along the dactyl from where the transducer was squeezed to the dactyl pivot. Muscle stress ( $S$ ) was calculated using  $F_1$ , the area of one side of the apodeme ( $A$ ) and the angle of muscle fiber pinnation ( $\theta$ ) with formulae given by Alexander (1969). For a muscle at rest whose fibers insert onto the apodeme at an angle  $\theta_r$ , and whose total apodeme area (both sides) is  $2A$ , then the total cross sectional area of the muscle measured perpendi-



Figure 1. Chelae of a juvenile Menippe mercenaria. Chelae of adults can reach lengths over 120 mm. Scale = 10 mm

### CRUSHER

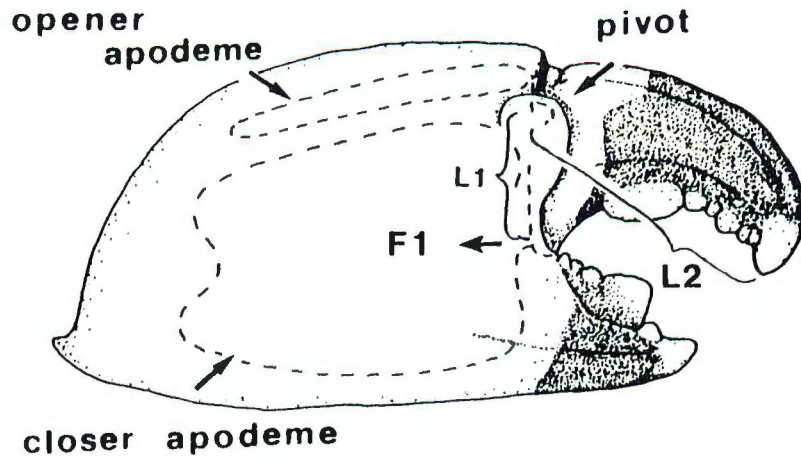

### CUTTER

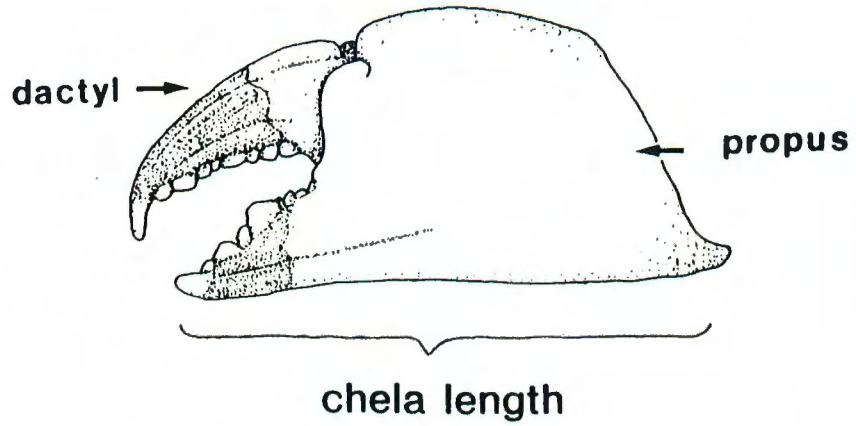
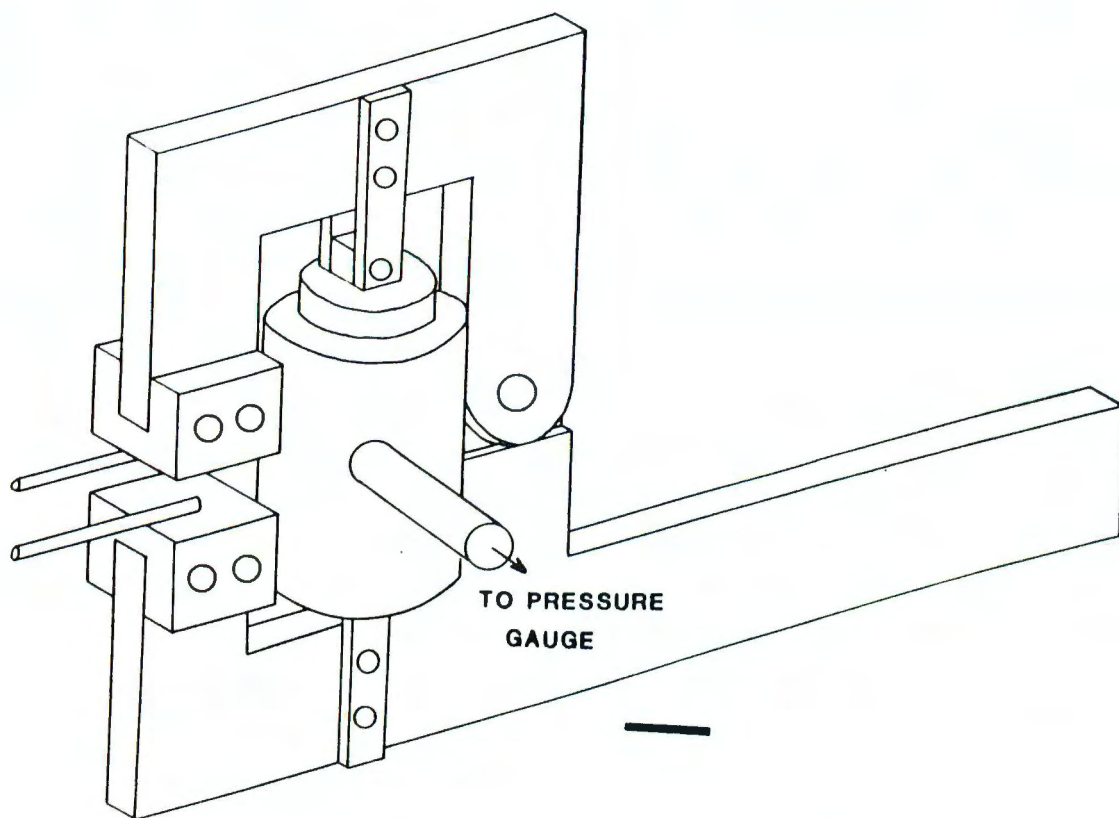

Figure 2. Force transducer used in measuring grip force of M. mercenaria chelae. Scale = 2 cm



cularly to the longitudinal axis of the fibers is

$$2A\sin\theta_r.$$

The angle of pinnation of the contracted muscle ( $\theta_c$ ) is slightly lower than when the muscle is at rest. The contracted fibers exert a stress  $S$  per unit cross sectional area of the muscle. The total force on the apodeme is then

$$(S)(2A\sin\theta_r).$$

The component of force that is applied to the dactyl of the chela ( $F_1$ ) acts along the length of the apodeme, and is

$$(S)(2A\sin\theta_r)(\cos\theta_c).$$

Since  $\theta_r$  is close to  $\theta_c$ , this simplifies to

$$F_1 = (S)(2A)(\sin\theta_c)(\cos\theta_c)$$

or

$$F_1 = (S)(A)(\sin 2\theta_c).$$

Muscle stress is directly calculated from:

$$S = F_1/(A)(\sin 2\theta_c).$$

After completing force measurements, crabs were made to autotomize their chelipeds by inserting a dissecting pin distal to the plane of autotomy between the basis and the ischium. The closer muscle was exposed by removing the dorsal exoskeleton of the propus and the opener muscle. The chela was then fixed in an open position (15 mm between dactyl tip and pollex tip, approximately the same distance the chelae were opened when squeezing the force transducer). A drawing of the dorsal muscle fiber arrangement along the apodeme was made with a camera lucida. Angles of pinnation were measured with a protractor. Apodeme surface area was measured with a surface area meter that is typically used to measure two dimensional area of leaves. All other chela dimensions were measured with vernier calipers to the nearest 0.1 mm.

Comparisons of the means of mechanical advantages from chelae of different populations and sexes were performed with a one-way analysis of variance (ANOVA) followed by a Student-Neuman-Keuls multiple comparison procedure. Bartlett's test for homogeneity of variance was performed prior



to the ANOVA (Sokal and Rohlf, 1969).

Least squares regression analysis was used to determine if there was a significant relationship between chela length and crab carapace width as well as apodeme area and chela length. Because both ordinate and abscissa values may contain measurement error, the commonly used Model I regression analysis may not accurately predict the functional relationship between X and Y values. Ricker (1973) suggested that the geometric mean regression more accurately predicts the relationship between X and Y. The geometric mean slope is simply the Model I regression slope divided by  $r$  (the correlation coefficient), and in instances where X and Y are highly correlated, the Model I regression slope approximates the GM regression slope. A test statistic described by Clarke (1980) compared the slopes of the geometric mean regression lines. If two regression lines had equal slopes, elevations were compared with analysis of covariance described by Snedecor (1956).

## RESULTS

Chela morphology

Comparisons of slopes and elevations of regressions of chela structural measurements showed no difference between temperate and tropical *M. mercenaria*. (Table I, Figures 3,4,5). North Carolina but not Florida female crabs had smaller crushers relative to carapace width than did males (Table I, Figure 3). Male crusher chelae were significantly larger than the cutter chelae (Table I, not tested for females). Differences in muscle size were apparent between crushers and cutters as seen in the regression of square root of apodeme area versus chela length (Table I, Figure 5). Here also there were no differences between temperate and tropical populations.

Angle of pinnation, measured for 10 to 20 fibers along the dorsal surface of the chela closer muscle, varied along the distal-proximal axis, being least at the proximal end of the muscle. Because all angle measurements were taken from chelae with a 15 mm gap between dactyl tip and pollex tip, different angles of pinnation were found for different chela sizes. The dactyl tip of a 62 mm (chela length) crusher opened 15 mm was rotated approximately 37°, while that of a 110 mm crusher was rotated only about 20°. For both populations, crusher chelae in the size range of 62 to 77 mm chela length had a closer muscle angle of pinnation of approximately 25°. Larger chelae (size range 88 to 110 mm chela length) had an angle of pinnation of approximately 35°. Cutter chela from both populations had an angle of pinnation of approximately 24°. There was no significant difference in this angle through a cutter size range of 55 to 93 mm chela length.

Mechanical advantage was the same among crushers from both populations and sexes, as it was for the cutters. Crushers had a significantly higher mechanical advantage than did cutters (Table II).

Table I. Regression equations of chela morphological and muscle stress measurements of temperate (NC) and tropical (FL) M. mercenaria. Coefficient of determination =  $r^2$ , n = sample size

## CHELA LENGTH (y mm) VS. CARAPACE WIDTH (x mm)

	y =	<u>slope</u>	+	<u>intercept</u>	<u>r<sup>2</sup></u>	<u>n</u>
NC male cutter		<sup>a</sup> 1.01x		- 23.45 <sup>A</sup>	0.955	12
FL male cutter		<sup>a</sup> 1.11x		- 32.07 <sup>A</sup>	0.997	7
NC male crusher		<sup>a</sup> 1.25x		- 33.97 <sup>B</sup>	0.962	19
FL male crusher		<sup>a</sup> 1.22x		- 30.45 <sup>B</sup>	0.965	26
NC female crusher		<sup>a</sup> 0.86x		- 9.46 <sup>C</sup>	0.890	27
FL female crusher		<sup>a</sup> 1.42x		- 49.96 <sup>B</sup>	0.825	6

## SQRT APODEME AREA (y cm) VS. CHELA LENGTH (x mm)

	y =	<u>slope</u>	+	<u>intercept</u>	<u>r<sup>2</sup></u>	<u>n</u>
NC crusher		<sup>b</sup> 0.033x	+	0.286 <sup>D</sup>	0.943	47
FL crusher		<sup>b</sup> 0.030x	+	0.317 <sup>D</sup>	0.836	30
NC cutter		<sup>b</sup> 0.029x	+	0.129 <sup>E</sup>	0.957	22
FL cutter		<sup>b</sup> 0.030x	-	0.065 <sup>E</sup>	0.950	6

MUSCLE STRESS (y N/cm<sup>2</sup>) VS. CHELA LENGTH (x mm)

	In y =	<u>slope</u>	+	<u>intercept</u>	<u>r<sup>2</sup></u>	<u>n</u>
NC crusher 30 C		<sup>c</sup> -0.028x	+	6.532 <sup>F</sup>	0.528	27
FL crusher 30 C		<sup>c</sup> -0.026x	+	6.841 <sup>F</sup>	0.629	6

a, A

similar superscripts denote no difference in regression line slopes (lower case) or elevations (capitals) (P > 0.05)

Figure 3. Crusher chela length as a function of carapace width for temperate (NC) and tropical (FL) M. mercenaria



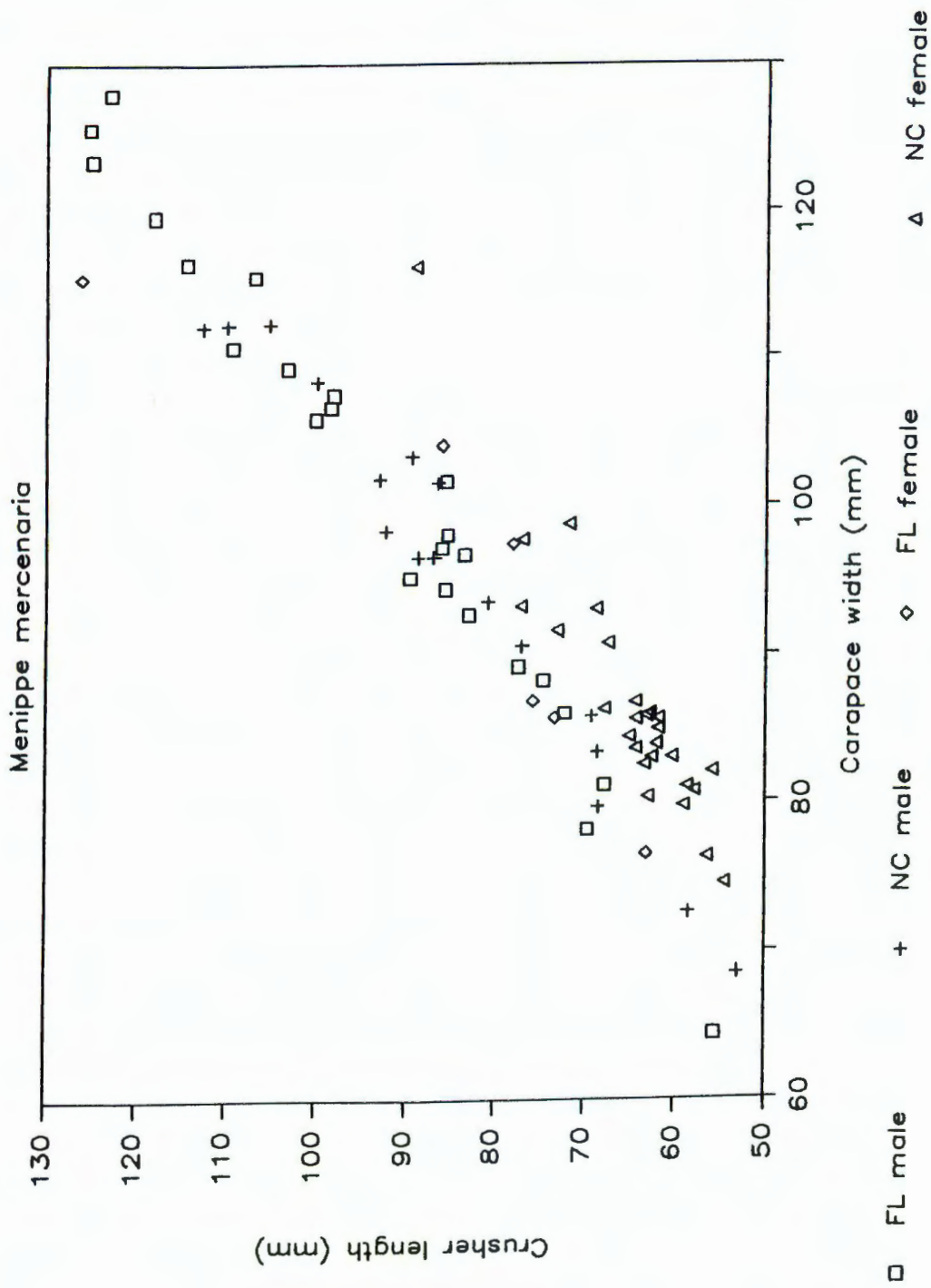

Figure 4. Cutter chela length as a function of carapace width for temperate and tropical M. mercenaria

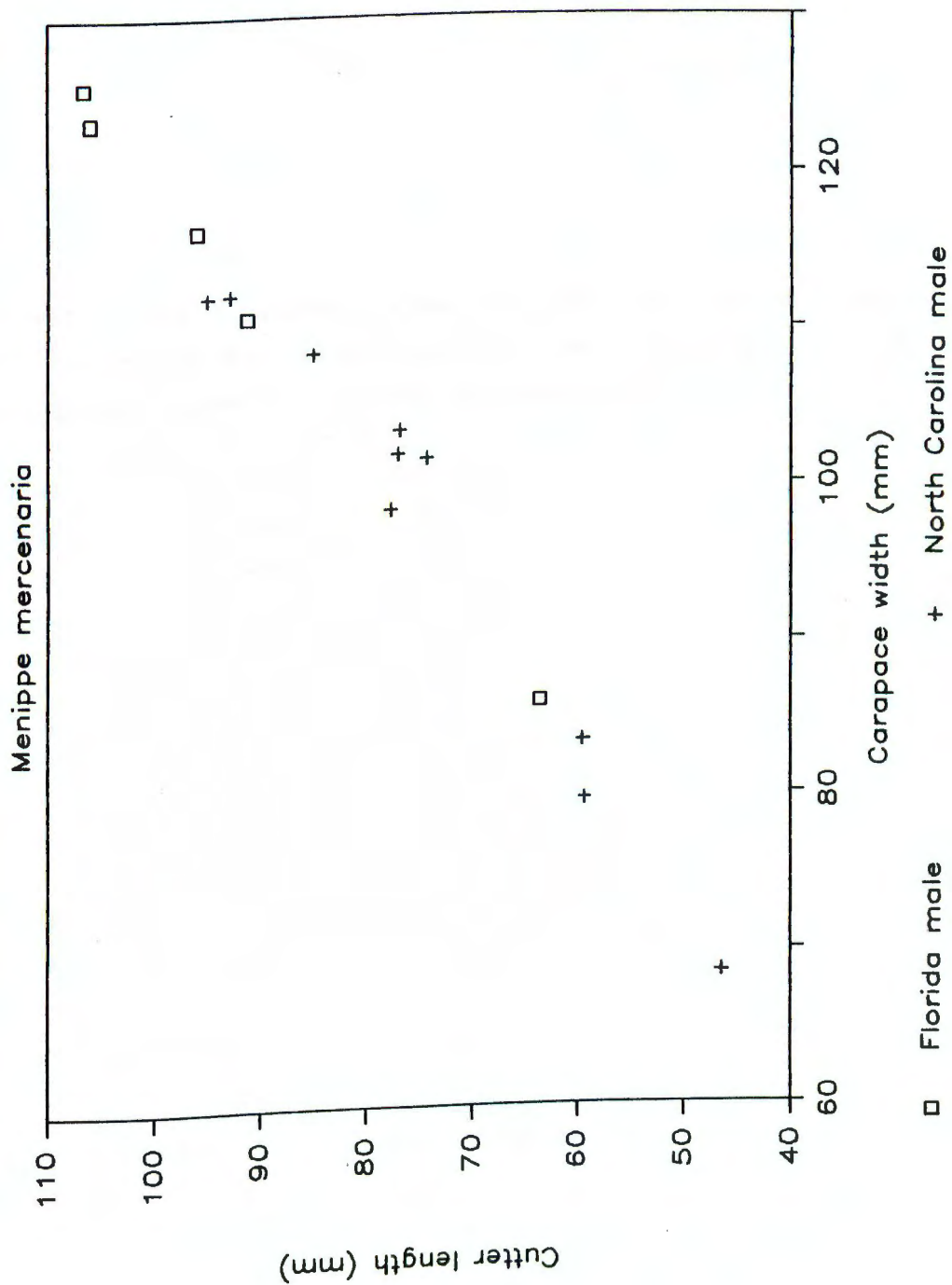

Figure 5. Chela apodeme area (square root) as a function of chela length for temperate (NC) and tropical (FL) M. mercenaria crushers (Cr) and cutters (Cu)



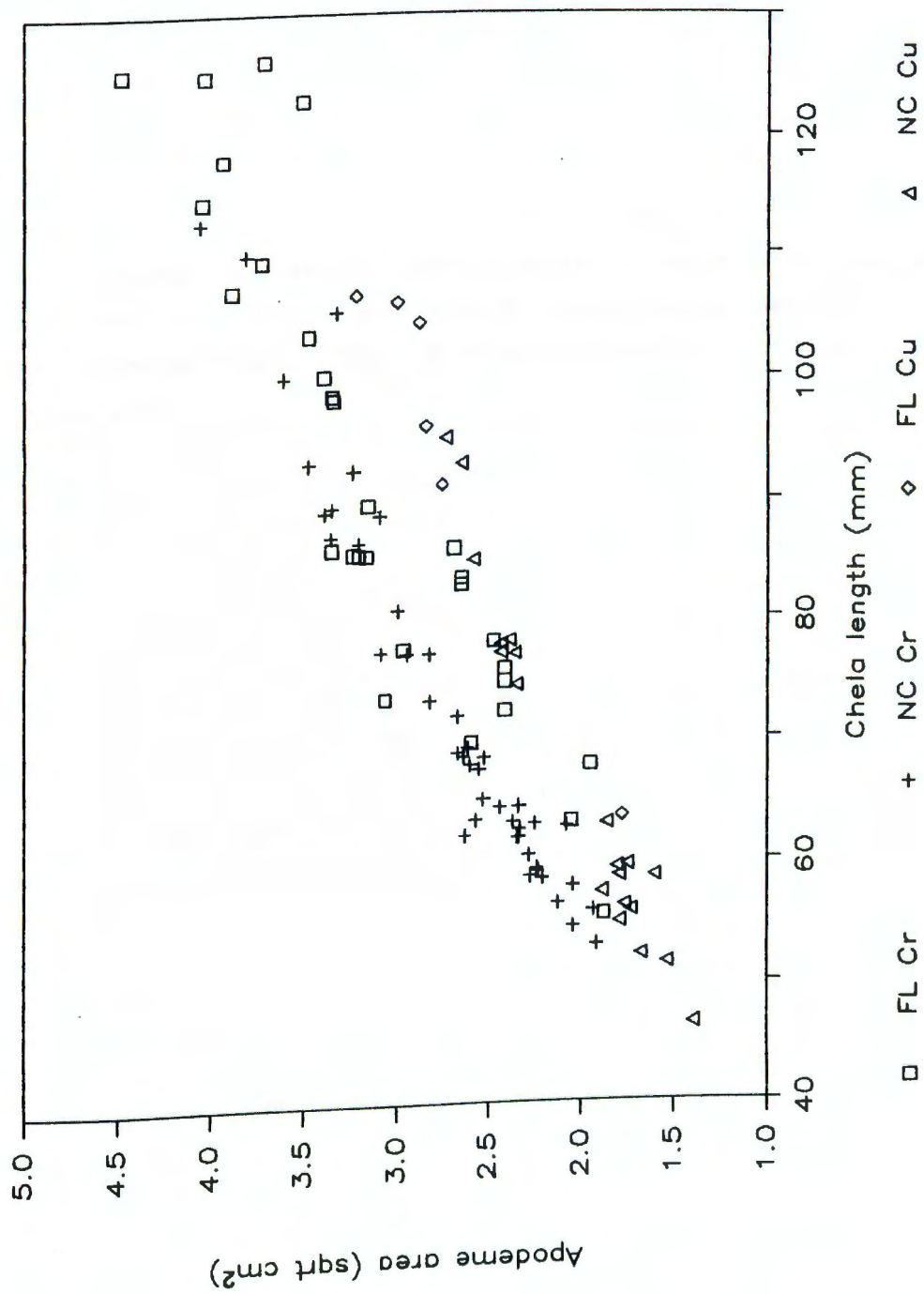

Table II. Chela mechanical advantages of male and female temperate (NC) and tropical (FL) M. mercenaria crushers (Cr) and cutters (Cu). SEM = standard error of means, n = sample size

## CHELA MECHANICAL ADVANTAGE

Mean  $\pm$  SEM (n)

	<u>Crusher</u>	<u>Cutter</u>
NC male	<sup>a</sup> 0.390 $\pm$ 0.008 (19)	<sup>b</sup> 0.314 $\pm$ 0.005 (12)
NC female	<sup>a</sup> 0.400 $\pm$ 0.006 (28)	<sup>b</sup> 0.298 $\pm$ 0.008 (10)
FL male	<sup>a</sup> 0.384 $\pm$ 0.006 (24)	<sup>b</sup> 0.302 $\pm$ 0.006 ( 5)
FL female	<sup>a</sup> 0.387 $\pm$ 0.019 ( 6)	<sup>b</sup> 0.302 $\pm$ 0.020 ( 2)

a, b  
similar superscripts denote no significant difference  
between means (P > 0.05)

### Chela closer muscle performance

Muscle stress for crushers of both populations showed a significant relationship with length which was best predicted by a negative exponential curve. Both slopes and elevations of these curves were identical for the two populations (Table I, Figure 6). On the other hand, cutter muscle stress did not change with size for either population. It was therefore not possible to compare functional relationships of stress versus chela length between asymmetric chela of individuals. Mean cutter muscle stress was 67.3 ( $\pm$  9.96 SEM, n = 9) for temperate crabs and 89.6 ( $\pm$  8.97 SEM, n = 6) for tropical crabs. Actual crusher force at the dactyl tip increased with chela size for North Carolina but not for Florida stone crabs (Figure 7).



Figure 6. Muscle stress as a function of chela length for temperate (NC) and tropical (FL) warm acclimated M. mer-  
cenaria crusher chelae (30°C)

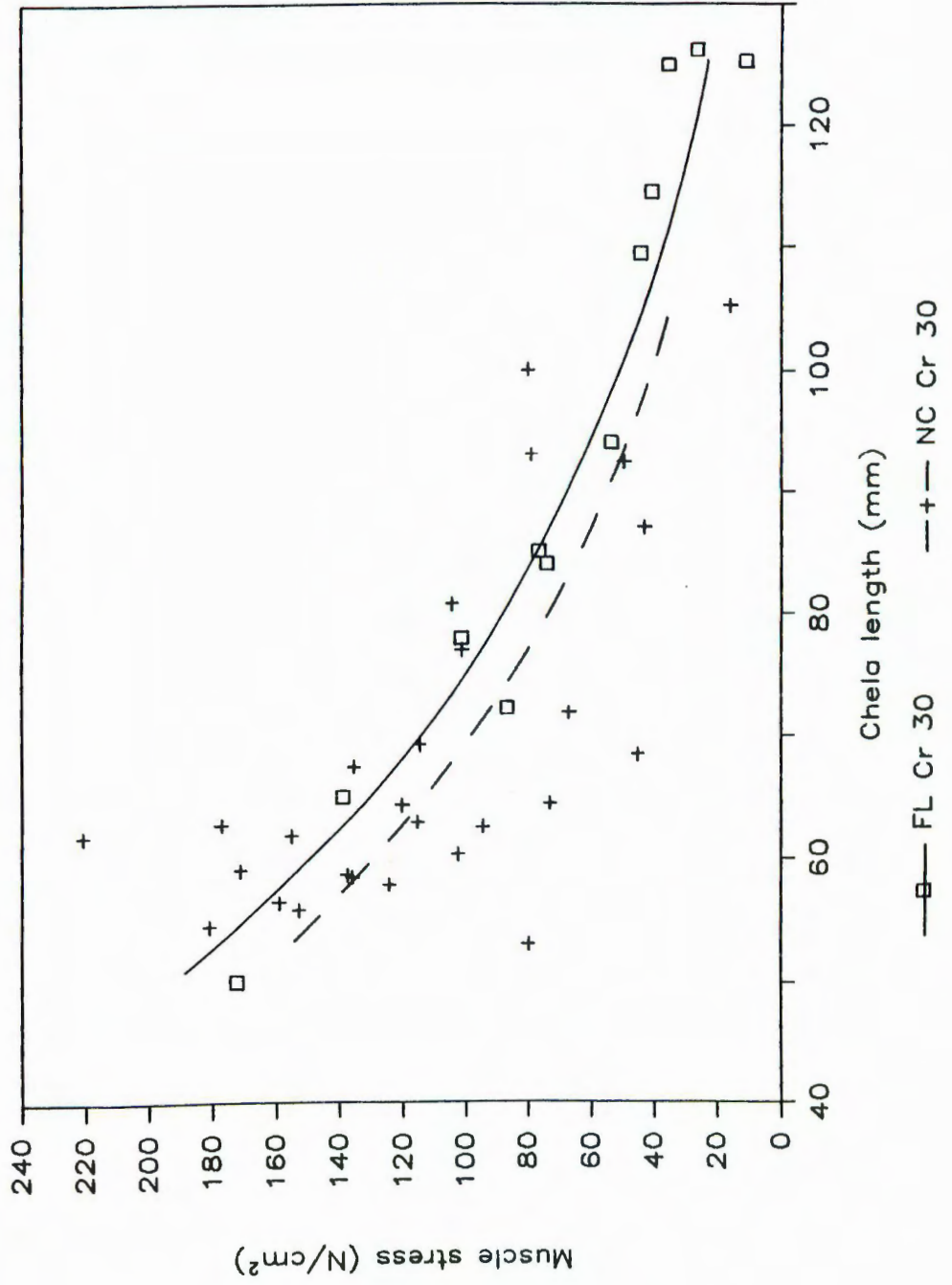
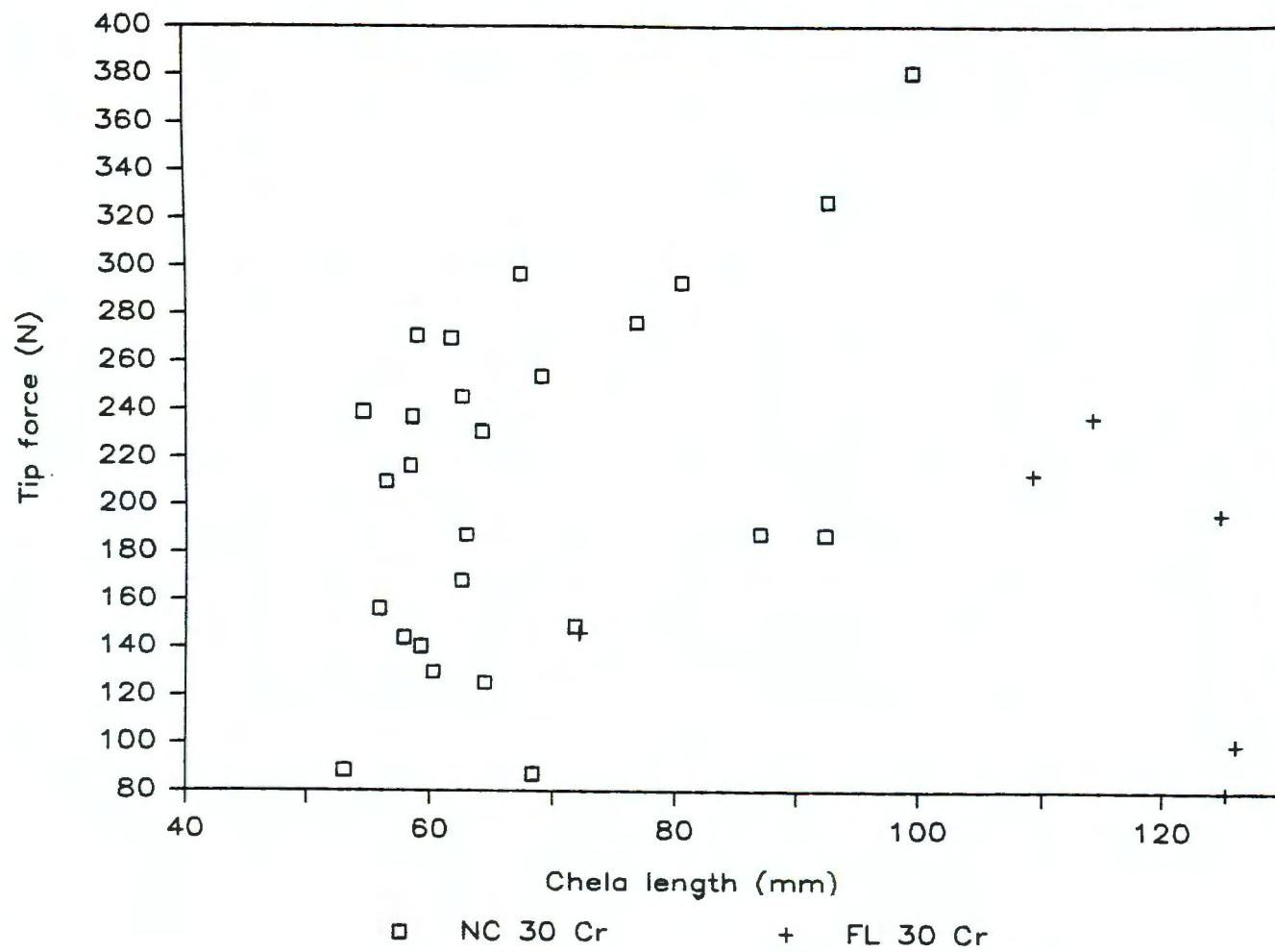

Figure 7. Dactyl tip force as a function of chela length for temperate (NC) and tropical (FL) warm acclimated M. mercenaria crusher chelae (30°C). Regression equation for NC crusher chelae:  $y \text{ (N)} = 2.84x \text{ (mm)} + 19.12$ ,  $r^2 = 0.248$ ,  $n = 26$ , ( $P < 0.05$ ). No significant regression for FL crusher chelae ( $P > 0.05$ )





## DISCUSSION

Observations by Vermeij (1977) of the distributions and morphologies of many decapod genera suggest that tropical decapods may experience greater selection to increase chela strength. I chose to test this hypothesis within a decapod species that is latitudinally distributed from the temperate region to the tropics. I must reject the hypothesis that tropical Menippe mercenaria are stronger than their temperate conspecifics. Chela morphology of the two populations are not significantly different. When the populations are tested at summer temperatures common to both, I found no differences in muscle stresses generated by the chelae.

Chela morphology

Relative chela and muscle size, mechanical advantage, and angle of pinnation were all similar for temperate and tropical populations of M. mercenaria. I can only assume that there are no temperature limitations to the development and maintenance of large chela in temperate waters, and that if there is any selection to increase fighting ability in the tropical population of M. mercenaria, it has no noticeable effect on chela morphology.

Sexual dimorphism in chela size relative to carapace width has been noted in faster, aggressive crab species (e.g. Callinectes, Cancer, and Menippe) but not in more sluggish ones (e.g. Carpilius, Lydia, Daldorfia horrida) (Vermeij, 1977). Perhaps males of the dimorphic species do most of the fighting (Warner, 1970).

Mechanical advantage of chelae as I have measured it is only relevant in comparing one chela to another or when the tip of the dactyl is used to apply force. Actual values of mechanical advantage are often higher when the crab uses dentition along the dactyl more proximal to the tip to apply force. Quite often the large molars of the crusher,

located most distally along the dactyl, are used while cracking prey. Here the mechanical advantage often approaches 1.

Angles of pinnation were only measured along the dorsal surface of the chela closer muscle. Warner et alia (1982) sampled ventral as well as distal fibers in the closer muscle of Carcinus maenas chela and found no differences in angles of pinnation between fiber layers. They also found differences in angle along the distal-proximal axis of the muscle similar to that in M. mercenaria.

### Chela closer muscle performance

Techniques of stress measurement. The maximum value of muscle stress recorded from stone crabs (220 N/cm<sup>2</sup> at 30°C) is above those reported for other Crustacea and much greater than the average stress generated for vertebrate muscles. Maximum values for crustacean fibers (some of which have a sarcomere length of 9 to 14  $\mu$ m) are 72.1 N/cm<sup>2</sup> for Cancer pagurus at 15°C (evoking contraction with high K<sup>+</sup> plus caffeine injection, Warner and Jones, 1976), 105.7 N/cm<sup>2</sup> for Carcinus maenas at 10 to 15°C (suprathreshold axonal stimulation, Warner et alia, 1982), and 43.0 N/cm<sup>2</sup> for Homarus americanus at 11 to 14°C (force required to pull a closed chela open using a spring balance, Elner and Campbell, 1981). Vertebrate muscles (with sarcomere lengths of 2 to 3  $\mu$ m) consistently show stress values of approximately 20 N/cm<sup>2</sup> (Prosser, 1973).

Stress measurements are typically recorded from in vitro preparations using either nervous stimulation or potassium depolarization. Warner et alia (1982) concede that this latter method is inferior to axonal stimulation measurements in Crustacea. I have never had success in measuring the same forces in an autotomized chela with suprathreshold axonal stimulation at maximum frequency as I have had with using the gripping force transducer and live whole crabs. Usually when stimulating the axons of a



chela, muscle tension rises to a peak within 1 to 2 seconds, maintains tension for several seconds, and then fatigues. This is not the response given by live crabs. Perhaps their initial enthusiastic maximum peak in tension is generated by a more complex frequency pattern of innervation. Also, my experience with other methods of taking measurements from live crabs (e.g. with their chela fixed in a clamp and pulled open by a spring balance) leads me to believe that restricting crabs in any manner at all usually results in a less than full response. This latter type of measurement seems to encourage the crab to increase its tension slowly as tension on the spring balance is gradually increased. The muscle may already have begun to weaken by the time the spring balance pulls the dactyl open.

Crabs from both populations and temperature extremes typically applied maximum forces to the transducer for less than a second, followed by a sustained contraction for several seconds that was 50 to 75 % of maximum stress. I have seen similar behavior while watching stone crabs feeding on oysters. The crabs often held oysters in their crusher chela, using the cutter chela for assistance, while applying short bursts of force. If this failed to crack the oyster, the crab manipulated the oyster in search of a weak spot until successful breakage occurred. Forces required to crack oysters (75 - 110 g wet weight) outright as recorded on the Instron machine ranged from 1.2 to 2.5 kN. This was well above forces generated anywhere along stone crab dactyls. Applying sublethal forces may progressively weaken the shell. Descriptions of similar feeding behaviors and quantifications of force generation have been reported in other Crustacea (by Elner and Campbell, 1981, for Homarus americanus and by Boulding, 1984, for Cancer productus) by attaching strain gauges directly to chelae.

If the force transducer had been improperly calibrated, muscle stress values could become exaggerated. I

feel the differences in stress data recorded with my technique and those of others are more likely due to technique differences and not due to measurement error. Calibration of the transducer in the field was done with only one known force (a 60 N weight). However, using the Instron machine to apply forces to the transducer from 50 to 700 N, the response of the pressure gauge on the transducer was both linear and precise (regression coefficient of determination = 0.999 for transducer response as a function of load).

Patterns of stress within and among chela types.

Force generated by a muscle fiber is proportional to sarcomere length (Huxley and Niedergerke, 1954). It is not surprising to find that muscle stress is several times greater in Crustacea with very long sarcomere lengths relative to vertebrates. The higher ratio of actin to myosin filaments in crustacean fibers may enhance force as well (Warner and Jones, 1976).

In vertebrates, muscle stress is not related to muscle size. Muscle stress in a 7 kg kangaroo was similar to that in a 2500 kg elephant (Alexander et alia, 1979). The actual relationship of muscle stress and chela size in stone crabs may have been confounded by the fact that resting lengths of muscle fibers during testing varied with chela size. Given that the distance between the two force transducer bars was approximately 15 mm, small crabs had to open their chela to a greater degree in order to grasp the transducer. I tested the relationship between chela gape and muscle stress in an autotomized chela. Stress was reduced approximately 30 % when the chela was tested at an open angle of 20° relative to an open angle of 33°. This method must have also reduced the magnitude of forces generated at the dactyl of larger chela as well as values of muscle stress. Perhaps this is why dactyl tip force was not significantly related to chela size in Florida M. mercenaria, most of which were quite large (Figure 9).

There is not necessarily any biological significance



in choosing an exponential curve to predict chela strength as a function of size other than minimizing the sums of squares of differences between observed data and predicted values. However, the pattern of exponential decrease in muscle stress with chela size has been noted before in lobsters, where chela gape was similar in chelae of different sizes (autotomized chelae were tested in a half open position) (Elner and Campbell, 1981). Elner and Campbell speculated that decreased muscle stress in larger muscles may be due to increased amounts of vascular and connective tissue within larger muscles.

Similar values of muscle stress between M. mercenaria crusher and cutter chelae suggest that the closer muscles may not be asymmetric in fiber composition. Measurements of sarcomere length in M. mercenaria cutter and crusher closer muscles showed that both are composed primarily of slow tonic muscle fibers measuring 12 to 14  $\mu\text{m}$  (P. J. Stephens, personal communication). Blue crab (Callinectes sapidus) crushers and cutters both produce muscle stress values of approximately 50 to 60  $\text{N}/\text{cm}^2$  and are composed primarily of muscle fibers with sarcomere lengths of approximately 10 to 11  $\mu\text{m}$  (Govind and Blundon, 1985). Adult lobster chela closer muscles are quite asymmetric in fiber composition, and this is reflected in muscle stress measurements. The cutter closer muscle is composed of approximately 70 % fast phasic fibers and 30 % slow tonic fibers, while the crusher is nearly 100 % slow tonic fibers (Govind, 1984). Dactyl force measurements are 5 to 10 times greater in the crusher, and muscle stresses are 2 to 3 times greater in the crusher (Blundon, unpublished).

Latitudinal comparisons of muscle stress. As was found for chela morphology, muscle stress was similar between the temperate and tropical populations of M. mercenaria. Any selection to increase chela strength should almost certainly be seen at this level, because crustacean muscle fiber development and condition seem so readily influenced by

exercise (Abby-Kalio and Warner, 1984; Govind and Pearce, 1986). Yet no such differences were seen in fiber performance.

No research has been done to test the idea that there might be greater competition and/or predation amongst decapods in the tropical extreme of the species' range. The only other possible threat to M. mercenaria in terms of size and strength is M. nodifrons, which was infrequently seen in Florida and does not extend to North Carolina. Tropical Callinectes species possess relatively larger chelae than temperate C. sapidus. However, C. sapidus, which extends from New England to Florida, shows no latitudinal differences in morphology (Vermeij, 1977).

Although mollusc prey are probably much more calcified in the tropics, the possibility that increased prey armament may reciprocally give rise to stronger predators may be of limited importance (Vermeij, 1982). Selective forces imposed by prey that do not harm their predators are weak; failure of a predator to consume its prey merely costs a small amount of time and energy. A predator may ultimately switch diets to a more accessible prey item. Much stronger selection may be imposed on decapods by their enemies; failure to escape a predator often results in death.

The possibility exists that crabs which reduce feeding (and hence chela closer muscle use) in cooler temperatures may suffer seasonal losses in muscle stress. Muscle tension and sarcomere length were significantly reduced in Carcinus maenas that were fed soft food for six months (Abby-Kalio and Warner, 1984). On the other hand, if a crab that exists in a eurythermic (e.g. temperate) environment is fully functional at all temperature ranges, it would be interesting to determine if a conspecific living in a stenothermic (tropical) environment has lost the capacity to function outside its range of temperature experience.

Chapter 2 describes how both temperate and tropical

populations of M. mercenaria perform at cold temperatures normally experienced only by the temperate population. It also reports the acclimation abilities of both populations in the laboratory.



## REFERENCES

- Abby-Kalio, N. J. and G. F. Warner, 1984. Effects of two different feeding regimes on the chela closer muscles of the shore crab Carcinus maenas (L.). Mar. Behav. Physiol. 11:209-218.
- Alexander, R. McN., 1968. Animal mechanics. University of Washington Press, Seattle, Washington, 346 pp.
- Alexander, R. McN., 1969. Mechanics of the feeding action of a cyprinid fish. J. Zool., Lond. 159:1-15.
- Alexander, R. McN., G. M. O. Maloij, B. Hunter, A. S. Jayes, and J. Nturibi, 1979. Mechanical stresses in fast locomotion of buffalo (Syncerus caffer) and elephant (Loxodonta africana). J. Zool., Lond. 189:135-144.
- Boulding, E. G., 1984. Crab-resistant features of shells of burrowing bivalves: Decreasing vulnerability by increasing handling time. J. Exp. Mar. Biol. Ecol. 76:201-223.
- Brown, S. C., S. R. Cassuto, and R. W. Loos, 1979. Biomechanics of chelipeds in some decapod crustaceans. J. Zool., Lond. 188:143-159.
- Clarke, M. R. B., 1980. The reduced major axis of a bivariate sample. Biometry 67:441-446.
- Elner, R. W. and A. Campbell, 1981. Force, function and mechanical advantage in the chelae of the American lobster Homarus americanus (Decapoda: Crustacea). J. Zool., Lond. 193:269-286.
- Govind, C. K. and J. A. Blundon, 1985. Form and function of the asymmetric chelae in blue crabs with normal and reversed handedness. Biol. Bull. 168:321-331.
- Govind, C. K. and J. Pearce, 1986. Differential reflex activity determines claw and closer muscle asymmetry in developing lobsters. Science 233:354-356.
- Huxley, A. F. and R. Niedergerke, 1954. Structural changes in muscle during contraction. Interference



microscopy of living muscle fibres. Nature 173:971-973.

Pianka, E. R., 1966. Latitudinal gradients in species diversity: a review of concepts. Amer. Nat. 100:33-46.

Prosser, C. L., 1973. Comparative animal physiology, 3rd edition. W. B. Saunders and Company, Philadelphia, Pennsylvania, 966 pp.

Revelle, A. and R. Fairbridge, 1957. Carbonates and carbon dioxide. Geol. Soc. Amer. Mem. 67:239-296.

Ricker, W. E., 1973. Linear regressions in fishery research. J. Fish. 30:409-434.

Snedecor, G. W., 1956. Statistical methods applied to experiments in agriculture and biology, 5th edition. Iowa State College Press, Ames, Iowa, 534 pp.

Sokal, R. R. and F. J. Rohlf, 1969. Biometry. W. H. Freeman and Company, San Francisco, California, 776 pp.

Vermeij, G. J., 1976. Interoceanic differences in vulnerability of shelled prey to crab predation. Nature 260:135-136.

Vermeij, G. J., 1977. Patterns in crab claw size: the geography of crushing. Syst. Zool. 26:138-151.

Vermeij, G. J., 1978. Biogeography and adaptation. Harvard University Press, Cambridge, Massachusetts, 332 pp.

Vermeij, G. J., 1982. Unsuccessful predation and evolution. Amer. Nat. 120:701-720.

Warner, G. F., 1970. Behaviour of two species of grapsid crab during intraspecific encounters. Behav. 36: 9-19.

Warner, G. F. and A. R. Jones, 1976. Leverage and muscle type in crab chelae (Crustacea: Brachyura). J. Zool., Lond. 180:57-68.

Warner, G. F., D. Chapman, N. Hawkey, and D. G. Waring, 1982. Structure and function of the chelae and chela closer muscles of the shore crab Carcinus maenas (Crustacea: Brachyura). J. Zool., Lond. 196:431-438.

Williams, A. B., 1984. Shrimps, lobsters, and crabs of the Atlantic coast of the eastern United States, Maine

to Florida. Smithsonian Institution Press, Washington,  
D.C., 550 pp.

## CHAPTER 2

Effects of temperature on neuromuscular properties  
of chelae of temperate and tropical stone crabs  
Menippe mercenaria (Say)

## INTRODUCTION

The stone crab Menippe mercenaria (Say) is a decapod crustacean found in temperate waters as far north as North Carolina as well as in the tropics (Williams, 1984). Is it possible that the different temperature regimes experienced by the two populations have resulted in physiologically distinct populations? This question was addressed in the present study by examining the active and passive properties of the neuromuscular system and the behavior of live M. mercenaria in the field. Comparisons were made among temperate and tropical crabs in the field and in the laboratory at summer temperatures. Performance of both populations was also examined by acclimating them to the winter temperatures of the temperate population in the laboratory. A more natural acclimation regime was accomplished by collecting crabs from both populations during the summer, transplanting the tropical ones to temperate waters, and then examining them in the winter.

Ectothermic animals that experience large short term fluctuations in temperature are often able to maintain some degree of homeothermy through a variety of mechanisms. Many reptiles change color or bask in the sun to increase internal body temperature (Pearson, 1954). Insects may resort to shivering to create internal muscular heat or by restricting blood flow to the periphery (Heinrich, 1974). Ectotherms that are subjected to a wide difference in seasonal temperatures either become inactive during the colder periods or undergo biochemical changes in enzymes and/or cell membranes to compensate. The production of enzyme variants that work at different temperatures is in part the result of the phenotypic expression of genes that have been selected for in a eurythermic environment (Hochachka and Somero, 1984).

Because of the high heat capacity of water, aquatic animals are very limited in behavioral mechanisms to com-



pensate for reduced body temperature. Those that live in arctic or temperate oceans, estuaries or fresh water habitats may spend such a large part of the year in cold water that hibernation may not be feasible for survival. These animals therefore must remain functional throughout the wide thermal range encountered year round. Seasonal changes in enzyme production and in the lipid membrane (that interacts with enzymes and influences enzyme activity) have been described in fish (Baldwin and Hochachka, 1970; Hazel, 1972).

Many eurythermic Crustacea exhibit normal body movement and coordination over a wide range of temperatures (Harri and Florey, 1977, 1979; Fischer and Florey, 1981; Stephens and Atwood, 1982; White, 1983). Crayfish, Astacus leptodactylus, are able to move about from 0 to 30°C (Harri and Florey, 1977). The North American lobster, Homarus americanus, spends a major portion of its lifetime at water temperatures that are so cold (<10°C) that other Crustacea would cease feeding. Yet the lobster is able to use its chelae equally well in winter (4°C) as in summer (21°C) (Blundon, unpublished data).

The ability to function outside the usual temperature range may be limited in animals that live in relatively stenothermic tropical waters. The Hawaiian ghost crab, Ocyropsis ceratophthalma, rarely experiences temperatures outside the range of 26 to 28°C. Normal body activity is not possible below 23°C or above 30°C (Florey and Hoyle, 1976).

Results of this study showed that temperate and tropical populations of M. mercenaria have similar neuromuscular responses to changes in temperature. Tropical crabs transported to North Carolina and naturally acclimated to North Carolina winter temperatures showed similar levels of muscle stress and neuromuscular responses to stimulation compared to their temperate conspecifics. Both populations of crabs showed poor ability to acclimate to rapid de-



creases in temperature. This may be a reflection of their natural marine subtital environment, where sizable short term temperature fluctuations are uncommon.

## METHODS

Maintenance of animals

Temperate stone crabs were collected by hand from Beaufort, North Carolina. Water temperatures ranged from 2°C in January to 30°C in August (Duke University Marine Laboratory monitoring). Tropical crabs were caught in Marathon, Florida (Florida Keys) with lobster pots. Water temperatures here ranged from 21°C in January to 31°C in August (National Hurricane Service monitoring).

Each crab was maintained in artificial sea water (34 ppt salinity) in a small 10 gallon aquarium. Water was circulated with a magnetic drive pump from a 55 gallon reservoir through a PVC pipe loop that had a faucet above each small aquarium. A drain hole in the side of each small aquarium allowed water to return to the reservoir where filtration and heating or cooling occurred. A light:dark cycle of 12 hours:12 hours was maintained in the aquarium rooms. Winter crabs were placed in 8°C water upon arrival; summer crabs were placed in 30°C water. Crabs were fed oysters which were readily cracked and eaten.

Temperature treatments

In the laboratory, summer crabs were subjected to rapid cold acclimation (since it occurs much quicker than the natural 4 to 5 month temperature decrease) by changing water temperature from 30 to 8°C over a three week period. The animals were then allowed 4 weeks to acclimate to the new temperature.

Natural cold acclimation of summer animals to winter temperatures was accomplished by placing temperate and tropical stone crabs in outdoor sea water tanks at the Duke University Marine Laboratory (Beaufort, NC) in July and collecting them the following January. These sea water tanks were uncovered and exposed to natural light

conditions, and they received a continuous flow of sea water from Bogue Sound. Cinder blocks were placed in each of these tanks to provide adequate habitat. Crabs were regularly fed oysters.

#### Chela closer muscle performance in intact crabs

Muscle stress measurements were taken from both summer and winter crabs immediately upon collection. Chela force was measured using a force transducer described in Chapter 1. Force measurements were also recorded from summer animals subjected to rapid cold acclimation. These data were compared with force measurements taken from control summer animals that were maintained in laboratory for the same duration in 30°C water. Muscle stress values were calculated using chela measurements and formulae also described in Chapter 1.

Statistics to compare the functional relationships between muscle stress and chela size are described in Chapter 1. A one-way analysis of variance (ANOVA) was used to compare changes in mean muscle stress with temperature among various experimental treatments (natural versus rapid cold acclimation, temperate versus tropical). If the ANOVA was significant, differences in means were tested with a Student-Neuman-Keuls multiple test procedure. Homogeneity of variance was assured with Bartlett's test for homogeneity of variance (Sokal and Rohlf, 1969).

#### Measurements from autotomized crab chelae

Active neuromuscular properties. The chela closer muscle was exposed by removing the dorsal surface of the propus, the opener muscle, and tissue overlying the closer muscle. The chela was clamped in a plexiglas chamber with brass screws placed in the side of the chamber and was perfused with a physiological saline of 470 mM NaCl, 8 mM KCl, 7 mM MgCl<sub>2</sub>, 15 mM CaCl<sub>2</sub>, 11 mM glucose, and buffered with 5 mM HEPES to a pH of 7.4. The recording chamber was



suspended in a larger plexiglas chamber which contained either an ice bath or warm water bath to change and maintain saline temperature. Temperature of the preparation was changed by slowly perfusing with either 5°C or 30°C saline in addition to cooling or warming the bath temperature. The saline was frequently stirred to assure equal temperature throughout; temperature was monitored with a thermometer placed next to the closer muscle. Rate of cooling was approximately  $-0.4^{\circ}\text{C}/\text{minute}$ , and heating rate was approximately  $+0.8^{\circ}\text{C}/\text{minute}$ .

Axons innervating the muscle were isolated by breaking the joints between the merus and propus, cutting away all apodemes that attached to the propus, and gently sliding away all limb segments proximal to the propus. Motor axons were separated from the sensory afferent axons either by sight (the motor axons are smaller and more transparent than the sensory) or by stimulation. The motor axon bundle was placed across a pair of platinum hook electrodes.

Action potentials in the motor axon bundle were monitored with a suction electrode placed just proximal to where the bundle submerged into the closer muscle. This suction electrode was connected directly to a storage oscilloscope (Tektronix 502A). Resting membrane potentials (RMPs) and excitatory post-synaptic potentials (EPSPs) were monitored by inserting a glass microelectrode (10 to 30 M $\Omega$ , filled with 3 M KCl) into the dorsal fibers of the closer muscle. The microelectrode was connected to a high input impedance DC amplifier with capacity compensation, which was connected to the oscilloscope. Output from the amplifier was also recorded on a Brush 220 chart recorder (Gould, Inc.). The bath was grounded to the oscilloscope via a saline-agar-Ag/AgCl wire reference electrode. Junction potentials in the circuit of the recording electrode were balanced with a variable DC voltage source placed between the reference electrode and oscilloscope ground. Successful penetration into the muscle fiber was indicated

by a rapid drop in potential of  $-60$  mV or more (less at lower temperatures). Stimulation of the axon bundle was done with a Grass SD9 square wave stimulator (pulse duration 1.0 ms). The stimulus voltage was adjusted to excite only the fast closer excitatory axon, which usually had the lowest stimulus threshold. EPSPs evoked by the slow closer excitatory motor axon had a much smaller amplitude but would significantly alter muscle depolarization level and tension at higher frequencies ( $> 40$  Hz).

Facilitation of EPSPs was measured as the amplitude of EPSPs produced at 10 Hz (recorded after the muscle fiber has reached a plateau of depolarization) divided by the amplitude of a single EPSP. Amplitude of EPSPs cannot be directly compared unless they begin at the same level of membrane potential (i.e. they experience the same ionic driving force). The amplitude of an EPSP that sums with a preceding EPSP will be less given the same number of ionic channels opening because it is closer to its reversal potential and therefore experiencing a lower driving force. Martin (1955) provides a formula which compensates for non-linear summation when comparing EPSP amplitudes. Muscle fiber depolarization was measured as the plateau depolarization above the resting membrane potential when the muscle was stimulated axonally at 20 Hz.

Passive muscle fiber properties. Muscle fiber capacitance and resistance were measured by measuring muscle fiber membrane potential response to injected hyperpolarizing current at various measured distances from current injection. The stimulating electrode was a broken glass microelectrode (5 to 10 M $\Omega$ ) filled with 2 M potassium citrate; the recording electrode was a glass microelectrode (10 to 30 M $\Omega$ ) filled with 3 M KCl. Initially each electrode was connected to a high input impedance DC amplifier equipped with capacitance compensation which was connected to the oscilloscope. After successful penetration of the fiber with the stimulating electrode, this electrode was



then connected to a load independent constant current generator (Model 106, World Precision Instruments, Inc.) with an output resistance of  $> 100 \text{ M}\Omega$ . A hyperpolarizing current of  $1000 \text{ nA}$  was preset on the current generator. The current amplitude was checked by measuring the voltage drop across a  $10 \text{ k}\Omega$  resistor. The current pulse was triggered by a Grass SD9 stimulator and lasted for  $200 \text{ ms}$ , which was sufficient time for the capacitor of the membrane to become fully charged. Muscle fiber membrane potential response to hyperpolarizing current was measured at various distances between the stimulating and recording electrodes. Voltage responses monitored on the oscilloscope were also recorded with a chart recorder. The distance between electrodes as well as the diameter of the muscle fiber were measured with a calibrated ocular micrometer.

Membrane potential response versus distance from current source was plotted and fitted to the equation

$$V_x = V_0 e^{-x/\lambda}$$

using least squares regression analysis. Using this curve the potential response at distance = 0 ( $V_0$ ) was extrapolated and used to calculate muscle fiber membrane input resistance ( $r_{\text{input}}$ ). The space constant ( $\lambda$ ), which is the distance away from the current source that the voltage drops to  $1/e$  of  $V_0$ , depends on the muscle fiber membrane resistance  $r_m$  and the resistance of the fiber myoplasm  $r_i$  and follows the equation

$$\lambda = (r_m/r_i)^{-0.5}.$$

Since the current injected into the fiber spreads in both directions away from the stimulating electrode, the input resistance is related to the membrane resistance and myoplasm resistance by

$$r_{\text{input}} = 0.5(r_m r_i)^{-0.5}.$$

Calculations of  $r_m$  and  $r_i$  were possible with values for  $r_{\text{input}}$  and  $\lambda$ :

$$r_m = (r_{\text{input}})^2 \lambda \quad \text{and}$$

$$r_i = 2(r_{\text{input}})/\lambda.$$

These measurements are dependent on fiber diameter ( $2a$ ). The specific membrane resistance  $R_m$  and specific myoplasm resistance  $R_i$  are independent of fiber geometry since they take into account fiber size and as such are comparable between cells. They are calculated as follows:

$$R_m = r_m(2\pi a) \quad \text{and}$$

$$R_i = r_i(\pi a^2)$$

Capacitance ( $C_m$ ) of the membrane is related to the membrane resistance by:

$$C_m = \tau/R_m$$

where  $\tau$  is the membrane time constant, the time it takes the potential to rise to  $1 - 1/e$  of its final value. I calculated  $\tau$  following a method used by Hodgkin and Rushton (1946) by plotting the time to reach  $1/2$  potential versus distance between stimulating and recording electrodes. The slope of this line,  $b$ , is used directly in calculating  $\tau$ :

$$\tau = b^2\lambda$$

Differences in passive muscle fiber properties (mean membrane specific resistance, input resistance, space constant, time constant and capacitance) among populations and temperature treatments were tested with a one-way analysis of variance. If the ANOVA was significant, a Student-Neuman-Keuls multiple comparison procedure determined which means were significantly different (Sokal and Rohlf, 1969).

To standardize the changes in fiber passive properties, I chose to present the data in terms of a change per  $-10^\circ\text{C}$ . In other words, I recorded the data at 8 and  $30^\circ\text{C}$  and calculated the change per  $-10^\circ\text{C}$  by:

$$(\text{value @ } 8^\circ\text{C} / \text{value @ } 30^\circ\text{C})^{10/22}$$

This is the formula for calculation of  $Q_{10}$ s, but my measurements are not rates and cannot be considered  $Q_{10}$ s.



## RESULTS

Chela closer muscle stress measurements from intact crabs

Both temperate and tropical crabs held in the laboratory at 30°C for 7 weeks showed no significant change in muscle stress compared to pre-treatment measurements. Rapid cold acclimation resulted in a significant 60 % decrease in muscle stress for both temperate and tropical crabs (Table III).

Results from field measurements suggest that the large reduction in strength found in both temperate and tropical rapid cold acclimated crabs may be an artifact of the speed of water temperature change or the duration of the acclimation. Temperate summer and winter crabs showed no differences in muscle stress (Figure 8). Muscle stress was best predicted by a negative exponential relationship with chela length.

In July 1985, I placed twelve stone crabs from Beaufort, North Carolina and twelve from Marathon, Florida in outdoor sea water tanks located in Beaufort, North Carolina at the Duke University Marine Laboratory. Chela measurements were recorded at that time and were again recorded the following January. I refer to these animals as natural cold acclimated crabs. Muscle performance in natural cold acclimated crabs was significantly greater than in crabs given rapid cold acclimation. However, both groups of natural cold acclimated crabs (temperate and tropical) showed 30 % less strength compared to their measurements made the previous July (Table III).

Measurements from autotomized crab chelae

Active properties. Fibers from both rapid cold and natural cold acclimated temperate crabs showed similar changes in the resting membrane potential (RMP) as bath temperature was changed. Cooling from 30 to 8°C resulted in a depolarization of the RMP of approximately 15 mV. A

Table III. Muscle stress of M. mercenaria crusher chelae at various temperature treatments. Means are percentages of pre-treatment values. SEM = standard error of means, n = sample size, ns = not significant, \* =  $P < 0.05$ , \*\*\* =  $P < 0.01$



## LABORATORY MEASUREMENTS OF CHELA CLOSER MUSCLE STRESS

Treatment	% muscle stress after treatment mean $\pm$ SEM (n)	compared to 100 %
NC rapid cold	37.8 $\pm$ 7.87 (5)	***
NC warm	109.0 $\pm$ 14.25 (7)	ns
FL rapid cold	39.9 $\pm$ 4.60 (6)	***
FL warm	94.5 $\pm$ 7.98 (4)	ns
NC natural cold	72.6 $\pm$ 10.66 (4)	*
FL natural cold	69.9 $\pm$ 9.20 (4)	*

Figure 8. Muscle stress as a function of chela length in summer (30) and winter (8) temperate M. mercenaria crusher chelae. NC 30:  $\ln y = -0.028x + 6.532$ ,  $r^2 = 0.528$ ,  $n = 27$ . NC 8:  $\ln y = -0.020x + 5.767$ ,  $r^2 = 0.698$ ,  $n = 19$ . No significant differences in either slopes or elevations ( $P > 0.05$ )

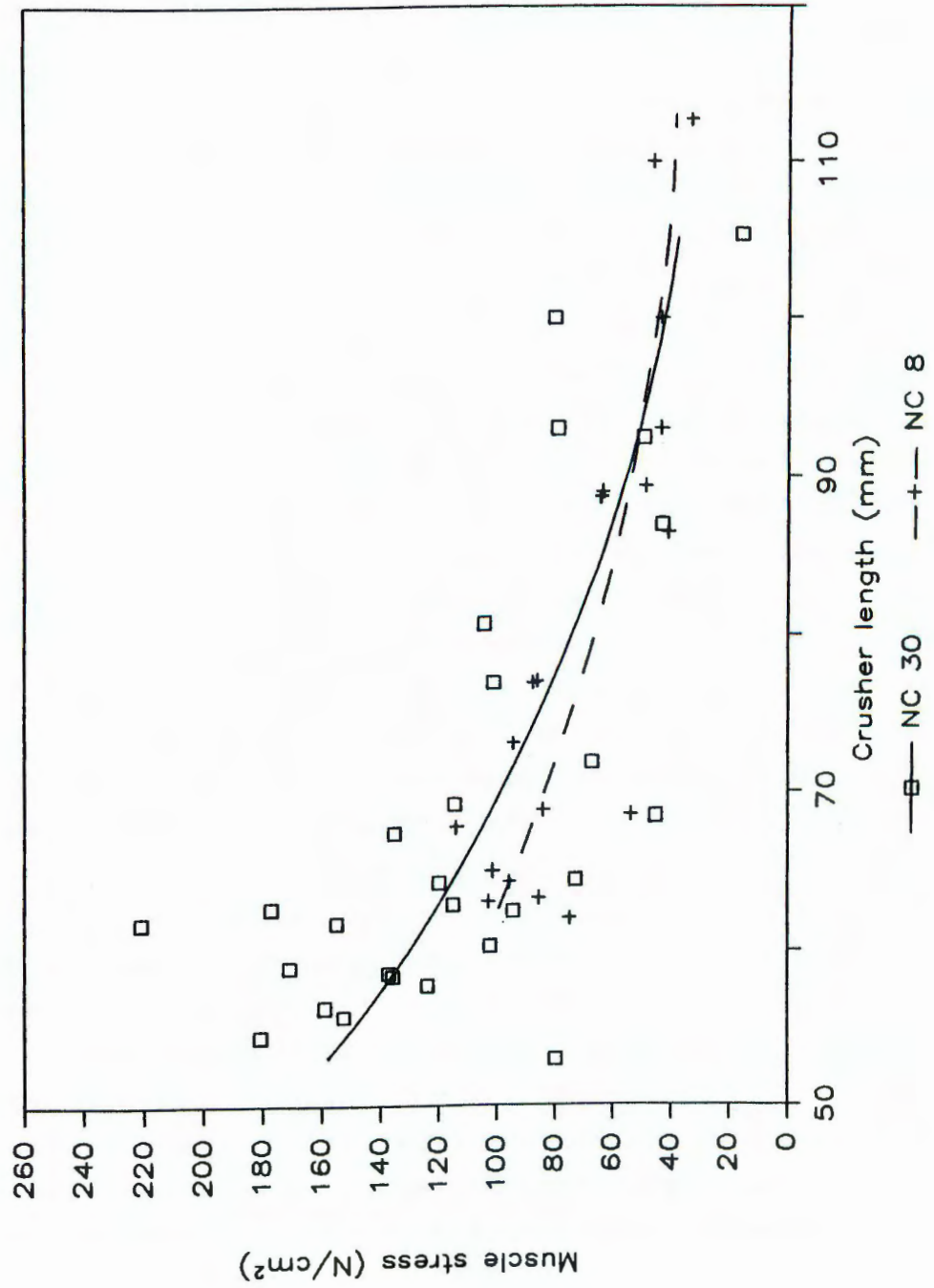

Similar level of hyperpolarization was recorded if the bath was warmed from 8 to 30°C (Table IV).

Excitatory post-synaptic potential (EPSP) amplitude in natural cold acclimated muscle fibers was similar at 8 and 30°C, although it was significantly larger at 20°C (to a mean of 2.7 mV). Rapid cold acclimation fibers also showed greater EPSP amplitude at 20°C (mean 8.8 mV), although EPSP amplitude was significantly greater at 8°C than at 30°C (Table IV).

There were no differences in facilitation between the rapid cold and natural cold acclimated fast closer excitatory axons when stimulated at 10 Hz. Both groups showed similar levels of facilitation for either 8 or 30°C. Levels of facilitation nearly doubled at 30°C relative to those at 8°C (Table IV). Levels of fiber depolarization with 20 Hz stimulation were also similar at the two temperature extremes (Table IV), even though the rapid cold acclimated fibers showed a greater EPSP amplitude at 8°C than natural cold acclimated fibers.

Summation of EPSPs at 8°C in natural cold acclimated fibers was much greater than in the rapid cold acclimated fibers. This was seen in the ratio of muscle fiber depolarization level to single EPSP amplitude (Table V) and in EPSP chart records (Figure 9). This ratio was significantly greater for natural cold acclimation crabs at 8°C at a frequency of axonal stimulation of 20 Hz. Differences of means of summation ratios between treatment groups are not significant at 30°C.

Passive properties. Chela closer muscle fibers from both natural cold acclimated temperate and tropical crabs showed similar levels of specific membrane resistance at 30°C and at 8°C. There was a significant increase in resistance in these two groups when cooled from 30 to 8°C. This was not seen in chela closer muscle fibers from temperate rapid cold acclimated crabs. Levels of specific membrane resistance were similar to the other two treatment



Table IV. Means of neuromuscular properties of muscle fibers in the chela closer muscles of M. mercenaria of various acclimation treatments and preparation temperatures. SEM = standard error of means, n = sample size, RMP = resting membrane potential, EPSP = excitatory post-synaptic potential

COMPARISONS OF NEUROMUSCULAR PROPERTIES  
Mean  $\pm$  SEM (n)

	<u>8°C</u>	<u>30°C</u>
<u>RMP (mV)</u>		
Rapid cold	<sup>a</sup> -61.8 $\pm$ 1.55 (12)	<sup>b</sup> -76.7 $\pm$ 1.90 (12)
Natural cold	<sup>a</sup> -61.3 $\pm$ 1.57 (16)	<sup>b</sup> -76.6 $\pm$ 1.64 (16)
<u>EPSP amplitude (mV)</u>		
Rapid cold	<sup>c</sup> 5.4 $\pm$ 1.37 (5)	<sup>d</sup> 2.3 $\pm$ 0.85 (5)
Natural cold	<sup>d</sup> 1.9 $\pm$ 0.48 (9)	<sup>d</sup> 1.1 $\pm$ 0.22 (9)
<u>Facilitation</u>		
Rapid cold	<sup>e</sup> 1.24 $\pm$ 0.147 (5)	<sup>f</sup> 2.54 $\pm$ 0.408 (5)
Natural cold	<sup>e</sup> 1.40 $\pm$ 0.088 (9)	<sup>f</sup> 2.68 $\pm$ 0.444 (9)
<u>Fiber depolarization (mV above RMP @ 20 Hz)</u>		
Rapid cold	<sup>g</sup> 9.4 $\pm$ 1.96 (5)	<sup>g</sup> 6.8 $\pm$ 1.95 (5)
Natural cold	<sup>g</sup> 7.9 $\pm$ 1.77 (9)	<sup>g</sup> 4.2 $\pm$ 0.93 (9)

a-g

superscripts with at least one letter in common denote no significant differences between means ( $P > 0.05$ )

Table V. Levels of EPSP summation as calculated by EPSP plateau amplitude @ 20 Hz / EPSP amplitude @ 1 Hz. SEM = standard error of means, n = sample size

RATIOS OF MUSCLE FIBER DEPOLARIZATION  
 20 Hz / 1 Hz  
 Mean  $\pm$  SEM (n)

	<u>Rapid cold</u>	<u>Natural cold</u>
<u>8°C bath</u>	<sup>a</sup> 2.0 $\pm$ 0.31 (5)	<sup>b</sup> 4.7 $\pm$ 0.85 (4)
<u>30°C bath</u>	<sup>a</sup> 3.8 $\pm$ 0.70 (5)	<sup>a</sup> 4.3 $\pm$ 0.62 (9)

a, b

similar superscripts within rows denote no  
 significant difference between means ( $P > 0.05$ )



Figure 9. EPSPs evoked by stimulation at 5, 10 and 20 Hz (for each bath temperature of 8 and 30°C) from chela muscle fibers of natural cold acclimated (A) and rapid cold acclimated (B) M. mercenaria. Horizontal scale = 500 ms, vertical scale = 5 mV

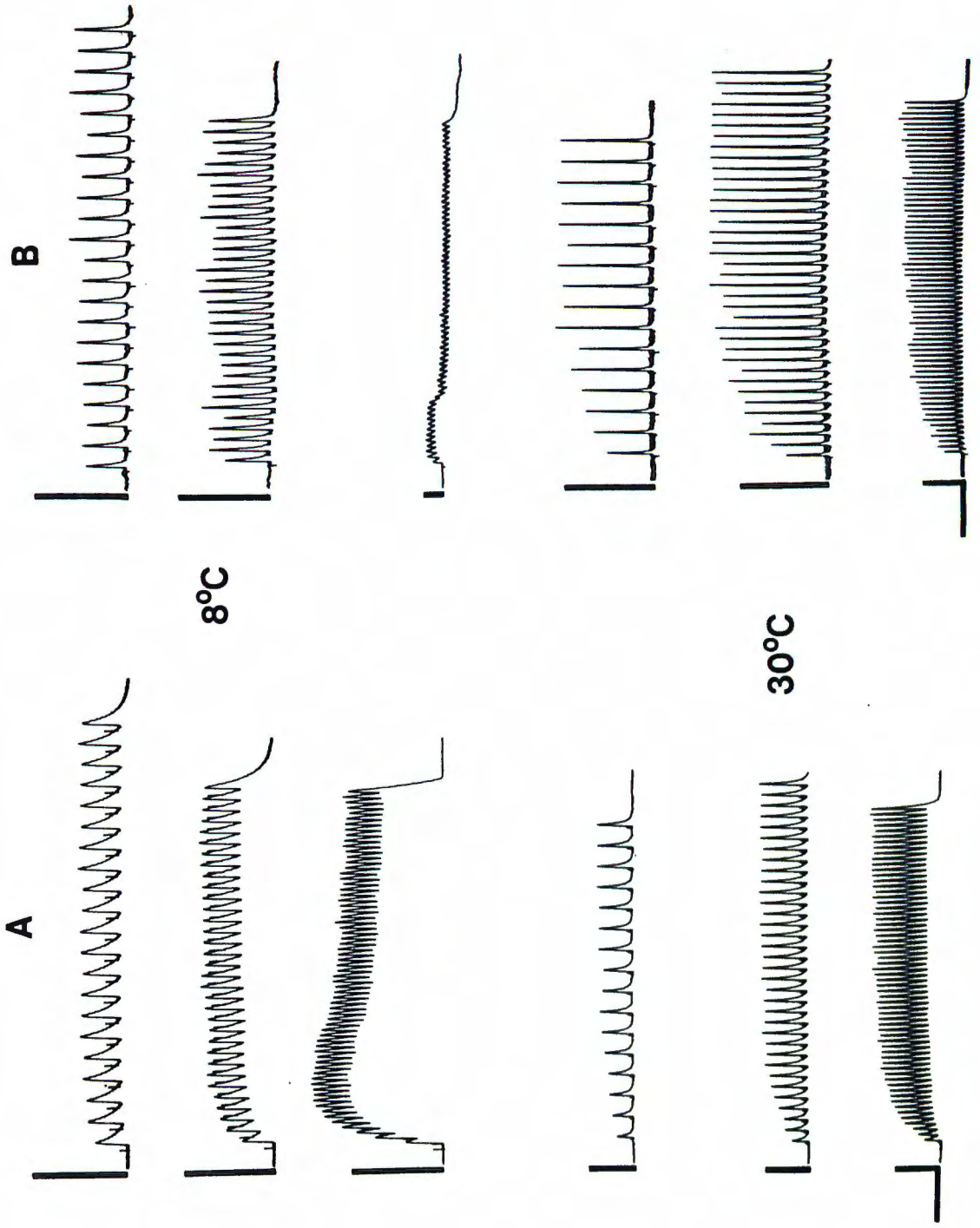

groups at 30°C, but in rapid cold acclimated fibers, resistance did not change when cooled to 8°C (Figure 10, Table VI).

A more detailed inspection of changes in passive properties showed that increases in specific membrane resistance in natural cold acclimated muscle fibers at cold temperatures were due to a combination of increases in both the space constant and fiber input resistance. The space constant was significantly greater in the tropical natural fibers when compared to the temperate rapid cold and natural cold acclimated fibers. The input resistance of the rapid cold acclimated fibers was significantly less than that of the natural cold acclimated fibers. The tropical natural cold acclimated fibers showed the highest degree of change in input resistance with cooling. The very small change in either space constant or input resistance with cooling in temperate rapid cold acclimated fibers resulted in similar values of specific membrane resistance at the two temperature extremes (Table VI). Although the time constant increased with cooling for all treatments (albeit significantly less for temperate rapid cold acclimated ones, Table VI), muscle fiber membrane capacitance was similar for all four treatment groups (Table VI).

Figure 10. Means (+ 1 standard error) of specific membrane resistance of chela closer muscle fibers from temperate (NC) and tropical (FL) rapid cold and natural cold acclimated M. mercenaria as a function of bath temperature. x denotes significant difference from values without x



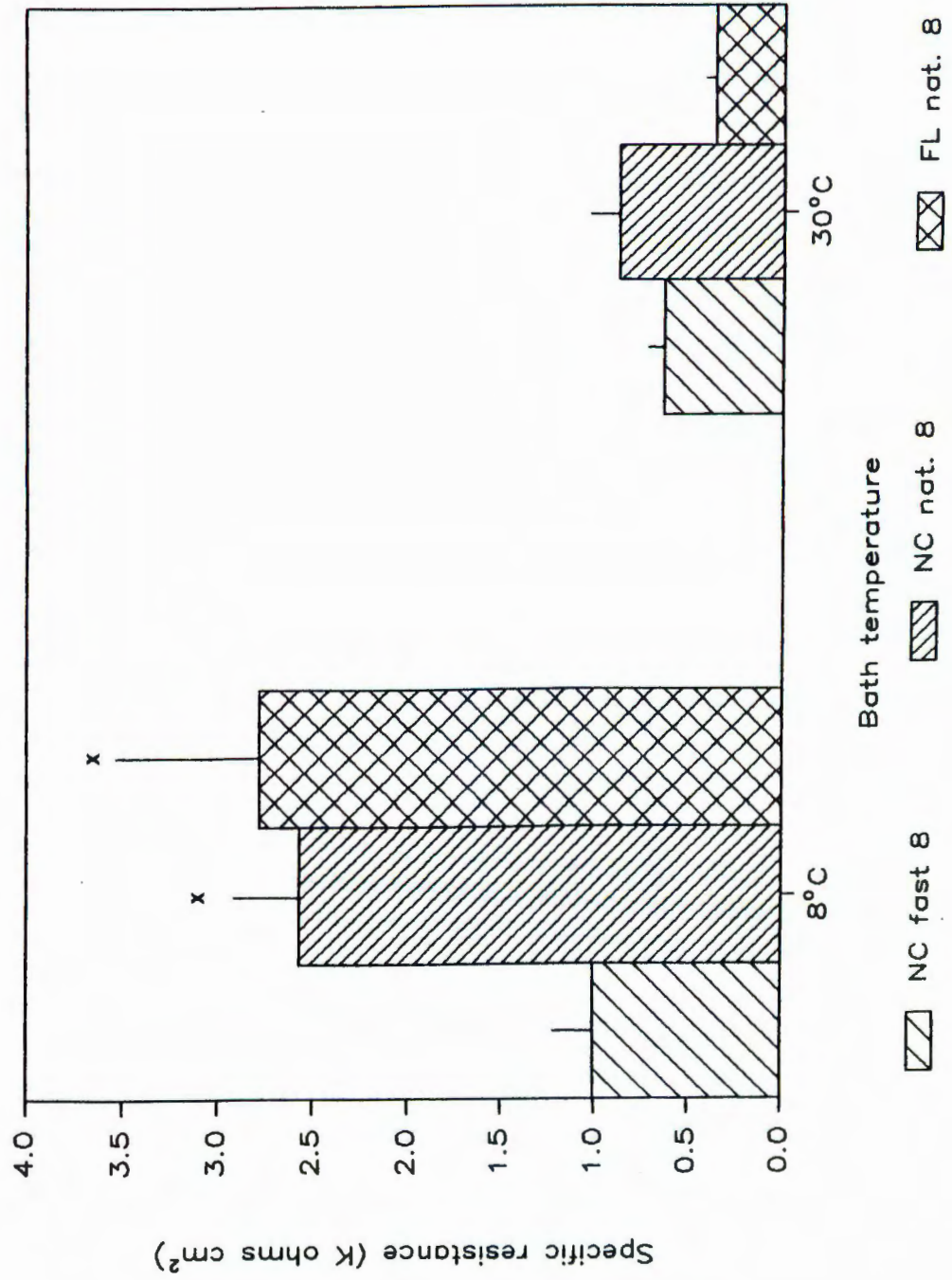

Table VI. Temperature associated changes in passive properties of muscle fibers of temperate (NC) and tropical (FL) rapid cold and natural cold acclimated M. mercenaria chelae. Values are the amount of change in a given property for  $-10^{\circ}\text{C}$ , measured from  $30$  to  $8^{\circ}\text{C}$ . SEM = standard error of means,  $n$  = sample size

AMOUNT OF CHANGE FOR 10°C COOLING  
Mean  $\pm$  SEM (n)

	<u>NC rapid cold</u>	<u>NC natural cold</u>	<u>FL natural cold</u>
space constant	a 1.02 $\pm$ 0.078 (7)	a 1.12 $\pm$ 0.059 (8)	b 1.59 $\pm$ 0.175 (4)
specific resistance	a 1.23 $\pm$ 0.111 (7)	b 1.66 $\pm$ 0.121 (8)	b 2.46 $\pm$ 0.277 (4)
input resistance	a 1.18 $\pm$ 0.070 (7)	b 1.47 $\pm$ 0.057 (8)	c 1.55 $\pm$ 0.024 (4)
time constant	a 1.42 $\pm$ 0.168 (7)	a 1.51 $\pm$ 0.091 (8)	b 2.83 $\pm$ 0.666 (4)

a-e

similar superscripts within rows denote no significant difference between means (P > 0.05)

## DISCUSSION

The objective of this study was to investigate the effects of short and long term temperature changes on neurophysiological properties of a species that has populations in both temperate and tropical regions. Results suggest that the stenothermic environment of tropical Menippe mercenaria has not restricted the ability of the crab's neuromuscular system to function outside its usual temperature range.

Chela performance among latitudinally separated populations of M. mercenaria exhibits no evidence of thermal specialization. Tropical stone crabs that were transplanted to North Carolina in summer and examined in the winter showed similar levels of chela performance when compared to temperate stone crabs treated in a similar manner. Although the tropical population lives in a relatively stenothermic environment, it has the capacity to function outside the range of its local thermal experience. The ability of a species to function in eurythermic environments is particularly essential in the successful distribution across latitudinal gradients.

Temperature independence of neuromuscular performance has been demonstrated in crayfish Procambarus clarkii (White, 1983) and Astacus leptodactylus (Harri and Florey, 1977, 1979; Fischer and Florey, 1981) as well as in the shore crab Pachygrapsus crassipes (Stephens and Atwood, 1982). Changes in active and passive neuromuscular properties in Menippe mercenaria chela closer muscles are similar to changes in these Crustacea.

The degree of fiber depolarization necessary to evoke contraction (the excitation-contraction coupling level or  $E_m$ ) is independent of temperature in crayfish (Dudel and Rudel, 1968). In this and other studies, lowering preparation temperature resulted in a depolarization of the resting membrane potential of muscle fibers, which lowered the



amount of fiber depolarization necessary for muscle contraction. Lowering temperature also increased muscle fiber membrane resistance, space constant and time constant. This resulted in a broadening of single EPSPs which led to enhanced EPSP summation and muscle fiber depolarization and contraction at lower temperatures.

#### Neuromuscular function at cold temperatures

Active properties. Resting membrane potentials in both rapid cold and natural cold acclimation muscle fibers became more depolarized as temperature decreased, although the amounts of depolarization were greater than that predicted by the Nernst equation alone ( $-0.2 \text{ mV}/^{\circ}\text{C}$ ). Additional changes in the RMP may be associated with increases in  $\text{Na}^+$  permeability relative to  $\text{K}^+$  and/or  $\text{Cl}^-$  permeability at lower temperatures (Fischbarg, 1972) or a cold associated decrease in the action of the electrogenic  $\text{Na}^+/\text{K}^+$  pump in the muscle fiber membrane (Florey and Hoyle, 1976; Harri and Florey, 1977; White, 1983).

Peak EPSP amplitude at mid-range physiological temperatures has been reported for both cold and warm acclimated crayfish A. leptodactylus (Harri and Florey, 1977, 1979), the Hawaiian ghost crab Ocypode ceratophthalma (Florey and Hoyle, 1976) and cold and warm acclimated shore crabs P. crassipes (Stephens and Atwood, 1982). In the above studies that compared animals from different acclimation treatments (all but Florey and Hoyle, 1976), cold acclimation had the effect of lowering the temperature of peak EPSP amplitude. Others have reported maximum EPSP amplitude at the lowest temperatures ( $2^{\circ}\text{C}$ ) (Fischer and Florey, 1981; White, 1983). In both these cases the crayfish studied had been acclimated to  $10^{\circ}\text{C}$ .

Decreases in EPSP amplitude at higher physiological temperatures may be the result of decreased muscle fiber membrane resistance that has been measured in this study and most of the above studies. Decreased responses to

iontophoresed neurotransmitter at lower temperatures in crayfish muscle (White, 1983) and frog muscle (Jensen, 1972) indicate that post-synaptic receptivity may be reduced at these low temperatures. Jensen (1972) also noted the reduction of miniature end-plate potential amplitude at low temperatures. Cold acclimation may in some cases lessen the decrease in post-synaptic receptivity (Fischer and Florey, 1981; White, 1983). Changes in the pre-synaptic terminal at lower temperature have been noted in the squid giant synapse by Charlton and Atwood (1979). In their study, inward calcium current evoked by terminal depolarization decreased at low temperatures, resulting in a decreased EPSP amplitude.

Passive properties. Changes in the time course of single EPSPs may be due to changes in neurotransmitter reactivity with post-synaptic receptors as well as changes in passive membrane properties such as capacitance and resistance. Fischer and Florey (1981) showed that changes in the decay time of EPSPs in crayfish muscle fibers paralleled changes in the decay time of membrane potential responses to injected current, and that no changes in neurotransmitter action needed be postulated to explain changes in EPSP duration. I quantified the level of EPSP summation by dividing total fiber depolarization by single EPSP amplitude. Summation at 8°C was significantly greater in natural cold acclimation muscle fibers (those that increase  $R_m$  at 8°C). Summation in cold acclimated A. leptodactylus was much greater compared to warm acclimated animals (as calculated by plateau depolarization at 10 Hz divided by single EPSP amplitude from Harri and Florey, 1979).

Changes in membrane resistance with temperature may be associated with temperature dependent changes in the resting membrane potential. White (1983) found decreased resistance in P. clarkii muscle fiber membranes at RMPs more negative than -90 mV. This rectification was evident in



the nonlinear current-voltage relationship measured from voltage responses to injection of hyperpolarizing current. He calculated that two thirds of changes in muscle fiber membrane resistance were due to this voltage sensitive rectification and the remaining changes in resistance might be accounted for by altered leak conductance of the membrane due to changes in the lipid membrane with temperature. In stone crab muscle fibers I found no evidence of rectification of hyperpolarizing current even at the most negative levels of RMP ( $-90$  mV). The current-voltage relationship remained linear throughout physiologically relevant levels of membrane potential. Current-voltage relationships were linear over a wide variety of membrane potentials in A. leptodactylus (Fischer and Florey, 1981). Changes I have measured in muscle fiber passive properties with temperature may be associated with changes in the muscle fiber lipid bilayer which could either affect integral proteins in the membrane (Hazel, 1972) such as ionic channels or alter the leakage of current across the membrane. Alternatively, ionic channel proteins could be modified during the natural acclimation process.

#### Neuromuscular function at warm temperatures

Although the RMP becomes hyperpolarized further from  $E_m$  at warm temperatures and EPSP amplitude and duration lessen, generation of tension is still possible. Facilitation of EPSPs increased significantly at warm temperatures (also found by Harri and Florey, 1977; Stephens and Atwood, 1983). Facilitation may occur to such a degree as to depolarize the muscle fiber membrane above  $E_m$  and thereby evoke contraction. Possible explanations of pre-synaptic facilitation include increasing  $Ca^{++}$  flux into the terminal with repeated stimulation, residual amounts of  $Ca^{++}$  within the terminal during subsequent terminal depolarization and  $Ca^{++}$  influx, recruitment of synaptic release zones during stimulation, and changes in  $Ca^{++}$  sequestering

organelles within the terminal (see Atwood, 1982 for review).

Another possible mechanism of temperature compensation of neuromuscular performance at warm temperatures has been put forth by Stephens (1985) for the shore crab P. crassipes. One of the two excitatory axons that innervates the bender muscle in a walking leg normally responds to stimulation with an action potential with a depolarizing after-potential. Warming the preparation had the result of increasing the amplitude of the after-potential. A bath temperature of 30°C enhanced the after-potential to such a degree that the axon membrane potential was above threshold after the refractory period had passed, the result being that at warmer temperatures a stimulus that normally evoked one action potential in the axon at lower temperatures now evoked a train of action potentials. The result at the axon terminal would be to release more neurotransmitter, possibly bringing the fiber potential close to or above the  $E_c$  threshold. Whether this is a mechanism actually used in live crabs to maintain normal muscle movement is uncertain. The Hawaiian ghost crab Q. ceratophthalma when warmed to 37°C experienced tremors and jerky movements (Florey and Hoyle, 1976) which may well be the result of additional generation of axon spikes as seen in P. crassipes.

#### Sensitivity of the neuromuscular system to the time course of acclimation

The ability of seasonal eurytherms and possibly even some warm water stenotherms to cope with cold temperatures may exist, but the time scale needed for them to acclimate may be much longer. The ability to adapt outside its normal temperature range was not found in Q. ceratophthalma (Florey and Hoyle, 1976). This crab lives in burrows and water within a very narrow temperature range of 26 to 28°C. The usual flight response of this crab was abolished at ambient temperatures less than 23°C. Movement of the ani-



mal was very sluggish below 20°C. Tension and EPSP amplitude in autotomized walking leg muscles declined outside the temperature range of 22 to 27°C. Unfortunately, no attempt was made to gradually acclimate O. ceratophthalma to a colder temperature. Temperate and tropical stone crabs that were acclimated over 7 weeks appeared almost immobile as did the ghost crabs when cooled. My data for M. mercenaria suggest that the time course of acclimation was too rapid to permit usual seasonal changes in the muscle fiber membrane to occur. Temperature associated changes in specific membrane resistance, input resistance, and space constants from rapid cold acclimation crabs were similar to data from warm acclimated crayfish (calculated from White, 1983). Changes in passive properties of 6 week cold acclimated crayfish were similar to responses in natural cold acclimated crabs. I have not tested whether it was the three week transition period from 30 to 8°C or the four weeks at 8°C that was too short a period of acclimation time.

Acclimation to winter temperatures may not be triggered by lower temperatures alone. Goldfish, when kept in the laboratory at a constant water temperature still showed seasonal changes in thermal tolerance (Hoar, 1956). Results of that study suggested photoperiod cues were also involved in acclimation.

Animals that are more likely to experience drastic daily or even weekly fluctuations in temperature may have enhanced ability to acclimate rapidly. Chapter 3 reports a study similar to this done on blue crabs Callinectes sapidus Rathbun from Chesapeake Bay, Maryland and southern Florida as that done on M. mercenaria. Blue crabs live in estuaries where temperatures may fluctuate more rapidly relative to coastal subtidal environments. Blue crabs from both populations seem capable of completely acclimating from 30 to 8°C within 4 weeks, as seen in both active and passive properties of their chela closer muscle fibers.

Likewise, crayfish are often found in fresh water ponds and streams where water temperature may fluctuate with rapidly changing air and land temperature. Such fluctuations may have enhanced the ability of crayfish to rapidly acclimate (from 24 to 12°C within two weeks, Harri and Florey, 1979). It would be interesting to compare membrane lipids and proteins within animals that are able to acclimate very rapidly with those that cannot. The ability to acclimate rapidly could reside in the capacity to incorporate unsaturated fatty acids into the lipid bilayer at low temperatures (perhaps a temperature related performance of a desaturase enzyme) or in the ability to rapidly change ionic protein structures.

#### Adaptations of populations to local environments

There are numerous examples of latitudinally separated species within a genus or even populations within a species that have become physiologically adapted to their temperature regime (see Vernberg, 1962 for review). Such adaptations occur in many systems within an organism: metabolism, growth, heat resistance or cold tolerance, reproductive effort, and rate of locomotion to name a few. Rearing separated populations in the same environment or transplanting them to habitats with a temperature regime unlike their own has shown that adaptations can be genetic (Alpatov, 1929; Moore, 1949; Dehnell, 1955; Levinton, 1983) or physiological (Kalabuchov, 1937; Rao, 1954; Pickens, 1965). Although I have found no evidence for adaptation to local environmental temperatures in the neuromuscular systems of either temperate or tropical population of M. mercenaria, there may well be population differences in other body systems such as those mentioned above. Lack of differentiation in neuromuscular performance between temperate and tropical M. mercenaria could be due to insufficient selection or evolutionary time to allow physiological divergence between the populations. Ocean currents may even

allow mixing of planktonic larvae between the two populations and thus provide a common gene pool.

Appendix. Raw data of passive properties measured in chela closer muscle fibers of M. mercenaria. Values are given for two bath temperatures (8 and 30°C)



Passive properties of muscle fibers at 8 and 30°C  
 North Carolina *M. mercenaria* (natural cold)

fiber diameter (μm)	space constant (cm)		R <sub>m</sub> (ohm cm <sup>2</sup> )		R <sub>i</sub> (ohm cm)		time constant (ms)		Capacit. (μF/cm <sup>2</sup> )		R <sub>input</sub>	
	8	30	8	30	8	30	8	30	8	30	8	30
500	0.410	0.341	1052	652	78	70	108.7	33.1	103.4	50.8	8173	6084
700	0.398	0.348	1088	414	120	60	97.9	34.2	90.0	82.8	6211	2698
600	0.535	0.391	2582	912	136	90	105.0	78.9	40.7	86.4	12808	6199
550	0.617	0.392	2466	720	88	64	113.0	58.1	45.8	80.8	11560	5307
500	0.340	0.437	3230	1482	350	98	75.8	42.5	23.5	28.7	30229	10799
350	0.588	0.680	3510	1612	88	30	165.0	86.5	47.0	53.7	27141	10771
750	0.498	0.241	3786	622	286	200	70.2	17.6	18.6	28.3	16145	5476
400	0.595	0.364	2854	598	80	46	119.5	36.5	41.9	61.1	19080	6544
mean	0.498	0.399	2571	877	153	82	106.9	48.4	51.3	59.1	16418	6735
SEM	0.0368	0.0449	363.3	154.7	37.1	18.5	10.33	8.49	10.61	8.18	3052.2	977.2

Passive properties of muscle fibers at 8 and 30°C  
 North Carolina *M. mercenaria* (rapid cold)

fiber diameter (μm)	space constant (cm)		Rm (ohm cm <sup>2</sup> )		Ri (ohm cm)		time constant (ms)		Capacit. (μF/cm <sup>2</sup> )		Rinput	
	8	30	8	30	8	30	8	30	8	30	8	30
400	0.645	0.321	1952	520	46	50	132.0	26.3	67.7	50.5	12035	6456
450	0.538	0.490	1524	1038	60	48	96.1	64.6	63.1	62.2	10021	7496
400	0.369	0.455	612	848	44	42	84.8	54.0	138.4	63.7	6605	7420
300	0.196	0.315	1056	692	206	52	31.0	33.0	29.4	47.6	28574	11640
300	0.127	0.189	714	612	334	86	14.8	16.3	20.7	26.6	29958	25742
300	0.225	0.245	400	286	60	36	47.3	12.1	118.3	42.4	9419	6171
300	0.317	0.211	778	450	58	76	56.9	18.8	73.1	41.8	13015	11328
mean	0.345	0.318	1005	635	115	56	66.1	32.2	72.9	47.8	15661	10893
SEM	0.0712	0.0441	208.5	95.2	42.4	6.9	15.35	7.55	16.26	4.84	3599	2613

Passive properties of muscle fibers at 8 and 30°C  
 Florida *M. mercenaria* (natural cold)

fiber diameter (μm)	space constant (cm)		R <sub>m</sub> (ohm cm <sup>2</sup> )		R <sub>i</sub> (ohm cm)		time constant (ms)		Capacit. (μF/cm <sup>2</sup> )		R <sub>input</sub>	
	8	30	8	30	8	30	8	30	8	30	8	30
750	0.397	0.255	1542	390	184	112	100.3	44.1	65.1	113.1	8246	3238
600	0.592	0.298	1714	334	74	56	110.1	22.2	64.3	66.3	7685	2984
400	0.658	0.176	3240	304	74	98	164.4	6.2	50.8	20.3	19594	6858
500	0.971	0.223	4628	436	62	110	307.4	21.5	66.4	49.5	15176	6218
mean	0.655	0.238	2781	366	99	94	170.6	23.5	61.6	62.3	12675	4825
SEM	0.1192	0.0258	724.3	29.4	28.6	13.0	47.74	7.80	3.65	19.42	2867.1	999.2

## REFERENCES

- Alpatov, W. W., 1929. Biometrical studies on variation and races of the honey bee (Apis mellifera L.). Quart. Rev. Biol. 4:1-58.
- Atwood, H. L., 1973. An attempt to account for the diversity of crustacean muscles. Amer. Zool. 13:357-378.
- Atwood, H. L., 1982. Synapses and Neurotransmitters. In Neurobiology: structure and function. Biology of Crustacea, Vol. 3, pp. 105-150. H. L. Atwood and D. C. Sandeman (eds.), Academic Press, New York, 479 pp.
- Baldwin, J. and Hochachka, P. W., 1970. Functional significance of isoenzymes in thermal acclimation: acetylcholinesterase from trout brain. Biochem. J. 116:883-887.
- Brown, S. C., S. R. Cassuto, and R. W. Loos, 1979. Biomechanics of chelipeds in some decapod crustaceans. J. Zool., Lond. 188:143-159.
- Chapple, W. D., 1982. Muscle. In Neurobiology: structure and function. Biology of Crustacea, Vol. 3, pp. 151-184. H. L. Atwood and D. C. Sandeman (eds.), Academic Press, New York, 479 pp.
- Charlton, M. P., and H. L. Atwood, 1979. Synaptic transmission: temperature-sensitivity of calcium entry in presynaptic terminals. Brain Res. 170:543-546.
- Dehnel, P. A., 1955. Rates of growth of gastropods as a function of latitude. Physiol. Zool. 28:115-144.
- Dudel, J. and R. Rudel, 1968. Temperature dependence of electro-mechanical coupling in crayfish muscle fibers. Pflug. Arch. 301:16-30.
- Elner, R. W. and A. Campbell, 1981. Force, function and mechanical advantage in the chelae of the American lobster Homarus americanus (Decapoda: Crustacea). J. Zool., Lond. 193:269-286.
- Fischbarg, J., 1972. Ionic permeability changes as the basis of the thermal dependence of the resting



potential in barnacle muscle fibres. J. Physiol. 224:149-171.

Fischer, L. and E. Florey, 1981. Temperature effects on neuromuscular transmission (opener muscle of crayfish, Astacus leptodactylus). J. Exp. Biol. 94:251-268.

Florey, E. and G. Hoyle, 1976. The effects of temperature on a nerve-muscle system of the Hawaiian ghost crab, Ocypode ceratophthalma (Pallas). J. Comp. Physiol. 110:51-64.

Harri, M. and E. Florey, 1977. The effects of temperature on a neuromuscular system of the crayfish, Astacus leptodactylus. J. Comp. Physiol. 117:47-61.

Harri, M. and E. Florey, 1979. The effects of acclimation temperature on a neuromuscular system of the crayfish, Astacus leptodactylus. J. Exp. Biol. 78:281-293.

Hazel, J. R., 1972. The effect of temperature acclimation upon succinic dehydrogenase activity from the epaxial muscle of the common goldfish (Carassius auratus L.). II. Lipid reactivation of the soluble enzyme. Comp. Biochem. Physiol. 43B:863-882.

Heinrich, B., 1974. Thermoregulation in endothermic insects. Science 185:747-756.

Hoar, W. S., 1956. Photoperiodism and thermal resistance of goldfish. Nature 178:364-365.

Hochachka, P. W. and G. N. Somero, 1984. Biochemical adaptation. Princeton University Press, Princeton, New Jersey, 538 pp.

Hodgkin, A. L. and W. A. H. Rushton, 1946. The electrical constants of a crustacean nerve fibre. Proc. Royal Soc. Lond. B133:444-479.

Jensen, D. W., 1972. The effect of temperature on transmission at the neuromuscular junction of the sartorius muscle of Rana pipiens. Comp. Biochem. Physiol. 41A:685-695.

Kalabuchov, N. J., 1937. Some physiological adaptations of the mountain and plains forms of the wood-mouse

(Apodemus sylvaticus) and of other species of mouse-like rodents. J. Anim. Ecol. 6:254-272.

Levinton, J. S., 1983. The latitudinal compensation hypothesis: growth data and a model of latitudinal growth differentiation based upon energy budgets. I. Interspecific comparison of Ophryotrocha (Polychaeta: Dorvilleidae). Biol. Bull. 165:686-698.

Martin, A. R., 1955. A further study of the statistical composition of the end-plate potential. J. Physiol. 130:114-122.

Moore, J. A., 1949. Geographic variation of temperature adaptation in Rana pipiens. Evol. 3:1-21.

Pearson, O. P., 1954. Habits of the lizard Liolaemus multiformis multiformis at high altitudes in Southern Peru. Copeia 1954:111-116.

Pickens, P. E., 1965. Heart rate of mussels as a function of latitude, intertidal height, and acclimation temperature. Physiol. Zool. 38:390-405.

Rao, K. P., 1954. Tidal rhythmicity of rate of water propulsion in Mytilus, and its modifiability by transplantation. Biol. Bull. 106:353-359.

Sokal, R. R. and F. J. Rohlf, 1969. Biometry. W. H. Freeman and Company, San Francisco, California, 776 pp.

Stephens, P. J., 1985. The effects of temperature and acclimation on crustacean nerve-muscle physiology. Biol. Bull. 169:92-105.

Stephens P. J. and H. L. Atwood, 1982. Thermal acclimation in a crustacean neuromuscular system. J. Exp. Biol. 98:39-47.

Stephens, P. J. and H. L. Atwood, 1983. Conversion of synaptic performance in crab motor axons by temperature changes. J. Comp. Physiol. 153:455-466.

Vernberg, F. J., 1962. Comparative physiology: latitudinal effects on physiological properties of animal populations. Ann. Rev. Physiol. 24:517-546.

White, R. L., 1983. Effects of acute temperature

change and acclimation temperature on neuromuscular function and lethality in crayfish. Physiol. Zool. 56:174-194.

Williams, A. B., 1984. Shrimps, lobsters, and crabs of the Atlantic coast of the eastern United States, Maine to Florida. Smithsonian Institution Press, Washington, D.C., 550 pp.

## CHAPTER 3

Effects of temperature and cold acclimation  
on neuromuscular properties of chelae  
in blue crabs Callinectes sapidus Rathbun



## INTRODUCTION

Animals that live in temperate eastern North America experience temperatures felt by both arctic and tropical animals. The degree to which their environmental temperature fluctuates depends however on the specific habitat. Terrestrial air breathers may experience changes in temperature of tens of degrees per hour. Temperate marine dwellers might be exposed to a fraction of this change over the period of a day.

Temperate ectotherms that are active year round must have behavioral or physiological mechanisms to maintain body performance. Those that live in habitats where large daily or weekly fluctuations in temperature are common must also be able to acclimate to these changes rapidly.

Chapter 2 presented evidence that suggested that temperate stone crabs Menippe mercenaria (Say) were capable of exerting similar levels of muscle stress with their chela year round at widely differing temperatures. A tropical population of M. mercenaria, although never having experienced the low temperatures felt by their temperate conspecifics, also showed eurythermic chela neuromuscular performance independent of season. Both temperate and tropical populations became weak and sluggish when rapidly acclimated to cold in the laboratory. M. mercenaria does not experience such drastic temperature changes ( $-22^{\circ}\text{C}$  in 3 weeks) in its marine subtidal habitat. Crayfish (Astacus leptodactylus) are quite unlike stone crabs in habitat and acclimation ability. They live in fresh water streams, lakes, and ponds, where because of the influence of air and land, large temperature fluctuations are common. A. leptodactylus exhibited normal body movement from  $0$  to  $30^{\circ}\text{C}$ , and acclimated from  $24$  to  $12^{\circ}\text{C}$  in 2 weeks (Harri and Florey, 1979).

In this chapter, I investigated the ability of latitudinally separated populations of blue crabs Callinectes

sapidus Rathbun to function at temperature extremes only experienced by the more northerly population. Crabs in the Chesapeake Bay experience temperatures ranging from 4 to 30 °C, while those in southwestern Florida are exposed to a range of temperatures from 15 to 30°C. As in Chapter 2, I hypothesized that differences in thermal regimes between the two latitudes result in physiologically distinct populations. To test this, I measured temperature associated changes in the chela neuromuscular system of northern and southern blue crabs. Both populations live in estuaries where temperatures fluctuate more on a daily or weekly basis relative to the marine environment. I therefore compared temperature acclimation ability in northern and southern populations.

Northern and southern blue crabs showed similar neuromuscular responses to changes in temperature. Both populations were capable of exerting equal chela muscle stress at summer and temperate winter temperatures. Acclimation (as measured by muscle performance) to low temperature (from 30 to 8°C) was complete by 4 weeks.

Blue crabs are relatively fast moving and swimming decapods, and have even been known to capture fish (Williams, 1984). Usual feeding behavior will be preserved at cooler temperatures only if muscle force and speed of contraction are maintained in the cold. To examine this possibility, effects of temperature on contraction speed were studied in warm and cold acclimated blue crabs.

Changes in temperature had no effect on speed of dactyl movement in autotomized chelae from warm acclimated crabs. Dactyl speed at 8°C was similar between warm and cold acclimated crab chelae. This was contradicted by behavior of live cold acclimated blue crabs in the field and in the laboratory, where crabs was very sluggish. It is likely that the most temperature sensitive component of the neuromuscular system is within the central nervous system.



## METHODS

### Maintenance of animals

Callinectes sapidus caught in Chesapeake Bay, Maryland were purchased from a local seafood retailer. Blue crabs from Florida were caught in the Caloosahatchee River near Cape Coral. These Florida crabs are flown year round to a retailer in Maryland.

Each crab was maintained in artificial sea water (20 ppt salinity) in a small 10 gallon aquarium. Details of the salt water system are described in Chapter 2 methods. Crabs were fed chunks of frozen fish twice weekly.

Experiments described in this chapter took place during the summers of 1984 and 1985.

### Temperature treatments

Blue crabs were held at 25°C in laboratory aquaria after they were acquired. To accomplish rapid cold acclimation, crabs were placed from 25°C directly into 8°C water and held at this temperature for 4 weeks before experimentation.

### Chela closer muscle performance in intact crabs

Muscle stress is defined as the force exerted by the muscle fiber per unit of fiber cross-sectional area. Muscle stress measurements were taken from Maryland and Florida blue crabs after 4 weeks of either warm or cold acclimation. Chela force was measured using a force transducer described in Chapter 1. Muscle stress was calculated using chela morphology measurements and formulae also described in Chapter 1.

Muscle stress was measured from chelae of a narrow size range. Therefore, instead of regressing muscle stress onto chela size, values of stress were averaged within different temperature treatments and populations. A one-way analysis of variance (ANOVA) was used to compare changes in

mean muscle stress among treatments. If the ANOVA was significant, differences in means were tested with a Student-Neuman-Keuls multiple test procedure. Homogeneity of variance was assured with Bartlett's test for homogeneity of variance (Sokal and Rohlf, 1969).

#### Measurements from autotomized crab chela

Active neuromuscular properties. The dissection to expose the chela closer muscle and motor axons was very similar to that used for M. mercenaria, details of which are described in Chapter 2. The recording chamber, physiological saline, temperature control, and techniques of intracellular recording are identical to those used for M. mercenaria and are also described in Chapter 2.

Speed of dactyl movement was measured by connecting the dactyl tip to a Grass FT03C force transducer with a light spring (0.3 gm/cm). Input from the force transducer was amplified and recorded on a Brush 220 chart recorder. In this manner, speed of isotonic contraction was measured with very little load on the dactyl. Chela gape (in degrees) was measured before contraction so that dactyl movement could be expressed in degree of rotation per millisecond. Axonal stimulation was delivered with platinum hook electrodes connected to a Grass SD9 square wave generator (1 ms pulses at 80 Hz). Voltage was sufficient to excite both fast and slow excitatory motor axons (as seen by measuring axon action potentials with a suction electrode connected to an oscilloscope). Two trials were taken from the chela at each of three experimental temperatures (8, 20 and 30°C).

Passive membrane properties. Muscle fiber cable properties were determined by measuring the response of fibers to 1000 nA of hyperpolarizing current at various measured distances away from the location of current injection. Details of measuring fiber input resistance, space constant and time constant are found in Chapter 2.



The formulae for calculating specific fiber resistance and capacitance are also given there.

Temperature associated changes in fiber passive properties were presented in terms of a change per  $-10^{\circ}\text{C}$  by:

$$\left(\frac{\text{value at } 8^{\circ}\text{C}}{\text{value at } 30^{\circ}\text{C}}\right)^{1.0/22}$$

## RESULTS

Chela closer muscle performance in intact crabs

Warm and rapid cold acclimated blue crabs from Florida and Maryland exerted equal levels of muscle stress and dactyl force (Table VII). Maximum values for crusher dactyl force and muscle stress were 37 N and 134 N/cm<sup>2</sup>, respectively. These forces were for crabs having a carapace width range of 125 to 150 mm and a chela length range of 66 to 82 mm. Average angles of pinnation used to calculate muscle stress were 33° for cutter chelae and 31° for the crusher chelae (Blundon and Kennedy, 1982).

Measurements from autotomized crab chelae

Active neuromuscular properties. Both Maryland and Florida warm and rapid cold acclimated crabs showed similar changes in both active and passive fiber properties with temperature. Data from the two populations were therefore pooled to compare warm and rapid cold acclimation treatments. Warm and rapid cold acclimated muscle fibers showed equal levels of muscle fiber resting membrane potential (RMP) at 8 and 30°C (Table VIII). In neither treatment could the degree of change in the RMP with temperature be accounted for solely by the Nernst equation prediction ( $-0.2 \text{ mV degree}^{-1}$ ). Excitatory post-synaptic potential (EPSP) amplitude was similar for both acclimation treatments when comparing means at 8°C or at 30°C. However, warm acclimated muscle fibers experienced a significant increase in EPSP amplitude at 30°C (Table VIII). At 8°C, trains of EPSPs evoked by stimulus frequencies of 10 Hz or greater were notably different between warm and rapid cold acclimated crab muscle fibers (Figure 11). EPSPs of rapid cold acclimated fibers summated to depolarize the fiber well over the amplitude of a single EPSP. This was not seen in warm acclimated muscle fibers. EPSP trains at 30°C were similar for both warm and rapid cold acclimated

Table VII. Muscle stresses and dactyl tip forces of chelae of warm and rapid cold acclimated C. sapidus. SEM = standard error of means, n = sample size

COMPARISONS OF CHELA PERFORMANCE  
in Callinectes sapidus  
Mean  $\pm$  SEM (n)

	<u>Warm</u>	<u>Rapid cold</u>
<u>Crusher muscle fiber stress (N/cm<sup>2</sup>)</u>		
Chesapeake Bay	<sup>a</sup> 93.0 $\pm$ 22.60 ( 7)	<sup>a</sup> 83.0 $\pm$ 7.28 ( 8)
Florida	<sup>a</sup> 108.8 $\pm$ 5.27 (15)	<sup>a</sup> 81.3 $\pm$ 10.20 ( 4)
<u>Crusher dactyl tip force (N)</u>		
Chesapeake Bay	<sup>b</sup> 31.7 $\pm$ 6.10 ( 7)	<sup>b</sup> 23.4 $\pm$ 1.87 ( 8)
Florida	<sup>b</sup> 27.9 $\pm$ 1.47 (15)	<sup>b</sup> 22.0 $\pm$ 2.80 ( 4)

a, b

similar superscripts denote no significant difference between means (P > 0.05)



Table VIII. Means of neuromuscular properties of chela muscle fibers in warm and rapid cold acclimated C. sapidus at 8 and 30°C bath temperatures. SEM = standard error of means, n = sample size, RMP = resting membrane potential, EPSP = excitatory post-synaptic potential

COMPARISONS OF NEUROMUSCULAR PROPERTIES  
Mean  $\pm$  SEM (n)

	<u>8°C</u>	<u>30°C</u>
<u>RMP (mV)</u>		
Warm	a -62.0 $\pm$ 2.65 (7)	b -76.6 $\pm$ 3.27 (7)
Rapid cold	a -69.4 $\pm$ 3.35 (8)	b -79.1 $\pm$ 1.82 (8)
<u>EPSP amplitude (mV)</u>		
Warm	c 0.5 $\pm$ 0.09 (7)	d 2.0 $\pm$ 0.54 (7)
Rapid cold	ce 0.8 $\pm$ 0.20 (9)	de 1.5 $\pm$ 0.37 (9)

a-e

superscripts with at least one letter in common denote no significant difference between means (P > 0.05)

Figure 11. EPSPs evoked by stimulation at 5, 10, and 20 Hz (for each bath temperature of 8 and 30°C) from chela muscle fibers of rapid cold acclimated (A) and warm acclimated (B) C. sapidus. Horizontal scale = 500 ms, vertical scale = 5 mV in A and lower B, 1 mV in upper B

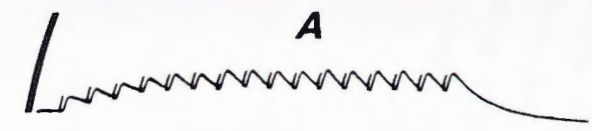

8°C

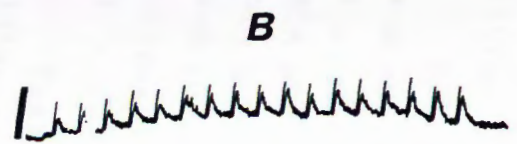

30°C

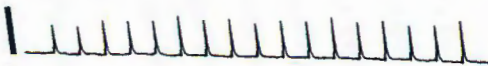



muscle fibers (Figure 11). It was difficult to measure level of fiber depolarization with EPSP trains evoked by stimulus frequencies above 20 Hz. At higher frequencies the intracellular record was often obscured by movement artifacts (especially at 8°C).

Speed of dactyl movement in both Maryland and Florida warm acclimated crabs was independent of temperature (Table IX). Rapid cold acclimated chelae contracted as fast as warm acclimated chelae at 8°C, but upon warming the rapid cold acclimated chelae, speed of dactyl movement slowed down remarkably. Motor axon bundles of warm and rapid cold acclimation chelae were capable of being stimulated at 80 Hz.

Passive membrane properties. Specific membrane resistance is similar for both Florida and Maryland warm and rapid cold acclimated C. sapidus at 30°C. At 8°C, both Maryland and Florida rapid cold acclimated treatments show significantly higher membrane resistance relative to warm acclimated preparations (Figure 12). However, when comparing change per -10°C in space constant, input resistance, specific resistance, time constant, or capacitance among both acclimation treatments and populations, differences in means are not significant (Table X).

Table IX. Speed of dactyl movement in C. *sapidus* from various temperature treatments at 8, 20 and 30°C. Standard error of means in parentheses, n = 2

SPEED OF DACTYL MOVEMENT  
 (degrees per ms)  
 Mean  $\pm$  SEM n = 2

prep temp.	<u>8°C</u>	<u>20°C</u>	<u>30°C</u>
Chesapeake Bay warm	0.106 $\pm$ 0.0032	0.073 $\pm$ 0.0061	0.095 $\pm$ 0.0026
Florida warm	0.050 $\pm$ 0.0039	0.071 $\pm$ 0.0067	0.074 $\pm$ 0.0015
Chesapeake Bay rapid cold	0.044 $\pm$ 0.0026	0.021 $\pm$ 0.0042	0.002 $\pm$ 0.0002
Florida rapid cold	0.065 $\pm$ 0.0026	0.033 $\pm$ 0.0026	0.005 $\pm$ 0.0017

Figure 12. Means (+ 1 standard error) of specific membrane resistance of chela muscle fibers from Maryland and Florida warm and rapid cold acclimated C. sapidus as a function of bath temperature. x denotes significant difference from values without x



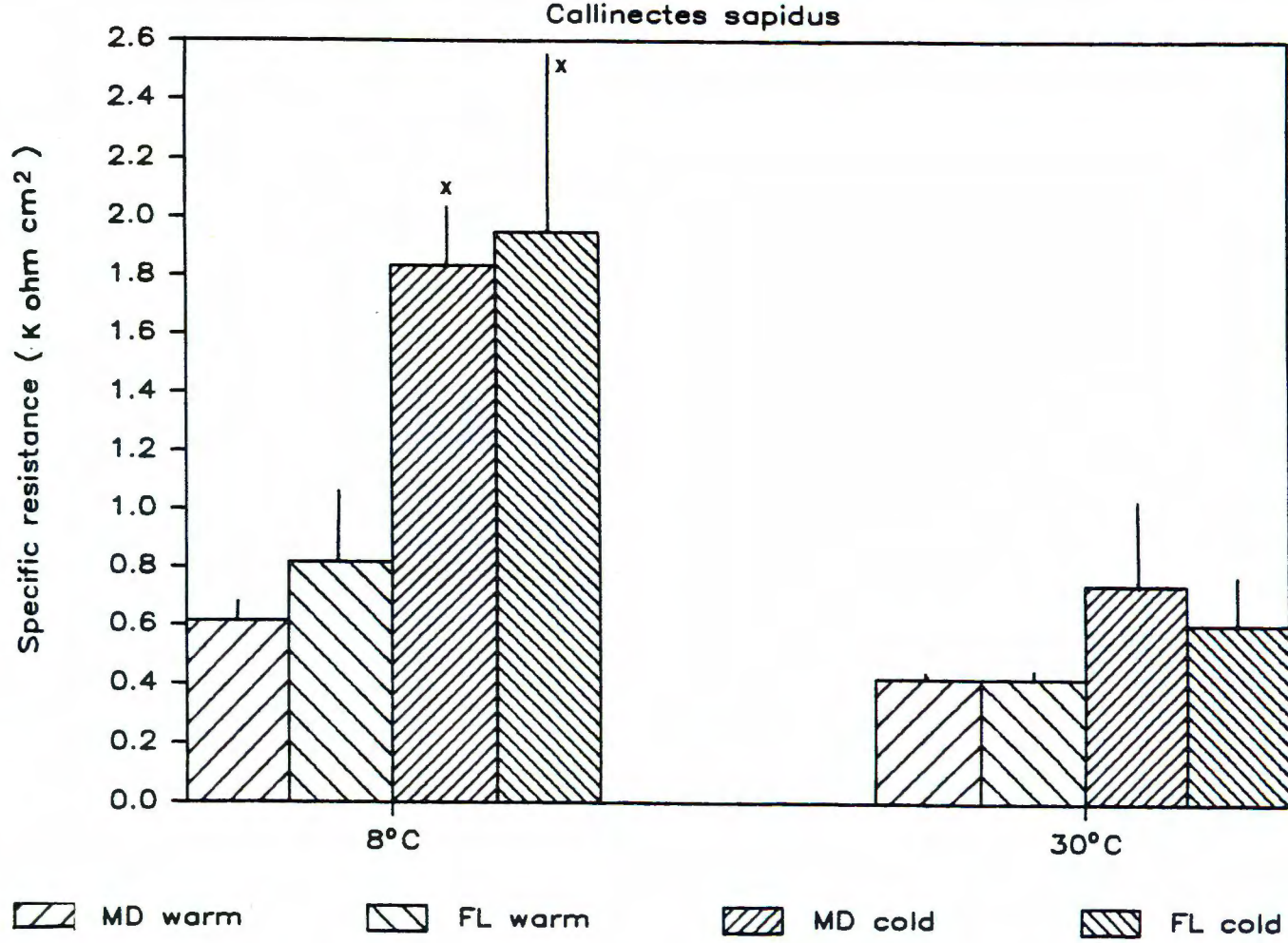

Table X. Temperature associated changes in passive properties of chela muscle fibers of Maryland and Florida warm and rapid cold acclimated C. *sapidus*. Values are the amount of change in a given property for  $-10^{\circ}\text{C}$ , measured from  $30$  to  $8^{\circ}\text{C}$ . SEM = standard error of means, n = sample size

AMOUNT OF CHANGE FOR 10°C COOLING  
Mean  $\pm$  SEM (n)

	Florida <u>warm</u>	Chesapeake Bay <u>warm</u>	Florida <u>rapid cold</u>	Chesapeake Bay <u>rapid cold</u>
space constant	a 1.18 $\pm$ 0.101 (4)	a 1.02 $\pm$ 0.083 (2)	a 1.31 $\pm$ 0.232 (3)	a 1.05 $\pm$ 0.131 (4)
specific resistance	b 1.28 $\pm$ 0.213 (4)	b 1.18 $\pm$ 0.073 (2)	b 1.75 $\pm$ 0.365 (3)	b 1.68 $\pm$ 0.205 (4)
input resistance	c 1.08 $\pm$ 0.123 (4)	c 1.17 $\pm$ 0.167 (2)	c 1.37 $\pm$ 0.222 (3)	c 1.61 $\pm$ 0.099 (4)
time constant	d 1.31 $\pm$ 0.326 (4)	d 1.55 $\pm$ 0.111 (2)	d 2.22 $\pm$ 0.892 (3)	d 1.80 $\pm$ 0.698 (4)
capacitance	e 0.97 $\pm$ 0.114 (4)	e 1.32 $\pm$ 0.176 (2)	e 1.20 $\pm$ 0.288 (3)	e 1.01 $\pm$ 0.294 (4)

a-e

similar superscripts denote no significant difference between means ( $P > 0.05$ )

## DISCUSSION

Although both Menippe mercenaria and Callinectes sapidus can maintain chela performance irrespective of season, it is clear that the ability of both Maryland and Florida C. sapidus to cope with sizable changes in temperature is superior. This ability is undoubtedly essential in maintaining normal body function in the more thermally variable environment where C. sapidus is found. Muscle performance in crayfish Astacus leptodactylus showed rapid acclimation to large temperature decreases ( $-12^{\circ}\text{C}$  in 2 weeks, Harri and Florey, 1979). Crayfish live in fresh water inland habitat where large short term fluctuations in temperature are also common.

Temperature and muscle stress

Maintenance of stress in rapid acclimated blue crab muscle fibers resulted from increased specific membrane resistance of the muscle fiber membrane at low temperatures. Increased membrane resistance led to increased EPSP duration and summation in this study (M. mercenaria and C. sapidus) and in others (Harri and Florey, 1979; Fischer and Florey, 1981). In this aspect, blue crab rapid cold acclimated muscle fibers are similar to natural cold acclimated stone crab fibers, and blue crab warm acclimated fibers are similar to stone crab rapid cold acclimated (i.e. unacclimated) muscle fibers. Specific passive property components such as input resistance and space constant do not appear to be as temperature dependent in blue crab muscle fibers as they are in stone crab muscle fibers when comparing changes per  $-10^{\circ}\text{C}$  (Table X).

Although the chelae of C. sapidus are dimorphic (crusher and cutter), the blue crab is not a specialized crushing predator. Blue crab crushers are smaller and more slender than M. mercenaria crushers. They also possess



smaller muscles and inferior chela mechanical advantages (see Chapter 1 and Govind and Blundon, 1985). Forces generated at the dactyl tip are 5 to 10 times less in blue crab crushers than stone crab crushers. The diet of blue crabs is much more general than that of stone crabs (Virnstein, 1977) and therefore speed of chela movement may sometimes be as important as chela force in obtaining a meal.

#### Temperature and speed of movement

Preservation of muscle stress is only one requirement in maintaining constancy of normal body function. If speed of muscle contraction is affected by temperature, then muscle power (force per unit time) will be temperature dependent. This may be of little consequence in a normally sluggish animal such as the stone crab, but in a rapidly moving blue crab, maintenance of power is crucial. Results of speed of dactyl movement from autotomized blue crab chelae indicated that contraction speed is unaffected by low temperatures. However, this is clearly not the case for the whole crab. Even though they are able to squeeze the force transducer with stresses comparable to summer crabs, live crabs acclimated to low temperatures are much more sluggish. I have observed this in rapid cold acclimated crabs in the laboratory and in blue crabs seen in the field while SCUBA diving during the winter (the only time I was ever able to hand collect a blue crab in the field).

The neuromuscular synapse and muscle fiber are only two components of the nervous and muscular system that function during locomotion. Motor, sensory, and interneurons in the central and peripheral nervous systems all participate in the normal performance of movement. The limiting factor of whole animal movement at low temperatures may be within these structures and not at the neuromuscular synapse or muscle fiber. Cockroaches (Periplaneta americana) lost locomotor ability below 10°C, although

motor neuron action potentials and excitatory muscle potentials were recorded several degrees below this temperature (Bradfish et alia, 1982). The monosynaptic connection between the trochanteral hair plate sensory afferent neuron and the motor neuron innervating the coxal depressor muscle showed decoupling (an increase in failures) as the cockroach was cooled. Bradfish et alia (1982) suggested that integrative processes within the central nervous system may be the most temperature sensitive.

The inability of blue crabs to move about at low temperatures may be one reason for the animal's winter hibernation. In the Chesapeake Bay, female blue crabs migrate to the mouth of the bay and burrow into the sediment during the winter months. Male blue crabs burrow in the deeper channels of the bay and rivers. Temperatures in the Caloosahatchee River, Florida do not approach those that induce burrowing in Chesapeake Bay blue crabs. An interesting observation that accompanies this fact is that Chesapeake Bay blue crabs, when cooled below 10°C, performed a digging motion with their walking legs as if trying to burrow (although there was no sediment in the aquaria). This stereotyped movement was never seen in Florida blue crabs at the same or lower temperatures. It would be interesting to determine if this complex behavior pattern were linked to temperature dependent changes in the nervous system of northern blue crabs that are absent in Florida blue crabs.

In conclusion, the ability of C. sapidus to generate equal amount of muscle stress at 8 and 30°C irrespective of the temperature regime of its local environment no doubt plays an important role in the successful dispersal of the species across latitudinal gradients. Its capacity to rapidly acclimate to large decreases in temperature is an important feature of its physiology that allows habitation of environments where large short term fluctuations in temperature are common.

Appendix. Raw data of passive properties measured in chela muscle fibers of C. *sapidus*. Values are given for two bath temperatures (8 and 30°C)



Passive properties of muscle fibers at 8 and 30°C

Florida *C. sapidus* (warm acclimated)

fiber diameter (μm)	space constant (cm)		Rm (ohm cm <sup>2</sup> )		Ri (ohm cm)		time constant (ms)		Capacit. (uF/cm <sup>2</sup> )		Rinput	
	8	30	8	30	8	30	8	30	8	30	8	30
600	0.237	0.312	262	462	70	72	11.7	46.7	44.6	101.3	2940	3926
200	0.717	0.382	1260	398	12	14	177.5	52.8	140.8	132.7	13997	8306
400	0.325	0.217	1322	484	126	102	57.9	13.3	43.8	27.4	16209	8842
250	0.342	0.199	422	342	22	54	39.9	37.7	94.8	110.3	7832	10937
mean	0.405	0.278	817	422	58	61	71.8	37.6	81.0	92.9	10245	8003
SEM	0.1064	0.0428	276.2	32.2	26.1	18.4	36.51	8.68	23.22	22.81	3011.5	1472.7

Florida *C. sapidus* (rapid cold acclimated)

fiber diameter (μm)	space constant (cm)		Rm (ohm cm <sup>2</sup> )		Ri (ohm cm)		time constant (ms)		Capacit. (uF/cm <sup>2</sup> )		Rinput	
	8	30	8	30	8	30	8	30	8	30	8	30
450	0.613	0.196	3112	424	94	124	178.0	8.7	57.2	20.5	17940	7670
550	0.202	0.265	1082	450	364	88	35.7	39.6	33.1	88.0	15502	4914
900	0.297	0.147	1654	940	422	982	45.5	12.9	27.5	13.8	9860	11325
mean	0.371	0.203	1949	605	293	398	86.4	20.4	39.3	40.7	14434	7970
SEM	0.1242	0.0342	604.3	167.8	101.1	292.2	45.89	9.68	9.12	23.69	2392.8	1856.8



Passive properties of muscle fibers at 8 and 30°C

Chesapeake Bay *C. sapidus* (warm acclimated)

fiber diameter (μm)	space constant (cm)		Rm (ohm cm <sup>2</sup> )		Ri (ohm cm)		time constant (ms)		Capacit. (uF/cm <sup>2</sup> )		Rinput	
	8	30	8	30	8	30	8	30	8	30	8	30
300	0.205	0.236	692	418	124	56	73.8	33.0	106.5	78.8	17904	9412
300	0.183	0.147	534	424	120	146	35.6	11.6	66.6	27.4	15473	15284
mean	0.194	0.192	613	421	122	101	54.7	22.3	86.5	53.1	16689	12348
SEM	0.0110	0.0445	79.0	3.0	2.0	45.0	19.10	10.70	19.92	25.75	1215.5	2936.0

Chesapeake Bay *C. sapidus* (rapid cold acclimated)

fiber diameter (μm)	space constant (cm)		Rm (ohm cm <sup>2</sup> )		Ri (ohm cm)		time constant (ms)		Capacit. (uF/cm <sup>2</sup> )		Rinput	
	8	30	8	30	8	30	8	30	8	30	8	30
400	0.185	0.201	1604	428	470	106	32.2	22.2	20.1	51.9	34573	8469
700	0.373	0.188	2290	474	288	236	95.5	4.9	41.7	10.4	13950	5736
400	0.151	0.287	1994	1642	874	200	22.2	39.1	11.2	23.8	52506	22807
400	0.297	0.229	1446	416	164	78	53.5	26.4	37.0	63.6	19377	7200
mean	0.252	0.226	1834	740	449	155	50.9	23.2	27.5	37.4	30102	11053
SEM	0.0511	0.0220	190.8	300.9	155.0	37.5	16.25	7.06	7.16	12.29	8649.9	3957.6

## REFERENCES

- Blundon, J. A. And V. S. Kennedy, 1982. Mechanical and behavioral aspects of blue crab, Callinectes sapidus Rathbun, predation on Chesapeake Bay bivalves. J. Exp. Mar. Biol. Ecol. 65:47-65.
- Bradfish, G. A., C. D. Drewer, and J. A. Mutchmor, 1982. The effects of cooling on an identified reflex pathway in the cockroach (Periplaneta americana), in relation to chill-coma. J. Exp. Biol. 96:131-141.
- Fischer, L. and E. Florey, 1981. Temperature effects on neuromuscular transmission (opener muscle of crayfish, Astacus leptodactylus). J. Exp. Biol. 94:251-268.
- Govind, C. K. and J. A. Blundon, 1985. Form and function of the asymmetric chelae in blue crabs with normal and reversed handedness. Biol. Bull. 168:321-331.
- Harri, M. and E. Florey, 1979. The effects of acclimation temperature on a neuromuscular system of the crayfish, Astacus leptodactylus. J. Exp. Biol. 78:281-293.
- Sokal, R. R. and F. J. Rohlf, 1969. Biometry. W. H. Freeman and Company, San Francisco, California, 776 pp.
- Virnstein, R. W., 1977. The importance of predation by crabs and fishes on benthic infauna in Chesapeake Bay. Ecology 58:1199-1217.
- Williams, A. B., 1984. Shrimps, lobsters, and crabs of the Atlantic coast of the eastern United States, Maine to Florida. Smithsonian Institution Press, Washington, D.C., 550 pp.