

Manuscript ID: 784

DOI: 10.18462/iir.icr.2019.784

Subcooling with AC and adiabatic gas cooling for energy efficiency improvement: field tests and modelling of CO₂ booster systems

Giovanni CORTELLA, Michele A. COPPOLA, Paola D'AGARO

DPIA – University of Udine
Udine, 33100, Italy
giovanni.cortella@uniud.it

ABSTRACT

In the last decade several plant configurations and components have been proposed to increase the efficiency of CO₂ refrigeration systems. Among these, subcooling is considered a simple but effective solution, together with the employment of adiabatic cooling systems at the gas cooler.

In this work, a fully instrumented CO₂ booster plant installed in a supermarket is considered, to compare parallel compression, subcooling and adiabatic cooling. Subcooling is performed taking advantage of chilled water available from the HVAC system. The experimental data are used to validate a model for the comparison on a yearly basis.

Parallel compression and subcooling show to be almost equivalent in terms of yearly energy use, while the adiabatic cooling system gives the best performance.

Comparisons reveal that the subcooler cooling capacity should be chosen carefully to avoid oversizing, while the influence of the EER for the chiller appears quite small. Subcooling performed at the expense of an HVAC plant shows to be an interesting solution, while a great benefit was experienced with the employment of an adiabatic gas cooler.

Keywords: Carbon Dioxide, Commercial refrigeration, Energy saving, Modelling, Monitoring, Subcooling, Supermarket

1. INTRODUCTION

In order to extend the convenience of use of CO₂ in warm climates, several technologies and alternative plant schemes have been studied and analyzed, showing that improvements of the performance of trans-critical CO₂ refrigeration plants can be achieved. Among the available solutions, the improvements associated with subcooling are being recently investigated by many researchers (Llopis et al., 2018). If we focus on booster systems in transcritical conditions, it permits to reduce the amount of flash gas at the liquid receiver, and allows to decrease the optimal rejection pressure providing additional advantage (Llopis et al., 2015). The subcooling function can also be performed by means of a secondary fluid for other purposes, like air conditioning chillers, or taking advantage of water storage systems (Polzot et al., 2015, Polzot et al., 2016). Several investigations are available in the literature about the performance of CO₂ systems with subcooling at laboratory conditions (e.g. Bush et al., 2017, Nebot-Andrés et al., 2018), but very few information is available on the behavior of an actual plant. In this paper, a fully instrumented CO₂ booster plant installed in an actual supermarket is monitored (Cortella et al., 2018), to compare its performance with parallel compression, subcooling and adiabatic cooling. Subcooling is performed taking advantage of chilled water from the HVAC system. The experimental data are used to validate a comprehensive model, which includes display cabinets and the building, for the comparison of the various solutions on a yearly basis.

2. THE REFRIGERATION SYSTEM AND ITS MODEL

The Commercial Refrigerating Unit (CRU) analyzed in this work is a transcritical CO₂ booster system with parallel compression and subcooling provided by chilled water from a HVAC plant. Such plant is part of a test system installed in a small supermarket (1200 m² selling area) which has been refurbished in the framework of the FP7 European Project *CommONEnergy* (Commonenergy 2017). The nominal cooling capacity is 70.5 kW at -35 °C and 10.8 kW at -10 °C respectively for the MT and LT applications. The intermediate pressure at the liquid receiver is 35 bar. Both compressor racks, LS and HS, are composed of two compressors, distinguished as master and slave compressor. The master is controlled by an inverter and the slave is an ON/OFF type.

The gas cooler is equipped with an Adiabatic Cooling System (ACS) made of evaporative pads positioned on the long sides of the gas cooler, so that only a fraction of the air flow rate undergoes adiabatic saturation. Pads are fed with water when the outdoor temperature exceeds a set point value. A mixing ratio ε of the overall process, that takes into account both the position and the efficiency of the panels themselves, is defined based on the wet and dry bulb (T_{wb} and T_{db}) outdoor air temperature, so that the temperature of air at the inlet of the heat exchanger is

$$T_{in,air,GC} = T_{wb}\varepsilon + T_{db}(1 - \varepsilon) \quad \text{Eq. (1)}$$

The mixing ratio is estimated at $\varepsilon = 0.6$, value that has been proven empirically to be adequate and well chosen. In this way, the temperature at the outlet of the gas cooler is then evaluated as:

$$T_{out,GC} = T_{in,air,GC} + \Delta T_{app,GC} \quad \text{Eq. (2)}$$

The adiabatic saturation of air is described in the model using the CoolProp libraries (Bell et al., 2014) for humid air. The control rule for setting the optimal HS pressure is based on the CO₂ temperature at the gas cooler outlet, based on a correlation optimized for this specific design without (Eq. 3) and with (Eq. 4) parallel compressor with constant intermediate pressure (Polzot et al., 2016, D'Agaro et al., 2019):

$$p_{GC,out} = \max(75; 2.56 T_{GC,out} - 1.247) \quad \text{Eq. (3)}$$

$$p_{GC,out} = \max(75; 1.75 T_{GC,out} + 22.13) \quad \text{Eq. (4)}$$

Due to this control rule, the adoption of the ACS allows a reduction of the pressure ratio at the HS compressors, with benefits in terms of energy consumption.

As an alternative to ACS, a heat exchanger can be activated in order to perform subcooling at the exit of the gas cooler/condenser. The beneficial effects of subcooling in a transcritical booster system are well known (Llopis et al., 2018), and make the use of CO₂ plants attractive also at warm climate conditions. In this system, subcooling is made at the expense of chilled water from the HVAC system. This solution has been chosen thanks to its low investment cost, given that the water chiller was already available and adequately sized, and to the simplicity of regulation when compared to a traditional dedicated mechanical subcooler. Chilled water is supplied at 7 to 9 °C to the heat exchanger which is designed for a maximum heat exchange of 18 kW. The investigated plant enables several configurations, and is also designed to allow waste heat recovery at two temperature levels for space heating and hot water production, and cooling capacity for air conditioning. Such features are not considered in this paper, but a detailed analysis is described in D'Agaro et al. (2018), D'Agaro et al. (2019).

Fig. 1 shows a schematic drawing of the refrigerating system, where also the additional heat exchangers for heat and cooling recovery are depicted, as well as the main measurement points.

Mathematical models of the refrigeration system, display cabinets and cold rooms have been developed in the TRNSYS environment, including mutual interactions with the building and its HVAC system, at given climate conditions. A sub-hourly cooling load profile is thus predicted based on the realistic and time-dependent working conditions in the supermarket, as well as on the interactions between the cabinets and the indoor climate (Polzot et al., 2016). The thermodynamic and thermophysical properties of the refrigerants are calculated by linking our in-house routines in the TRNSYS environment to the CoolProp libraries (Bell et al., 2014). The compressors are described through correlations provided by the manufacturer in accordance with the Standard EN12900:2013.

The values of the main design parameters are reported in Table 1.

Table 1. Main design parameters for the commercial refrigeration unit

Parameter	Unit	Value
LT evaporating temperature	°C	-35
MT evaporating temperature	°C	-10
Minimum condensing temperature	°C	6
Liquid receiver pressure	bar	35
Degree of subcooling at subcritical conditions	K	3
Gas Cooler/Condenser ΔT_{app}	K	4
Subcooler heat exchanger ΔT_{app}	K	7
Superheat at LS/HS suction	K	30/20

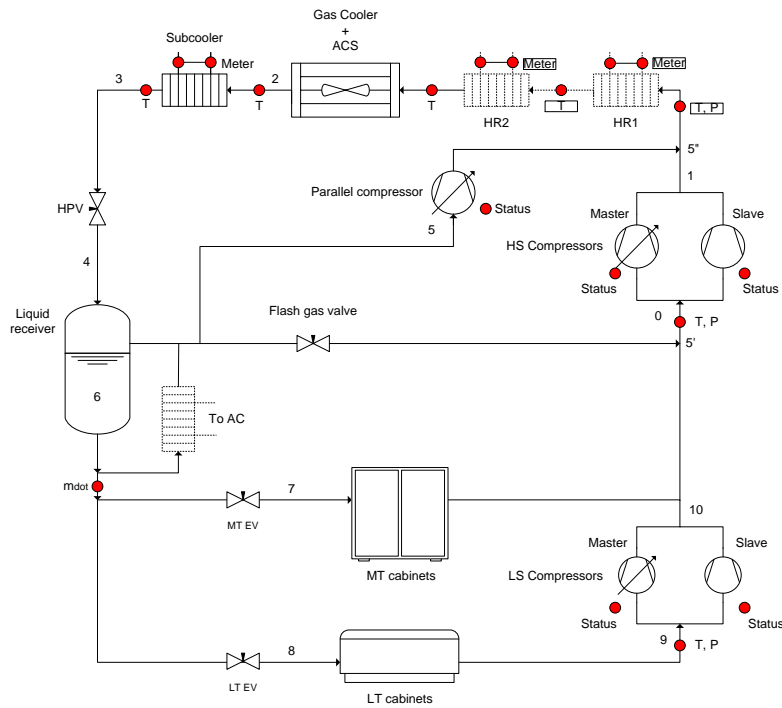

Figure 1: Schematic drawing of the CO₂ refrigeration system. The approximate position of the probes is indicated by the red flags. T: temperature probe, P: pressure gauge, Meter: energy meter, mdot: mass flow meter, Status: compressor status sensor

3. FIELD TESTS AND MODEL VALIDATION

With the aim of validating the model at warm climate conditions and checking the efficacy of subcooling compared to the use of ACS, the system has been operated during summer 2018. The outcomes of the data acquisition have been used for comparison with the model prediction, thus allowing the identification of the pros and cons of each solution. Five weeks have been selected as representative of three different operating conditions:

Adiabatic Cooling System	(ACS)	week 1 (1-7 June, 2018) and 2 (15-21 June, 2018);
Subcooling	(SC)	week 3 (7- 13 Sept, 2018) and 4 (14-20 Sept, 2018);
Both systems	(ACS + SC)	week 5 (27 July to 2 August, 2018).

3.1. Adiabatic Cooling System (ACS)

The employment of the ACS system showed to be quite effective in reducing the gas cooler outlet temperature, and consequently the gas cooler pressure. Fig. 2 shows an example of the difference between the gas-cooler pressure predicted in dry gas-cooling conditions and the one measured with ACS, for weeks 1 and 2.

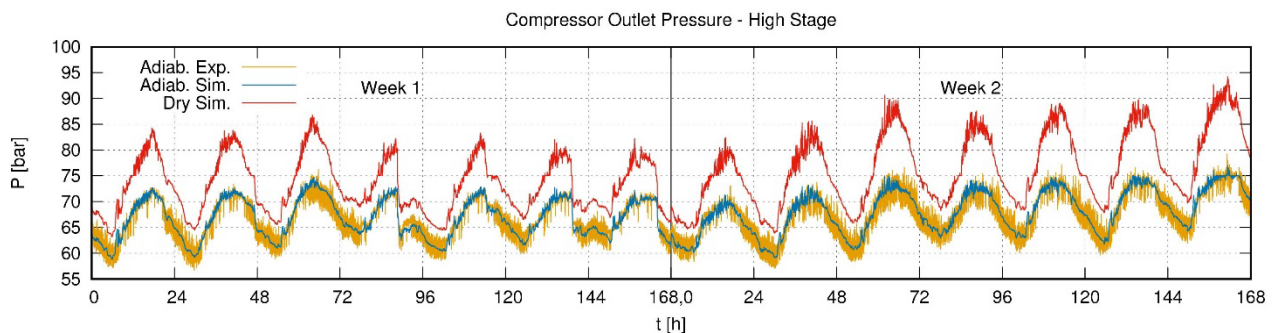

Figure 2: HS pressure: comparison between dry and adiabatic cooling, and between experimental and simulated results in weeks 1 and 2

An average reduction of 4K in the gas cooler outlet temperature can be achieved by using ACS, corresponding to a reduction of approximately 10 bar in the HS pressure. Also the computed values of the HS pressure with ACS are plotted, to witness the good ability of the model to reproduce the actual operation of the gas cooler and of the ACS for a rather wide range of outdoor conditions typical of the summer season. Validation of the model for the “dry cooling” operation had already been done successfully (D’Agaro et al, 2019). The outdoor temperature and relative humidity are inputs for this model, and are taken from the monitored data.

3.2. Subcooling (SC)

Subcooling is based on the use of a heat exchanger at the exit of the gas-cooler/condenser and prior to the high pressure valve. The mass flow rate of chilled water supplied by the HVAC system is regulated depending on the outlet temperature at the gas cooler. Full opening is reached with 23 °C gas cooler outlet temperature, corresponding at about 19 °C outdoor air temperature. Fig. 3 depicts the temperature profiles of CO₂ inlet and outlet and of water inlet together with the water mass flow rate at the subcooler heat exchanger during week 3. Inoperative periods are characterized by null water flow.

It can be observed that chilled water that enters the subcooler exchanger is on average around 8-9 °C when the system is activated. Moreover, an important parameter that can be inferred from such data is the approach point of the subcooler which is around 7 K, parameter that allows modelling the exchanger with a method based on this number and on the maximum heat flow available, which depends on the size of the heat exchanger and is around 18 kW in this plant.

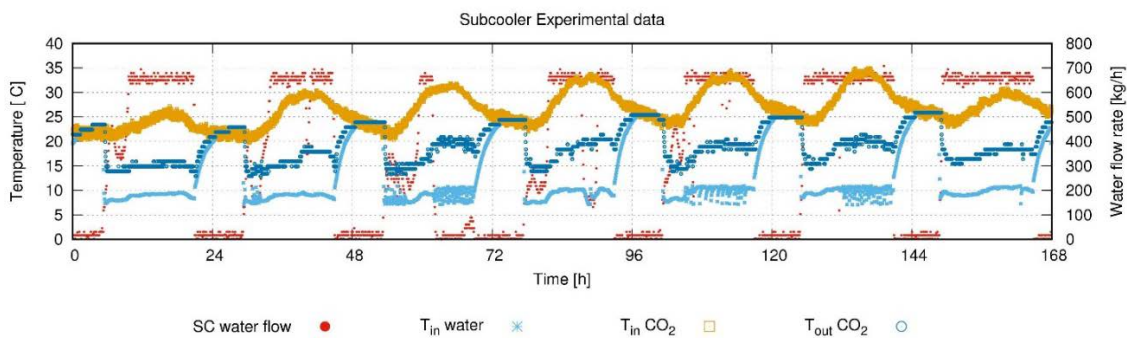

Figure 3: Temperature values at the subcooler and water flow rate in week 3

The subcooling degree ranges between 10 and 15 K, a value close to the optimum for single stage CO₂ systems at 25-30 °C outdoor temperature (Nebot-Andrés et al, 2017). When subcooling is performed, the HS pressure should be optimized in order to achieve the best efficiency of the system. Llopis et al (2015) showed that a significant reduction in the HS pressure would be suggested by optimization, and this would allow an increase in the COP around 2 % at the operating conditions here considered. However, given the complexity due to the interaction between the HVAC and the refrigerating plants, in the system considered the HS pressure was not optimized during SC operation.

The model seemed sufficiently reliable to reproduce the operation of the actual plant, even if a degree of uncertainty in the estimation of the subcooler operation was encountered, due to frequent and significant fluctuations in the inlet water temperature. A further analysis for a week with both the systems active has been carried out. The validation process also applied for this week, confirming the affordability of the model.

The model showed finally to be reliable enough in the prediction of the electric energy use, which is underestimated around 2.6 % due to the above mentioned temperature fluctuations in the actual plant.

4. YEARLY PERFORMANCE SIMULATIONS

The entire model that describes the CRU, the refrigerated cabinets and the heat recovery potential of the system had been already validated under different operating conditions (D’Agaro et al, 2019). With the analysis carried out in this work, further features have been added and validated with the

result of obtaining a CRU model usable to simulate different system layouts among which the subcooling (SC) and the Adiabatic Cooling System (ACS) and compare them in an annual timespan, with realistic cooling capacity profiles and actual outdoor conditions.

The results of this simulation apply to a mild weather typical of Northern Italy where the supermarket under exam is located. Simulations are carried out for a whole year with 15 minutes time step. The indoor conditions of the supermarket come from a thorough transient simulation of the thermal behavior of the building. Thus, the comprehensive model of the building developed in the framework of CommONEnergy (Dipasquale et al, 2016) has been integrated in the TRNSYS environment with the in-house routines of the display cabinets and CRU. The cases analyzed in this work are:

- REF: (reference case), CO₂ booster system;

with such features added to the reference case:

- PC: Parallel Compression
- ACS: Adiabatic Cooling System
- PC + ACS: Parallel Compression and Adiabatic Cooling System
- SC: Subcooler
- SC + ACS: Subcooler and Adiabatic Cooling System

ACS is activated when the outdoor temperature is equal or greater to 19°C, which is the lower limit of the transition zone between subcritical and trans-critical conditions (Polzot et al., 2016). Filippini et al. (2018) defined an activation rule of the ACS at 17 °C, which resulted from an economic optimization. In order to obtain a fair comparison, the same control rule is adopted for the SC, which is activated when the outdoor temperature exceeds 19 °C. The minimum subcooler outlet temperature for CO₂ is set at 15°C and the maximum heat extraction rate is 18 KW as it is in the real plant. The EER for the water chiller supplying subcooling is set in accordance with actual values of units available in the market and literature. For 2 °C evaporating temperature, the EER is

$$EER_{water\ chiller} = 5.629 - 0.0886 T_{out} \quad \text{Eq. (5)}$$

Chilled water at the inlet of the sub cooler is set at 8°C.

For the above mentioned reasons, no gas cooler pressure optimization is considered during SC operation. No heat recovery or AC supply to HVAC is considered.

As regards the cooling capacity, LT and MT loads are obtained from the simulation of the display cabinets and cold rooms. The integration between the refrigeration system and the building allows capturing the demand variation over the day and over the year because of the different set point values for the indoor temperature in the opening hours.

The electrical energy utilization of the CRU and of the entire system for a whole year, in the analyzed cases, is reported in Table 2.

Table 2. Annual electrical energy demand

	Annual Electrical Energy Demand [MWh]			Energy use vs REF [%]	Energy use vs PC [%]
	CRU	Subcooler	Total		
REF	132.5	-	132.5	0.0	-
PC	126.1	-	126.1	-4.8	0.0
ACS	119.3	-	119.3	-10.0	-5.4
PC + ACS	117.2	-	117.2	-11.5	-7.1
SC	119.9	7.9	127.8	-3.5	1.4
SC + ACS	114.6	4.2	118.8	-10.3	-5.7

The results, in terms of energy, are also presented on a monthly basis in the histogram of Fig. 4. Fig. 4 clearly shows that the performance enhancement methods yield benefits in the warm and hot months, when the system suffers trans-critical operation.

The parallel compression scheme with ACS offers the highest energy savings in this example of real CO₂ trans-critical booster system. But it can be observed that the key role is played by the ACS

rather than the parallel compressor. All cases where ACS is active yield total energy saving that are equal or higher than 10%. This is also due to the reduction in the HS pressure consequent to the lower temperature of CO₂ at the gas cooler outlet.

Another important aspect that should be examined regarding ACS is the activation temperature. The lower the activation temperature the higher are the energy savings on a yearly basis, due to a longer activation time. However, the advantages of the system decrease with low outdoor temperature, therefore this issue should be further investigated with an economical optimization approach.

Subcooling (SC) appears to be an energy saving solution and an effective alternative to parallel compression although the energy savings compared to PC show to be around 1% lower. The employment of chilled water from the HVAC plant implies a limit in the effectiveness of the subcooling system, given that a secondary fluid (water) is used and consequently the evaporating temperature is much lower with respect to a dedicated direct expansion subcooler. However, a significant saving in investment and maintenance costs makes this solution appealing. Reduction of the HS pressure through its optimization could lead to slightly higher benefit.

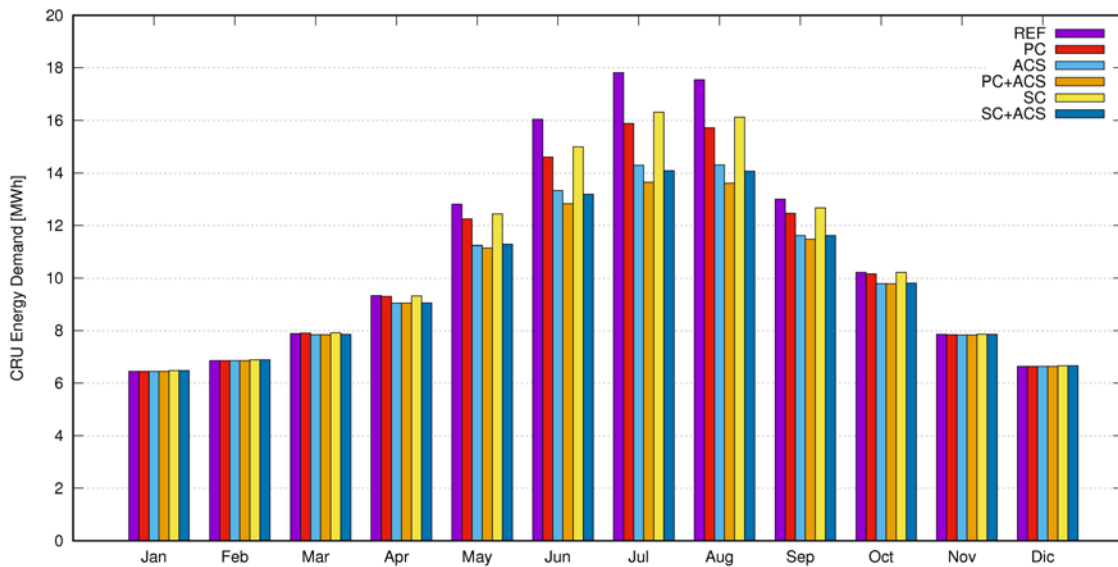

Figure 4. Monthly electrical energy demand.

The effect of the EER of the water chiller on the total energy consumption of the system has been investigated. Values 10 % and 20 % higher than those given by Eq. (4) have been considered for the cases SC and SC + ACS. The results are shown in Fig. 5, and demonstrate just a small reduction in the total energy consumption, which doesn't affect the considerations on the results.

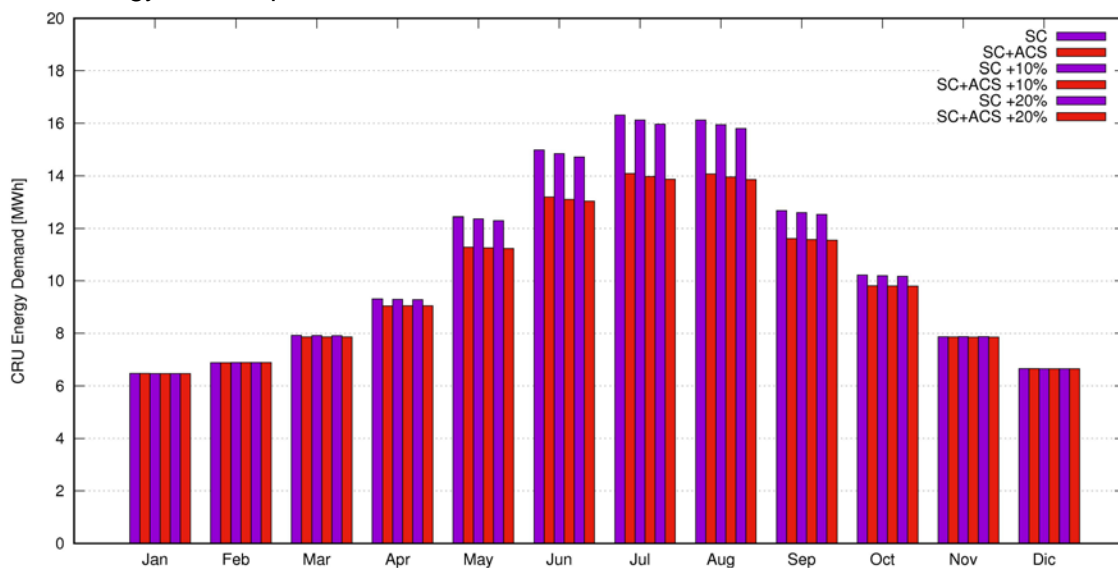

Figure 5: Monthly electrical energy demand, with increased EER values of the water chiller.

Finally, the effect of the maximum cooling capacity of the subcooler has been investigated, considering a couple of values below and above the chosen one for the simulations. The results (Table 3) show that the total value is almost constant, with a slightly lower value at 18 kW. Subcooling solution allows energy savings pretty close to the ones gained with the adoption of parallel compression.

Table 3. Influence of the SC cooling capacity

SC cooling capacity		Annual Electrical Energy Demand [MWh]				Energy use vs REF [%]	Energy use vs PC [%]
		CRU	Subcooler	Total			
	REF	132.5	-	132.5	0.0	-	
8 kW	SC	124.0	5.4	129.4	-2.3	2.7	
12 kW	SC	121.5	6.9	128.4	-3.0	1.9	
18 kW	SC	119.9	7.9	127.8	-3.5	1.4	

Fig. 6 represents both the experimental and simulated profiles of the CO₂ outlet temperature and of the heat flow at the subcooler for weeks 3 and 4. It appears that the maximum cooling capacity of the subcooler (18 kW in this case) is often exploited, without reaching the minimum CO₂ outlet temperature (15 °C). Therefore, the choice of the best subcooler capacity is a matter of balance between energy (and thus emissions) and cost benefits.

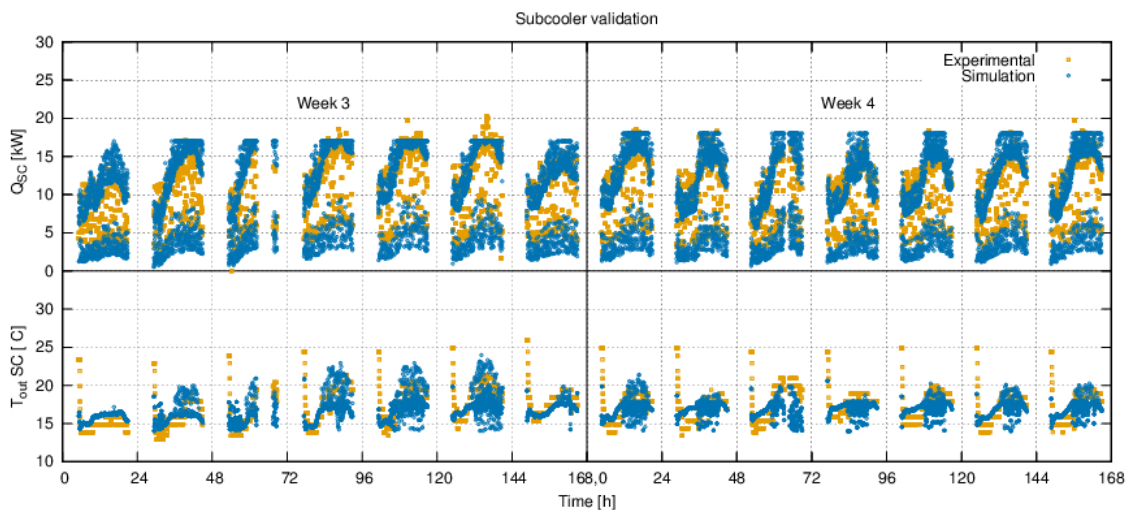

Figure 6: CO₂ outlet temperature and heat flow at the subcooler, weeks 3 and 4

5. CONCLUSIONS

Solutions to improve the efficiency of a CO₂ booster system for commercial refrigeration have been investigated, among parallel compression, subcooling and adiabatic cooling at the gas cooler. Subcooling was performed taking advantage of chilled water available at 7 °C from the HVAC system. For the system considered, and at its climate conditions, parallel compression and subcooling showed to be almost equivalent in terms of yearly energy use, while the adiabatic cooling system gave the best performance. This last solution in combination with parallel compression or subcooling can lead to about 10% energy saving compared to a basic booster cycle, while it allows reducing energy use by 7% compared to parallel compression alone. Comparisons revealed that the subcooler cooling capacity should be chosen carefully to avoid oversizing, while the influence of the EER for the chiller appeared quite small. Subcooling performed at the expense of an HVAC plant showed to be an interesting solution, great advantage was experienced with the employment of an adiabatic gas cooler.

ACKNOWLEDGEMENTS

The research leading to these results has received funding from the MIUR of Italy within the framework of PRIN2015 project «Clean Heating and Cooling Technologies for an Energy Efficient Smart Grid». EPTA Refrigeration is gratefully acknowledged for their continuous and precious assistance in gathering data, and for the fruitful discussions.

NOMENCLATURE

AC	Air Conditioning	HVAC	Heating, Ventilation, Air Conditioning
ACS	Adiabatic Cooling System	LS	Low Stage
app	Approach	LT	Low Temperature
CRU	Commercial Refrigeration Unit	MT	Medium Temperature
DHW	Domestic Hot Water	PC	Parallel Compression
EER	Energy Efficiency Ratio	T	Temperature (°C)
GC	Gas Cooler	RDC	Refrigerated Display Cabinets
HPV	High Pressure Valve	SC	Subcooling
HS	High Stage		

REFERENCES

- Bell, I.H, Wronski, J., Quoilin, S., Lemort, V., 2014. Pure and Pseudo-pure Fluid Thermophysical Property Evaluation and the Open-Source Thermophysical Property Library CoolProp. *Ind. Eng. Chem. Res.* 53(6), 2498-2508.
- Bush, J., Beshr, M., Aute, V. & Rademacher, R. 2017, "Experimental evaluation of transcritical CO₂ refrigeration with mechanical subcooling", *Science and Technology for the Built Environment*, vol. 23, no. 6, pp. 1013-1025.
- Cortella G., D'Agaro P., Coppola M.A., 2018. Simulations and field tests of a CO₂ refrigerating plant for commercial refrigeration, *Proc. 13th IIR Gustav Lorentzen Conference*, Valencia, 2018
- D'Agaro, P., Cortella, G., Polzot, A. 2018, R744 booster integrated system for full heating supply to supermarkets, *Int. J. Refrig.*, 96, 191-200.
- D'Agaro P., Coppola M.A., Cortella G., 2019. Field Tests, Model Validation and Performance of a CO₂ Commercial Refrigeration Plant Integrated with HVAC System. *Int. J. Refrig.*, 100, 380-391
- Dipasquale C., Belleri A., Lollini R., 2016. Integrative Modelling Environment, D 4.1 CommONEnergy. http://www.commonenergyproject.eu/uploads/deliverable/file/15/WP4_D4_1_20161124_P01_Integrative_Modelling_Environment_FINAL_v9.pdf [accessed 27.01/2018]
- Filippini, S., Mariani, G., Perrotta, L., Merlo, U., 2018. New CO₂ Gas Cooler for Dry and Wet Operation. *13th IIR Gustav Lorentzen Conference on Natural Refrigerants*, Valencia (E).
- Llopis, R., Cabello, R., Sánchez, D., Torrella, E., 2015. Energy improvement of CO₂ transcritical refrigeration cycles using dedicated mechanical subcooling. *Int. J. Refrig.* 55, 129–141.
- Llopis R., Nebot-Andrés L., Sánchez D., Catalán-Gil J., Cabello R., 2018. Subcooling methods for CO₂ refrigeration cycles. A Review. *Int. J. Refrig.*, 93, 85-107.
- Nebot-Andrés, L., Llopis, R., Sánchez, D., Catalán-Gil, J., Cabello, R. 2017, CO₂ with mechanical subcooling vs. CO₂ cascade cycles for medium temperature commercial refrigeration applications thermodynamic analysis, *Applied Sciences (Switzerland)*, 7(9) 955.
- Nebot-Andrés, L., Llopis, R., Catalán-Gil, J., Sánchez, D., Cabello, R. 2018, "Energy evaluation of the mechanical subcooling impact on a CO₂ DX-system in a commercial MT cabinet", *13th IIR Gustav Lorentzen Conference*, Valencia (E).
- Polzot, A., D'Agaro, P., Gullo, P., Cortella, G., 2015. Water storage to improve the efficiency of CO₂ commercial refrigeration systems, *24th IIR International Congress of Refrigeration*, Yokohama (JP), 2765-2772.
- Polzot, A., D'Agaro, P., Gullo, P., Cortella, G. 2016, Modelling commercial refrigeration systems coupled with water storage to improve energy efficiency and perform heat recovery, *Int. J. Refrig.*, 69, 313-323.