

# Dynamic shear tests of low-yield steel panel dampers for bridge bearing

T. Aoki, J. Dang & C. Zhang

Department of Urban and Environment, Aichi Institute of Technology, Toyota, Japan

T. Takaku

Toko Consultants Co Ltd, Tokyo, Japan

Y. Fukumoto

Professor Emeritus, Osaka University, Osaka, Japan

**ABSTRACT:** The dynamic behavior of low-yield point steel shear panel dampers under action of high speed loading is investigated experimentally in this paper. Horizontal displacement is applied by a 25tf hydraulic actuator at the panel top under the displacement control. Three patterns of sine wave vibration having a fixed displacement amplitude of  $\pm 18$  mm are applied to the panel top for the three different periods of  $T=0.5, 1.0$  and  $2.0$  sec. The effects of applied displacement velocity of loading on the load-displacement hysteresis loops approximately rectangular and practically rate independent of the shear damper are examined.

## 1 INTRODUCTION

A unified functional bearing system uses lead rubber bearing (LRB) which serves as both vertical bearing for gravity loads and lateral resistant device for seismic loads. LRB must be designed for all loads including seismic loads. A separated functional bearing system, on the other hand, consists of two separated bearings which are designed according to each separated functional requirement. One bearing supports the vertical force including dead and live loads, and another one serves as a shear panel damper for lateral seismic loads.

In the last years the writers developed a new shear panel damper made of low-yield steel (LYP-100) which possess high ductility and good seismic shear performance through the quasi-static cyclic loading tests and seismic bridge analysis for a five-span continuous girder bridge (Aoki et al 2007, 2008).

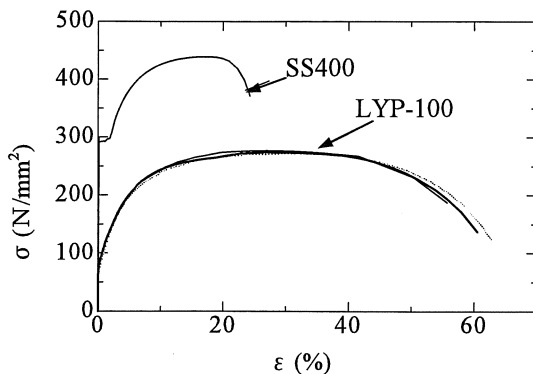

Figure 1. Stress-strain curves for SS400 and LYP100 tension coupons

This paper presents the hysteretic performance of the developed shear panel damper under dynamic loading. Horizontal displacement is applied by a hydraulic actuator on the top of the panel under displacement control. Shear panel specimens of  $156 \times 156 \times 6$  mm LYP 100 square web plate with vertical stiffeners are used for test. Three sine waves having the same amplitude of  $\pm 18$  mm with the three different periods of  $T= 0.5, 1.0$  and  $2.0$  sec. are applied to the panel top. Comparisons are made between the dynamic test results and the quasi-static cyclic test results, and failure panel modes under the dynamic loads are discussed.

## 2 CYCLIC SHEAR TEST OF SEISMIC DAMPERS

### 2.1 Test specimens, test setup and loading sequence of static test

Tensile coupon tests for low-yield 100(LYP-100)

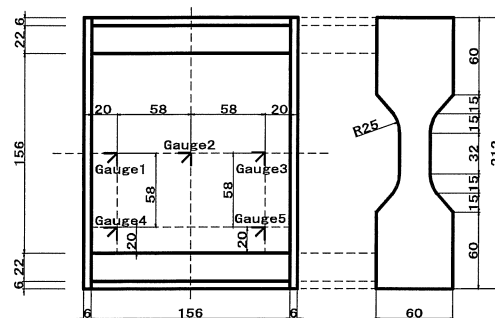

Figure 2. Specimen details and strain gauge locations

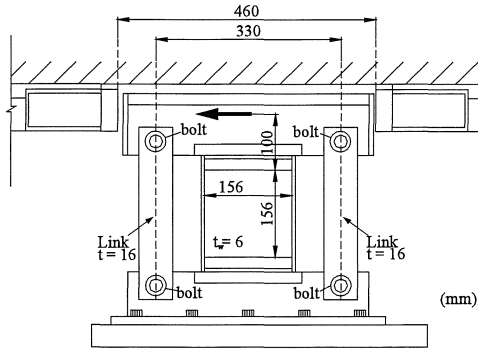

Figure 3. Specimen with link mechanism

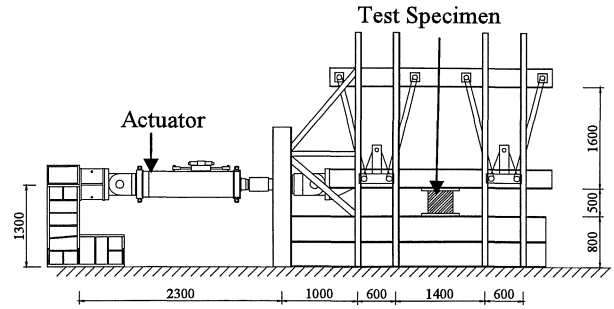

Figure 4. Test setup

steel were conducted and the obtained stress-strain curves are shown in Figure 1. The yield strength defined by the 0.2% offset value of LYP-100 is  $80.1 \text{ N/mm}^2$  and the elongation reaches 60%, which is about three times the value of SS400 mild steel.

Prior to dynamic test, a static cyclic loading test is performed for the same sized specimen. Shape of the specimen is shown in Figure 2. The specimen is square with the side length of 156mm and a uniform plate thickness of  $t=6 \text{ mm}$ . In order that the upper side can move horizontally, the upper plate is connected to the lower plate through links as shown in Figure 3. Cyclic lateral load was applied at the tip of the upper beam through a W-type leveling apparatus (Fig. 4).

The increments of the shear displacement in each loading cycle are  $\pm 5 \delta_y$ , where  $\delta_y = 0.42 \text{ mm}$  which is the shear yield displacement corresponding to the 0.2 % offset tensile yield stress. The displacement history is imposed on the specimen until failure. The test program is listed in Table 1 with the dynamic test program.

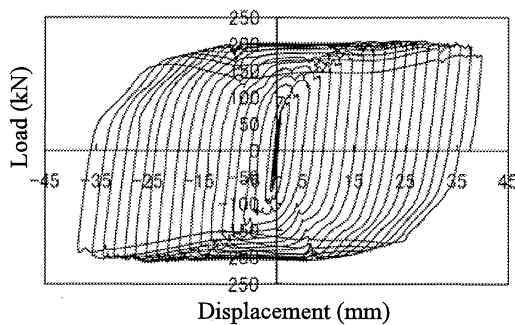

Figure 5. Hysteretic curve of static test

## 2.2 Test specimens, test setup and loading sequence of dynamic test

The three test specimens shown in Figure 2 are served for the dynamic tests under the sine wave loading with a same amplitude  $\Delta a = \pm 18 \text{ mm}$ , but different periods with  $T = 2.0, 1.0$  and  $0.5$  second, as shown in Table 1.

Loading setup for the dynamic test is the same for the static loading case as shown in Figures 3 and 4.

## 3 TEST RESULTS AND DISCUSSION

### 3.1 Static cyclic loading

The relationship of the horizontal load to the displacement is shown by the hysteretic curves in Figure 5, which is obtained from the static cyclic loading test. The maximum load in each cycle is increasing until to reach at 200kN in 11 cycles. The maximum load is held up to the 16<sup>th</sup> cycle. Then the

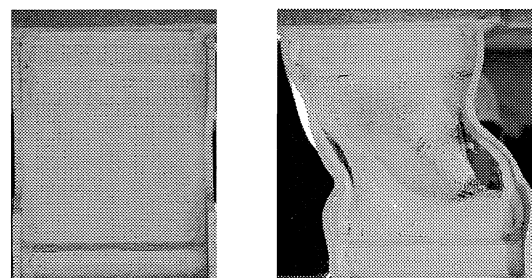

Photo 1. Comparison of specimen before and after static cyclic test

Table 1. Test program for static and dynamic cyclic loading

Specimen	Sin Wave	Displ. Amplitude $\Delta a$	Mean Loading Velocity	Mean Shear Strain	Shear Strain Velocity
	Period				
	sec	mm	mm/sec	%	1/sec In %
LYSP-S	Static	—	—	—	—
LYSP-D20	2	$\pm 18$	36	$\pm 11.5$	23.1
LYSP-D10	1	$\pm 18$	72	$\pm 11.5$	46.2
LYSP-D05	0.5	$\pm 18$	144	$\pm 11.5$	92.3

\* $\gamma = 18/d = 0.115$ ,  $d = b = 156 \text{ mm}$ ,  $t = 6 \text{ mm}$ ,  $\tau_y = 46.2 \text{ N/mm}^2 = \sigma_y / \sqrt{3}$

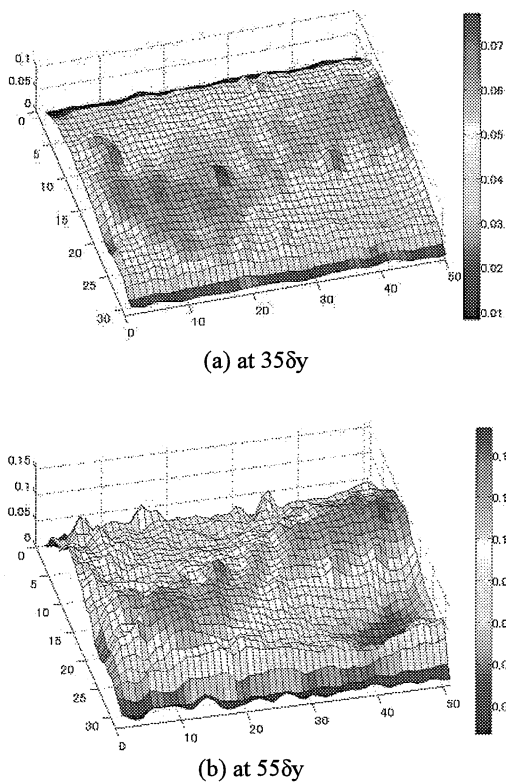

Figure 6. Strain by image processing

stiffness and the maximum load are gradually reduced due to the low cycle fatigue of the panel and the shear buckling along with the out-of-plane deformation.

The maximum displacement of the final cycle reaches to  $95 \delta_y$  ( $=40\text{mm}$ ), which is equivalent to the average shearing strain of 26%. It can be said from this test result that this damper has a very large deformation capacity compared with conventional shear type dampers.

The shapes of panel specimen before and after test are shown in Photo 1. It can be seen from the final destruction shape shown in Photo 1(b) that crack appears along the welding lines of ribs in both sides. It is observed during the cyclic loading that the cracks were caused by the repeated out of plane bending of the plate due to local buckling deformation. As the welding was performed well, it may be said that the cause of the defect shouldn't attribute to the welding. Therefore it may be said that the thickness of panel plate should be thick enough to prevent repeated local buckling deformation to avoid such cracks.

To find optimum width to thickness ratio for the shear panel under cyclic loading may become significant subject to obtain higher seismic performance.

The shear strain distribution on the whole area of the panel is measured by the image processing (Aoki et al 2007) at  $35 \delta_y$  and  $55 \delta_y$  are shown in Figure 6. It

is observed from this figure that strain distributes uniformly at  $35 \delta_y$ , whereas the diagonally stretched deformation can be seen in the  $55 \delta_y$  caused by the thin plate.

### 3.2 Dynamic cyclic loading

The relationship of the horizontal load to the displacement up to the 11<sup>th</sup> cycle is shown by the hysteretic curves as shown in Figures 7, 8 and 9 for the sine wave periods of 2.0 sec, 1.0 sec and 0.5 sec together with the displacement history. Figures show that the load-displacement hysteretic loops are approximately rectangular with the same maximum load of 190 kN for three cases. This maximum load of 190 kN can reach to 200 kN obtained by the static cyclic loading test for LYSP-S.

In the test of LYSP-D20 (loading period 2.0 Sec.), the displacement amplitude of +18 mm at the 1<sup>st</sup> cycle reduces to +15 mm and then settled into stable curves after the 2<sup>nd</sup> cycle. In the third test of LYSP-D05 (loading period 0.5 Sec.) which is the highest velocity case, the cyclic displacement amplitude remained 15mm because of the actuator being controlled by the inside displacement meter. Therefore it is better to measure the displacement of the test specimen directly by an externally installed meter to feed the prescribed displacement accurately in the high speed dynamic loading.

During strong earthquake, the recorded major oscillatory motions are usually of around 10 cycles. The present dynamic test results that the hysteretic loops for the three specimens are stable up to 11 cycles without big change of forms in every loop and can be applicable to use as a reliable damper.

### 3.3 Performance of panel specimen beyond 11 cycles in dynamic loading

Figure 10 shows the whole hysteretic loops from the 1<sup>st</sup> cycle up until failure of the specimens. It can be seen from this figure that the resistance force (horizontal load) of the panel after 11 cycles deteriorates gradually along with increasing of the displacement amplitude. The number of cycles of each specimen until failure falls in between 30 and 40 cycles.

There is a clear difference of the force-displacement loops between the two cycle domains, that is, the first one is within 11 cycles and the second one beyond 11 cycles. In the second domain, the panels began to generate heat gradually due to the internal friction caused by the high speed repeated loading. White painted color on plate surface changed to brown with smoking. Significant heat initiated at the center of panel and spread around during the high speed cyclic loading (see Photo 2). Although accurate temperature was not measured, it could be assumed at least 500 deg. C.

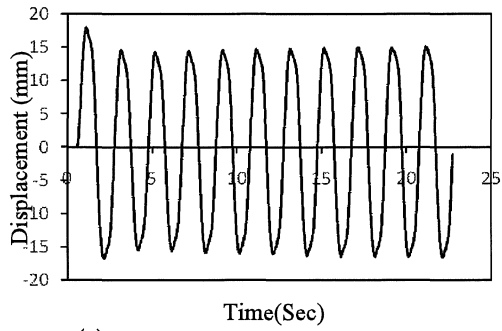

(a) Time history of displacement

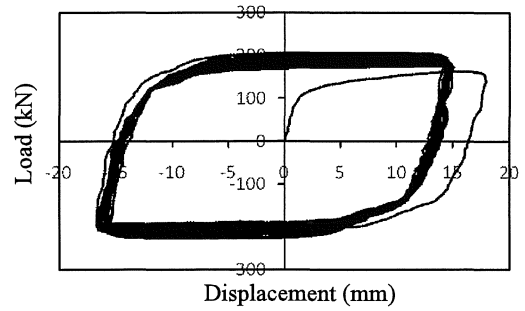

(b) Hysteretic curve

Figure 7. LYSP-D20, period 2.0 second

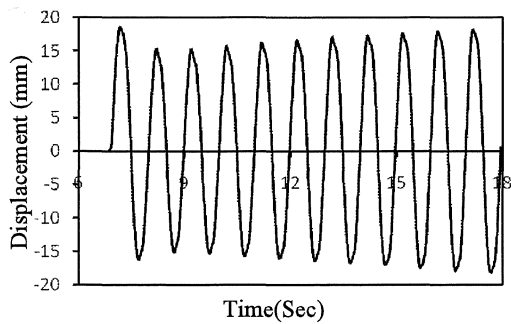

(a) Time history of displacement

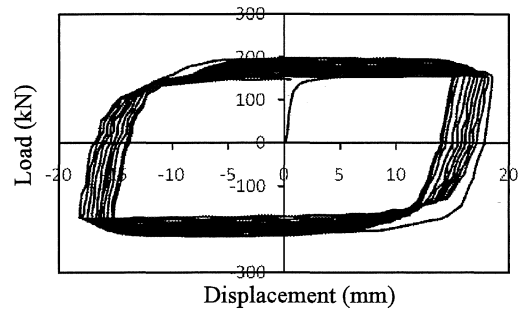

(b) Hysteretic curve

Figure 8. LYSP-D10, period 1.0 second

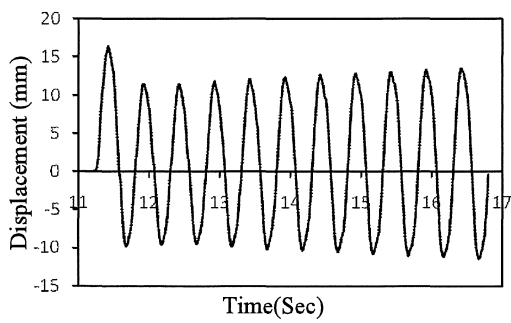

(a) Time history of displacement

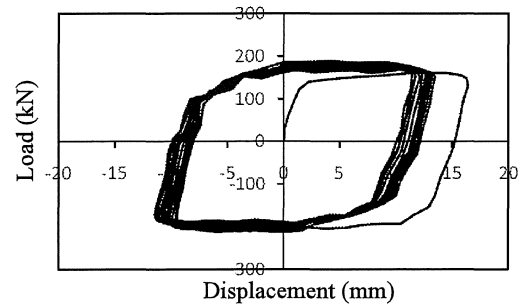

(b) Hysteretic curve

Figure 9. LYSP-D05, period 0.5 second

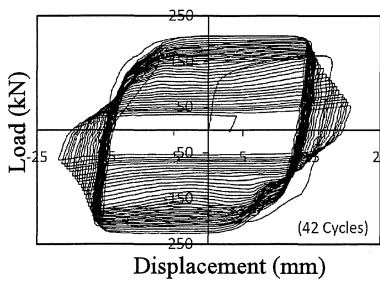

(a) LYSP-D20

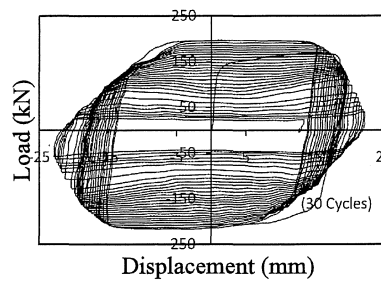

(b) LYSP-D10

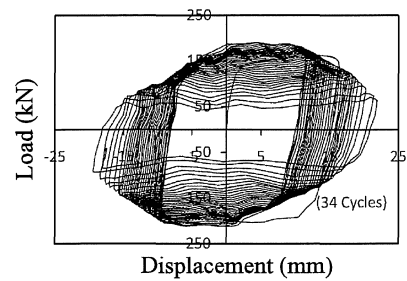

(c) LYSP-D05

Figure 10. Whole hysteretic curve

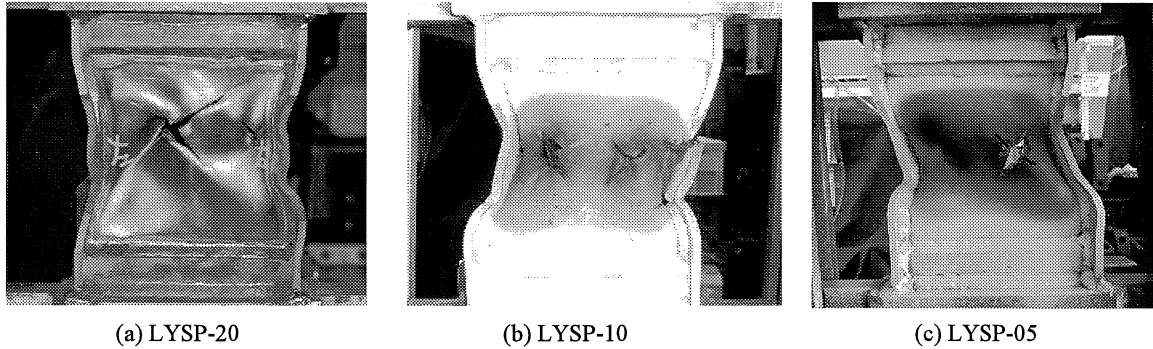

Photo 2. Specimens after test

The high thermal distribution may cause softening of steel and shear stiffness due to the degraded elastic and plastic moduli along with the number of cycles. High temperature may cause the premature shear buckling and deteriorate the horizontal resistance along with the number of cycles.

As shown in Photo 2, the heat generated zone becomes rectangle. The shear buckling mode having two half-waves occurred in the soften zone. The alternate shear buckling waves occurred from the left part to the right part or vice versa by the cyclic loading, which cause cracks of two X shapes on the right and left of the middle area of the panel as seen in Photo 2.(b) and (c). LYSP-20 (loading period of 2.0 sec), which is the slowest loading speed, showed a similar buckling mode between dynamic and static cyclic tests.

The change of buckling mode due to heat generation is a very interesting phenomenon that can not be observed in the static cyclic loading test with slow loading speed. When the number of major shaking during strong earthquake goes beyond 10 cycles, or when the response displacement becomes large and its speed is high, the performance of shear panel made of low yield steel could be deviate from the effect of the static cyclic test due to the high generated heat.

#### 4 CONCLUSIONS

This paper presented an experimental study examining the hysteretic performance of the shear panel dampers under high speed dynamic loading. The test specimen response was obtained successfully and was consistent with the expected performance for the shear dampers. The high speed dynamic loading test was conducted at the first time at the Earthquake Research Center of the Aichi Institute of Technology.

The main conclusions of this study are:

1) The force-displacement hysteretic loops are approximately rectangular up to 11cycles, and the

loops are of practically rate independent at the period of 0.5 sec to 2 sec for the corresponding shear strain of 12%.

2) After 11 cycles the horizontal force starts to decrease significantly due to the alternate shear buckling and diagonal tension field of the plate until to the remaining cycles of failure.

3) The specimens left a burnt domain in the middle of the plate and expand the domain under the high speed loading as shown in Photo 2. Different failure modes are obtained for the three dynamic specimens depending on the loading speed and thus the developed heat degree.

4) Significant heat developed in the shear panel during the high speed loading. The thermal distribution may cause the premature buckling due to the degraded elastic and plastic moduli. With increasing temperature the annealing process occurs in the specimens.

Further study is needed for the mechanical properties and stability of the LYP steel plate at the elevated temperatures.

#### REFERENCES

- Aoki, T., Liu, Y., Takaku, T., Ueno, M & Fukumoto, Y. 2007. Experimental investigation of tapered shear-type seismic devices for bridge bearings. *Proc., 8<sup>th</sup> Pacific Structural Steel Conference (PSSC), New Zealand, March 2007*, 1, 111-117.
- Aoki, T., Liu, Y., Takaku, T. & Fukumoto, Y. 2008. Development of hysteretic shear damper for seismic steel bridge. *Proc. 5<sup>th</sup> EUROSTEEL, Graz, Austria, September 2008*.
- Dusicka, T., Itani, A.M. & Buckle, I.G. 2007. Cyclic response of plate steels under large inelastic strains. *Journal of Constructional Steel Research* 63:156-164.
- Nakashima, M. 1995. Strain-hardening behavior of shear panels made of low-yield steel. I: Test. *Journal of Structural Engineering, ASCE* 121, 1995.12: 1742-1749.
- Saeki, E., Sugisawa, M., Yamaguchi, T. & Wada, A. 1998. Mechanical properties of low yield point steels. *Journal of Materials in Civil Engineering, ASCE* 10, 3: 143-152.