



UWS Academic Portal

The effect of short-term feed-deprivation and moult status on feeding behaviour of the Pacific white shrimp (*Litopenaeus vannamei*)

Bardera, Guillermo; Owen, Matthew A. G.; Pountney, Daniel ; Alexander, Mhairi E.; Sloman, Katherine A.

Published in:
Aquaculture

Published: 15/09/2019

Document Version
Peer reviewed version

[Link to publication on the UWS Academic Portal](#)

Citation for published version (APA):

Bardera, G., Owen, M. A. G., Pountney, D., Alexander, M. E., & Sloman, K. A. (2019). The effect of short-term feed-deprivation and moult status on feeding behaviour of the Pacific white shrimp (*Litopenaeus vannamei*). *Aquaculture*, 511, [734222].

General rights

Copyright and moral rights for the publications made accessible in the UWS Academic Portal are retained by the authors and/or other copyright owners and it is a condition of accessing publications that users recognise and abide by the legal requirements associated with these rights.

Take down policy

If you believe that this document breaches copyright please contact pure@uws.ac.uk providing details, and we will remove access to the work immediately and investigate your claim.

THE EFFECT OF SHORT-TERM FEED-DEPRIVATION AND MOULT STATUS ON FEEDING BEHAVIOUR OF THE PACIFIC WHITE SHRIMP (*Litopenaeus vannamei*).

Guillermo Bardera¹, Matthew A.G. Owen², Daniel Pountney², Mhairi E. Alexander¹, Katherine A. Sloman¹

¹Institute of Biomedical and Environmental Health Research (IBEHR), School of Health & Life Sciences, University of the West of Scotland, Paisley, PA1 2BE, United Kingdom.

²Skretting Aquaculture Research Centre (ARC), Stavanger, 4016, Norway.

Abstract

There is increasing recognition of the need to understand behaviours of species important in aquaculture to facilitate their production. This is particularly true of species where variations in feeding behaviours may impact cultivation costs. The Pacific white shrimp (*Litopenaeus vannamei*) is the most cultivated species in crustacean aquaculture globally, however, there are few studies that have addressed its feeding behaviour in detail. The objective of the present study was to evaluate the feeding behaviour of *L. vannamei* in response to feed-deprivation treatments and moult status. In this study, twenty-four juvenile shrimp (10.51 ± 2.17 g) were divided across three different feed-deprivation conditions (+0 h (control), +24 h or +48 h; n=8 per treatment). All shrimp started from a baseline of 14 h feed-deprivation; all individuals had their last food intake at 19.00. Those in the control group were recorded for behaviour at 09.00 the following day and were not feed-deprived for any additional time (+0 h), whereas the other treatments were feed-deprived by one (+24 h treatment) or two (+48 h treatment) extra days. Moult status was monitored as it changed in all shrimp throughout the course of the experiment. Shrimp, provided with their usual food, were observed individually *via* video in test arenas for 20 minutes where feeding behaviours were recorded. Each shrimp was recorded 5 times across different days, providing information on within-individual in addition to between-individual variation. Filmed observations on individual shrimp showed a clear prevalence of feeding activity in groups that were feed-deprived for +48 h compared to the other treatments. Shrimp that were feed-deprived for +24 h also showed significantly increased feeding activity compared to the control group. Shrimp in the inter-moult stage had significantly increased feeding activity. Longer feed-deprivation reduced both within- and between-individual variation across the majority of the behaviours that were scored. Repeatability analyses were performed and also supported this finding, with greater repeatability of behaviours in shrimp that were feed-deprived for +48 h. Thus, it was shown that feed-deprivation and moult status have significant effects on *L. vannamei* feeding behaviour. The results of this study highlight the relevance of feed-deprivation and moult status in nutritional trials and provide important baseline information for developing the use of behaviour to improve *L. vannamei* production.

Key words: Attraction to feed, Feeding activity, Individual variation, Inter-moult, Penaeid shrimp.

1. Introduction

There is a growing recognition of the relevance of understanding behaviours of species important in aquaculture. Studying the behaviour of animals for production can provide accurate indicators for assessing welfare (Martins *et al.*, 2012), evaluating husbandry techniques (Almazán-Rueda *et al.*, 2004) and feed management protocols (Andrew *et al.*, 2004; Noble *et al.*, 2007; Sánchez *et al.*, 2009). Behaviours can be useful in offering a quick and non-invasive indication of changes in the environment (Hazlett, 1995; Sih *et al.*, 2004; Dingemans *et al.*, 2010) however most of the advances in aquaculture in this area have been applied to finfish production with fewer studies conducted in other aquaculture industries such as shrimp production.

An area of shrimp aquaculture which is likely to benefit from understanding behaviours of cultivated species is feeding (Bardera *et al.*, 2018). Several studies have documented a range of feeding inefficiencies associated with shrimp production (e.g. Davis *et al.*, 2006; Smith and Tabrett, 2013), which have been partly attributed to slow feeding activity by individuals (Ullman *et al.*, 2019). In penaeid shrimp, searching, detection and grasping of food are guided by different sets of chemoreceptors (Steiner and Harpaz, 1987; Derby and Sorensen, 2008), and a variety of behavioural repertoires have been observed in relation to chemical detection of food and feeding stimulation (Lee and Meyers, 1996). When feed is offered, shrimp change their behavioural profile by increasing the frequency of behaviours related to searching, such as exploration and crawling. This is matched with decreases in the frequency of unrelated behaviours, such as inactivity, cleaning and burrowing (Pontes and Arruda, 2005; Silva *et al.*, 2012).

An important factor that is likely to affect feeding behavioural repertoires and may potentially influence attraction to feed of shrimp, as well as in other farmed animals, is variation in hunger levels and the effect of feed-deprivation (Costero and Meyers, 1993). Often, in nutritional studies where different feeds or feed components are trialled to determine preference or feeding attraction, crustaceans are feed-deprived for a period of 18-24 h prior to testing (e.g. Holland and Borski, 1993; Sanchez *et al.*, 2005; Nunes *et al.*, 2006; Derby *et al.*, 2016). However, crustacean feeding activity and behavioural responses may change with feed-deprivation time and subsequently influence the results obtained (Lee and Meyers, 1997; Sanchez *et al.*, 2005). Feed-deprivation has been studied in several penaeid species (e.g. Cuzon *et al.*, 1980; Chandumpai *et al.*, 1991; Rosas *et al.*, 1995; Stuck *et al.*, 1996; Comoglio *et al.*, 2004), however, these studies have mainly focussed on physiological and biochemical effects and, to our knowledge, no one has yet considered the influence of feed-deprivation on behaviour.

A further factor that is likely to affect feeding behaviours of shrimp is the moult status of individuals (Dall *et al.*, 1990). Moulting can have substantial effects on overall activity (such as locomotion and swimming) but is particularly important in feeding (Chan *et al.*, 1988). Indeed, penaeids have been observed to suppress feeding activity in the preliminary stages before and after moulting (Dall, 1986; Harpaz *et al.*, 1987; Chan *et al.*, 1988; Dall *et al.*, 1990; Vega-Villasante *et al.*, 2000). Importantly, depending on their moult stage, shrimp can show more or less sensitivity to stress (Wajsbrot *et al.*, 1990), and this can be an additional influence on their overall behaviour (Heales *et al.*, 1996), potentially contributing to individual variation

in crustacean feeding behaviour. In addition, due to phenotypic constraints in sensory capabilities, morphological limitations or limits on learning abilities, variation in behavioural plasticity between and within individuals in the same population can occur (Hazlett, 1995; DeWitt *et al.*, 1998; Wilson, 1998; Briffa *et al.*, 2008, 2015; Briffa and Sneddon, 2016). These individual differences will affect feeding behaviours, and understanding individual variation is also likely to be of importance in species that are the focus of aquaculture.

One of the most important shrimp species in global aquaculture is the Pacific white shrimp *Litopenaeus vannamei* which represents more than 70% of the world shrimp cultivation (FAO, 2018). The success in production of this species is a result of a number of factors, including its tolerance to high densities, high average daily growth rates, and its ability to withstand a large range of water parameters (Briggs *et al.*, 2004; Bondad-Reantaso *et al.*, 2012; Jory and Cabrera, 2012). However despite being such an important species in global production, there are few studies documenting its behaviour, in particular with regards to feeding (but see Nunes *et al.*, 2006; Lima *et al.*, 2009; Da Costa *et al.*, 2016). This is surprising given that an important constraint in *L. vannamei* production is the high feeding costs that are associated with this species (Hung and Quy, 2013) and the slow feeding rates that are also observed (Costero and Meyers, 1993; Peñaflores and Virtanen, 1996).

As feed-deprivation and moult status are likely to be crucial factors in determining feeding behaviour in penaeid shrimp and may affect overall levels of between- and within individual variation in behaviour, the aim of the present study was to evaluate feeding behaviour and individual variation in *L. vannamei*. Different types of behaviours including state behaviours, event behaviours and attraction-to-feed were observed repeatedly in individual shrimp in relation to different feed-deprivation times (+0 h, +24 h, +48 h) and moult status stages (inter-moult, pre-moult, post-moult) to understand the effects of these conditions on behaviours in *L. vannamei*. It is envisaged that the results from this work will be of benefit to our understanding of the fundamental feeding behaviour of *L. vannamei* and can help inform future behavioural feed trials to improve the aquaculture of this globally valuable species.

2. Material and Methods

2.1. Shrimp husbandry

Juvenile Pacific white shrimp *Litopenaeus vannamei* were obtained from The Fresh Shrimp Co. (Newcastle, United Kingdom) in July 2017 and maintained in two closed 300 l recirculation systems at the University of the West of Scotland (Paisley, United Kingdom). Each recirculation system was composed of three holding tanks (60 x 37 x 40 cm, length x width x depth) and a sump tank (65 x 50 x 39 cm). Aeration was provided within all the system tanks. Artificial seawater (Seamix, Peacock salt) was passed through a UV filter and parameters in the holding tanks were 30 ± 1 ppt salinity, $26.2 \pm 0.4^\circ$ C temperature, > 5 mg/l dissolved oxygen and 7.7 ± 0.2 pH (mean \pm S.E.). Approximately 22 *L. vannamei* juveniles were allocated to each holding tank during the acclimation period and were held for 18 days before experiments started. Photoperiod was maintained at 12 h light/12 h dark. Before use in experiments, shrimp were fed *ad libitum* (~ 10% ration of tank biomass) a 57% crude protein

diet (Gemma Diamond 1.0, Skretting France) equally divided across three feeding sessions per day (09.00, 13.00 and 19.00). Excess food and faeces were removed after each feeding.

Individuals of 10.51 ± 2.17 g (mean \pm S.E.) body mass and with all appendages in good condition were selected from holding tanks for use in experiments. Twenty-four experimental shrimp were selected and moved to an additional 220 l recirculation system with four holding tanks (59 x 34 x 18 cm) and a sump tank (65 x 50 x 39 cm), with water treatment and parameters as before. Shrimp were placed inside individual circular mesh chambers (diameter 18 cm). The circular chambers were then divided between the four holding tanks (six in each). Eight shrimp were allocated to each of the three feed-deprivation treatments (detailed below), such that each holding tank contained two chambers from each treatment. Shrimp were acclimated inside the circular mesh chambers for 5 days before any feed-deprivation was begun prior to experimental trials. Shrimp were fed individually following the same protocol as in the holding tanks (i.e. 10% of their biomass per day, equally divided across three feeding sessions).

2.2. Experimental design and feeding regime

The 24 shrimp were divided across three feed-deprivation treatments, each with eight individuals; +0 h (control), +24 h and +48 h feed-deprivation groups. As behavioural trials were conducted in the morning (9.00-12.00), the control group was recorded for behaviour 14 h after they last fed (i.e. at 19.00 the previous day) and so provided a feed-deprivation baseline. Food was withheld from the +24 h treatment for an additional 24 h (thus they experienced a total of 38 h of feed-deprivation prior to behavioural trials) and from the +48 h treatment group for an additional 48 h (a total of 62 h prior to behavioural trials). Five repeated behavioural trials were recorded on each individual shrimp 3 days apart, thus the experimental design could be used to examine overall differences among treatment groups as well as variation between- and within-individuals. Moulting was also monitored throughout the experiment to investigate the influence of moult status (inter, pre, post) on shrimp behaviour.

2.3. Behavioural trials

For behavioural trials, test arenas were constructed using polycarbonate (95 cm x 30 cm x 15 cm (length x width x depth); Fig. 1). Arenas comprised an acclimation chamber (**A**; 10 cm x 30 cm x 15 cm) that was opened by lifting a separating door at the start of the trial to allow shrimp access to the rest of the arena. At the far end of the test arena a feeding tray (**B**; 6 cm x 6 cm x 1 cm) was positioned where the feed was dispensed. At the end of the test arena, an isolated chamber (**C**; 10 cm x 30 cm x 15 cm) contained a Gopro Hero 3+ camera to record shrimp feeding activity inside the feeding tray. A 1 cm² grid was placed under the bottom surface of the maze to provide a correct scale for videos and to aid in analysis. In addition to the GoPro camera within the maze, a video camera (Canon G15) was set-up directly above to record the entire system.

For each behavioural trial, the test arena was filled with 25 l of fresh artificial sea water (parameters as in the recirculation system), which was replaced with new sea water for each subsequent trial. During each recording, no water current was generated to avoid the influence of rheotaxis on the animal's orientation towards the food source and affect the quality of video

recordings. Arena walls were also covered with black plastic to minimize disturbance to shrimp. At the start of the trial, individual shrimp were transferred from their circular mesh chamber and placed in the acclimation chamber and, after 10 minutes, the separating door was removed so that the shrimp could explore the arena. The same feed that they received in the holding tanks (1 g, 57% crude protein diet Gemma Diamond 1.0, Skretting France) was added to the feeding area at the same time that the shrimp was placed in the system to reduce all possible disturbances after acclimation. For recording of trials, both video cameras were turned on at the point the separating door was removed, and the shrimp was filmed for 20 minutes for analysis of behaviour (see below). In the week prior to experimental trials, the shrimp had been introduced to the test arena for 20 minutes on three separate occasions, in the same way as in the experiments, to allow them to become familiar with the arena. The same feed type and quantity was also provided during these acclimation trials.

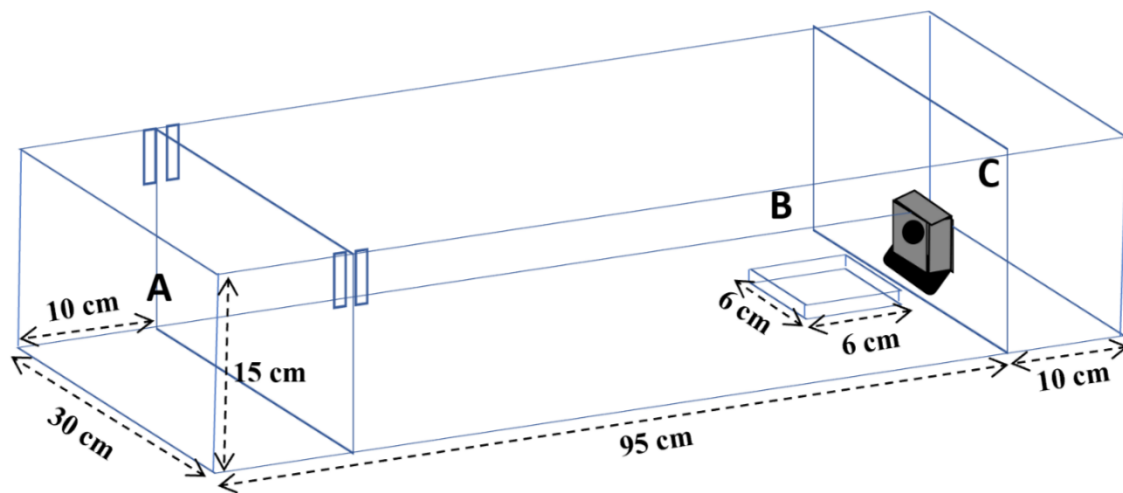

Figure 1. Dimensions of test arena where shrimp were recorded. Test arena was composed of: A = acclimation area, B = feed area, C= camera area.

2.4. Behavioural units

An ethogram was developed for shrimp feeding behaviour based on the responses proposed by Lee and Meyers (1996) (Table 1). Video analysis of behaviours was performed using BORIS v. 6.0.1 software (Friard and Gamba, 2016).

Inactivity, detection, orientation, locomotion, fleeing and feeding were recorded as mutually exclusive ‘state behaviours’ (Table 1a), accounting for the whole-time budget (i.e. 1200 seconds). These state behaviours were further classified as ‘passive’ or ‘active’ depending on whether shrimp were moving. In addition, maxilliped beat, eye beat, and antennae wipe were also recorded as ‘event behaviours’ (Table 1b). Instead of duration of time, these behaviours were recorded as counts and could be performed at the same time as the ‘state behaviours’.

Table 1. Ethogram of *Litopenaeus vannamei* adapted from Lee and Meyers (1996). Two kinds of behaviours are identified: (a) State Behaviours which are mutually exclusive, in total accounting for the

whole time budget; (b) Event Behaviours are independent of each other, being recorded as frequencies and not included in the overall time budget.

		Behaviour	Description
a) State Behaviours	Passive behaviours	Inactivity	Shrimp is in a steady position without any movement of its appendages.
		Detection	Movement of shrimp appendages, such as mouthparts, antennules, antennae, pereopods in a steady position.
		Orientation	Shrimp movement to orientate side-on to feed without changing the position of their middle point.
	Active behaviours	Locomotion	Shrimp movement forward or backward with position change.
		Fleeing	Vigorous movements against the wall of the experimental maze associated with swimming behaviour.
		Feeding	Shrimp positioned on the feeding tray, eating food.
b) Event Behaviours	Maxilliped beat	Shrimp beats and strokes maxillipeds.	
	Eye beat	Shrimp beats eyes against themselves.	
	Antennae wipe	Shrimp wipes antennae.	

2.5. Statistical analysis

Statistical analysis was performed using R software v. 3.4.3 and IBM SPSS Statistics v.25.

2.5.1. Behavioural differences in relation to feed-deprivation and moult status

Data obtained from video analysis were log transformed to achieve normality. Differences in all considered behaviours within each feed-deprivation treatment and moult status were analysed using a Generalised Linear Model (GLM), where feed-deprivation/moult status was treated as a between factor and each behaviour was treated as a within-factor. Shrimp ID was included as a random factor in the model to account for repeated observations owing to each

individual contributing data to each of the moult stages. It should be noted that whereas feed-deprivation treatment was assigned ($n=8$), moult status was dependent on the shrimp that went through their natural moulting cycle during the experiment; this was accounted for in the statistical model. All 24 shrimp used in the present study went through all three moult stages (pre-moult, inter-moult, post-moult), but the number of videos of each individual shrimp was lower for the post-moult stage due to the shorter length of this stage. This made a total of nine possible categories of shrimp status (i.e. three feed-deprivation states x three moult stages). Due to violation in sphericity, Greenhouse-Geisser or Huynh-Feldt corrections were applied. Where overall significant effects were found, tests of simple effects were performed followed by post hoc tests. Post hoc analyses were performed using the Tukey test to analyse differences between feed-deprivation or moult status treatments and Bonferroni pairwise comparisons were performed to check differences between the behaviours analysed. Significant differences were noted when $p < 0.05$.

2.5.2. Correlation of state behaviours

Pearson's correlation analysis was performed on the state behaviours, using all the video recordings that were observed with respect to feed-deprivation and moult status as separate data points. There were five videos taken per shrimp (i.e. repeats over time) thus there were 120 video recordings in total. The correlations looked for overall relationships between the different behaviours to identify whether any of them were closely correlated with time spent feeding. A positive correlation indicates a positive relationship between two behaviours (i.e. a high level of one behaviour is correlated with a high level of the other behaviour), whereas a negative correlation between two behaviours indicates that one behaviour is being carried out at the expense of the other.

2.5.3. Attraction-to-feed score

Attraction-to-feed score was calculated as the time taken by an individual to reach the feeding tray for the first time in a trial divided by the total trial time (i.e. 1200 seconds) and then expressed as a percentage. Values for the attraction score therefore ranged from 0-100% where higher values represent greater attraction. Differences in this score were analysed according to feed-deprivation group and moult status again using a GLM with feed-deprivation/moult status as a between factor and the attraction-to-feed score as a within-factor. Again, shrimp ID was included as a random factor in the model to account for repeated observations owing to each individual contributing data to each of the moult stages. Due to violation in sphericity, Greenhouse-Geisser or Huynh-Feldt corrections were applied. Where overall significant effects were found, tests of simple effects were performed followed by post hoc tests. Post hoc analyses were performed using the Tukey test to analyse differences between starvation or moult status treatments. Significant differences were noted when $p < 0.05$.

In addition, a regression analysis was performed to validate whether the attraction-to-feed score was a predictor of overall time spent feeding. Even though shrimp that initially moved to the feeding tray quickly clearly had more time available in the trial to feed, early arrival at the feeding station would not necessarily mean the remaining trial time would be spent feeding, as the shrimp could leave the feeding station straight away.

2.5.4. Between- and within- individual variation

We investigated the effect of feed-deprivation on between and within-individual variation in state behaviours and attraction-to-feed score by determining the consistency (i.e. repeatability) in the behaviour of individuals. To achieve this, we performed univariate mixed-effects models using the R package *lme4* (Bates *et al.*, 2014). We analysed the consistency of shrimp behaviour using starvation as a fixed factor. It was not possible to run this analysis according to moult status due to a low sample size in some groups. We included the proportion of available time spent performing each behaviour as the dependent variable, running separate mixed-effects models for each behaviour in turn with shrimp identity included as a random factor (Zuur *et al.*, 2009). We then calculated the intraclass correlation coefficients (or repeatabilities) from the model outputs by dividing the between-individual (i.e. V_{ind_0}) variance by the total variance (i.e. $V_{ind_0} + V_{e_0}$; where V_{e_0} is the average within-individual plasticity towards any stimulus that is statistically unaccounted for) (Dingemanse and Dochtermann, 2013). We used this output to determine whether the time spent by an individual in each of the behaviours was repeatable, that is whether a larger portion of the total variance can be attributed to differences between individuals rather than within individuals (Nakagawa and Schielzeth, 2010; Dingemanse and Dochtermann, 2013, Cleasby *et al.*, 2015). To calculate confidence intervals (95% CI) we used parametric bootstrapping with 1000 simulations using the R package 'rptR' (Stoffel *et al.*, 2017). Repeatability estimates were deemed insignificant if the lower estimate of the confidence interval approached zero (i.e. <0.1) (Houslay and Wilson, 2017).

In addition, a visual interpretation of the individual variation results was conducted through the calculation of coefficients of variation (CV), for both the feed-deprivation and moult status groups. The CV is a statistical measure of the dispersion of data points around a mean value, with higher values indicating greater levels of variation. It is calculated by dividing the standard deviation of the data series in question by its mean (i.e. $CV = SD / \text{mean}$). Data grouped by feed-deprivation treatments were considered initially, followed by those grouped by moult status, but only between-individual variation was analysed in relation to moult status due to low sample size in the post-moult group.

3. Results

3.1. Behavioural differences in relation to feed-deprivation and moult status

Significant main effects of feed-deprivation ($F_{5,173} = 4.350$, $p < 0.01$) and moult status ($F_{5,173} = 4.776$, $p < 0.001$) were found in relation to state behaviours. However, with regards to event behaviours, only moult status presented a significant effect in the model ($F_{2,99} = 3.199$; $p < 0.05$). As no significant interaction between feed-deprivation and moult status was found for either state or event behaviours, the main effects of each condition were analysed independently in relation to the observed behaviours.

Feed-deprivation: Overall, a significant difference in the time spent performing each state behaviour was found ($F_{2,49} = 11.032$, $p < 0.001$) with a significant interaction between feed-deprivation period and behaviours performed ($F_{5,49} = 3.108$, $p < 0.018$, Fig. 2a). Shrimp from the

control group spent more time inactive and performing detection behaviours than any of the other behaviours ($F_{3,95}=47.507$, $p<0.001$). However, with an increase in feed-deprivation period, the differences between passive and active behaviours disappeared (Fig. 2a). When the time spent performing the same behaviour was compared between treatment groups, behaviours that were influenced by feed-deprivation treatment included inactivity ($F_{2,63}=4.092$, $p<0.05$), detection ($F_{2,63}=10.343$, $p<0.001$) and feeding ($F_{2,63}=6.312$, $p<0.01$). Tukey post hoc analysis showed significant differences between control and +48 h feed-deprivation groups in relation to inactivity ($p<0.05$) and between the control and the other feed-deprivation groups for detection (+24 h, $p<0.01$; +48 h, $p<0.001$) and feeding (+24 h, $p<0.05$; +48 h, $p<0.01$; Fig. 2a).

A significant effect of feed-deprivation was also found in the performance of event behaviours ($F_{2,27}=39.516$, $p<0.001$; Fig. 2b). Differences in the number of times that shrimp exhibited these behaviours were also found within the control ($F_{2,62}=1.947$, $p<0.001$), +24 h ($F_{2,64}=24.476$, $p<0.001$) and +48 h ($F_{2,63}=30.528$, $p<0.001$) feed-deprivation groups, with a greater number of antennule wipes than eye and maxilliped beats (Fig. 2b). However, no significant differences were found within each of the event behaviours according to feed-deprivation periods.

Moult status. In general, a significant difference in the time spent performing each state behaviour was found ($F_{2,177}=19.240$, $p<0.001$). A significant interaction between moult status and behaviour was also observed ($F_{5,177}=4.269$, $p<0.01$, Fig. 2c) and there was a difference in the time spent performing different behaviours for each of the three moult status groups (inter-moult: $F_{2,43}=6.195$, $p<0.01$; pre-moult: $F_{2,57}=10.303$, $p<0.001$; post-moult: $F_{2,45}=11.135$, $p<0.001$). Post-moult shrimp spent most of the time performing passive behaviours and fed for significantly less time in comparison to the rest of behaviours ($p<0.01$ all). However, this difference between passive behaviours and feeding was not seen in pre-moult or inter-moult shrimp, where those behaviours were more equally distributed across the recording time. (Fig. 2c). When each behaviour was compared between moult status, only time spent feeding was significantly different ($F_{2,63}=15.030$, $p<0.001$), with inter-moult shrimp spending more time feeding than pre-moult ($p<0.05$) and post-moult ($p<0.001$) shrimp. In addition, pre-moult shrimp spent more time feeding than post-moult shrimp ($p<0.05$) (Fig. 2c).

Differences were found in the frequency of event behaviours ($F_{2,121}=50.223$, $p<0.001$), with a significant effect of moult status ($F_{2,121}=3.007$, $p<0.05$; Fig. 2d). Inter-moult ($F_{2,28}=28.972$, $p<0.001$) and post-moult ($F_{2,46}=19.805$, $p<0.001$) performed a higher number of antennae wipes compared to eye and maxilliped beats, whereas pre-moult individuals ($F_{2,46}=12.540$, $p<0.001$) exhibited a lower number of eye beats in comparison to the other two behaviours (Fig. 2d). Moreover, when each behaviour was compared between moult status, a significant difference was found in relation to the number of eye beats ($F_{2,63}=6.250$, $p<0.01$) and antennae wipes ($F_{2,63}=5.743$, $p<0.01$; Fig. 2d). Tukey tests showed that post-moult shrimp performed a higher number of eye beats in relation to pre-moult ($p<0.01$) and inter-moult ($p<0.05$) shrimp. Post-moult shrimp also performed a higher number of antennae wipes compared to pre-moult ($p<0.01$) and inter-moult ($p<0.05$) shrimp (Fig. 2d).

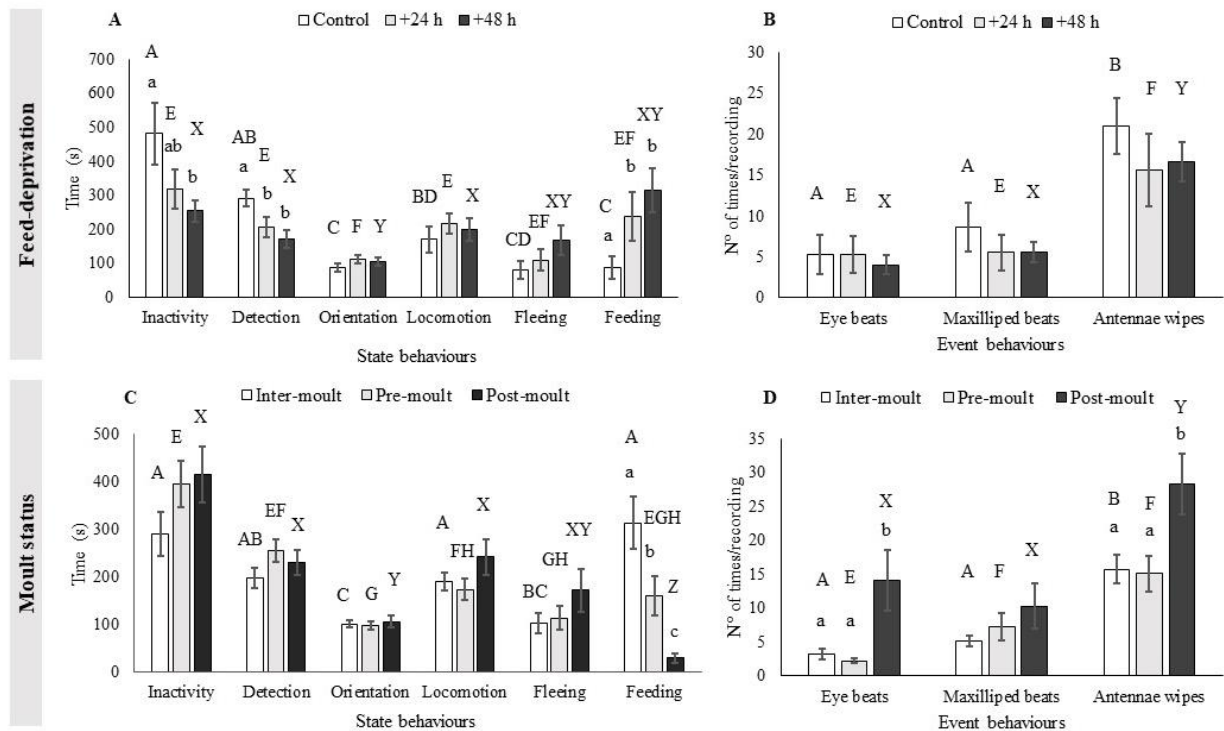

Figure 2. Average time (s) performing each state behaviour and event behaviour according to feed-deprivation (A, B; n=8 shrimp per feed-deprivation treatment) and moult status (C, D; n= 24 shrimp per moult status because each shrimp went through all three moult stages thus bars represent repeated measurements on the same individuals). Presented with standard errors. Significant differences (Tukey: $p < 0.05$) in time spent performing different behaviours by animals within the same treatment are indicated by capital letters, where bars sharing a letter are not statistically different. The absence of letters indicates no significant differences were found within that treatment. Significant differences (Tukey: $p < 0.05$) between treatments within the same behaviour are indicated by lowercase letters and the absence of letters indicates no significant differences between treatments for that behaviour were found.

Correlation between analysed behaviours

The time budget of shrimp changed according to both feed-deprivation period and moult status (Table 2). There was a general trend where feeding behaviour was negatively correlated with the rest of the behaviours measured. However, for feed-deprivation, only inactivity was significantly negatively correlated with feeding behaviour in the control group (-0.414 , $p < 0.001$) whereas all behaviours showed a significant negative correlation with feeding at +24 h and +48 h feed-deprivation (Table 2). For moulting, there were no behaviours which were significantly negatively correlated with feeding in the post-moult group and in the pre-moult group, negative correlations with feeding reached significance with inactivity (-0.551 , $p < 0.001$) and detection (-0.348 , $p < 0.05$). All behaviours showed a significant negative correlation with feeding in the inter-moult group (Table 2).

Table 2. Correlation coefficient (r) between the different behaviours and feeding using all the video observations made (120 behavioural observations) considered in relation to (A) feed-deprivation periods (control, +24 h, +48 h (n=8 shrimp per treatment and 5 video observations per shrimp = 40 videos per treatment)) and then (B) moult status. The number of videos of each individual shrimp was not the same for each moult stage due to the differences in the length of each stage, therefore there were 52 behavioural observations of inter-moult shrimp, 44 of pre-moult shrimp and 24 of post-moult shrimp). Significant correlations are shown in bold and indicated as *p<0.05, **p<0.001. Shaded cells represent negative correlations with feeding behaviour.

A				B		
Feeding	Control	+ 24 h	+ 48 h	Inter-moult	Pre-moult	Post-moult
Inactivity	-0.414**	-0.580**	-0.513**	-0.572**	-0.551**	-0.234
Detection	-0.143	-0.369*	-0.349*	-0.448**	-0.348*	-0.125
Orientation	0.002	-0.485**	-0.312*	-0.425**	-0.134	0.169
Locomotion	0.087	-0.444**	-0.431**	-0.424**	-0.107	0.230
Fleeing	-0.178	-0.393*	-0.500**	-0.454**	-0.162	0.066

Attraction-to-feed score

Significant differences in the attraction-to-feed score were found in relation to feed-deprivation treatment ($F_{2,63} = 3.817$, $p < 0.05$; Fig. 3a) and moult status ($F_{2,63} = 4.374$, $p < 0.05$; Fig. 3b). The +48 h feed-deprivation group and the inter-moult status had the highest attraction-to-feed scores, and were significantly different from the control and post-moult groups, respectively (Tukey's test: $p < 0.05$ both comparisons).

Moreover, the time spent feeding by individual shrimp could be strongly predicted by their attraction-to-feed score ($R^2 = 0.615$, $p < 0.001$; Fig. 3c). Shrimp that had the highest attraction-to-feed score and therefore longer feeding times were predominantly from the +48 h feed-deprivation group whereas the shrimp with the lowest attraction-to-feed score were from the control group. Shrimp feed-deprived for +24 h were distributed along the attraction-to-feed range (Fig. 3c).

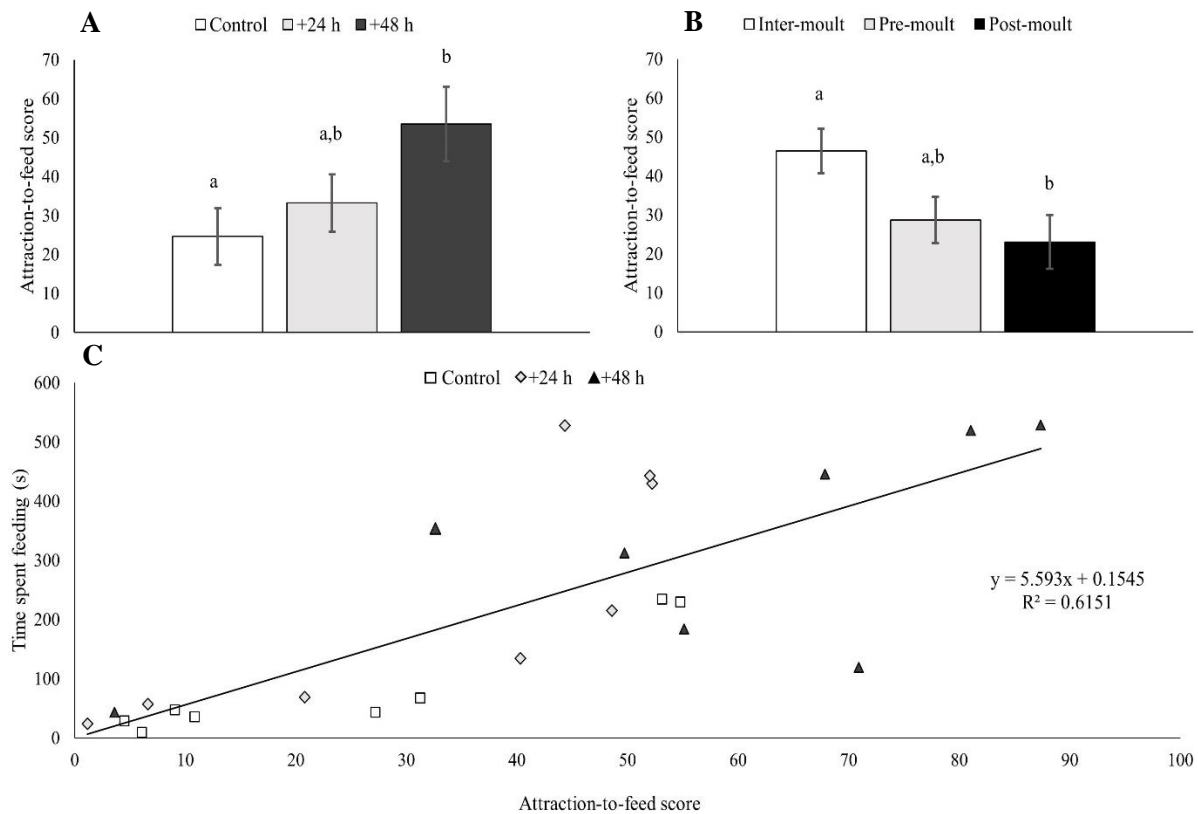

Figure 3. Attraction-to-feed score (%) of shrimp according to feed-deprivation periods (A; n= 8 shrimp per feed-deprivation treatment) and moult status (B; n= 24 shrimp per moult status because each shrimp went through all three moult stages, thus bars represent repeated measurements on the same individuals). Presented with standard errors. Significant differences (Tukey: $p < 0.05$; lowercase letters) were found according to feed-deprivation periods between control and +48 h feed-deprivation and between inter- and post-moult individuals in relation to moult status. (C) Correlation between the attraction-to-feed score of each individual and the time spent feeding. Feed-deprivation groups are identified by symbols; squares = control, diamonds = +24 h feed-deprivation, triangles = +48 h feed-deprivation (n= 8 per feed-deprivation treatment).

Between- and within-individual variation

Analysis of repeatability with respect to feed-deprivation groups revealed significant differences in behavioural consistency across treatments (Table 3). Significant repeatability was found in the two passive behaviours considered here, inactivity and detection, across all the feed-deprivation treatments, with the control group presenting the highest repeatability in both behaviours. This contrasts with the active behaviours of orientation and fleeing which were not found to be significantly repeatable across any of the feed-deprivation groups. With regards to feeding, only individuals in the +48 h feed-deprivation group showed significant repeatability of time spent engaging in this behaviour. In addition, behavioural consistency in attraction to feed and locomotion was seen in shrimp starved for +24 h and +48 h (Table 3).

These results for the effect of feed-deprivation time are further illustrated in the CV analysis (Fig. 4), which support the results presented by the repeatability analysis. For the passive

behaviours examined, there appears to be an increase in between-individual variation at the greater feed-deprivation periods illustrated by increasing CV values. In contrast, with increasing feed-deprivation periods, active behaviours showed a general decrease in between- and within individual variation, illustrated by the CV data for both feeding and attraction.

As mentioned above, it was not possible to include moult status in the full repeatability analysis as it was not possible to determine within-individual variation due to the short time each individual shrimp spent in post-moult phase. However, analysis of between-individual variation (Fig. 5) revealed a reduction in variation in all active behaviours when shrimp were in inter-moult status. Although there was no clear pattern in the influence of moult status on the CV for passive behaviours, shrimp in inter-moult presented the highest CV values.

Table 3. Repeatability estimates for measured behaviours according to feed-deprivation groups. Units for mean are the proportions of time spent performing each behaviour (n= 8 shrimp per treatment). Repeatability was calculated from univariate mixed-effects models with shrimp identity included as a random effect. Parametric bootstrapping was used to calculate confidence intervals (95% CI). Significant repeatability estimates are shown in bold.

Behaviour	Starvation	Mean	Range	Repeatability (95% CI)
Inactivity	Control	0.40	(0.05 – 0.92)	0.54 (0.25 – 0.66)
	+24 h	0.26	(0.03 – 0.76)	0.27 (0.16 – 0.37)
	+48 h	0.21	(0 – 0.77)	0.19 (0.15 – 0.27)
Detection	Control	0.24	(0.07 – 0.44)	0.23 (0.20 – 0.29)
	+24 h	0.17	(0.01 – 0.39)	0.16 (0.12 – 0.22)
	+48 h	0.14	(0.02 – 0.34)	0.14 (0.10 – 0.19)
Orientation	Control	0.07	(0 – 0.20)	0.07 (0.05 – 0.10)
	+24 h	0.09	(0.02 – 0.19)	0.09 (0.07 – 0.11)
	+48 h	0.09	(0.02 – 0.17)	0.10 (0.07 – 0.11)
Locomotion	Control	0.14	(0 – 0.45)	0.17 (0.08 – 0.21)
	+24 h	0.18	(0.04 – 0.48)	0.19 (0.13 – 0.23)
	+48 h	0.12	(0.01 – 0.50)	0.24 (0.11 – 0.32)
Fleeting	Control	0.07	(0 – 0.22)	0.11 (0.08 – 0.13)
	+24 h	0.09	(0 – 0.57)	0.13 (0.08 – 0.15)
	+48 h	0.14	(0.01 – 0.50)	0.13 (0.07 – 0.21)
Feeding	Control	0.07	(0 – 0.65)	0.09 (0.03 – 0.11)
	+24 h	0.20	(0 – 0.87)	0.17 (0.07 – 0.32)
	+48 h	0.25	(0 – 0.89)	0.30 (0.14 – 0.36)
Attraction	Control	0.25	(0 – 0.91)	0.28 (0.09 – 0.40)
	+24 h	0.33	(0 – 0.88)	0.33 (0.18 – 0.48)
	+48 h	0.49	(0 – 0.96)	0.42 (0.31 – 0.66)

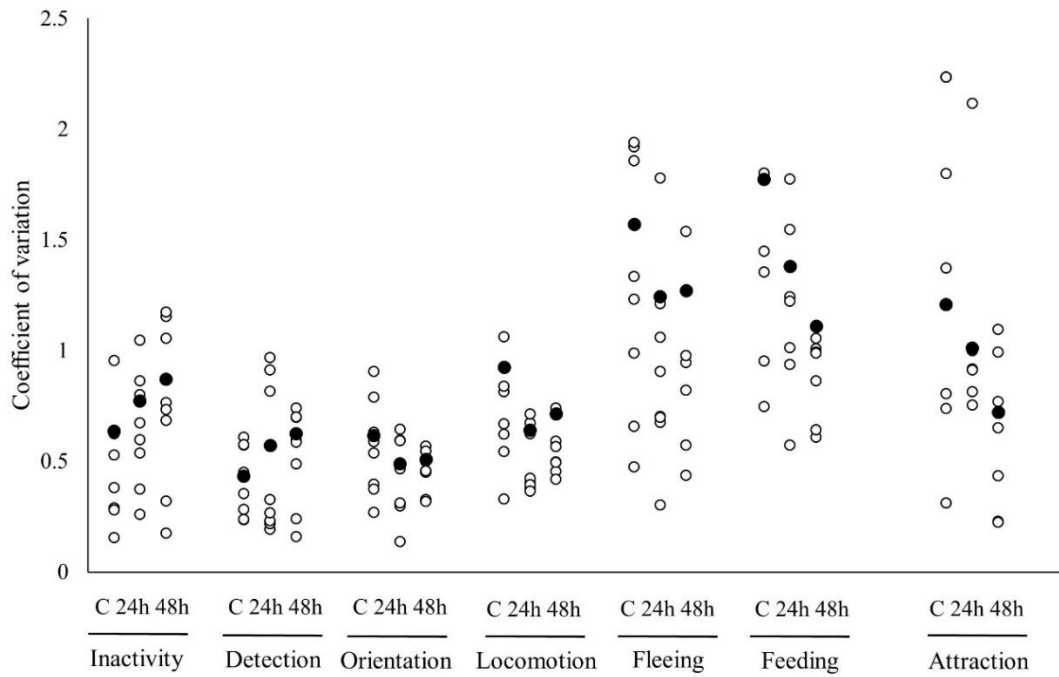

Figure 4. Coefficient of variation for between-individuals (black circles) and within-individuals (white circles) with respect to time spent performing state behaviours (inactivity, detection, orientation, locomotion, fleeing and feeding) and attraction-to-feed score (%). Data are for control shrimp (C), +24 h and +48 h treatments (n= 8 per treatment, N.B. some data points overlap).

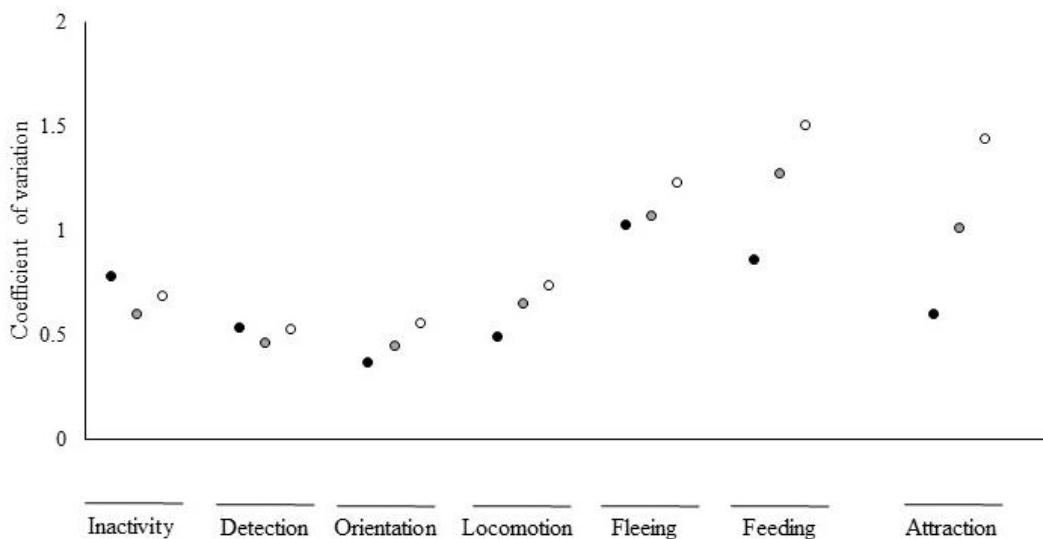

Figure 5. Coefficient of variation for between-individuals in inter-moult (black circles), pre-moult (grey circles) and post-moult status (white circles) with respect to time spent performing behaviours (inactivity, detection, orientation, locomotion, fleeing and feeding) and attraction-to-feed score (n= 24 shrimp per moult status because each shrimp went through all three moult stages thus bars represent repeated measurements on the same individuals).

4. Discussion

Although there has been a growing recognition of the importance of understanding animal behaviours in aquaculture, less attention has been focused towards certain species that are important in production, such as shrimp. This study therefore addressed this knowledge gap by investigating behaviours in a globally important species in crustacean aquaculture, the Pacific white shrimp *L. vannamei*, by specifically examining the effect of two conditions, feed-deprivation and moult status, on feeding behaviours. Results indicated that *L. vannamei* adjusts its behavioural repertoire and feeding attraction significantly according to different feed-deprivation periods and at different stages in the moulting cycle. This therefore has potential implications for our understanding of behaviours in aquaculture settings where individuals are likely to exhibit differences in physiological state.

In this study we found that shrimp with additional feed-deprivation periods (i.e. +24 h, +48 h) presented a significant increase in feeding and a decrease in inactivity and detection in comparison to the control group. Similarly, individuals that were in inter-moult showed the greatest levels of feeding. Hence, feed-deprivation and moult status are important factors that should be properly controlled when nutritional studies are carried out. A number of studies that have shrimp feeding as a central component, for example those that investigate nutrition, have fasted experimental shrimp for 18-24 h (e.g. Holland and Borski, 1993; Sanchez *et al.*, 2005; Nunes *et al.*, 2006; Derby *et al.*, 2016; Silva *et al.*, 2019) and used individuals in the same moult status (e.g. Sanchez *et al.*, 2005; Smith *et al.*, 2005). However, this is not always common practice and the results presented here suggest this to be an important consideration.

Of the limited studies conducted on *L. vannamei*, changes in feeding behaviour have been noted according to different conditions. It has been shown that *L. vannamei* has higher feeding levels during dark periods and more inactivity in the light (Pontes *et al.*, 2006) and shrimp fed seven times per day (i.e. not feed-deprived), also presented higher levels of inactivity (Lima *et al.*, 2009). In fact inactivity has been noted as the first behaviour to decrease when feed is offered (Silva *et al.*, 2012). In the present study, when feed was available throughout behavioural trials, passive, low energy, behaviours (i.e. inactivity, detection) (Da Costa *et al.*, 2016), prevailed in shrimp from the control treatment and post-moult status, where the lowest levels of feeding activity were observed. In addition, inactivity was negatively correlated with feeding across all feed-deprivation and moult groups, with stronger negative correlations in the more feed-deprived or inter-moult shrimp. Passive behaviours, therefore, appear to be a useful first indication of low feeding motivation.

Event behaviours as studied here (i.e. eye beat, maxilliped beat and antennae wipe) have not been considered in previous studies of *L. vannamei* behaviour. Our results indicated that feed-deprivation time had no effect on the occurrence of these behaviours, however significant differences were found in relation to moult status. Post-moult shrimp displayed a higher frequency of eye beats and antennae wipes compared to pre- and inter-moult shrimp. Shrimp close to ecdysis (i.e. at the end of pre-moult and post-moult phases) are more susceptible to stress (Wajsbrodt *et al.*, 1990) and so it is possible that the increase in these behaviours in post-moult shrimp is a reflection of stress. Observations of mouthpart beating (such as maxilliped beats as investigated here) have been previously documented in other crustaceans such as the

Caribbean spiny lobster (*Panulirus argus*) and can be linked to antennular grooming behaviour (AGB) or auto-grooming (Barbato and Daniel, 1997; Wroblewska *et al.*, 2002). This is where crustaceans clean their mouthparts using their pereopods or beat them energetically to remove chemical particles from the antennules. Levels of AGB may differ depending on the chemical attractant used (e.g. Zimmer-Faust *et al.*, 1984; Barbato and Daniel, 1997; Daniel *et al.*, 2001). In the present study, no significant differences in the frequency of maxilliped beats were found in relation to starvation or moult status, possibly because only one type of feed was used during the experiment. Future studies could focus more on this behaviour to investigate if there is the same connection between AGB and attractants in penaeid species.

Attraction towards food has been studied in previous experiments to assess shrimp choice between different experimental feeds. Hartati and Briggs (1993) assessed attractiveness according to the number of *L. vannamei* shrimp on feeding trays containing different diets and the time spent feeding. Smith *et al.* (2005) calculated attraction in relation to the preference between different experimental diets and a base diet in tanks containing 12 Asian tiger shrimp (*Penaeus monodon*) juveniles. Nunes *et al.* (2006) used a similar approach to the present study, calculating the orientation and locomotion time that individual shrimp required to reach an area containing food within a Y-maze that presented the shrimp with a choice between two different diets. In the present study, feed-deprivation and moult status significantly affected the attraction-to-feed score, with shrimp deprived of feed for +48 h and in inter-moult status showing the quickest approach to the feeding area. However, a fast approach to the feeding tray and interaction with feed does not necessarily result in extended feeding times, as shrimp can stop feeding after arriving at the tray. Whether shrimp remain to feed at the feeding tray will depend on food-acceptance or rejection behaviour as previously documented in other crustacean species such as the giant river prawn (*Macrobrachium rosenbergii*) (Steiner and Harpaz, 1987) and the hermit crab (*Pagurus granosimanus*) (Wight *et al.*, 1990). In the present study, a positive correlation was found between feeding activity and the attraction-to-feed score, suggesting that shrimp arriving quickly to the feeding tray were more motivated to feed. This is perhaps not surprising as only one type of feed was used during this experiment and was the diet that the shrimp had been previously fed on. It remains to be determined whether the relationship between attraction-to-feed and feeding behaviour in Pacific white shrimp is influenced by other types of feed. Indeed, it may be possible to use the strength of relationship between attraction-to-feed and time spent feeding to assess feed quality and this idea warrants further investigation. Regardless, our results clearly show that in developing parameters for feeding trials, periods of feed deprivation and moult status have significant effects on shrimp feeding behaviour that need to be carefully considered.

Individual variability is an important consideration for behavioural studies (Dingemanse and Dochtermann, 2013; Briffa and Sneddon, 2016; Hewes and Chaves-Campos, 2018). Behavioural variation between- and within-individuals of the same species which have been subjected to similar conditions could indicate that behavioural plasticity is affected by different conditions such as morphological limitations, sensory capabilities, limits on learning abilities or genetic components (Hazlett, 1995; DeWitt *et al.*, 1998; Briffa *et al.*, 2015; Briffa and Sneddon, 2016). Such limits on behavioural plasticity may result in consistent differences in behaviour in individuals from the same population, affecting the likelihood of generating

inconclusive results in a study (Briffa *et al.*, 2008; Dingemanse and Dochtermann, 2013). In the present study, individual variation in relation to feed-deprivation was investigated using repeatability analysis. Passive behaviours became less consistent (i.e. lower repeatability values) and active behaviours (e.g. feeding) became more consistent (i.e. higher repeatability values) as shrimp were feed-deprived for longer. These findings were further supported by the results obtained from the CV analysis which showed a tendency towards reduction in the between- (for both feed-deprivation and moult status) and within-individual (for feed-deprivation only) variation in active behaviours when shrimp were in inter-moult status and more feed-deprived.

Previous work on behavioural consistency has found similar findings in other crustacean species. For example, hermit crabs (*Pagurus bernhardus*) (Briffa *et al.*, 2008) and big hand crabs (*Heterozius rotundifrons*) (Hazlett and Bach, 2009) were tested several times to determine individual variation in relation to predator defence behaviour. Individuals differed in their defence behaviour but presented high levels of individual consistency across conditions. Alexander *et al.* (2015) found a reduction in between-individual variation in feeding behaviour in marine amphipods (*Echinogammarus marinus*) when individuals were feed-deprived for longer. However, within-individual variation increased with longer feed-deprivation time. In penaeid shrimp, Santos *et al.* (2016) found that *L. vannamei* can increase behavioural consistency in relation to feeding activity under constant conditions. Furthermore, these results reflect how important feed-deprivation and moult status are in the reduction of individual variation and this may have important implications for future behavioural studies. The presence of repeatability in several behaviours measured in the present study tentatively suggests the existence of animal personality in *L. vannamei* (Briffa and Weiss, 2010), a term that explains these consistent differences in individual behaviour. This concept has been addressed in other crustacean species (Briffa *et al.*, 2008; Bridger *et al.*, 2015; Hewes and Chaves-Campos, 2018) but not in penaeid shrimp, thus presents an interesting avenue for future research.

5. Conclusion

The results presented here suggest that feed-deprivation and moult status have a significant effect on *L. vannamei* feeding behaviour with important implications for the design of future behavioural and feed choice trials. The highest levels of feeding and reduced levels of individual variation were found in shrimp that were feed-deprived for an additional 48 h, and in inter-moult. Passive behaviours (i.e. inactivity, detection) were correlated with low feeding motivation. Using a favourable diet, attraction-to-feed score was an effective method of assessing levels of feeding activity and was also influenced by feed-deprivation and moult status. Additionally, repeatability of some of the analysed behaviours may provide evidence of animal personality in penaeid shrimp, although further research is required. We have identified the importance of considering feed-deprivation and moult status when investigating feeding behaviours of Pacific white shrimp, providing important baseline information in developing the use of behaviour to improve Pacific white shrimp production.

Acknowledgments

Currently removed due to double-blind peer review process.

References

Alexander, M.E., Dick, J.T.A., O'Connor, N.E., 2015. Predation in the marine intertidal amphipod *Echinogammarus marinus* leach: implications of inter- and intra-individual variation. *Journal of Experimental Marine Biology and Ecology* 462, 50-54. <https://doi.org/10.1016/j.jembe.2014.10.011>.

Almazán-Rueda, P., Schrama, J.W., Verreth, J.A.J., 2004. Behavioural responses under different feeding methods and light regimes of the African catfish (*Clarias gariepinus*) juveniles. *Aquaculture* 231, 347-359. <https://doi.org/10.1016/j.aquaculture.2003.11.016>.

Andrew, J.E., Noble, C., Kadri, S., Jewell, H., Huntingford, F.A., 2002. The effect of demand feeding on swimming speed and feeding responses in Atlantic salmon *Salmo salar* L., gilthead sea bream *Sparus aurata* L. and European sea bass *Dicentrarchus labrax* L. in sea cages. *Aquaculture Research* 33, 501-507. <https://doi.org/10.1046/j.1365-2109.2002.00740.x>.

Barbato, J.C., Daniel, P.C., 1997. Chemosensory activation of an antennular grooming behavior in the spiny lobster, *Panulirus argus*, is tuned narrowly to L-glutamate. *The Biological Bulletin* 193, 107 – 115. <https://doi.org/10.2307/1542756>.

Bardera, G., Usman, N., Owen, M., Pountney, D., Sloman, K.A., Alexander, M.E., 2018. The importance of behaviour in improving the production of shrimp in aquaculture. *Reviews in aquaculture*. <https://doi.org/0.111/raq.12282>.

Bates, D., Mächler, M., Bolker, B., Walker, S., 2014. lme4: linear mixed-effects models using Eigen and S4 (R package version 1.1-7) <http://CRAN.R-project.org/package=lme4>.

Bondad-Reantaso, M.G., Subasinghe, R.P., Josupeit, H., Cai, J., Zhou, X., 2012. The role of crustacean fisheries and aquaculture in global food security: past, present and future. *Journal of Invertebrate Pathology* 110, 158–165. <https://doi.org/10.1016/j.jip.2012.03.010>.

Bridger, D., Bonner, S.J., Briffa, M., 2015. Individual quality and personality: bolder males are less fecund in the hermit crab *Pagurus bernhardus*. *Proceeding of the Royal Society of London B: Biological Sciences* 282, 20142492. <https://doi.org/10.1098/rspb.2014.2492>.

Briffa, M., Sneddon, L.U., 2016. Proximate mechanisms of animal personality among-individual behavioural variation in animals. *Behaviour* 153, 1509–1515. <https://doi.org/10.1163/1568539X-00003402>.

Briffa, M., Weiss, A., 2010. Animal personality. *Current Biology* 20 (21), 912–914. <https://doi.org/10.1016/j.cub.2010.09.019>.

Briffa, M., Rundle, S.D., Fryer, A., 2008. Comparing the strength of behavioural plasticity and consistency across situations: animal personalities in the hermit crab *Pagurus bernhardus*.

Proceedings of the Royal Society of London B: Biological Sciences 275, 1305–1311. <https://doi.org/10.1098/rspb.2008.0025>.

Briffa, M., Sneddon, L.U., Wilson, A.J., 2015. Animal personality as a cause and consequence of contest behaviour. *Biology Letters* 11, 20141007. <https://doi.org/10.1098/rsbl.2014.1007>.

Briggs, M.R.P., Funge-Smith, S., Subasinghe, R., Phillips, M., 2004. Introduction and movement of *Penaeus vannamei* and *Penaeus stylirostris* in Asia and the Pacific. FAO RAP Publication 10, Bangkok.

Chan, S., Rankin, S.M., Keeley, L.L., 1988. Characterization of the moult stages in *Penaeus vannamei*: setogenesis and hemolymph levels of total protein, ecdysteroids, and glucose. *The Biological Bulletin* 175, 185–192. <https://doi.org/10.2307/1541558>.

Chandumpai, A., Dall, W., Smith, D.M., 1991. Lipid-class composition of organs and tissues of the tiger prawn *Penaeus esculentus* during the moulting cycle and during starvation. *Marine Biology* 108, 235 – 245. <http://doi.org/10.1007/BF00356300>.

Cleasby, I.R., Nakagawa, S., Schielzeth, H., 2015. Quantifying the predictability of behaviour: statistical approaches for the study of between-individual variation in the within-individual variance. *Methods in Ecology and Evolution* 6, 27 – 37. <http://doi.org/10.1111/2041-210X.12281>.

Comoglio, L.I., Gaxiola, G., Roque, A., Cuzon G., Amin O., 2004. The effect of starvation on refeeding, digestive enzyme activity, oxygen consumption, and ammonia excretion in juvenile white shrimp *Litopenaeus vannamei*. *Journal of Shellfish Research* 23, 243–249.

Costero, M., Meyers, S.P., 1993. Evaluation of chemoreception by *Penaeus vannamei* under experimental conditions. *The Progressive Fish-Culturist* 55, 157–162. [https://doi.org/10.1577/1548-8640\(1993\)055<0157:EOCBPV>2.3.CO;2](https://doi.org/10.1577/1548-8640(1993)055<0157:EOCBPV>2.3.CO;2).

Cuzon, G., Cahu, C., Aldrin, J.F., Messenger, J.L., Stéphan, G., Mével, M., 1980. Starvation effect on metabolism of *Penaeus japonicus*. *Proceedings of the World Mariculture Society* 11, 410–423. <https://doi.org/10.1111/j.1749-7345.1980.tb00135.x>.

Da Costa, F.P., Gomes, B.S.F., Pereira, S.D.N.A., Arruda, F.M., 2016. Influence of stocking density on the behaviour of juvenile *Litopenaeus vannamei* (Boone, 1931). *Aquaculture Research* 47, 912–924. <https://doi.org/10.1111/are.12550>.

Dall, W., 1986. Estimation of routine metabolic rate in a penaeid prawn, *Penaeus esculentus* Haswell. *The Journal of Experimental Marine Biology and Ecology* 96, 57–74. [https://doi.org/10.1016/0022-0981\(86\)90013-4](https://doi.org/10.1016/0022-0981(86)90013-4).

Dall, W., Hill, B.J., Rothlisberg, P.C., Staples, D.J., 1990. *The Biology of the Penaeidae*. *Advances in Marine Biology*. Academic Press, London.

Daniel, P.C., Shineman, M., Fischetti, M., 2001. Comparison of chemosensory activation of antennular grooming behaviour in five species of decapods. *Marine and Freshwater Research* 52, 1333-1337. <https://doi.org/10.1071/MF01013>.

- Davis, D.A., Amaya, E., Venero, J., Zelaya, O., Rouse, D.B., 2006. A case study on feed management to improving production and economic returns for the semi-intensive pond production of *Litopenaeus vannamei*. In: Cruz-Suárez, L.E., Ricque-Marie, D., Tapia-Salazar, M., Nieto-López, M.G., Villarreal-Cavazos, D.A., Puello-Cruz, A.C., García-Ortega, A. (eds.). Avances en Nutrición Acuícola VIII. VIII Simposium Internacional de Nutrición Acuícola. Universidad Autónoma de Nuevo León, Monterrey, Nuevo León, México, pp. 282–303.
- Derby, C.D., Sorensen, P.W., 2008. Neural processing, perception, and behavioural responses to natural chemical stimuli by fish and crustaceans. *Journal of Chemical Ecology* 34, 898-914. <https://doi.org/10.1007/s10886-008-9489-0>.
- Derby, C.D., Elsayed, F.H., Williams, S.A., González, C., Choe, M., Bharadwaj, A.S., Chamberlain, G.W., 2016. Krill meal enhances performance of feed pellets through concentration-dependent prolongation of consumption by Pacific white shrimp, *Litopenaeus vannamei*. *Aquaculture* 458, 13–20. <https://doi.org/10.1016/j.aquaculture.2016.02.028>.
- DeWitt, T.J., Sih, A., Wilson, D.S., 1998. Costs and limits of phenotypic plasticity. *Trends in Ecology and Evolution* 13, 77–81. [https://doi.org/10.1016/S0169-5347\(97\)01274-3](https://doi.org/10.1016/S0169-5347(97)01274-3).
- Dingemanse, N.J., Dochtermann, N.A., 2013. Quantifying individual variation in behaviour: mixed-effect modelling approaches. *Journal of Animal Ecology* 82, 39 – 54. <https://doi.org/10.1111/1365-2656.12013>.
- Dingemanse, N.J., Kazem, A.J.N., Réale, D., Wright, J., 2010. Behavioural reaction norms: animal personality meets individual plasticity. *Trends in Ecology and Evolution* 25, 81–89. <https://doi.org/10.1016/j.tree.2009.07.013>.
- FAO., 2018. The state of world fisheries and aquaculture 2018 - meeting the sustainable development goals. Rome. Licence: CC BY-NC-SA 3.0 IGO.
- Friard, O., Gamba, M., 2016. BORIS: a free, versatile open-source event-logging software for video/audio coding and live observations. *Methods in Ecology and Evolution* 7(11), 1325-1330. <https://doi.org/10.1111/2041-210X.12584>.
- Harpaz, S., Kahan, D., Galun, R., Moore, I., 1987. Responses of freshwater prawn, *Macrobrachium rosenbergii*, to chemical attractants. *Journal of Chemical Ecology* 13, 1957–1965. <https://doi.org/10.1007/BF01014678>.
- Hartati, R., Briggs, M.R.P., 1993. Effect of feeding attractants on the behaviour and performance of juvenile *Penaeus monodon* Fabricius. *Aquaculture and Fisheries Management* 24, 613–624. <https://doi.org/10.1111/j.1365-2109.1993.tb00637.x>.
- Hazlett, B.A., Bach, C.E., 2009. Individuality in the predator defense behaviour of the crab *Heterozius rotundifrons*. *Behaviour* 147, 587-597. <https://doi.org/10.1163/000579510X12629536366329>.
- Hazlett, B.A. 1995., Behavioral plasticity in crustacea: why not more? *The Journal of Experimental Marine Biology and Ecology* 193, 57–66. [https://doi.org/10.1016/0022-0981\(95\)00110-7](https://doi.org/10.1016/0022-0981(95)00110-7).

- Heales, D.S., Vance, D.J., Loneragan, N.R., 1996. Field observations of moult cycle, feeding behaviour, and diet of small juvenile tiger prawns *Penaeus semisulcatus* in the Embley River, Australia. *Marine Ecology Progress Series* 145, 43 – 51. [http://doi.org/ 10.3354/meps145043](http://doi.org/10.3354/meps145043).
- Hewes, M.E., Chaves-Campos, J. 2018., Boldness related to size in the hermit crab *Coenobita compressus* at undisturbed, but not disturbed beach. *Ethology* 124, 570 – 578. <https://doi.org/10.1111/eth.12766>.
- Holland, K.N., Borski, R.J., 1993. A palatability bioassay for determining ingestive stimuli in the marine shrimp *Penaeus vannamei*. *Aquaculture* 109, 153–164. [https://doi.org/10.1016/0044-8486\(93\)90212-H](https://doi.org/10.1016/0044-8486(93)90212-H).
- Houslay, T.M., Wilson, A.J., 2017. Avoiding the misuse of BLUP in behavioural ecology. *Behavioural Ecology* 28(4), 948 – 952. <https://doi.org/10.1093/beheco/arx023>.
- Hung, L.T., Quy, O.M., 2013. On-farm feeding and feed management in whiteleg shrimp (*Litopenaeus vannamei*) farming in Vietnam. In: Hasan, M.R., New, M.B. (eds.) *On-farm feeding and feed management in aquaculture*. FAO Fisheries and Aquaculture Technical Paper No. 583, Rome, pp. 337 – 357.
- Jory, D., Cabrera, T., 2012. Marine shrimp. In: Lucas, J.S., Southgate, P.C. (eds.) *Aquaculture: Farming Aquatic Animals and Plants*. Blackwell Publishing Ltd, Oxford, pp. 476-513.
- Lee, P.G., Meyers, S.P., 1996. Chemoattraction and feeding stimulation in crustaceans. *Aquaculture Nutrition* 2, 157–164. <https://doi.org/10.1111/j.1365-2095.1996.tb00055.x>.
- Lee, P.G., Meyers, S.P., 1997. Chemoattraction and feeding stimulation. In: D’Abramo, L.R., Conklin, D.E., Akiyama, D.M. (eds.) *Crustacean Nutrition*. World Aquaculture Society, Los Angeles, CA, pp. 292-352.
- Lima, P.P., Pontes, C.S., Arruda, M.F., 2009. Activity pattern of the marine shrimp *Litopenaeus vannamei* (Boone 1931) in laboratory as a function of different feeding frequencies. *Aquaculture Research* 41, 53–60. <https://doi.org/10.1111/j.1365-2109.2009.02302.x>.
- Martins, C.I.M., Galhardo, L., Noble, C., Damsgård, B., Spedicato, M.T., Zupa, W., Beauchaud, M., Kulczykowska, E., Massabuau, J., Carter, T., Rey-Planellas, S., Kristiansen, T., 2012. Behavioural indicators of welfare in farmed fish. *Fish Physiology and Biochemistry* 38, 17-41. <https://doi.org/10.1007/s10695-011-9518-8>.
- Nakagawa, S., Schielzeth, H. 2010. Repeatability for Gaussian and non-Gaussian data: A practical guide for biologist. *Biological Reviews* 85, 935 – 956. <https://doi.org/10.1111/1469-185X.2010.00141.x>.
- Noble, C., Kadri, S., Mitchell, D.F., Huntingford, F.A., 2007. The effect of feed regime on the growth and behaviour of 1+ Atlantic salmon post-smolts (*Salmo salar* L.) in semi-commercial sea cages. *Aquaculture Research* 38, 1686-1691.

- Nunes, A.J.P., Sá, M.V.C., Andriola-Neto, F.F., Lemos, D., 2006. Behavioural response to selected feed attractants and stimulants in Pacific white shrimp, *Litopenaeus vannamei*. *Aquaculture* 260, 244–254. <https://doi.org/10.1111/j.1365-2109.2007.01833.x>.
- Peñaflorida, V., Virtanen, E., 1996. Growth, survival and feed conversion of juvenile shrimp (*Penaeus monodon*) fed a betaine/amino acid additive. *Israeli journal of Aquaculture-Bamidgeh* 48, 3-9.
- Pontes, C.S., Arruda, M.F., 2005. Comportamento de *Litopenaeus vannamei* (Boone) (Crustacea, Decapoda, Penaeidae) em função da oferta do alimento artificial nas fases clara e escura do período de 24 horas. *Revista Brasileira de Zoologia* 22 (3), 648– 652.
- Pontes, C.S., Arruda, M.F., Menezes, A.A., Lima, P.P., 2006. Daily activity pattern of the marine shrimp *Litopenaeus vannamei* (Boone 1931) juveniles under laboratory conditions. *Aquaculture Research* 37, 1001–1006. <https://doi.org/10.1111/j.1365-2109.2006.01519.x>.
- Rosas, C., Bolongaro-Crevenna, A., Sánchez, A., Gaxiola, G., Soto, L., Escobar, E., 1995. Role of digestive gland in the energetic metabolism of *Penaeus setiferus*. *The Biological Bulletin* 189, 168 – 174. <https://doi.org/10.2307/1542467>.
- Sanchez, D.R., Fox, J.M., Lawrence, A.L., Castille, F.L., Dunsford, B. 2005. A methodology for evaluation of dietary feeding stimulants for the Pacific white shrimp, *Litopenaeus vannamei*. *Journal of the World Aquaculture Society* 36, 14–23. <https://doi.org/10.1111/j.1749-7345.2005.tb00126.x>.
- Santos, A.D.A., López-Olmeda, J.F., Sánchez-Vázquez, F.J., Fortes-Silva, R., 2016. Synchronization to light and mealtime of the circadian rhythms of self-feeding behaviour and locomotor activity of white shrimps (*Litopenaeus vannamei*). *Comparative Biochemistry and Physiology, Part A* 199, 54-61. <https://doi.org/10.1016/j.cbpa.2016.05.001>.
- Sih, A., Bell, A., Johnson, J.C., 2004. Behavioral syndromes: an ecological and evolutionary overview. *Trends in Ecology and Evolution* 19 (7), 372–378. <https://doi.org/10.1016/j.tree.2004.04.009>.
- Silva, J.F., Hamilton, S., Rocha, J.V., Borie, A., Travassos, P., Soares, R., Peixoto, S., 2019. Acoustic characterization of feeding activity of *Litopenaeus vannamei* in captivity. *Aquaculture* 501, 76-81. <https://doi.org/10.1016/j.aquaculture.2018.11.013>.
- Silva, P.F., Medeiros, M.S., Silva, H.P.A., Arruda, M.F., 2012. A study of feeding in the shrimp *Farfantepenaeus subtilis* indicates the value of species level behavioral data for optimizing culture management. *Marine and Freshwater Behaviour and Physiology* 45, 121–134. <https://doi.org/10.1080/10236244.2012.693309>.
- Smith, D.V., Tabrett, S., 2013. The use of passive acoustics to measure feed consumption by *Penaeus monodon* (giant tiger prawn) in cultured systems. *Aquacultural Engineering* 57, 38-47. <https://doi.org/10.1016/j.aquaeng.2013.06.003>.

Smith, D.M., Tabrett, S.J., Barclay, M.C., Irvin, S.J., 2005. The efficacy of ingredients included in shrimp feeds to stimulate intake. *Aquaculture Nutrition* 11, 263–272. <https://doi.org/10.1111/j.1365-2095.2005.00349.x>.

Steiner, J.E., Harpaz, S., 1987. Behavior stereotypes of food acceptance and of the rejection of 'bitter' food in the freshwater prawn *Macrobrachium rosenbergii*. *Chemical Senses* 12, 89–97. <https://doi.org/10.1093/chemse/12.1.89>.

Stoffel, M.A., Nakagawa, S., Schielzeth, H., 2017. rptR: Repeatability estimation and variance decomposition by generalized linear mixed-effect models. *Methods in Ecology and Evolution* 8 (11), 1639–1644. <https://doi.org/10.1111/2041-210X.12797>.

Stuck, K.C., Watts, S.A., Wang, S.Y., 1996. Biochemical responses during starvation and subsequent recovery in postlarval Pacific white shrimp, *Penaeus vannamei*. *Marine Biology* 125, 33–45. <https://doi.org/10.1007/BF00350758>.

Ullman, C., Rhodes, M.A., Davis, D.A., 2019. Feed management and the use of automatic feeders in the pond production of Pacific white shrimp *Litopenaeus vannamei*. *Aquaculture* 498, 44–49. <https://doi.org/10.1016/j.aquaculture.2018.08.040>.

Vega-Villasante, F., Nolasco-Soria, H., Civera-Cercedo, R., González-Valdés, R., Oliva-Suárez, M., 2000. Alternativa para la alimentación del camarón en cultivo: el manejo de la muda. In: Cruz-Suárez, L.E., Ricque-Marie, D., Tapia-Salazar, M., Olvera-Novoa, M.A., Civera-Cercedo, R. (eds.) *Avances en Nutrición Acuícola V. Memorias del V Simposium Internacional en Nutrición Acuícola*, Universidad Autónoma de Nuevo León, Mérida, Yucatán, pp. 313–320.

Wajsbrot, N., Gasith, A., Krom, M.D., Samocha, T.M., 1990. Effect of dissolved oxygen and the molt stage on the acute toxicity of ammonia to juvenile green tiger prawn *Penaeus semisulcatus*. *Environmental Toxicology and Chemistry* 9, 497–504. <https://doi.org/10.1002/etc.5620090413>.

Wight, K., Francis, L., Eldridge, D., 1990. Food aversion learning by the hermit crab *Pagurus granosimanus*. *The Biological Bulletin* 178, 205–209. <https://doi.org/10.2307/1541820>.

Wilson, D.S., 1998. Adaptive individual differences within single populations. *Philosophical Transactions of the Royal Society of London B: Biological Sciences* 353, 199–205. <https://doi.org/10.1098/rstb.1998.0202>.

Wroblewska, J., Whalley, S., Fischetti, M., Daniel, P.C., 2002. Identification of chemosensory sensilla activating antennular grooming behavior in the Caribbean spiny lobster, *Panulirus argus*. *Chemical Senses* 27, 769–778. <https://doi.org/10.1093/chemse/27.9.769>.

Zimmer-Faust, R.K., Tyre, J.E., Michel, W.C., Case, J.F., 1984. Chemical mediation of appetitive feeding in a marine decapod crustacean: the importance of suppression and synergism. *The Biological Bulletin* 167, 339–353. <https://doi.org/10.2307/1541281>.

Zuur, A.F., Ieno, E.N., Walker, N.J., Saveliev, A.A., Smith, G.M., 2009. *Mixed effects models and extensions in ecology with R*. Springer, New York.