



## Solar PV plant for supplying ancillary services in distribution systems

**Yang, Guangya; Zimmermann, Jakob Kjær; Frederiksen, Ken H. B.; Helth, Thomas; Ipsen, Hans Henrik; Hansen, Torben Vesth; Kjaer, Søren Bækthøj**

*Published in:*  
The Journal of Engineering

*Link to article, DOI:*  
[10.1049/joe.2018.9244](https://doi.org/10.1049/joe.2018.9244)

*Publication date:*  
2019

*Document Version*  
Publisher's PDF, also known as Version of record

[Link back to DTU Orbit](#)

*Citation (APA):*  
Yang, G., Zimmermann, J. K., Frederiksen, K. H. B., Helth, T., Ipsen, H. H., Hansen, T. V., & Kjaer, S. B. (2019). Solar PV plant for supplying ancillary services in distribution systems. *The Journal of Engineering*, 2019(18), 4946-4949. <https://doi.org/10.1049/joe.2018.9244>

---

### General rights

Copyright and moral rights for the publications made accessible in the public portal are retained by the authors and/or other copyright owners and it is a condition of accessing publications that users recognise and abide by the legal requirements associated with these rights.

- Users may download and print one copy of any publication from the public portal for the purpose of private study or research.
- You may not further distribute the material or use it for any profit-making activity or commercial gain
- You may freely distribute the URL identifying the publication in the public portal

If you believe that this document breaches copyright please contact us providing details, and we will remove access to the work immediately and investigate your claim.

# Solar PV plant for supplying ancillary services in distribution systems

eISSN 2051-3305

Received on 26th October 2018

Accepted on 9th January 2019

E-First on 10th July 2019

doi: 10.1049/joe.2018.9244

www.ietdl.org

Guangya Yang<sup>1</sup>, Jakob Kjaer Zimmermann<sup>1</sup> ✉, Ken H. B. Frederiksen<sup>2</sup>, Thomas Helth<sup>2</sup>, Hans Henrik Ipsen<sup>3</sup>, Torben Vesth Hansen<sup>3</sup>, Søren Bækthøj Kjaer<sup>4</sup>

<sup>1</sup>Center for Electric Power and Energy, DTU, Kgs. Lyngby, Denmark

<sup>2</sup>Kenergy ApS, Horsens, Denmark

<sup>3</sup>Bornholms Energi og Forsyning, Rønne, Denmark

<sup>4</sup>Danfoss Power Electronics, Denmark

✉ E-mail: jkzi@elektro.dtu.dk

**Abstract:** The paper reports the latest practice in the field for solar PV integration in distribution grids in Denmark, where the communication capability of solar inverters is exploited for integrating the monitoring and control functions of solar inverters into the SCADA system of the grid operator. The project demonstrates that, by implementing the enabled communication protocols of solar PV inverters in the remote terminal unit (RTU), the operator can receive measurements from the PV inverter on a variety of quantities, as well as remotely regulate the active and reactive power production for procurement of grid services. The practice demonstrates the feasibility of using solar PV plants for grid support in critical situations, where the experience is repeatable for other distribution grid operators to integrate distributed generation resources into the grid management functions. The work is carried out in cooperation with the grid operator of Bornholm, which is one of the islands in Denmark having the highest penetration of renewable energy.

## 1 Introduction

Solar PV installation is on the rise globally, driven by clean energy initiatives and quick falling of technological cost. Though the development of solar industry worldwide was halted in 2012, where many PV manufacturers either left the industry or endured an uphill battle due to steep price cuts, excess inventory, and reduced subsidies, the installation of PV capacity is still under steep increase. The globally installed capacity of solar PV is tripled from 99 GW in 2012 to 401.5 GW by the end of 2017 [1]. Recording breaking low bids for solar PV plants are seen in 2017, with some areas below USD \$ 0.03 per kWh [2]. The constant innovation in PV manufacturing and installation have contributed significantly to cost reduction.

In Denmark, though wind energy has been a primary focus area on the energy agenda, there has been a drastic increase in PV deployment in the past few years. To start with, there was only a total of 16.7 MW installed by 2011; however, the capacity increased to approximately 560 MW at the end of 2013, and till today (April 2018) reaches 924 MW. The adoption is under a rather controlled pace, powered shortly at the beginning by a subsidy scheme from the government. Later, the adoption process is driven by the decreasing cost of technology, installation and the increase of self-consumption.

The next step after PV adoption is integration. Since a large amount of solar PV can be quickly added to the distribution systems, as has been observed in many countries, many operational challenges arise for the grid operators, such as system balance and power flow management. Besides, as a generating unit, a solar PV plant is expected by the system operator to provide substantial services from PV plants to secure the entire system operation. Manufacturing standards and grid connection codes have required inverters be able to supply several ancillary services that are essential to grid operation. The grid codes in Europe and many countries in the world are all requiring services such as reactive power compensation from PV plants to support the grid voltage and/or regulate the power factor [3, 4].

The key controllable component of a solar PV plant is the PV inverter. They are capable of operating in a unit circle at any power factor, as shown in Fig. 1, where  $\theta$  is power factor angle and  $S$  is

inverter power output. The standards are usually requiring the PV to be able to reach a certain power factor regardless of the active power production level. Communication protocols accepted by solar PV inverters are being further standardised in the past few years, which can be used for remote regulation. There have been various projects studying the possibility of exploiting the converter control and communication for increasing grid host capacity of solar PV and enhance the voltage support [5, 6]. However, there is still reluctance from utilities in Denmark as well as worldwide to have large amounts of PV energy in their grids, let alone to exploit the advances of PV systems for grid operational security. This is since most PV systems have relatively smaller sizes than other power plants and their control systems are running spontaneously within the system, and the functionalities of PV inverters, though many are required by the grid operators, are still considered 'nice to have,' instead of 'essential to have.' There is still a significant barrier between technology and practice.

On this point, the Danish project PVTP [7] is set out to bring the previous learnings from a previous Danish project PVNET on the exploitation of the volt/var capabilities of solar inverters out from simulation and laboratory to the field of real applications in the island of Bornholm [8]. The main aim of the project is to provide field tests and experience of using the communication capability of solar inverters for remote monitoring and control of solar PV plant, so that the grid operators will be able to procure services from the plant of the security of operation.

## 2 Solar PV development in Bornholm

The development of solar systems in Bornholm increased significantly from 2010 to 2015, with the expansion going from less than 50 kW of solar cell capacity to 7.8 MW of installed capacity. The development was well supported based on a net measurement scheme and the 3 phases of the project Photovoltaic Island Bornholm (PVIB I-III) [9], which initially paid 25% in grants for the construction of the solar system's prize to private houses in the first place.

Bornholm has more than 1000 grid-connected solar systems and has 43% more solar power capacity per inhabitant compared to the

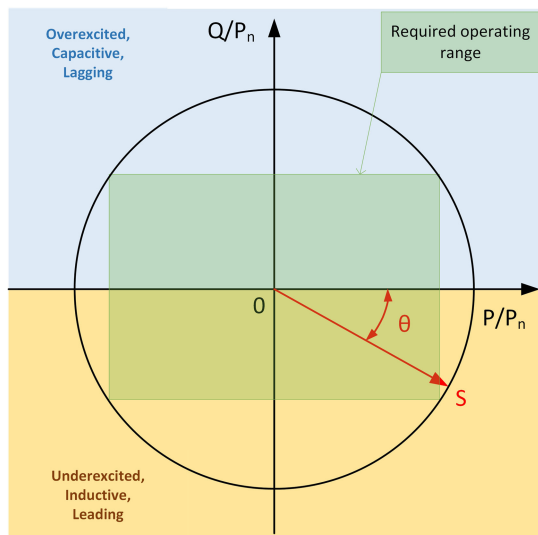

Fig. 1 Power operating range of solar PV inverter

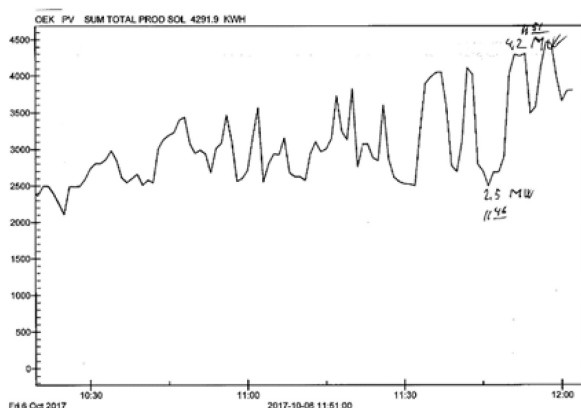

Fig. 2 Fluctuation of solar PV production in Bornholm (y-axis: kW, x-axis: time)

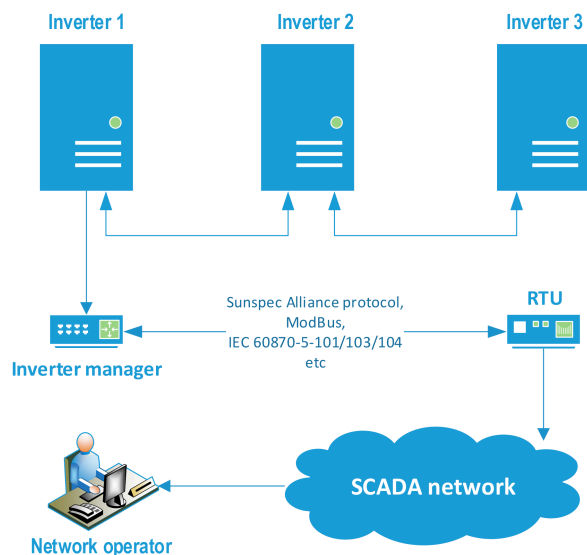

Fig. 3 Structure of the communication system

average in Denmark. The development does not stop there, because by May 2018, two additional solar parks,  $7\frac{1}{2}$  MW each, will be connected to the network. It is a Danish company called European Energy that has won a German offer for solar power plants and has chosen to place the solar plants in Bornholm. In addition to this, Bornholm County Municipality has received several inquiries regarding the possibility of placement of solar parks in the MW class.

It should be noted that the peak load of Bornholm is only 55 MW and the minimum load is at 22 MW. As there is already 37 MW installed capacity of wind, the expected solar power plant capacity of 22 MW will make it possible in sunny days to cover the power supply by renewables.

In daily operations, the island is connected to Sweden via a 60 MW 132 kV sea cable, where volatile production does not give any problem in keeping the network frequency stable. In the islanding operation, the case is different, as the island's only synchronising power plant (2 synchronous machines) itself must balance the current consumption and production. Islanding operation is scheduled every year in September, where there is service on the sea cable to Sweden, and the wind turbines may, for example, be regulated to produce low output for stable output and the older unregulated wind turbines will be stopped. The solar systems, most of them are of 6 kW, due to the regulation in Denmark, produce as the sun shines. So far, the network frequency has not been challenged, but it has definitely been noted in the control room that solar power is a highly fluctuating energy (see Fig. 2).

Therefore, there is a growing interest of the distribution grid operator (Bornholm Energi Og Forsyning, BEOF) to be able to handle an increased amount of renewable energy, especially the rise of solar energy, in the network, so that consumers are not experiencing problems at the transition to a fossil-free society. BEOF would like to gain practical experience in dealing with the distributed energy resources and possibly take advantage of these for system services. Besides the active power regulation, reactive power regulation for daily operation is also especially interesting to the operator, since all 10 kV overhead cables are wired, so over the years we have experienced an increasing need to handle voltage increases. Modern solar systems can help with that. The PVTP project addresses the growing concerns of BEOF regarding monitoring of the PV production and procurement of services for power balance and volt/var regulation.

### 3 Implementation of solar communication

The project targets at implementing an open protocol from SunSpec Alliance [10] in the industrial standard remote terminal unit (RTU), used by the distribution grid SCADA system, to achieve the communication between the RTU and the solar PV inverters, so that the grid operator in the control room can remotely poll the inverter measurements and send control signals to regulate the output of the power plant.

The plant is located at Campus Bornholm which has one of the PV plants developed in phase 3 of the PVIB project. The plant has in total 180 kW solar system composing three 60 kW inverters made by SMA. The control of the inverters is done by an inverter manager that communicates with all the three inverters forming a solar power plant. The task of the project includes both programming a SCADA RTU so that the RTU can communicate with the inverter and update the SCADA system to integrate this new RTU. Ultimately, the operator is able to monitor and control this solar power plant from the SCADA system in the control room via a fibre connection. The overall communication architecture is illustrated in Fig. 3.

The RTU communicates via Sunspec protocol with the inverter manager. The SunSpec Alliance is a trade alliance composing more than 100 solar, storage and distributed energy industrial partners, in order to pursue a common information model that can enable 'plug & play' at the distribution system for interoperability. There have been accepted by many solar inverter manufacturers. We particularly choose the plant at Campus Bornholm whose inverters are Sunspec compatible.

Getting communication between these devices to work has been a challenge despite the open protocol for the project, since the task involves RTU programming, measurement calibration, validation, etc. This shows that solutions with open protocols are not always as straightforward as expected, but when successful, it seems at least as good as proprietary solutions. Before going to the field, the project procured a Sunspec compatible single-phase inverter and tested the protocol in the lab, before the test on the actual PV plant. In the lab, the inverter is powered by a DC power source and

**Table 1** Verifying the measurements

Signal	Unit	RTU	SCADA	Inverter
freq	(Hz)	50.05	—	50.05
PF	cos $\phi$	1	1	—
va	Volt	238.1	237	—
s	VA	1400	—	—
p	W	1410	-1380	1.415
q	Var	0	0	—

**Table 2** Verifying the setpoints

Signal	Unit	RTU	SCADA	Inverter
pset = 50%	W	750	-680	750
pset = 0%	W	10	0	10
qset = -60%	var	-760	760	—
qset = 60%	var	750	-700	—
PFset = 0.8	cos $\phi$	-0.8	0.81	—
PFset = -0.8	cos $\phi$	0.799	-0.78	—

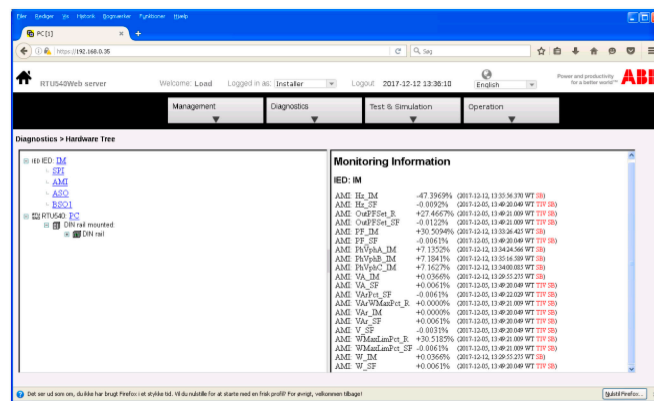
**Fig. 4** Validation of communication

connected to the lab grid. The output from the inverter is measured by the lab SCADA system. The RTU programmed for Sunspec communication is connected to the inverter. A test report was made to verify the accuracy of information received by the RTU comparing to the SCADA measurement and the inverter set points, which is given in Tables 1–2. The SCADA measurements show opposite sign on the power and power factor due to the reference direction taken. From the two tables, it can be seen that the value communicated through Sunspec reaches a good agreement with the SCADA and inverter measurements.

The validation process of the communication between RTU and the inverter manager at the Campus Bornholm is shown in Fig. 4. The measurements that can be polled from the inverter includes per phase voltage, active and reactive power, power factor, and frequency, while the parameters can be set are the maximum percentage of active power, setpoint of reactive power and the power factor.

After implementing the communication protocol of Sunspec, the SCADA system is updated in the BEOF control room so that the measurement points are integrated into the SCADA system with user interface update that enables the operator to monitor and control at the Campus' solar power plant. A screen dump of the SCADA system is shown in

Consequently, BEOF is now able to regulate active and reactive power on the plant and thus regulate the system in relation to current network conditions. It must also be possible to provide reactive power at night (Q@night function) when there is no active power from the solar power plants (usually the inverters are set in sleep mode for energy saving during the night), so that the electricity company can regulate the reactive power independent of the hours of the day. In this case, the reactive power function of the inverter is effective as a distribution system STATCOM. The entire architecture of the implementation is shown in Fig. 5.

In addition, it is necessary to investigate the effect of regulation of the plant on the local network and thus how it should be regulated in relation to this. In addition, it should be clarified whether operation and regulation of the plant have an effect on the life of inverters, transformers and cables. In practice, BEOF changed the 10/0.4 kV transformer where the solar PV plant connected to and has installed an RTU particularly for the transformer to collect data of the transformer temperature, currents and voltages, to verify the reliability of the services from the solar PV plant.

## 4 Conclusion

The paper documented the process and the field experience of implementing an open protocol for the integration of the solar PV plant in the SCADA system of the distribution grid operator. It should be mentioned that the implementation is not as straightforward as expected, and the accuracy should be verified before using for actual operation. The outcome of the project will further help the grid operator to understand the advantages and disadvantages of solar systems and may have in the local area, such that solar systems are considered not only to be a load for the grid but can also be seen as an asset if regulated in relation to the network conditions and ultimately making it cheaper to operate the mains.

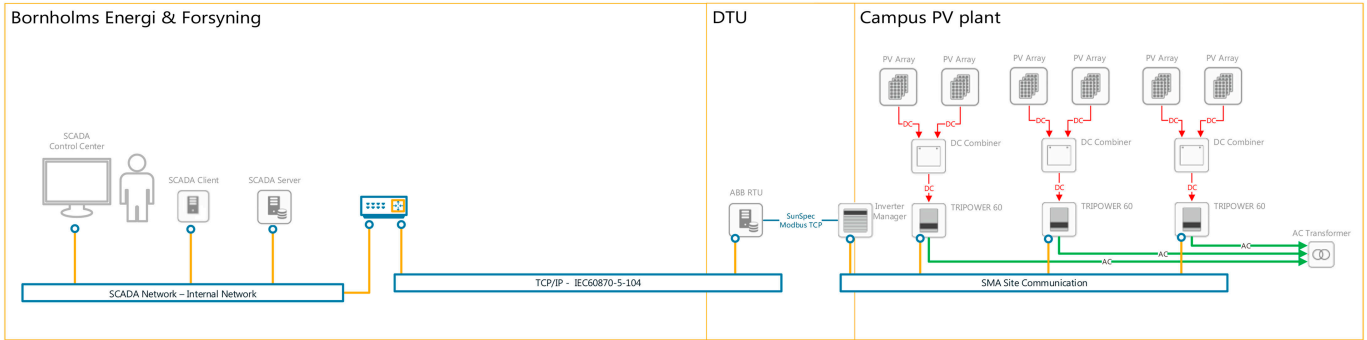

Fig. 5 Architecture of the entire system

## 5 References

- [1] CleanTechnica: 'Global solar market demand expected to reach 100 gigawatts in 2017, says SolarPower Europe', CleanTechnica, 27-Oct- 2017. [Online]. Available at <https://cleantechnica.com/2017/10/27/global-solar-market-demand-expected-reach-100-gw-2017-solarpower-europe/>, accessed 18 April 2018
- [2] REN21: 'Global Status Report', 2017. [Online]. Available at <http://www.ren21.net/status-of-renewables/global-status-report/>, accessed 2 April 2018
- [3] IEA PVPS Task 14: 'Do it locally: local voltage support by distributed generation – a management summary management summary of IEA task 14 subtask 2 – recommendations based on research and field experience', Report IEA-PVPS T14-08, 2017
- [4] EU Commission, Commission Regulation (EU) 2016/631 of 14 April 2016 establishing a network code on requirements for grid connection of generators (Text with EEA relevance), vol. 112. 2016
- [5] Juamperez, M., Yang, G., Kjaer, S.B.: 'Voltage regulation in LV grids by coordinated volt-var control strategies', *Journal of Modern Power Systems and Clean Energy*, 2014, 2, (4), pp. 319–328
- [6] YANG, G., MARRA, F., JUAMPEREZ, M., *et al.*: 'Voltage rise mitigation for solar PV integration at LV grids: studies from PVNET. dk', *Journal of Modern Power Systems and Clean Energy*, 2015, 3, (3), pp. 411–421
- [7] Danish ForskEL project: 'A live PV testing platform for larger adoption', [Online]. Available at [https://energiforskning.dk/en/projects/detail?program=28&teknologi=66&field\\_bevillingsaar\\_value=&start=2016&slut=&field\\_status\\_value=ongoing&keyword=&page=1](https://energiforskning.dk/en/projects/detail?program=28&teknologi=66&field_bevillingsaar_value=&start=2016&slut=&field_status_value=ongoing&keyword=&page=1), accessed 18 April 2018
- [8] Danish ForskEL project: 'Application of smart grid in photovoltaic power systems', PVNET.dk. [Online]. Available at <https://sites.google.com/site/pvnetdk/>, accessed 18 April 2018
- [9] 'PVIB', [Online]. Available at [https://energiforskning.dk/en/projects/detail?program=31&teknologi=All&field\\_bevillingsaar\\_value=&start=&slut=&field\\_status\\_value=done&keyword=PVI B&page=1](https://energiforskning.dk/en/projects/detail?program=31&teknologi=All&field_bevillingsaar_value=&start=&slut=&field_status_value=done&keyword=PVI B&page=1), accessed 18 April 2018
- [10] SunSpec Alliance: 'SunSpec alliance: information standards for distributed energy', SunSpec Alliance, San Jose, CA, USA, May 2014