



## Review article

Physiological feelings<sup>☆</sup>

Edward F. Pace-Schott<sup>a,\*</sup>, Marliisa C. Amole<sup>b</sup>, Tatjana Aue<sup>c</sup>, Michela Balconi<sup>d</sup>, Lauren M. Bylsma<sup>b</sup>, Hugo Critchley<sup>e</sup>, Heath A. Demaree<sup>f</sup>, Bruce H. Friedman<sup>g</sup>, Anne Elizabeth Kotynski Gooding<sup>f</sup>, Olivia Gosseries<sup>h</sup>, Tanja Jovanovic<sup>i</sup>, Lauren A.J. Kirby<sup>j</sup>, Kasia Kozłowska<sup>k</sup>, Steven Laureys<sup>h</sup>, Leroy Lowe<sup>l</sup>, Kelsey Magee<sup>f</sup>, Marie-France Marin<sup>m</sup>, Amanda R. Merner<sup>f</sup>, Jennifer L. Robinson<sup>n</sup>, Robert C. Smith<sup>o</sup>, Derek P. Spangler<sup>p</sup>, Mark Van Overveld<sup>q</sup>, Michael B. VanElzakker<sup>r</sup>

<sup>a</sup> Harvard Medical School, Boston, MA, USA

<sup>b</sup> University of Pittsburgh, Pittsburgh, PA, USA

<sup>c</sup> University of Bern, Bern, Switzerland

<sup>d</sup> Catholic University of Milan, Milan, Italy

<sup>e</sup> University of Sussex, Sussex, UK

<sup>f</sup> Case Western Reserve University, Cleveland, OH, USA

<sup>g</sup> Virginia Tech, Blacksburg, VA, USA

<sup>h</sup> University of Liege, Liege, Belgium

<sup>i</sup> Emory University, Atlanta, GA, USA

<sup>j</sup> University of Texas at Tyler, Tyler, TX, USA

<sup>k</sup> University of Sydney, Sydney, Australia

<sup>l</sup> Neuroqualia (NGO), Truro, Nova Scotia, Canada

<sup>m</sup> Université du Québec à Montréal, Montreal, Canada

<sup>n</sup> Auburn University, Auburn, AL, USA

<sup>o</sup> Michigan State University, East Lansing, MI, USA

<sup>p</sup> United States Army Research Laboratory, Aberdeen, MD, USA

<sup>q</sup> Erasmus University Rotterdam, Rotterdam, the Netherlands

<sup>r</sup> Massachusetts General Hospital, Boston, MA, USA



## ARTICLE INFO

## Keywords:

Emotion

Feelings

Interoception

Somatic markers

Emotion regulation

Autonomic nervous system

Insula

## ABSTRACT

The role of peripheral physiology in the experience of emotion has been debated since the 19th century following the seminal proposal by William James that somatic responses to stimuli determine subjective emotion. Subsequent views have integrated the forebrain's ability to initiate, represent and simulate such physiological events. Modern affective neuroscience envisions an interacting network of “bottom-up” and “top-down” signaling in which the peripheral (PNS) and central nervous systems both receive and generate the experience of emotion. “Feelings” serves as a term for the perception of these physical changes whether emanating from actual somatic events or from the brain's representation of such. “Interoception” has come to represent the brain's receipt and representation of these actual and “virtual” somatic changes that may or may not enter conscious awareness but, nonetheless, influence feelings. Such information can originate from diverse sources including endocrine, immune and gastrointestinal systems as well as the PNS. We here examine physiological feelings from diverse perspectives including current and historical theories, evolution, neuroanatomy and physiology, development, regulatory processes, pathology and linguistics.

## Introduction

Conscious emotional experience is closely bound to changes in

bodily sensations. Indeed, if one accepts the notion that consciousness is grounded in biological processes (Crick, 1994; Damasio, 1994; Pinker, 2018), emotional experience must, by its nature, be

<sup>☆</sup> Please note: Co-author listing is based on alphabetical order.

\* Corresponding author at: Harvard Medical School, Massachusetts General Hospital – East, CNY 149 13th Street Room 2605, Charlestown, MA 02129, USA.

E-mail address: [epace-schott@mgh.harvard.edu](mailto:epace-schott@mgh.harvard.edu) (E.F. Pace-Schott).

<https://doi.org/10.1016/j.neubiorev.2019.05.002>

Received 13 November 2018; Received in revised form 27 March 2019; Accepted 3 May 2019

Available online 22 May 2019

0149-7634/ © 2019 The Authors. Published by Elsevier Ltd. This is an open access article under the CC BY-NC-ND license

(<http://creativecommons.org/licenses/by-nc-nd/4.0/>).

physiological. However, the direction of causality and the specificity of relationships between physiological processes and emotional experience have been topics of debate since at least the 19th century. This review focuses on interaction between subjective emotional experience and the body. Specifically, we address how emotional feelings are informed by physiological processes that are detected by peripheral organ ‘interoceptors’, encoded and transmitted from the peripheral nervous system (PNS), to be represented at specific levels of the central nervous system (CNS). We additionally address how emotional experience may encompass the prediction, as well as feedback, of physiological changes, through efferent responses from CNS to PNS that change bodily physiology as an obligatory component of an emotive response.

This work is undertaken as part of ‘The Human Affectome Project’, an initiative organized in 2016 by a non-profit organization called Neuroqualia. The project aims to produce a series of overarching reviews that summarize current knowledge about affective neuroscience and the language that we use to convey feelings and emotions. The projects comprise twelve teams, organized into a task force with the aim of developing a comprehensive and integrated model of affect to serve as a common focal point for future affective research. To that end, our team was specifically tasked to review neuroscience research on the relationship between subjective experiences of emotion and associated physiological processes. We were also asked to review the language that people use to express feelings that relate to physiological processes and consider whether or not feelings that people convey in language might inform the way we approach neuroscience research on these topics. An important reason to focus on the physiology of emotional experience and expression along with consideration of emotional language is the well-documented imprecision inherent in self-report instruments for such experiences (Harmon-Jones et al., 2016; Mauss and Robinson, 2009). Moreover, emotion is a multi-component process hence it is important to examine from different levels, including physiology, which is complementary to self-reported experience and behavior.

A unifying theme of this review is that the subjective experience of emotion is influenced, and often determined by CNS representations of afferent sensory input from peripheral organs and tissues – conventionally termed interoception (Craig, 2016; Critchley and Garfinkel, 2017; Damasio and Carvalho, 2013). We strive to follow Damasio and Carvalho’s (Damasio and Carvalho, 2013) distinction between ‘emotion’ – an adaptive, patterned neural response akin to physiological drives such as hunger and thirst, and ‘feeling’ – internal sensations resulting from these patterned responses as well as from other interoceptive sources. However, we also acknowledge models of emotion that encompass experiential, physiological and behavioral dimensions as well as the notion of ‘construction’, in which conscious affect lies at a level below labeled emotions built from cognitive representations of context, physiology and prior experience (Barrett, 2017c). (Note that operational definitions are provided in Box 1 and nuanced distinctions are further elaborated by the Affectome Project in the “Linguistics” section of this review).

Three additional aspects of interoception are hypothesized. First, CNS representations of interoceptive information need not reach the level of conscious awareness in order to profoundly influence the subjective phenomena of feelings and emotions (Wiens, 2005). Second, the CNS efferent responses that target the sources of afferent input, as well as the resulting re-afferent feedback, can contribute to the subjective experience of emotion (Damasio and Carvalho, 2013). Third, interoceptive feelings can be both generated and perceived within the CNS (Barrett and Simmons, 2015; Damasio, 1996; Seth and Friston, 2016).

These latter two points extend the tight physiological definition of interoception beyond afferent sensory input and representation to inferential computational processes that ultimately support experience. Thus, recent models of interoception and emotion incorporate Bayesian concepts (e.g. predictive coding), wherein the brain makes sense of dynamic changes in a wealth of viscerosensory information by predicting likely causes of those changes: prior interoceptive experiences

are deployed as predictions of probable interoceptive experience, to yield ‘prediction errors’, i.e., the difference between an expected internal state and afferent interoceptive data (Barrett and Simmons, 2015; Paulus and Yu, 2012; Saxe and Houlihan, 2017; Seth and Friston, 2016). One remarkable corollary of this perspective is that, when prediction errors are small, interoceptive experience may be generated largely by what our brain expects to feel rather than by actual afferent neural signals from the periphery (Barrett and Simmons, 2015; Seth and Friston, 2016). Also the ‘top-down’ efferent neural drive to the PNS to change the internal bodily state supports ‘active inference’, whereby prediction errors are minimized by changing the input (feedback) at source. These counterintuitive possibilities capture the key function of interoception in the maintenance of physiological homeostasis (Seth and Friston, 2016). Thus, centrally-generated predictions of physiological states are expressed in autonomic reflexes. Unpredicted interoceptive inputs generate prediction errors, which trigger both emotional feelings and homeostatic responses (Seth and Friston, 2016). Although this review will not describe in detail the theoretical and computational models of predictive coding, active inference or Bayesian analyses of the physiology of emotions, it is crucial to bear in mind that the reality of perceived emotions (including their interoceptive components) encompasses more than the direct representation of peripheral states and includes central predictions of peripheral physiology.

Another important, but difficult distinction is between emotion and mood (Beedie et al., 2005). Typically these are operationally distinguished by duration and sometimes by intensity or reactivity (Beedie et al., 2005; Kaplan et al., 2016), but consensus regarding cutoffs on any dimension is lacking. This review conceptualizes emotion as a phasic response, yet recognizes its overlap with the enduring phenomenon of mood (particularly when describing interoceptive influences of tonic or gradually changing physiological state including the fluctuating hormonal milieu, pain, sickness and inflammation). Indeed, mood states are perhaps the affective phenomena most strongly influenced by interoception and are recognizably a powerful biasing factor for the subjective experience and regulation of affective feelings in both normal emotion (Ritchie et al., 2009; Sereno et al., 2015) and psychopathology (Gilbert et al., 2013).

This review will not seek to provide an exhaustive account of the physiology of emotion or the phenomenon of interoception. Instead, we highlight a sample of important theories and discoveries with an appreciation for their historical precedents and clinical relevance. The following provides a brief overview:

Reductionist ‘peripheral’ theories of emotion, asserting that physiological responses precede emotions (James, 1884; Lange, 1922), and their rebuttal by ‘central’ theories asserting central determinants of emotion specificity and nonspecific PNS responses as epiphenomena (Bard, 1928; Cannon, 1928), established a scientific dialectic that persists to this day. However, recent neuroscientific evidence describes dynamic and often flexible interactions, wherein emotions generate efferent influences on peripheral physiology from central representations (including predictive active inference) and are, in turn, shaped by afferent information from the periphery (including prediction errors). These later theories also accommodate critical contributions of cognitive appraisals and psychosocial determinants in inferential predictive representation of emotion.

The evolutionary importance of emotions and their function in intra-specific communication was articulated in Darwin’s prescient work, *The Expression of the Emotions in Man and Animals* (Darwin, 1872). Recognition of the evolutionary importance of emotions has helped drive the field of evolutionary psychology (Cosmides and Tooby, 2013).

Advances in human neuroscience have greatly informed our understanding of emotion with implications for all such emotion theories. Functional neuroimaging, particularly functional magnetic resonance imaging (fMRI), permits detailed examination of CNS representations of emotion. Moreover, meta-analytic approaches to fMRI data continue to highlight key commonalities underpinning emotional mechanisms

**Box 1**

Operational, working definitions of terms frequently used throughout this review that roughly follow those of [Damasio and Carvalho \(2013\)](#). Note that these definitions are influenced by what they seek to explain and they are not advanced as universal definitions. Additional terms are defined in relevant sections.

*Feeling*

Sensations perceived as emanating from inside the body that may originate from afferent information from peripheral receptors (including visceral, temperature and pain) that has been processed to varying degrees (e.g., in brainstem nuclei and thalamus), or that may originate from central representations of such bodily sensations in the brain itself.

*Emotion*

A programmed neural response evolved to serve an adaptive function by mobilizing specific neural activity in both the brain and periphery and by favoring certain behaviors. An emotional response can be evoked by, generate, or be shaped by specific feelings as well as by specific exteroceptive stimuli, cognitions or cognitive processes.

*Mood*

A valenced, tonic, persisting state during which valence-congruent phasic feelings may repeatedly arise or emotional responses may be evoked. Mood is distinguished from feelings and emotion by its duration whether or not it is tied to a specific stimulus.

*Affective*

Pertaining to a valenced feeling, mood or emotional response.

*Afferent*

A directional term referring to information flow, encoded as neural activity, from a more peripheral locus in the nervous system to a more central locus. For example, movement, at each step or in total, from a sensory receptor through the peripheral nervous system, spinal cord and/or brainstem nuclei and thalamus, to primary, unimodal and multimodal association cortices.

*Efferent*

A directional term referring to information flow from a more central locus in the nervous system to a more peripheral locus. For example, movement in the opposite direction along the above afferent pathway.

*Interoception*

Receipt, by the brain, of afferent sensory input from peripheral organs, tissues and physiological processes, or receipt of information from brain representations of such organs, tissues and processes by other regions of the brain. Interoception may be consciously perceived in which case it is very similar to feeling. Interoception may also affect feelings or generate peripheral physiological changes by evoking efferent signals below the level of consciousness.

*Homeostasis*

An optimum physiological state from which departures trigger automatic physiological and behavioral processes which seek to return physiological values to those of that state. Emotions have been hypothesized to have evolved, in part, to favor behaviors that promote return to homeostasis.

*Emotion processing*

Changes occurring in an emotional response once it has been evoked that may result from deliberate or automatic processes such as cognitive attributions that diminish or augment response, intrinsic physiology (e.g., activation then dissipation of stress response), active behavior (e.g., avoiding the evoking stimulus), etc.

*Emotion regulation*

A form of emotion processing, deliberate or automatic, that acts to augment or diminish the duration or intensity of an emotional response to a more manageable level. Regulation may occur before (e.g., avoidance, cognitive preparation) or during an emotional response (e.g., suppression, reattribution). Regulation may also result from low-level neural processes such as habituation and extinction.

*Emotional perception*

The degree of and nature of awareness that an emotional response has been evoked including, for example, continua from unawareness (alexithymia) to hyper-awareness, habitual biases toward one or the other end of a valence continuum.

*Emotional experience*

The subjective state when an emotional response has been evoked. May vary from unawareness to hyper-awareness of the ongoing response, or may be a transformation of response (e.g., somatization).

(Note feelings and moods can also be processed, regulated, perceived and experienced albeit by mechanisms that may differ from those directed toward an emotional response.)

across distinct studies (e.g. [Phan et al., 2002](#); [Phan et al., 2004](#); [Yarkoni et al., 2011](#)). Although fMRI provides excellent spatial resolution, it shows poor temporal resolution. Among other techniques for the study of emotion and interoception, neural recording (scalp and intracranial EEG; magnetoencephalography) using event related potentials (ERPs) provides convergent information on the millisecond scale about timing of relevant brain responses. ERPs are time domain measures which reflect changes in neural activation in response to specific stimuli. Frequency domain measures (i.e., neural oscillations at specific frequencies) can also be extracted from scalp-recorded EEG signals that may reflect important aspects of emotional processing, though thus far these have been primarily investigated in the context of response to rewarding stimuli (for review, see [Glazer et al., 2018](#)).

Modern studies of interoception as a discrete topic of neurocognitive inquiry were presaged by decades of research on the influence of the autonomic nervous system on emotion. Following influential reviews ([Cameron, 2001](#); [Craig, 2002, 2016](#); [Critchley, 2005](#)), the study of

interoception in relation to normal emotion has blossomed ([Barrett, 2017c](#); [Craig, 2010](#); [Critchley and Garfinkel, 2017](#); [Kleckner et al., 2017](#); [Krautwurst et al., 2016](#); [Strigo and Craig, 2016](#)). Three very different types of feelings clearly representative of those based on interoception – nociception, disgust and empathy – will be discussed. Abnormalities of interoception are now recognized to occupy a central role in the conceptualization of addiction and other psychiatric disorders ([Gray and Critchley, 2007](#); [Khalsa et al., 2018](#); [Paulus and Stein, 2010](#); [Paulus and Stewart, 2014](#); [Paulus et al., 2009](#)).

Peripheral systems that influence subjective feelings convey physiological information to the CNS via interoceptive mechanisms operating at both conscious and unconscious levels. This is the case both for classical stress systems in the HPA axis and sympathetic nervous system as well as other neuroendocrine systems including gonadal steroids and neuropeptides such as oxytocin. Interoceptive feelings are nowhere more apparent than in the human reward system manifesting both as “wanting” and “liking” ([Berridge and Kringelbach, 2015](#); [Paulus and](#)

Stewart, 2014). Like the endocrine system, the immune system's influence on emotional experience may result from long-latency, tonic processes, such as inflammation (Harrison et al., 2009). Another newly appreciated influence on emotion is the gastrointestinal system with its enteric nervous system and gut microbiota, where the vagus nerve is proposed as a potential pathway through which the brain and the gut may influence each other (Cryan and Dinan, 2012, 2015; Rook et al., 2014).

The ability of peripheral physiology to influence emotion below the level of conscious awareness raises the question of whether emotion can be experienced or expressed with absent or attenuated consciousness. This topic has been explored in the case of unresponsive wakefulness syndrome and the minimally conscious state. Emotion in the diminished states of consciousness during sleep and dreaming are also considered.

Regulation of emotion is inseparable from the ability to regulate physiological state. Both conscious and automatic emotion regulation is heavily reliant upon perception of interoceptive feedback. The vagus nerve represents one important conduit for afferent interoceptive information to flow from the viscera, via the brainstem, to the forebrain, as well as for efferent emotion regulatory mechanisms to influence visceral activity. Another key interoceptive afferent input to the CNS is the lamina 1 spinothalamic tract with its A-delta and C-type fibers (Craig, 2002, 2016). A key mechanism by which humans regulate emotion is the ability to tolerate, via compensatory behaviors, 'unhealthy' physiological and psychological states beyond their normative range of values (McEwen and Wingfield, 2003). Adaptive physiological regulation is put on hold to meet transient challenges. These allostatic responses within stress systems allow humans to temporarily tolerate abnormally elevated levels of physiological stress in support of concomitant emotive behaviors. However, when chronic, the emotional (e.g. anxiety) and physiological adjustments increase 'allostatic load' undermining long-term physiological and emotional health (McEwen, 1998).

Dramatic changes in the ability and strategies for emotion regulation occur across the lifespan. Notably, acquisition of basic emotion regulatory skills are among the earliest milestones in normally developing infants and toddlers. Emotion regulatory skills continue to develop into adolescence and early adulthood, paralleling brain changes, e.g. myelination of frontal projections. Interoception plays an early and sustained role in these processes, underpinning the subjective physiological experience of distress that demands regulation, and communicating the amelioration of that distress that signals successful regulation and can facilitate learning (by negative reinforcement). A social mechanism, overlooked until only recently – coherence of physiological responses in close dyadic relationships – supports emotional regulation of one or both members of the dyad, and directly facilitates emotion regulatory learning via interoceptive feedback (e.g. in a parent–infant dyad).

Human emotion regulation is aided by two primitive learning processes – extinction and habituation – that we share with nearly the entire animal kingdom. Arguably, these represent the neural foundation upon which more advanced (e.g. cognitive) processes of human emotion regulation are built (Delgado et al., 2008). These processes are accompanied by brain plasticity, and here the emotional regulatory function of sleep is gaining important recognition in affective neuroscience and psychiatry (Goldstein and Walker, 2014; Pace-Schott et al., 2015a,b; Palmer and Alfano, 2017; Tempesta et al., 2017).

In psychopathology and neuropathologic syndromes, the normal relationship between physiology and emotion is typically disrupted and accompanied by altered interoception (Khalsa et al., 2018). A particularly compelling example is somatization, in which abnormal interoception can occur at multiple points in the pathway from peripheral sense organs to central representation. In contrast, psychological experience may become uncoupled from the physiological/behavioral expression of a specific emotion in neurologic disorders such as

pseudobulbar affect. Similarly, in parasomnias, dissociation between different elements of full wakefulness sometimes allow emotional behaviors to be expressed automatically. Lastly, symptoms of neuropsychiatric disorders can reflect the interoceptive awareness of an abnormal physiological state (as in panic attack) or of a normal physiological response (e.g., grief) activated under inappropriate circumstances (e.g., major depressive episode).

Interoception plays a key role in each of the above normal and abnormal experiences of physiological emotion. The ways in which these experiences are labeled and communicated verbally can also vary dramatically among different languages and cultures. In the English language, some expressions of physiological feelings are unambiguous (hunger, thirst, pain, temperature). However some interoceptive feelings are extremely subtle, their description may rely upon metaphor or analogy (e.g., "butterflies in the stomach"), and many are difficult to map onto specific physiological events. It is likely that some of these reflect the constrained awareness and integration of bodily signals that nevertheless influence feelings, emotions and moods (Craig, 2002, 2009; Damasio and Carvalho, 2013). One goal of the Affectome Project's linguistic approach is to identify how language may reveal experiential feelings and associated physiological processes meriting further study.

## 2. Theories of emotion and physiology

When asked to define emotions, most researchers will include physiological terms. However, accounts disagree on the importance and nature of physiological changes associated with different emotions. Whether or not emotions are characterized by unique physiological changes (i.e., emotion-specific physiological response patterns) has been fervidly debated since the 19th century (e.g., James, 1884; Lange, 1922 vs. Bard, 1928; Cannon, 1928). Currently the predominant opinion is that somatovisceral and central nervous responses associated with an emotion serve to prepare situationally adaptive behavioral responses (e.g., Ohman and Mineka, 2001; Panksepp, 2000).

According to theorists endorsing the arousal concept (e.g., Duffy, 1972), emotion-specific response profiles do not exist. Instead, behavior and related psychological processes are suggested to be based on a unidimensional activation concept. Whereas it should be possible to measure psychological activation (i.e., emotional arousal) by using any single physiological variable (see, however, Duffy, 1972, for legitimate exceptions [e.g., during voluntary suppression of activity in specific muscles]), it would not be possible to draw qualitative inferences about the kind of predominating emotion. However, correlations between different psychophysiological measurements are often low or even nonexistent (see Fahrenberg and Foerster, 1982; Stemmler, 1992), thus questioning the arousal concept. Investigations of the specificity versus aspecificity of autonomic correlates of particular emotions have a rich history that is reviewed in detail in Section 5.

Other dimensionalists (e.g., Barrett, 2006; Bradley et al., 1992) do not assume fine-grained emotion-specific physiological response patterns either, but propose instead two (or three) strategic emotion dimensions (e.g., appetitive versus aversive action dispositions) that are assumed to be closely linked with physiological responses. Commonly, these emotion dimensions are related to activity in specific subcortical networks (appetitive system: e.g., nucleus accumbens, mesolimbic dopaminergic system; aversive system: e.g., amygdala; see also Davis, 1989; LeDoux, 2000). In addition, authors in this tradition admit the existence of so-called tactical aspects of emotions that consider contextual conditions during goal pursuit. Both strategic and tactical aspects of emotions would be supported by dynamic physiological response profiles well explained via the defense-cascade model (Bradley and Lang, 2007). Similar thoughts are at the basis of theoretical models proposed by Davidson (Davidson et al., 2000) and Gray (Gray and Maccagnan, 2000).

In contrast, authors in the tradition of basic emotions (e.g., Ekman,



1992a) postulate the existence of a limited number of distinct emotions that are characterized by specific (i.e., qualitatively different) central nervous and somatovisceral response profiles. Some (e.g., Levenson, 2003) admit the possibility that certain basic emotions (e.g., joy) are characterized by only low or even no physiological specificity at all, because they entail no need for immediate survival-relevant responses. Basically, emotion-specific bodily response patterns are thought to physiologically prepare the organism for specific emotion-related actions, prioritizing response mobilization. Fear, for instance, initiates preparation of a flight response, whereas anger prepares the body to fight. To date, however, there is limited evidence for emotion-specificity in physiological responses, although there remains much interest in this question and its implications (e.g., Ax, 1953; Funkenstein, 1955; Kreibig, 2010; Stemmler, 1992). Whereas – taken separately – several studies seem to yield convincing evidence for the existence of emotion specificity, an overall comparison of the results stemming from different experiments shows that these are, on the whole, inconsistent (Cacioppo et al., 1997). To overcome this lack of consistency, Stemmler's (1992) component process model of somatovisceral organization posits simultaneous influences of emotion-relevant and contextual effects on human physiology. This shifts the idea of absolute emotion specificity from basic emotions (Ax, 1953; Ekman, 1992a; Lange, 1922) to context-deviation specificity. A careful control or examination of contextual influences would thus be an indispensable requirement for the identification of emotion-specific physiological changes.

A related problem for proposed emotion specificity in physiological responses is that even when confronted with the same overall experimental situation, different individuals might engage in divergent cognitive evaluations depending on prior experience and respective goals. Different evaluations of the same situation would – according to appraisal theorists (e.g., Lazarus, 1966) – lead to distinct physiological responses and feeling states. Thus, instead of manipulating a situation with respect to particular overall target emotions, various researchers engaged in a systematic manipulation of specific appraisal outcomes and studied their effects on physiology (e.g., Aue et al., 2007; Lazarus and Alfert, 1964; Pecchinenda and Smith, 1996; Tomaka et al., 1997).

Contemporary models increasingly consider emotion-associated central nervous response patterns (see also Section 4). Historically, the limbic system was conceived as an essential component of the emotional brain (e.g., Maclean, 1952; Papez, 1937). More recently, a largely subcortical neural network with the amygdala as a key region has been suggested to play a central role in the elicitation of fear (LeDoux, 2000; Ohman and Mineka, 2001; see also Adolphs et al., 1995; LeDoux and Brown, 2017). The amygdala projects to sensory cortices and both cortical and subcortical regions, including the hippocampus, to influence perception, attention, and memory (Armony and Dolan, 2002). In addition, via its connectivity with the thalamus and brain stem, the amygdala can initiate defensive responses, even before the cortical processing of detailed sensory information about threat (LeDoux, 2002). Because phobias persist despite the explicit knowledge that a feared object is harmless, the fear module has been proposed to be “impenetrable to conscious cognitive control” (Ohman and Mineka, 2001, p. 515).

The ventromedial prefrontal cortex (vmPFC) is suggested to support emotional experience through body–brain interactions. According to the somatic marker hypothesis (Damasio, 1996), human decisions are guided by anticipation of the affective consequences of specific actions, based on prior experience. This link between actions and anticipated feeling consequences relies on the vmPFC and is encoded as somatovisceral feelings through evoked physiological responses (the ‘body loop’), and their simulated representation within the brain in somatosensory and, especially, interoceptive (insular) cortices (the “as if loop”). Once established, somatic markers may be evoked predictively to weigh outcomes of different actions, thereby biasing their choices toward the best alternative (i.e., the one with the most desirable

affective consequence). In this context, somatic markers, especially the “as if loop” are conceptually similar to interoceptive predictions (priors) envisaged by Bayesian theorists (Barrett and Simmons, 2015; Seth and Friston, 2016).

Recent Bayesian theories of emotion, including the Embodied Predictive Interoception Coding (EPIC) model (Barrett and Simmons, 2015; see also Seth, 2013; Seth and Friston, 2016) emphasize the role of cortex, notably the insula, in emotion generation. Transitional cortical architecture is invoked to support Bayesian representations and computations: pyramidal projection neurons in deep (V and VI) layers of agranular cortex (in peri-genu anterior cingulate cortex, vmPFC, anterior insula) generate predictions about physiological states (and simulations of their interoceptive corollaries). These predictions are sent, via cortico-cortical projections, to dysgranular posterior and mid-insular (primary interoceptive) cortex. Here, visceromotor simulations are compared to afferent interoceptive inputs from the thalamus within a rudimentary layer IV (absent in agranular cortices) which, in turn, generate prediction errors that are sent back to agranular cortices to refine interoceptive predictions (Barrett and Simmons, 2015). Iteration of this process allows interoceptive feelings to reflect changing physiological conditions yet, if prediction error is small, what is experienced as interoception may in fact reflect the visceromotor cortex's simulation of rather than afferent representation of the body's physiological state (Barrett and Simmons, 2015).

Cerebral asymmetry underpins theoretical proposals, including the hypothesized right lateralization of emotional processes (Schwartz et al., 1975), the valence hypothesis [left lateralization of positive emotions, right lateralization of negative emotions (Gur et al., 1994)], and the action tendency hypothesis [left lateralization of emotions associated with approach, right lateralization of emotions associated with withdrawal – in particular within prefrontal areas (Harmon-Jones and Allen, 1998)]. Meta-analysis of this topic (Wager et al., 2003), however, does not fully support any of these emotion-lateralization theories. Left-dominant activation of basal ganglia (including amygdala) during withdrawal-related negative emotions, for instance, contrasts with all theories mentioned above. What is more, the absence of reliable gender differences in cerebral lateralization of emotions needs additional consideration.

In summary, emotions are integrative phenomena that cannot be unequivocally captured by any of the above formulations, though most highlight interoceptive physiological contributions. Alternatives to the somatovisceral origin of emotional experience in the James–Lange theory typically propose central mechanisms for secondarily generating interoceptive experience. For example: (1) interoception-like experiences emanate from representations of the body in viscerosensory and somatosensory cortices via an “as-if” pathway (Damasio, 1996); (2) output of central generators of emotion (e.g., amygdala) may evoke peripheral events that are then perceived via interoception (LeDoux, 2000); or (3) cortically generated predictions of peripheral states generate subjective interoceptive experience after being compared with current afferent information from the periphery (Barrett and Simmons, 2015). The following section will consider how and why human emotion, including its interoceptive components, may have evolved.

### 3. Evolutionary considerations

According to Darwin's theory of evolution, variations in traits not aiding in perpetuation of a species will be selected against, and ultimately eliminated from the gene pool, whereas characteristics proving beneficial are likely to be passed down to subsequent generations (Darwin, 1859). Though most often considered in terms of physical traits and behaviors, Darwin's theory of evolution also applies to emotions (Darwin, 1872). Emotions serve an evolutionary purpose: their experience and expression enable adaptive reactions to survival- and reproduction-related threats and opportunities (Ekman, 1992b; Nesse, 1990; Ohman, 1986; Tooby and Cosmides, 1992). Darwin (1872)

proposed the “principle of serviceable associated habits” asserting human emotional expression originates as an evolutionarily beneficial mode of intra-species communication of intentions.

To function effectively as a means of communication, emotions must be innate and culturally universal (Darwin, 1872). Notably, the way infants express emotions is consistent with adults (Izard et al., 1980). Likewise, mannerisms used by congenitally blind individuals to express emotions like happiness and pride do not differ from those in sighted individuals, despite never visually witnessing these behaviors (Galati et al., 1997; Matsumoto and Willingham, 2009). Across cultures, people experience and understand emotions similarly, even those without connection to the modern world (Ekman, 1984, 1993; Ekman et al., 1969; Elfenbein and Ambady, 2002; Elfenbein and Ambady, 2003; Izard, 1971, 1994). Arguably these illustrations exist because emotional expression is not learned, but is rather genetically encoded by evolutionary processes.

In addition, because of a shared evolutionary history, primates' emotional expressions mirror those exhibited by humans. Specifically, facial structures of humans and chimpanzees have functional similarities suggesting the capability to create similar facial expressions (Waller et al., 2006). Indeed, during positive interactions, non-human primates exhibit a “silent bared-teeth display” (reminiscent of a human smile) and “relaxed open-mouth display” (mimicking a human laugh) (Preuschoft, 1992). Likewise, humans share expressions of embarrassment with other mammals: face touching paired with downward head movements and eye gaze (Keltner, 1995; Keltner and Anderson, 2000; Keltner and Buswell, 1997). The universality of emotional behavior and expression supports the argument that emotion developed evolutionarily.

Evolutionary behaviors are those necessary for survival of a species. Eating and mating are essential behaviors that allow a species to survive. Increased dopamine (DA) release in mesolimbic reward circuitry is associated with approach behaviors that promote survival. For example, the presence of food triggers an increase in extracellular DA in the nucleus accumbens (Hernandez and Hoebel, 1988; Yoshida et al., 1992) and this increase in DA provides a chemical reward, encouraging future eating behavior. Similarly, increased DA is associated with sexual activity (Damsma et al., 1992; Pfaus et al., 1995) and, again, the pleasurable experience of increased DA triggers reward motivation, increasing potential for the behaviors to occur again.

Importantly, however, as an animal learns which stimuli predict the availability of reward, DA release advances in time to occur when such predictive signs appear rather than at reward delivery – an adaptation that facilitates reinforcement-based learning and promotes reward motivation and appetitive behaviors (Aggarwal et al., 2012; Glimcher, 2011). Reward motivation is particularly relevant to emotion. Specifically, positive high-approach motivating emotions like desire are associated with increased DA in the mesolimbic dopaminergic reward circuit, thereby promoting desire or wanting, and activating advancement toward a particular goal (Robinson et al., 2005). Research also suggests DA is actively involved in aversive motivation like escape behavior (Faure et al., 2008; Salamone, 1992). DA in the nucleus accumbens thus modulates the neocortical and subcortical areas involved in affective processes, influencing both approach and avoidance motor activity (Salamone, 1992). This “wanting” (incentive salience) system, which relies on the mesolimbic DA circuit, is distinct from neural systems that generate pleasure (“liking”) which relies on more diffuse neural loci activated by a variety of neurotransmitters (e.g., neuropeptides) but not DA (Berridge and Robinson, 2016).

Approach and withdrawal motivating emotions are associated with evolutionarily important outcomes (Darwin, 1872; Plutchik, 1980). Fear triggers sympathetic arousal, which promotes muscle activation and subsequent escape from predators (Frijda, 1986, 2009; Frijda et al., 1989). Desire triggers approach motivation toward a desired object. Anger results in renewed efforts to keep desired objects, be they food, sexual partners, or otherwise (Plutchik, 1980). Increases in DA motivate

approach (wanting) behavior toward eating, mating, protection of self and kin and other behaviors necessary for perpetuation of the species. The pleasure (liking) associated these beneficial behaviors positively reinforces them, ensuring their reoccurrence; resulting in both wanting and liking systems being transmitted to offspring and descendants.

Emotions associated with evolutionarily important outcomes are high in motivation to approach or withdraw. Emotions high in motivation, to approach – e.g., desire and anger – or withdraw – e.g., fear – both result in narrowed cognitive breadth (Harmon-Jones et al., 2013). Narrowed breadth associated with these emotions may make goals to approach or avoid more attainable. That is, by focusing attention on the target (e.g., a desired object or escape route), the individual is less likely to be distracted by irrelevant stimuli that may prevent successful goal completion (Harmon-Jones et al., 2017). If emotion and the associated cognitive narrowing are in fact evolutionarily developed processes, they should be well integrated. When a cognitive and an emotional process are integrated, they develop the capacity to influence each other bidirectionally (Simon, 1967). Indeed, the relationship between high approach motivating desire and attention is bidirectional, such that simply narrowing one's attentional scope increases approach motivation for desirable desserts (Kotynski and Demaree, 2017).

The adaptive significance for survival and reproduction is clear for interoceptive sensations associated with desire for and fulfillment of basic drives. Afferent information from interoception undoubtedly supports these basic drives such as osmoreception for thirst or metaboreception for hunger. Similarly, interoceptive signals indicating physiological deviation (prediction error) from homeostatic limits have obvious adaptive significance (e.g., thermoregulation) (Barrett and Simmons, 2015; Seth and Friston, 2016). However, the adaptive significance, in humans, of being able to sense and form predictive models of other varieties of interoceptive signals, for example of muscle tone being increased by anger or decreased during fear (freezing), may lie in the evolution of complex social behavior. As suggested by the somatic marker hypothesis (Damasio and Carvalho, 2013; Damasio, 1996), interoceptive information may bias behavior in the direction of the most advantageous outcome; in evolutionary terms being the behavior most likely to transmit one's genetic information to subsequent generations and survive long enough to do so. Here, subtler internal signals, both predictive and afferent from the PNS, may help individuals negotiate complex social behaviors (Otten et al., 2017), for example, those within a social dominance hierarchy.

In conclusion, though Darwin's theory of evolution is frequently considered in the context of physical traits or behaviors, it also explains humans' adapted capacity for emotion (Darwin, 1872). The experience and expression of emotions are universal: similar in other mammals as well as humans of all ages across cultures. Emotion may have evolved to make evolutionarily beneficial actions like eating, mating, and protecting oneself more motivating, rewarding, and likely to occur. Emotions are therefore traits naturally selected for as they provide greater chances of perpetuation of the human species. The next section will begin consideration of CNS representations of emotional perception and expression.

## 4. Central representation of emotions

### 4.1. Neuroimaging

Representations of emotions in the CNS have been investigated using a variety of frameworks (Murphy et al., 2003). Single-system models of emotion – such as the limbic system (Maclean, 1952) and the right-hemisphere models (Adolphs et al., 1996; Borod et al., 1998, 2001; Heller and Nitschke, 1997) posit that one neurological system drives the experience and expression of all emotions. Dual-system models examine potential dissociable dichotomies such as valence or approach and withdrawal (Carver and Harmon-Jones, 2009; Davidson, 1984, 1998; Davidson et al., 1990; Feldman Barrett and Russell, 1999;

Lang et al., 1997; Posner et al., 2005; Russell, 2003; Schmidt and Schulkin, 2000). Multi-system models conceptualize emotions and their correlates as discrete (Lindquist et al., 2012). Recent advancements in functional neuroimaging have afforded the opportunity to examine the neurophysiological basis of emotions in vivo, allowing for greater delineation of the central mechanisms supporting affective processes.

Single-system models have largely been absorbed into more complex theories. For example, the limbic system hypothesis, proposed by (Maclean, 1952), holds that subcortical structures constitute one system that is responsible for the experience and expression of all emotion. In a review, Murphy et al. (2003) found almost no substantial support for this view. However, involvement of the classical components of the limbic-system in emotional processing and experiences is undeniable. Similarly, the right hemisphere hypothesis, which views the right hemisphere as more emotional in general (Adolphs et al., 1996; Borod et al., 1998, 2001; Heller and Nitschke, 1997), has received mixed support (Murphy et al., 2003). Other versions of the hypothesis are better supported, but are still inconclusive. Valence asymmetry (the right hemisphere is responsible for negative emotions and the left for positive) has also received only limited support (Lindquist et al., 2012, 2016; Murphy et al., 2003). Similarly, many failed to find support for a hemispheric dichotomy between emotion perception versus expression (Adolphs et al., 1996; Borod et al., 1998, 2001; Heller and Nitschke, 1997). Recent studies suggest that emotion may be functionally lateralized in specific structures, rather than the entire cerebrum (Beraha et al., 2012; Kober et al., 2008; Lindquist et al., 2012, 2016; Murphy et al., 2003).

Instead, some researchers advocate an approach-avoidance asymmetry model (Carver and Harmon-Jones, 2009; Carver et al., 2000; Davidson, 1998; Davidson et al., 1990; Lang et al., 1997; Schmidt and Schulkin, 2000). Murphy et al. (2003) found left-lateralization for approach emotions and bilateral symmetry for withdrawal emotions, but only in the cases of happiness and sadness and in anterior brain regions. However, individual differences exist as to whether anger is an approach or avoidance emotion (Carver and Harmon-Jones, 2009; Harmon-Jones, 2003). Thus, the approach-avoidance distinction holds for emotions such as happiness, compassion, and fear, but its limited support may be due to individual differences or varying induction procedures.

Multi-system models of emotion usually encompass basic emotions, which can be discrete or continuous. Basic emotions are cross-cultural, intuitively understood, and named across languages (Ekman, 1999). Common lists include anger, anxiety, disgust, fear, happiness, and sadness. This model has also received both support (Celeghein et al., 2017; Vytal and Hamann, 2010) and criticism, with strong, consistent evidence for specialized fear processing in the amygdala and disgust processing in the insula and globus pallidus (Murphy et al., 2003), but other emotions show mixed neural representation (for review, please see Lindquist et al., 2012). Moreover, basic emotions still vary along dimensions of valence and arousal (Posner et al., 2005). Reviews have consistently concluded that single-system models are too simple, dual-system models are too coarse, and that there may not be completely distinct neural profiles for each basic emotion (Lindquist et al., 2012, 2016, 2012; Murphy et al., 2003; Touroutoglou et al., 2015). Rather, emotions likely arise from interacting neural components, and may be differentiated by subcortical and cortical networks based on their evolutionary functions (Barrett and Satpute, 2013; Berntson et al., 2007; Citron et al., 2014; Lindquist et al., 2012, 2016; Pessoa and Adolphs, 2010).

Perhaps one of the most formidable advancements in affective neuroscience has been the leveraging of big data resources to test theories of emotion and to develop convergent evidence regarding underlying neural representations. For example, application of activation likelihood estimation (ALE), a robust meta-analytic technique that statistically tests for convergence of activation patterns in functional neuroimaging data, reveals consistent, dissociable activation of distinct

areas for happiness, sadness, anger, fear, and disgust (Vytal and Hamann, 2010). Emotion specificity was confirmed by comparing emotion categories against each other. Kirby and Robinson (2017) replicated Vytal and Hamann's (2010) work using the BrainMap database and ten times the number of studies. Although evidence of distinct networks was found for some emotions, there were also brain regions that were consistently activated across all emotions, suggesting a multi-system model (Kirby and Robinson, 2017). Their results indicated more distributed subcortical- and prefrontal-based networks also observed elsewhere (Lindquist et al., 2012, 2016). Their findings were strongly right-lateralized and had strong contributions from classical limbic structures. They also found all emotions associated with activity in the right dorsolateral prefrontal cortex, suggesting it might serve as an emotional processing hub (Eickhoff et al., 2016; Kirby and Robinson, 2017; Robinson et al., 2010). Together, these meta-analyses seem to support, in part, elements of the right hemisphere hypothesis and provide limited support for a multi-system approach.

Other meta-analytic approaches have spurred new insights into affective processing. For example, Lindquist et al. (2012) framed their investigation in terms of locationism versus constructionism. Locationism ascribes specialized functions to discrete neural areas, whereas a constructionist view sees emotion as an emergent property of existing cognitive processes. They tested the locationist view in several regions mentioned in previous reviews, finding a lack of consistency and specificity across studies. They concluded that locationism is overly reductionist, and instead favored constructionism. Kober et al. (2008) eschewed theory and opted for a data-driven approach instead. They found six functional groups related to emotion, which they declined to label. Depending on meta-analytic method, idiosyncrasies of individual studies, particularly those with high numbers of participants, could potentially bias the meta-analyses and fail to reveal the true nature of the common activation across neuroimaging studies on a particular topic. Furthermore, the utility of Kober et al.'s (2008) data-driven approach without reference to socially-accepted categories is unclear, especially in the context of clinical and other applied work regarding emotions.

It is important to note that meta-analyses of neuroimaging studies have strong limitations. First, most of the analyses rely to some degree on database infrastructure, which may represent only a fraction of neuroimaging papers (Derrfuss and Mar, 2009), may be biased toward specific psychological processes (i.e., cognition), or may not have sufficiently specific information to adequately test affective processes (e.g., unclear operational definitions; the Human Affectome Project seeks to address this issue). This becomes particularly important in the discussion of emotion because different modalities can elicit varying degrees of emotion, and to our knowledge, there is no database that accounts for the dimensionality of emotional experience (i.e., valence and arousal). Second, the variety of presentations (e.g., visual versus auditory) may have substantial effects on the neural processing streams, especially as they relate to emotion (Pessoa and Adolphs, 2010). Thus, the very strengths of meta-analytic methods (i.e., ignoring study specific features to identify convergent patterns of activations) can also be their weaknesses when applied to emotions. Toward overcoming these limitations, Müller et al. (2018) have recently developed a list of ten rules to improve the integrity and generalizability of neuroimaging meta-analyses.

Reviews and meta-analyses have treated interoception separately from studies emotion (e.g., Critchley and Harrison, 2013; Schulz, 2016) although findings of recent investigations have converged (Adolfi et al., 2017; Craig, 2010; Critchley and Garfinkel, 2017; Singer et al., 2009). One recent meta-analysis showed convergence of areas linked to interoception, emotion regulation, and social cognition in the right anterior insula and neighboring lateral frontal areas, as well as the amygdala and basal ganglia (Adolfi et al., 2017; see also Singer et al., 2009). There is some evidence showing that the insula shows a postero-anterior gradient in successive stages of interoceptive processing (Craig,



2009; Namkung et al., 2017). Notably the agranular cortices (e.g., perigenual anterior cingulate cortex, vmPFC, anterior insula) are hypothesized to generate predictions of interoceptive feelings that can, in turn, predict the physiological consequences of emotional states (Barrett and Simmons, 2015; Seth and Friston, 2016).

Big data approaches have provided, to date, the most comprehensive survey of CNS emotion representation. However, they rely heavily on the models of emotion used by researchers which may bias coding and testing of results in later meta-analyses. Additionally, procedural differences across studies abound. For example, emotion elicitation practices vary widely. They may activate any number of neural networks and cognitive processes. Until we have a large, comprehensive database with strong operational definitions, it will be difficult to conclusively understand the CNS representation of various emotions. Further compounding the issue, small brain structures such as the amygdala, can be particularly difficult to image. Choices in pre-processing steps such as spatial smoothing (Fransson et al., 2002) and motion correction (Johnstone et al., 2006) may change observed activation patterns. Inconsistency across studies could also be due to the use of different selection criteria and meta-analytic techniques, as reviewed in Kirby and Robinson (2017). In order to increase our understanding of the central representation of emotion, we need large-scale functional neuroimaging studies that encompass a variety of affective tasks.

Whereas fMRI studies provide cutting-edge spatial resolution for investigating emotion representation, they provide poor temporal resolution. Because emotions are a dynamic, unfolding process in response to triggering events, converging operations are needed to examine them more completely. Electrophysiological markers of emotion do just that: ERPs derived from encephalography (EEG) reflect neurophysiological responses immediately following triggering by an emotional stimulus. While MEG also has a similar temporal resolution to EEG and better spatial localization, it is limited in only being able to measure brain activity from sulci (and not cortical gyri), and little research focusing on MEG indices of emotion has been implemented to date. Therefore, we focus on ERP indices of emotion here.

#### 4.2. Electrophysiological and peripheral measures of emotion

Before techniques of functional neuroimaging became widely available in the 1990s, classical psychophysiology of emotion had already created an immense body of knowledge on electrophysiological and peripheral measures of emotional experience as well as overt and covert emotional expression. Such measures, including time- and frequency-domain EEG, cardiovascular indices, electrodermal responses and facial electromyography including the startle response, are described in detail in four successive volumes since 1990 of Cacioppo, Tassinary and Berntson's *Handbook of Psychophysiology* (Cacioppo et al., 2017). Especially informative have been indices that directly reflect responses of the autonomic nervous system such as skin conductance (Critchley, 2002; Dawson et al., 2007) and high frequency heart rate variability, also termed respiratory sinus arrhythmia or RSA (Balzarotti et al., 2017; Electrophysiology, 1996), as indices of sympathetic and parasympathetic activity respectively. This is consistent with the notion that RSA reflects self-regulatory ability (e.g., Thayer and Lane, 2000). While historically sympathetic and parasympathetic indices have typically been examined independently, the importance of examining the dynamic interplay between sympathetic and parasympathetic regulation (such as balance or co-activation/co-inhibition) has been highlighted more recently as important for a comprehensive understanding of autonomic regulation, as these indices are not necessarily reciprocally controlled (Berntson et al., 1991; Sunagawa et al., 1998). Of similar importance are HPA axis (cortisol) and other biochemical stress biomarkers (e.g., Strahler et al., 2017). Peripheral and electrophysiological measures are of continued importance in understanding emotional behavior and have been exceedingly successful in

combination with neuroimaging paradigms (e.g., Critchley and Harrison, 2013; Milad and Quirk, 2012). Some more recently adopted techniques for studying emotion in healthy subjects include measures of inflammation (see Section 9), genetic markers (e.g., Jonassen and Landro, 2014), diverse forms of experimental neurostimulation (e.g., Busch et al., 2013; Kuo and Nitsche, 2015) and complex emotion recognition algorithms (Mehta et al., 2018). Details of these diverse methodologies are beyond the scope of this review but well described in the above-cited and similar sources. Here we will focus on findings from EEG time-domain measures – the method most often used to examine brain responses to emotional stimuli with high temporal resolution. Frequency domain EEG measures of emotion are briefly considered but not the emerging field of EEG source localization that is also increasingly used in studies of emotion (see Pourtois et al., 2008).

##### 4.2.1. Electrophysiological indices of emotion

Event-related potentials (ERPs) are time-domain scalp-recorded brain potentials that can provide temporally precise information regarding the processing of affective stimuli through the examination of the amplitudes and latencies of ERP components (Rugg and Coles, 1995). ERPs reflect neural changes in the milliseconds range that reflect rapid processing of affective stimuli, including perception, attending and orienting responses, which are critical aspects of emotional responding (Olofsson et al., 2008). Their high temporal precision allows for a detailed examination of the time course of an emotional response, providing greater ability to disentangle key processes. Several ERP components have been identified that are particularly relevant to the processing of motivationally salient information. ERP components of emotion processing are typically elicited in experimental paradigms involving viewing of emotional pictures or faces, sometimes including emotion regulation instructions, or in tasks involving anticipation of reward or reward related feedback. While these components do not map onto discrete emotions, they reflect mechanisms underlying processing of emotional information, such as motivational value.

The late positive potential (LPP) and early posterior negativity (EPN) are two components that have been examined in the context of neural processing of visual emotional stimuli. The EPN has been identified as the first cortical ERP component reflecting the facilitated processing of emotional stimuli at the early perceptual level (Schupp et al., 2004). The EPN develops at around 150 ms and is maximal between 250 and 300 ms after picture onset. The amplitude of the EPN is most pronounced for affective stimuli of high evolutionary significance, such as erotic images or pictures of mutilations (Schupp et al., 2004). Source analysis of the EPN amplitude identified a widespread network of temporo-parieto-occipital areas implicated in visual information processing (Junghofer et al., 2001). Furthermore, a recent fMRI study using rapid visual picture presentation (Junghofer et al., 2002) revealed increased activations by emotional pictures in occipital (occipital, lingual and fusiform gyrus, cuneus, calcarine), temporal (superior, mid- and inferior-temporal gyrus), and parietal (inferior and superior parietal, angular, supramarginal gyrus, precuneus) structures. The LPP is a positive deflection of the ERP signal most apparent around 400–600 ms following an emotional stimulus that is thought to reflect motivated attention to things of emotional significance to the individual (Brown et al., 2012; Cuthbert et al., 2000; Hajcak et al., 2010). The LPP is considered to be a useful neurophysiological measure for studying emotion and emotion regulation across the life span (Hajcak et al., 2010), and it has been repeatedly shown to be enhanced (increased in magnitude) in response to emotional (relative to neutral) stimuli (Hajcak et al., 2010). The LPP is generated in occipital and parietal cortices (Sabatinelli et al., 2007), which both receive projections from the amygdala, a region critical for emotional processing. Importantly, the LPP is influenced by directed instructions to utilize specific emotion regulation strategies, such that its amplitude is reduced following emotion regulation strategies aimed at reducing an emotional response (Foti et al., 2015; Hajcak and Nieuwenhuis, 2006).



Several ERP indices associated with reward anticipation and receipt have also been identified. The feedback negativity (FN) is a negative deflection of the ERP signal that peaks around 250 ms following the receipt of feedback or reward. The FN is considered to be an index of the function of a performance monitoring/evaluative system that rapidly assesses the motivational salience of positive and negative environmental feedback (Bress et al., 2013; Bress et al., 2012). The FN is thought to relate to flexible selection of actions aimed at pursuing rewards and is part of a reinforcement learning system used to adjust subsequent behavior (Bress et al., 2012). The FN is correlated with measures of reward sensitivity and is thought to reflect a binary evaluation of feedback as unfavorable or favorable (loss vs. gains) (Hajcak et al., 2007; Holroyd et al., 2003). Neuroimaging and source localization studies have shown that the FN is generated primarily by the anterior cingulate cortex, an important hub for integrating cognitive and affective processing that is also involved in emotion regulation and flexible responding (Foti et al., 2015). Concurrent ERP and fMRI studies have demonstrated that the FN amplitude is also associated with activity in the ventral striatum (Foti et al., 2011), another key area for reward processing (Liu et al., 2011).

The cue-P3 and the contingent negative variation (CNV) have been associated with aspects of reward anticipation (Goldstein et al., 2006; Pfabigan et al., 2014), where the cue-P3 reflects aspects of salience and attention during the reward anticipation process, and the CNV reflects more aspects of cognitive effort involved in the anticipation process. In the context of a reward task, the cue-P3 is a centroparietal positivity which emerges between 300 and 600 ms after an anticipation cue and its amplitude increases as a function of reinforcer magnitude (Broyd et al., 2012; Goldstein et al., 2006). The cue-P3 has been associated with neural activity in reward related regions, including the ventral striatum (Pfabigan et al., 2014), and is thought to reflect variation in context updating in working memory, such as updating whether a potential gain or loss is at stake in a monetary guessing task (Bonala and Jansen, 2012). The CNV is a negative-going potential shift that is primarily associated with anticipatory attention and preparation of effortful processes (Falkenstein et al., 2003; Gomez et al., 2007) and has been assumed to reflect neural activity within the thalamo-cortico-striatal network (Fan et al., 2007; Macar and Vidal, 2003).

Frequency based measures of EEG activity have not been used as extensively to study emotional responses, but there has been increasing interest in the utility of these measures, particularly in the area of emotional responses to rewarding stimuli (see Glazer et al., 2018 for review). For example, measures of alpha, beta, delta, or gamma neural oscillations in response to rewarding stimuli may provide complementary information to what ERP components such as the FN may provide. These oscillatory changes in the EEG signal in response to affective stimuli are also referred to as event related spectral perturbations (Makeig et al., 2004). Alpha de-synchronization in response to affective pictures has also been related to the LPP and is thought to provide complementary information about sustained attention to emotionally salient stimuli (for review, see Uusberg et al., 2013).

In studies of interoception, it is possible to measure experimentally-induced ERPs to stimuli targeting distinct organ systems (e.g., respiratory evoked potentials). However, ERP studies of interoceptive sensations have focused on the ‘natural’ heartbeat evoked potential (HEP), a positive potential occurring maximally in frontocentral derivations 250–350 ms following the R-wave in the ECG (Pollatos and Schandry, 2004). The HEP probably reflects afferent signals originating in vascular sensors (e.g., baroreceptors) transmitted rostrally via the vagus and glossopharyngeal nerves and processed in the insular and anterior cingulate cortices. The amplitude of the HEP is significantly greater in those who can more accurately detect their own heartbeat (Pollatos and Schandry, 2004). To the extent that changes in emotion reflect increased arousal, the HEP may index emotional state (Luft and Bhattacharya, 2015). Additionally, as is the case for accuracy of interoceptive heartbeat detection (Herbert et al., 2007; Pollatos et al., 2007),

the HEP may be related to state and trait measures of emotion (Fukushima et al., 2011). Interoceptive information, arrives at the cortex via spinal Lamina 1 fibers (Craig, 2016) or afferent components of the vagus nerve (Berthoud and Neuhuber, 2000) both of which are weakly myelinated and hence conduct relatively slowly. Could such interoceptive afferents influence ERPs that can occur within 150 ms of a perceived exteroceptive stimulus? Although HEPs occur within 250–350 ms of the R-wave (Pollatos and Schandry, 2004), it is possible that interoceptive effects on more rapid response potentials, such as the auditory N1 (at 140–170 ms), may result from predictions of physiological states that originate within the CNS itself (Babo-Rebelo et al., 2016; van Elk et al., 2014).

The following section will address interoception in greater detail along with discussion of three emotion-related subjective experiences, the first two of which, pain and disgust, are defined by their interoceptive features and the third of which, empathy, may be a human capacity uniquely dependent on interoception. First, however, the important linkages between the autonomic nervous system, interoception and emotion must be considered.

## 5. Autonomic nervous system and emotion

In the last century, influential theories have emphasized the role of the autonomic nervous system (ANS) in emotion. Bodily manifestations are often central to the experience of emotion, such as feeling a strong heartbeat when fearful. The bodily aspects of emotion are largely mediated by the ANS, a collection of nerve cells/fibers projecting from the spinal cord to the viscera (e.g., organs, glands, blood vessels, airways). The correlation between emotion and autonomic activity is believed to have an evolutionary function (Darwin, 1872). By distributing metabolic and other physiological resources, autonomic changes in visceral activity support emotional behaviors with survival value (e.g., approach reward, avoid threat; Levenson, 2003; Tomkins, 1962). ANS activity also influences sensory-perceptual processes that drive the experience of emotion (Craig, 2003a; Damasio and Carvalho, 2013; James, 1884). The diverse actions of the ANS are achieved by its complex organization wherein each ANS branch has afferent fibers that carry visceral information to the brain (bottom-up) and efferent fibers that regulate the viscera based on brain activity (top-down). This construction allows for feedback loops that are critical to homeostasis, stress, and emotional experience (Benarroch, 1993; Chwalisz et al., 1988). Despite its complexity and debated place in emotion theories (Friedman and Thayer, 2018), the role of the ANS in emotion can be summarized with two themes: specificity and causation.

### 5.1. Specificity

If the ANS supports behaviors unique to a specific emotion, then emotions should differ in their characteristic patterning of ANS activity. This notion of *autonomic specificity* has been widely debated in the dominant theories of emotion. Adding further complexity to the matter, views on the autonomic specificity of emotions also raise the related issue of the causal relationship between emotional experience and ANS function.

William James (James, 1884) and Carl Lange (Lange, 1885/1912; Lange, /, 1912; Lange, 1885/1912) were the first to formulate that emotions have differentiable ANS patterns. This model, that came to be known as the “James–Lange” theory of emotion, has scaffolded decades of research on basic emotions. Here, motivationally relevant stimuli first elicit autonomic and bodily changes, which then lead to emotional experience. For physiology to elicit specific feelings, emotions should have unique patterns of ANS responses. Biologically-oriented theories of emotion embrace autonomic specificity because reliable activation of pre-programmed physiological patterns is efficient and conducive to survival (Ekman, 1992b; Levenson, 2003; Tooby and Cosmides, 1990). The notion that basic emotions have some degree of autonomic

specificity is supported by rich experimental work (for review, see Kreibig, 2010) and multi-measure studies using statistical classification (Christie and Friedman, 2004; Kragel and Labar, 2013; Stephens et al., 2010).

A case has also been made for a lack of autonomic specificity (Barrett, 2006). This concept is not new, however. Cannon (1927) directly challenged James by stating that emotional feelings and ANS responses are independent, and that autonomic responses are diffuse, rather than patterned. Later, influential cognitive theories of emotion de-emphasized the centrality of autonomic function in favor of top-down appraisals (Ellsworth, 2013; Quigley and Barrett, 2014). For example, the two-factor theory emphasizes global autonomic “arousal” that leads to experience through the filter of socially constructed appraisals (Schachter and Singer, 1962).

Cognitive theories and their evidence do not hold a monolithic view of ANS specificity. Across the last four decades, studies have shown that appraisals of stressors can lead to differentiable patterns of ANS activity (Scherer, 1984). Of note, appraisal-generated patterns of ANS activity appear broader than those of the discrete emotions suggested by James (1884) and others (e.g., Ekman, 1992b). These diverse findings inspire the question: does ANS activity map onto discrete categories or onto broader dimensions related to appraisals and motivational significance? Studies in the past few decades support a role for both, implying a gradient of autonomic specificity where autonomic differentiation exists at multiple levels (e.g., Christie and Friedman, 2004; Nyklíček et al., 1997; Witvliet and Vrana, 1995). Obfuscating the matter, the degree of ANS specificity appears subject to contextual factors, individual differences, and the method of emotion elicitation (Cacioppo et al., 2000; Stemmler, 2003). Taken together, the ANS specificity of emotion conceivably exists on a continuum with the degree of specificity being determined by a constellation of neuropsychological and environmental variables that change over time. Such complexity in the coordination between ANS physiology and emotional state is possible and quantifiable in a dynamical systems model of emotion (Lewis, 2005; Thayer and Friedman, 1997). Here, the ANS rapidly “explores” many affective states in the state-space, and strong attractors (i.e., basic emotions) can pull the organism into a more programmed ANS pattern if multiple conditions are satisfied.

## 5.2. Causation

Does the ANS cause emotional experience in a bottom-up fashion, or are autonomic responses generated by top-down factors, such as affective experience and/or brain activity? Understanding the causal connections between these components is critical for a precise definition of emotion. For James and his successors in discrete emotion theory, specific physiological patterns cause emotional experience through autonomic afference to the brain (Friedman, 2010). These afferent pathways have empirical support, such that autonomic afference from the viscera influences perceptual activity in the brain (Damasio et al., 2000; Park et al., 2014). Afferent influences on emotional experience likely occur both inside and outside conscious awareness (Vuilleumier, 2005).

Cognitive appraisal models of emotion adopt a view opposite of the bottom-up perspective: cognitions about motivationally salient events cause ANS responses in a top-down manner (Blascovich and Tomaka, 1996; Lazarus and Folkman, 1984). The evidence used to support the top-down view is vast but mostly correlational. Experimental designs are rarely employed to substantiate that cognition causes emotion-related ANS responses. The top-down view nevertheless remains strong in cognitive neuroscience where the expression and regulation of emotion is putatively grounded in the frontal lobe regulation of subcortical emotion regions, including autonomic source nuclei (Roy et al., 2012; Wager et al., 2009). As with autonomic specificity, an “either-or” approach to reconciling the bottom-up vs. top-down issue is too simplistic. Functional models of central-autonomic relationships have emphasized

both autonomic afference and efference as well as their dynamic interplay in emotion (Craig, 2002; Damasio, 1994; Thayer and Lane, 2000). Direct empirical evidence for afferent–efferent interaction is surprisingly sparse, however. Neuroimaging findings revealing relations between brain activity and ANS responses during emotion are often interpreted in terms of the brain causing autonomic responses – although the direction of causation here is suggestive due to correlational designs (Macefield et al., 2013; Roy et al., 2012; Thayer et al., 2012).

Empirical support for the afferent determination of emotion may be lacking because this question is one of cause-and-effect, ultimately requiring the tight controls afforded by experimentation. While it is clear that top-down factors and the ANS interact in emotion, the dynamics of such interactions are relatively unknown. To this end, sophisticated mathematical approaches can prove useful in unraveling the complex nonlinear dynamics that characterize brain–body relationships (Lewis, 2005; Thayer and Lane, 2000). Leveraging modeling approaches with experimental techniques (e.g., pharmacological blockade and lesions) might clarify the causal role of ANS responses in emotion.

## 6. Interoception

### 6.1. Interoceptive systems

To recap, interoception describes the body-to-brain afferent signaling, central processing, and neural and mental representation of internal bodily changes. Interoception thus encompasses information concerning the dynamic functions of visceral organs, humoral cells, nutrients, hormonal messengers and signals of health and disease. Recent advances in understanding of interoceptive mechanisms include clearer anatomical description of peripheral and cerebral pathways from different bodily organs) and distinct (neural and psychological) levels of interoceptive representation and control.

Salient and emotive perceptions and cognitions elicit changes in bodily physiology which, through interoception, are encoded into affective feelings (Tsakiris and Critchley, 2016). The expression of emotion encompasses both organ-specific and general system-level changes in internal physiology, evoked most rapidly by efferent neural signals, notably autonomic responses that characteristically occur independently of volitional control. Autonomic responses and the interoceptive feedback typically guide mundane homeostatic reflexes, yet when faced with emotional challenge this vegetative control is suspended in support of response-related bodily states (for example, action-readiness when faced with the motivational immediacy of mortal threat). The accompanying motivational brain states and the interoceptive feedback of these short-term ‘allostatic’ responses contribute to the affective and emotional experience.

Physiological patterning of bodily change is suggested by the consistency with which people refer to particular internal bodily sensations when describing their emotional experiences (Nummenmaa et al., 2014). Consensus within cultures reinforce such categorical association, enabling a shared understanding of emotional categories. Nevertheless, even within an individual, interoceptive feelings (e.g. brief bradycardia) can be ascribed to very distinct emotions (heart stopping with fright or skipping with love). While interoceptive contributions to emotion are widely appreciated, controversy remains as to the degree to which interoceptive information can be emotion-specific, or even if specific emotions exist (Barrett, 2017b).

Interoception by definition originates from within the body, and not the environment: it is distinct from proprioception (information about bodily position) and from touch, taste, smell, sight and hearing (sampling the environment). Nevertheless, interoception is a broad term that refers to distinct and specific types of information originating from distinct sensor-types (e.g. stretch receptors in hollow organs, chemoreceptors in brain and nerve endings) conveyed through different afferent channels (humoral, neural, spinal, cranial nerve). These afferent

pathways interact with each other, and with exteroceptive information, at multiple levels of the neuraxis where efferent autonomic and/or hormonal/humoral responses may also be triggered hierarchically (Critchley and Harrison, 2013). Broader definitions also exist (Craig, 2016), which view interoception as a general integrated perception of bodily sensations ('intero-perception'), and resemble earlier concepts e.g. coenesthesia (Ceunen et al., 2016; Mehling, 2016). The physiological/homeostatic nature of information is perhaps part of the definition and much of this ascends in the Lamina 1 spinothalamic tract (Craig, 2016). This spinal tract also carries unmyelinated tickle, pain and temperature fibers from the skin; an organization that is used to support the notion that these motivationally-important bodily signals are also interoceptive.

The central representation, and ultimately the perceptual characteristics of interoceptive information, reflect the specific afferent pathway and the strength of the afferent signal. Interoceptive sensations are typically more general and diffuse than somatomotor and somatosensory (including most pain) sensations that are more precisely localizable. Interoceptive information may also parallel, merge with, or be overshadowed by exteroceptive sensations, e.g. the somatosensory and proprioceptive feelings of air-flow and chest expansion when breathing. Similarly, intense interoceptive signals may hijack exteroceptive pathways to dominate conscious representation, e.g., the referred pain of cardiac ischemia that is felt on the chest, neck and shoulder (Garfinkel et al., 2016a). Integrative crosstalk between afferent streams of interoceptive information begins with peripheral autonomic ganglia and continues within spinal cord into the brain. Interoceptive information is projected through medullary relays (nucleus of solitary tract), pontine hubs (parabrachial nucleus), thalamus (posteroventromedial nucleus) into representations within insular cortex (Craig, 2002). Throughout, ascending interoceptive signals share regional neural substrates and interact with descending signals that drive autonomic and humoral responses.

Notably, however, interoceptive pathways originating in peripheral autonomic ganglia, and traversing spinal cord, brainstem and thalamus to form representations in the insula (Craig, 2002) are only one of many interoceptive pathways within the highly complex neural connections that support extensive brain-body interactions. For example, in the brainstem, interoceptive afferents couple with ascending monoaminergic systems whose broad projections underpin thalamocortical arousal, attentional filtering and salience processing. There are parallel subcortical (caudate, amygdala) and cingulate projections, where neural information about bodily physiology can also shape behavior, cognition and emotion (Critchley and Harrison, 2013). Hierarchical representations with both upward and downward information flow builds an architecture for the predictive representation of the internal state of the body, which provides a powerful account of emotional control, and dynamical self-representation ('material me') which itself may underpin the continuity of conscious experience (Barrett and Simmons, 2015; Seth, 2013; Seth and Friston, 2016). However, organ-specific information is also retained, with signal-selective representations that are present in insular cortex and associated 'interoceptive' cortices (Critchley and Harrison, 2013).

From Aristotle to James and Lange, peripheral emotion theories propose that emotional behaviors and feelings are derived from internal (visceral) sensations. Logically, people who are more sensitive to interoceptive signals may experience stronger emotions or better emotional control. Individual differences in interoception have been quantified using questionnaires, and behavioral tests that either exploit natural fluctuations in internal physiological signals, or that manipulate organ physiology experimentally (Garfinkel et al., 2016a). Heartbeat detection tasks have dominated objective attempts to quantify individual differences in interoceptive ability. These typically test an individual's ability to perceive their own heartbeats at rest, indicated by counting, tapping or by judging heartbeat timing relative to an external stimulus. The psychometric limitations of heartbeat detection tasks are

widely appreciated (Brener and Ring, 2016). However, with necessary caution, data from these methods show strong predictive validity, and have helped understand how interoception contributes to normal and abnormal emotion (Critchley and Garfinkel, 2017). Recent systematic refinements distinguish between (objective) task performance, (subjective) report of, or confidence in interoceptive experience, and their (metacognitive insight) correspondence (Garfinkel and Critchley, 2013). This operational framework for evaluating psychological access to interoceptive sensations has been empirically validated and extended to encompass earlier (precognitive) measures of individual differences (e.g. influences of cardiac signals on threat processing) and higher-order switching between interoceptive and exteroceptive representations (Critchley and Garfinkel, 2017).

The impact of interoceptive signals on emotional processes is best-illustrated with respect to cardiovascular arousal, which is signaled by the firing of arterial baroreceptors in the aorta and carotids with each ventricular contraction of the heart. The timing and strength of each heartbeat is conveyed from baroreceptor to brainstem via vagus and glossopharyngeal nerves and inform the reflexive control of blood pressure through the baroreflex. Cardiovascular arousal occurs through 'top-down' baroreflex suppression, allowing heart rate and blood pressure to rise together. The impact of this cardiac interoceptive channel on perceptual aspects of emotion can be tested by comparing responses to brief stimuli presented around systole, when the baroreceptors are active, to stimuli presented at diastole, when the baroreceptors are quiescent. Generally, the heart signals inhibit sensory processing such as pain or startle responses (e.g. Schulz et al., 2016). However, these cardiac arousal signals selectively amplify the processing of threat, including the detection and perception of fear signals in others (Garfinkel and Critchley, 2016; Garfinkel et al., 2014).

Other interoceptive axes are of course relevant to affect and emotion. Glucose sensing, responses to inflammation and infection (e.g. Harrison, 2017), respiratory sensations (e.g. dyspneic load, hypoxia, hypercapnia), and gastrointestinal signals (microbiota, distention and gastric motility (Mayer, 2011) have different levels of access to conscious perception but each can shape affective feelings, motivational behaviors and emotional reactivity. Gastric interoception, tested with a waterload test (van Dyck et al., 2016), carries emotion-relevant (as well as food-relevant information) and even resting electrogastric rhythms influence activity across affective cortices (Rebollo et al., 2018). Autonomic responses in themselves are not always directly linked to interoception; sweat gland control through electrodermal activity reflecting sudomotor nerves does not have reciprocal parallel afferents. Arguably, feelings of arousal corresponding to electrodermal fluctuation are not classically interoceptive. Across organ systems, there is weak correspondence between behavioral tests of cardiac and respiratory interoceptive accuracy, and training sensitivity in one axis may not improve another (Garfinkel et al., 2016b). For example, meditative practice generally has little impact on cardiac interoceptive performance (although see Bornemann and Singer, 2017 with relevance to emotion regulation).

Overall interoception provides a route through which the physiological state, integrity and physical health of the body constrains the repertoire of emotions and motivational behaviors that an individual might experience. Moreover, body reactions to affective challenges through feedback, guide and intensify emotional feelings to add salient reinforcement to the emotional experience. The notion of interoception as a body-to-brain phenomenon is increasingly conceptualized within a predictive coding (Bayesian) framework wherein higher order expectations and beliefs concerning physiological state interact with afferent signals to shape experience, guide behavior and control the internal state. These mechanisms are important for understanding normal and abnormal emotions.

Fig. 1 depicts, in schematic form, some of the roles of interoception in neural, cognitive and physiological processes involved in the initiation and modulation of emotional responses. Fig. 2 depicts some of the

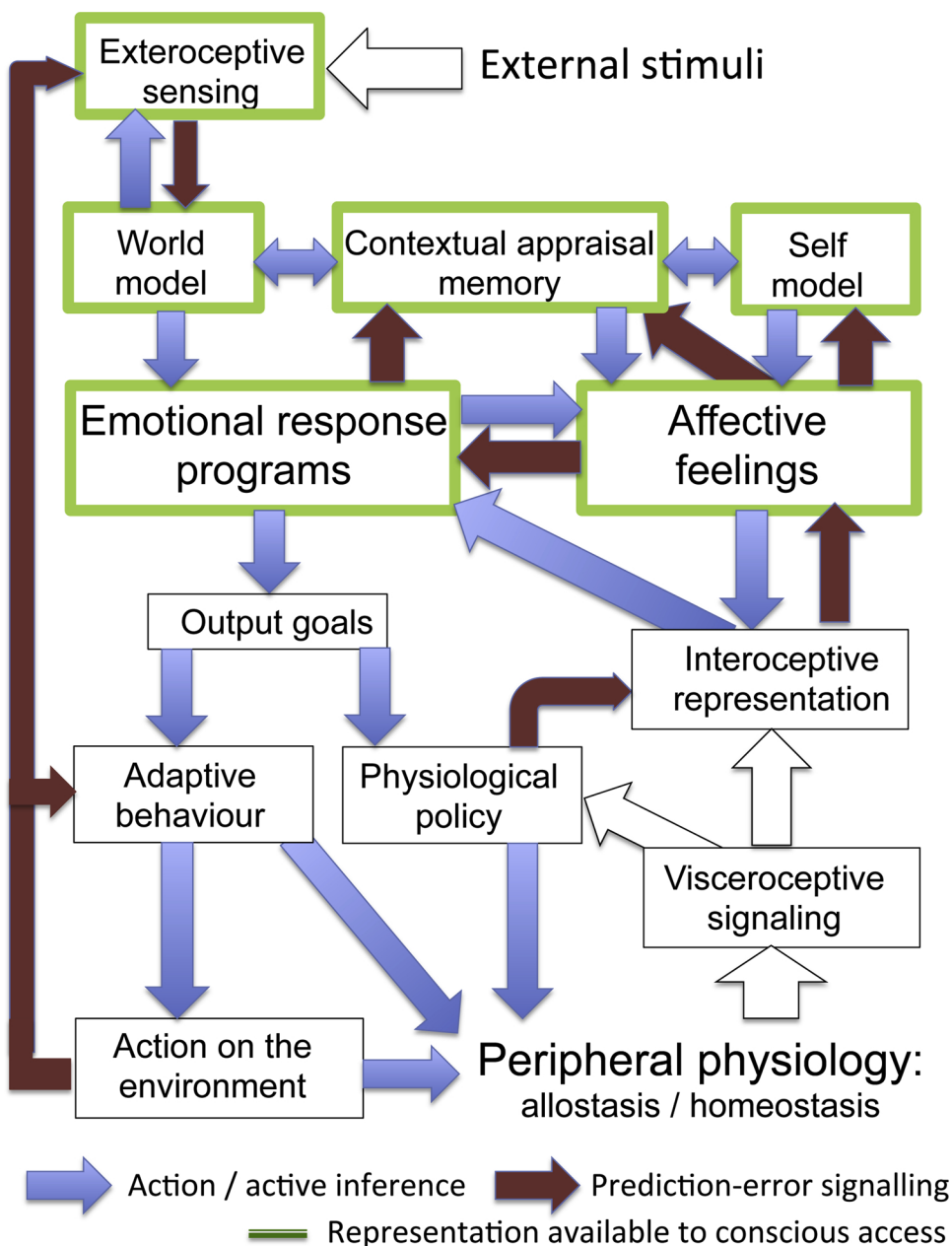

**Fig. 1.** Input and output of emotional response programs and relation to affective feelings and conscious access. Input from exteroceptive stimuli updates a representation of the external environment (“world model”) through cognitive appraisal (e.g., expectation, context and memory) to trigger emotional response programs. Affective feeling states are an important further determinant and trigger of emotional response programs. These feelings arise from integrative representation of (conscious and unconscious) afferent interoceptive information of the internal physiological state of the body, in relation to “top-down” predictive models of the self. The outputs of emotional response programs are adaptive behaviors and internal changes in bodily state that serve to support such behavior (allostasis; temporarily changing physiological set-points to surpass homeostatic boundaries). Viscerosensory (interoceptive) feedback is judged against homeostatic set-points to drive affective feelings states and regulation of allostasis/homeostatic balance. Prediction errors in interoceptive signaling thus extends closed-loop homeostatic reflex control to modify emotional response programs to better accomplish output goals and underpin affective feelings states. Based upon Barrett and Simmons (2015), Craig (2002), Critchley and Harrison (2013), Damasio and Carvalho (2013).

anatomical pathways by which autonomic and other CNS efferents influence peripheral physiology and are, in turn, influenced by afferent information from the periphery. In both Figs. 1 and 2, the putative influence of top-down predictive mechanisms is indicated.

6.2. Interoception and pain

Adopting the more inclusive definition above (Craig, 2016), pain, particularly pain of internal origin, can be classified as a form of interoception (or ‘intero-perception’). Pain is both a sensation and a feeling (Strigo and Craig, 2016) and this duality is reflected in its neurobiology. Acute pain – a time-limited activation of the nociceptive pathways – signals injury to the body and motivates protective action. Chronic pain – ongoing activation of nociceptive pathways – involves maladaptive functional and structural changes at multiple anatomical levels, and complex interactions with and modulation by endocrine, autonomic, and immune/inflammatory systems, and attentional and emotion-processing regions in the brain.

At the epigenetic level, there is evidence that changes in DNA

methylation, histone acetylation and methylation, and miRNA expression – resulting in changes in gene expression and neural function – contribute to sensitization of pain pathways (Descalzi et al., 2015; Ligon et al., 2016). At the physiological level, nociceptor activation is maintained by ongoing crosstalk between the HPA axis, the sympathetic nervous system and the immune/inflammatory systems. Activation of these systems – and concurrent down-regulation of restorative parasympathetic systems – facilitates a body-wide shift into a defensive, pro-sympathetic, pro-inflammatory, pro-pain mode (Janig and Habler, 2000; Ji et al., 2016; Leung et al., 2016; Milligan and Watkins, 2009; Schlereth and Birklein, 2008). In this defensive mode, immune/inflammatory cells situated in proximity to peripheral nociceptors and within the central nervous system (e.g., spinal level), produce pro-inflammatory neuroactive signaling molecules, which activate nociceptors and facilitate neuroplastic changes in pain pathways (peripheral and central sensitization) (Kuner and Flor, 2017).

At the spinal level, there is mounting evidence for both functional and structural plasticity changes in chronic pain (Kuner and Flor, 2017). At the brain level, there is evidence that neural networks



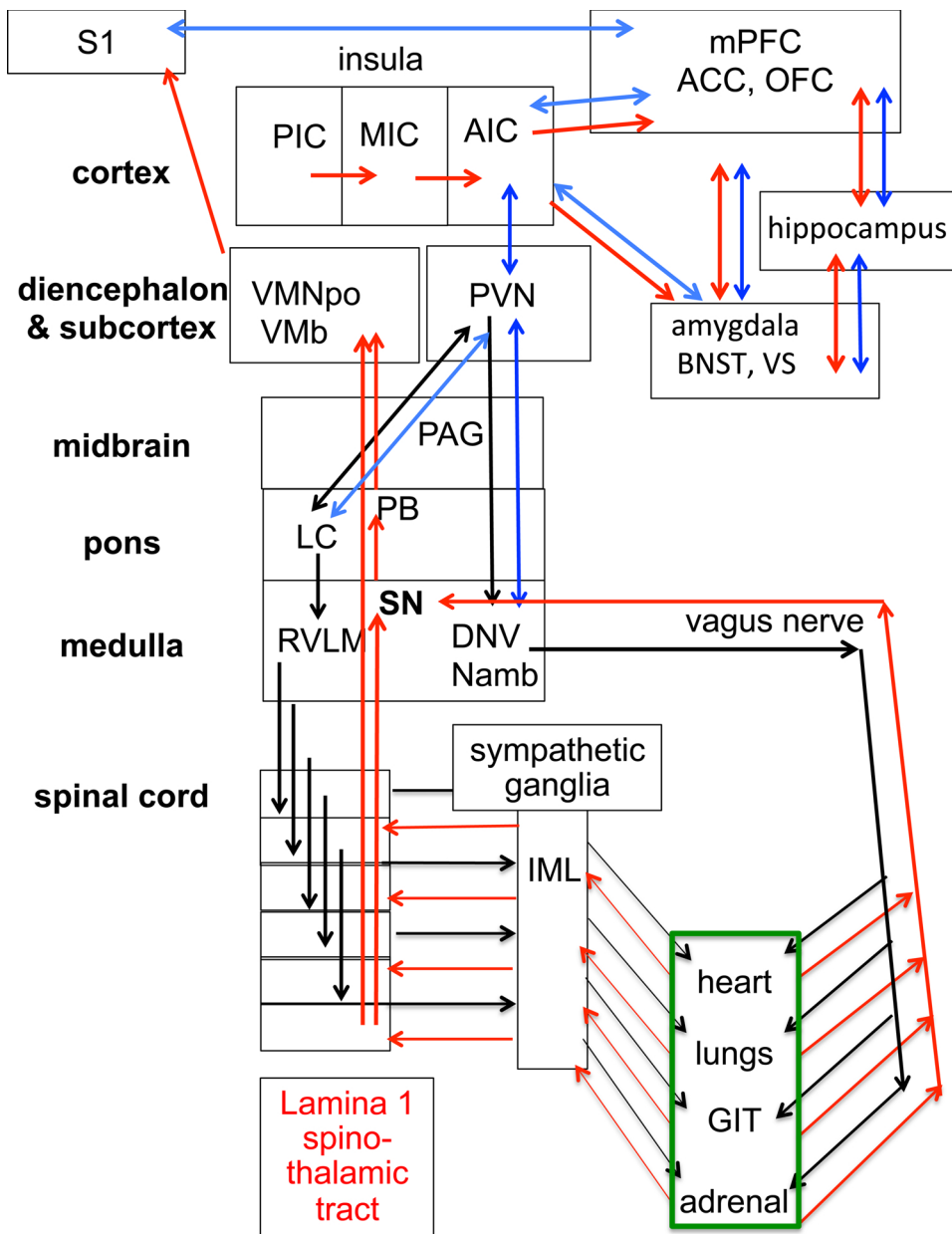

**Fig. 2.** Interoceptive feelings and emotions result from interactions between autonomic efferents, viscerosensory afferents, and their respective expression as centrally-generated descending predictions regarding intended bodily state, and ascending feedback of prediction errors. Depicted are a representative subset of structures and neural pathways involved in autonomic efferent outflow from the CNS (black arrows), autonomic, viscerosensory and somatosensory afferent information flow originating in the periphery and re-represented in forebrain (red arrows) and putative centrally generated, bidirectional predictive pathways for interoception, feelings and emotions (blue arrows). For simplicity, only a limited depiction of a complex connectivity is presented (e.g., without horizontal interconnections). Abbreviations: ACC, anterior cingulate cortex; AIC, anterior insular cortex; BNST, bed nucleus of the stria terminalis; DNV, dorsal nucleus of the vagus; IML, intermediolateral cell column; LC, locus coeruleus; MIC, middle insular cortex; mPFC, medial prefrontal cortex; Namb, nucleus ambiguus; OPFC, orbitofrontal cortex; PAG, periaqueductal gray; PB, parabrachial nucleus; PIC, posterior insular cortex; PVN, periventricular nucleus of the hypothalamus; RVLM, rostral ventrolateral medulla; S1, primary somatosensory cortex; SN, solitary nucleus; VMb, ventromedial nucleus of the thalamus; VMNpo, ventroposterior medial nucleus of the thalamus; VS, ventral striatum. Based upon Barrett and Simmons (2015), Craig (2002), Critchley and Harrison (2013), Damasio and Carvalho (2013). (For interpretation of the references to colour in this figure legend, the reader is referred to the web version of this article.)

reorganize to a defensive pro-pain state of organization, one that prioritizes salience of pain signals – the emotion of pain (Apkarian et al., 2011; Vachon-Preseu et al., 2016). Network reorganization also involves a maladaptive upregulation and engagement of emotion-processing regions – prefrontal regions, the anterior insula, anterior cingulate cortex, basal ganglia, thalamus, periaqueductal gray, post- and pre-central gyri and inferior parietal lobe – in pain processing, thereby amplifying the value of pain signals and maintaining the feeling of pain (Kuner and Flor, 2017; Vachon-Preseu et al., 2016).

### 6.3. Interoception and disgust

Disgust functions as a gatekeeper to the body to shield it from contamination with hazardous pathogens (Matchett and Davey, 1991). Hence, the experience of disgust is associated with various bodily sensations of expulsion, vomiting or nausea. Often, disgust demonstrates as an overwhelming experience, whose presence is robust and rapid but also subsides quickly (Rozin and Fallon, 1987). A sudden experience of unpleasant physiological signals is likely to evoke in an individual the awareness of feelings of disgust and inform them to

distance themselves from the source of disgust (e.g., taking a bite from a rotten apple).

Although certain universal disgust stimuli exist (e.g., feces, vomit, rotten food; Rozin and Fallon, 1987), what elicits disgust has evolved into several domains which are largely shaped by culture, society and personal experience. Thus, in addition to protecting individual health, disgust also functions to signal dangers to the cohesion of the social group as a whole. Disgust is then experienced toward transgressions of social norms (e.g., racism, pedophilia, bank fraud or lying politicians). Research showed that disgust indeed affects political preferences (i.e., conservatism; Billingsley et al., 2018) and drives moral convictions (Schnall et al., 2008). Interestingly, physiological reactivity toward various disgust elicitors all seem to be associated with the same psychophysiological correlates of disgust (e.g., activation of levator labii; van Overveld et al., 2009).

To facilitate survival, either of the self or the group as a whole, disgust and interoceptive processes are intertwined. Similarly to pain and empathy, disgust has consistently been linked with activation in the insula (Critchley and Harrison, 2013; Garfinkel and Critchley, 2013; Schienle et al., 2002). Activation of the insula is not disgust-specific

(e.g., Schienle et al., 2002) but may instead be linked to interoceptive awareness (Critchley et al., 2004). In support of this, patients with dementia with decreased bilateral insula gray matter volume exhibited disgusting behaviors and impairments in disgust recognition (Woolley et al., 2015). Presumably due to impaired interoception of bodily signals related to disgust, such patients no longer recognized disgust and were uninhibited in displaying disgusting behaviors. Further, in another fMRI study, activity in the insular cortices predicted emotional experiences of disgust (Harrison et al., 2010). These findings suggest that afferent visceral signals are associated with dynamic, continuous representations of physiological states in the insula and contribute to autonomic control over emotional states like disgust.

#### 6.4. Interoception and empathy, neural bases

Empathy is a basic human ability with affective and cognitive components. As a multidimensional concept that involves an affective and a cognitive level, empathy refers, respectively, to the ability to share another individual's emotional states and to infer that individual's experiential states (de Vignemont and Singer, 2006). The latter inferential ability, closely related to theory-of-mind constructs, may employ similar cycling of probabilistic inference with fed-back prediction error that has been proposed for cognitive, perceptual and emotional abilities (Saxe and Houlihan, 2017; Wu et al., 2018).

Bodily processes have been intimately linked to social-cognitive and affective functions such as empathy. Indeed awareness of bodily processes influences social awareness. Previous findings thus suggest that there may be an interdependence between interoceptive sensitivity (IS) and empathy, as demonstrated by empirical studies which investigated the links between IS and either affective or cognitive empathic responses (Ernst et al., 2013; Fukushima et al., 2011; Handford et al., 2013; Terasawa et al., 2014). The accurate perception of bodily states and their representation shape both affective and cognitive empathy, and afferent feedback from visceral activity may contribute to inferences about the affective state of others. Indeed detecting one's internal body signals strongly contributes to the awareness of oneself and is known to interact with emotional and cognitive processes.

As recently suggested, this perception enables us to be more empathic and to evaluate the body experience that other individuals experience as being more intense (Grynberg and Pollatos, 2015). This hypothesis is also coherent with the assumption that impaired access to one's own emotional state and feelings is directly associated with impaired simulation of the other's emotional state and feelings, leading to lower empathy.

However, people vary in the extent to which interoceptive signals reach awareness. This trait component might modulate both the subjective experience of emotion and subjects' ability to distinguish 'self' from 'other' in multisensory contexts (Ainley et al., 2015). Specifically, it was shown that, when viewing pictures depicting other individuals in pain, greater IS (determined by a heartbeat perception task) was associated with a greater estimated degree of pain (interpreted as representing cognitive empathy), as well as greater arousal and feelings of compassion representing affective empathy (Grynberg and Pollatos, 2015; however, see Ainley et al., 2015). This shared circuit also enables individuals to activate their own body representations of pain when observing someone in pain, leading to stronger empathic responses (Singer et al., 2009). Furthermore, IS contributes to emotional experience and psychophysiological response in terms of arousal: greater IS is associated with higher ratings of arousal and with greater heart rate deceleration in response to emotional stimuli that may induce an empathic experience (Pollatos et al., 2007). In fact, IS, the subjective experience of emotions, and cardiovascular arousal are associated with activation of similar brain regions (e.g., anterior insula and anterior cingulate cortex) (Critchley et al., 2004; Ernst et al., 2013). Additional neural substrates of empathy may include the brain's fronto-parietal network of mirror neurons (Iacoboni, 2009), theory of mind networks

(Kanske et al., 2015) and the full complement of agranular cortices (Barrett and Simmons, 2015). From the clinical perspective, it was shown that greater IS is associated with lower levels of alexithymia (Herbert et al., 2011). Increased activation in the above regions might explain the associations between high IS, low levels of alexithymia, and more intense emotional experience.

Finally, the potential impact of interoceptive awareness on the self/other distinction was also considered in the motor domain, as a specific form of "action empathic resonance" by focusing on action observation and imitation behavior (Ainley et al., 2014). Indeed, in automatic imitation, inhibition of imitation is a marker of an individual's success in distinguishing internally generated motor representations from those triggered by observing another individual's action. Potentially, high IS involves stronger interoceptive representations of the consequences of an action, implying higher empathy, greater motor reactivity in response to observed action and hence a greater tendency to imitate.

#### 6.5. Interoception and empathy, a psychosocial example with clinical application

Empathy is a critical process for surviving effectively in a complex society (Cripe and Frankel, 2017). Such empathic understanding is based upon "body wisdom", a distinct form of emotional intelligence subserved by the insula and lower level structures of the interoceptive network (Craig, 2009, 2011; Di Lernia et al., 2016). The posterior insula serves as a primary sensory cortex for representation of afferent interoceptive information that is re-represented, first, in the mid-insula where it is integrated with exteroceptive information and then in the anterior insula as more subjective, affect-laden sensations (Craig, 2002, 2009, 2016). This interoceptive network can generate an awareness of the body, which, along with the cognitive understanding, can mirror another's feelings resulting in the most genuine and clinically effective expression of empathy.

In medicine, it has been necessary to train learners to be empathic. Robert Smith and colleagues have developed an evidence-based patient-centered method for enhancing empathy in physicians (Fortin et al., 2018; Smith et al., 1998), a method associated with high patient satisfaction and improved health outcomes (Smith et al., 2006, 2009).

To be empathic, learners first elicit an emotion ("how does that make you feel?") and then listen long enough to understand it (Fortin et al., 2018). They then use variations of these empathic statements, recalled by the mnemonic NURS: Name the emotion ("that's been sad for you"), Understand the emotion ("I can sure understand that"), Respect the emotion ("thanks for helping me understand, you've been through a lot"), and Support the emotion ("We'll work on this together") (Fortin et al., 2018). Learners report that these empathic skills not only improve their doctor-patient relationships but also their personal relationships with, for example, parents, friends, and spouses.

## 7. Stress, endocrine systems and emotion

### 7.1. HPA axis

From cellular to behavioral studies, psychological stress has been extensively studied in the last decades to understand its causes, its physiology, and its effects on the body and the brain. Novelty, unpredictability, a decreased sense of control, and threat to one's ego are the characteristics that have been identified as triggers of a stress response (Dickerson and Kemeny, 2004; Mason, 1968). Upon perception of one of these characteristics, two stress systems are activated: the sympathetic-adrenal-medullar (SAM) axis and the hypothalamic-pituitary-adrenal (HPA) axis.

Stress triggers a quick reaction via the SAM system, where the hypothalamus signals to the adrenal medulla, which secretes catecholamines, notably adrenaline and noradrenaline. In parallel, the hypothalamus activates a slower system, the HPA axis. Corticotropin-

releasing hormone (CRH), released from the hypothalamus, binds to the anterior pituitary, which in turn secretes adrenocorticotropin hormone (ACTH). ACTH is released in the bloodstream and binds to its receptors on the adrenal cortex, which then releases glucocorticoids (GCs; cortisol being the main GC in humans). Recent discoveries suggest the presence, in the CNS, of a third, extra-hypothalamic, stress system involving noradrenergic and CRHergic signaling in structures such as the central nucleus of the amygdala and the bed nucleus of the stria terminalis, both part of the extended amygdala (Binder and Nemeroff, 2010; George et al., 2012; Ketchesin et al., 2017; Koob, 2013; Muller et al., 2003; Risbrough and Stein, 2006). This system may have particular importance in maintaining anxious versus acutely fearful states (Davis et al., 2010; Pole et al., 2009; Somerville et al., 2010).

GCs bind to mineralocorticoid receptors (MR or Type I) and glucocorticoid receptors (GR or Type II). Type I has a higher affinity to GCs than Type II (Reul and de Kloet, 1985). While Type I is mainly distributed in the limbic system, Type II is present in subcortical and cortical structures (Diorio et al., 1993; McEwen et al., 1986, 1986; McEwen et al., 1968; Meaney et al., 1985; Sanchez et al., 2000; Sarrieu et al., 1988). Importantly, Type II receptors are also involved in the negative feedback mechanism that regulates the HPA axis. In addition to the negative feedback at the level of the pituitary and the hypothalamus, the HPA axis is regulated by the hippocampus, the amygdala, and the medial prefrontal cortex. The amygdala, known for its role in fear detection, is the only one of the three regulators that activates the HPA axis (Herman et al., 2005). In contrast, the prefrontal cortex and the hippocampus play an inhibitory role on the HPA axis (Herman et al., 2005).

Given the high density of GC receptors in the amygdala, the hippocampus, and the prefrontal cortex, and the known cognitive functions of these brain regions, the role of GCs on memory, emotion processing, and emotion regulation has been extensively studied. Although stress and emotions are distinct concepts, it is important to keep in mind that they can both increase vigilance and arousal levels, and they can also activate the hormonal stress systems.

Acute stress increases the level of vigilance and favors emotionally charged responses to salient information. Acute stress also promotes memory consolidation, which ultimately results in better memory for emotional material than for neutral material (Cahill and McGaugh, 1995; Heuer and Reisberg, 1990). Studies have demonstrated that co-activation of the hippocampus with the amygdala results in this potentiated memory for emotional information (McGaugh et al., 1996; Roozendaal et al., 2008). Importantly, although emotional material is usually better remembered than neutral material, there are differences between emotionally-charged memories and neutral ones. High arousal levels result in a differential treatment of the environment where central information seems to have an advantage over peripheral information (Christianson and Loftus, 1991). Emotional information is also better remembered after a delay than immediately after encoding, whereas the neutral memories tend to decrease over time (Kleinsmith and Kaplan, 1963).

The relationship between stress and interoception is complex and bidirectional (Schulz and Voegelé, 2015). Whereas the subjective experience of stress is reported largely in terms of somatic sensations, chronic stress may dysregulate afferent interoceptive information (Schulz and Voegelé, 2015). Such abnormal interoception may be experienced in the form of augmented or fictive somatic sensations (Schulz et al., 2013; Schulz and Voegelé, 2015) or attenuated interoceptive sensitivity, such as stress-induced hypophagia (Fairclough and Goodwin, 2007). Other endocrine systems are involved in modulating emotion perception and processing and, as in the case of stress hormones, their effects on emotion may be exerted to a great extent via effects of interoception on mood states.

## 7.2. Contribution of other endocrine systems

In addition to the HPA axis, hormones of the hypothalamic-pituitary-gonadal (HPG) axis can play a significant role in emotional processing and emotion regulation. In females, the end products of the HPG axis are estradiol (E2) and progesterone (P4), whereas in males, this hormone is testosterone (T). While other tissues in the body, such as adipose tissue, can release precursors to steroid hormones, the primary release sites are the ovaries in females and testes in males. E2 and T provide negative feedback to the pituitary and the hypothalamus to reduce further production of these hormones. In cycling females, E2 and P4 levels fluctuate – the midpoint of the cycle has high levels of E2, causing ovulation. In the luteal phase of the cycle, E2 levels go into withdrawal, which is often associated with anxiety and depression during the few days leading up to menstruation (Nillni et al., 2011, 2015), and some women with high symptoms suffer from premenstrual dysphoric disorder (PMDD) (Hantsoo and Epperson, 2015; Nillni et al., 2011). Further, major lifespan changes in the hormonal milieu of females, such as puberty and menopause, are often related to emotional lability (Hantsoo and Epperson, 2015; Santoro et al., 2015).

Evidence suggests that fluctuating E2 levels may influence physiological and neural reactivity to threatening stimuli, providing one possible mechanism for women's heightened risk of mood and anxiety disorders. For example, trauma-exposed women with low E2 levels (both naturally cycling and post-menopausal) show impaired fear regulation (Glover et al., 2013) and deficient extinction of fear (Glover et al., 2012). Women with lower estrogen also show greater connectivity between the amygdala and dorsal anterior cingulate cortex (Engman et al., 2016), a region associated with increased fear expression and arousal. On the other hand, in a brain imaging study of fear conditioning and extinction, naturally cycling women during a high-estrogen phase showed greater activation of fear-processing regions than men or women with low estrogen levels (Hwang et al., 2015). Similarly, pregnancy may be a particularly vulnerable time for females, as circulating estrogens and cortisol increase over the course of pregnancy. A recent study showed that pregnant women reported greater levels of anxiety symptoms than non-pregnant control women, and showed impaired regulation of fear responses (Michopoulos et al., 2014). Further studies are needed in order to investigate the possibility of an inverted U-shaped dose response relationship between estrogen and poor emotion regulation, and to outline whether there are specific circumstances (e.g., pregnancy, menopause) in which high versus low levels of E2 promote anxiety.

In addition to HPA and HPG endocrine axes, other hormones may be relevant for emotion. Proteins found in blood, such as oxytocin, vasopressin, neuropeptide Y (NPY), and pituitary adenylate cyclase-activating peptide (PACAP), can play a role in endocrine influences on emotion. Oxytocin, colloquially known as the “love hormone” has been associated with affiliative behavior between parents and infants, and between male and female partners (Young et al., 2001). Oxytocin is thought to promote attachment and is critical for early survival of neonates (Rilling and Young, 2014). In contrast to oxytocin, vasopressin seems to increase aggression and competition, especially in males (Johnson and Young, 2017). Seminal work with monogamous voles has pointed to this critical role of oxytocin and vasopressin (Johnson and Young, 2017; Young et al., 1998). PACAP has been associated with the stress response as it is also released by the hypothalamus and pituitary in response to stress. Further, PACAP may interact with E2 levels in females to increase symptoms of anxiety and posttraumatic stress disorder (PTSD) (Mercer et al., 2016; Ressler et al., 2011). Neuropeptide Y appears to promote resilience, especially in males. For example, NPY levels are higher in special forces military with lower levels of distress or cortisol levels (Morgan et al., 2000). Interoceptive effects of non-HPA axis hormones have focused largely on oxytocin and vasopressin (Quattrocki and Friston, 2014; Rinaman, 2007). For example, oxytocin circuits may normally generate interoceptive sensations that promote

attachment. However, disruption of these circuits may increase vulnerability to mood and anxiety disorders (Hurlmann and Scheele, 2016) as well as the social deficits in autism (Quattrocki and Friston, 2014), the latter possibly associated with impaired predictive coding of representations of emotions in self and others. However, Quattrocki and Friston's hypothesis that abnormal development of the oxytocin system leads to impaired interoceptive ability resulting in autistic symptoms has been questioned by Brewer et al. (2015). These investigators instead suggest that impaired interoception leads to alexithymia, a condition that is not shared by all individuals with autism and which can occur independently of autism. More recently, intranasal administration studies have implicated oxytocin in the control of switching attention between interoceptive and specifically social exteroceptive cues with exogenous oxytocin enhancing attention to the latter (Yao et al., 2018). The Social Salience Hypothesis (Shamay-Tsoory and Abu-Akel, 2016) proposes that oxytocin increases sensitivity of mesolimbic reward circuits to social stimuli and, depending on individual characteristics, such an attentional shift can have highly variable behavioral effects. For example, while generally reducing interoceptive accuracy in alcohol users, oxytocin improved performance on a heartbeat discrimination task requiring shifts between intero- and exteroception only in heavy drinkers who are believed to specifically suffer difficulty in making such shifts (Betka et al., 2018).

## 8. Reward system and emotion

All living beings pursue two essential biological objectives: their own survival and the preservation of their species. Human behaviors have evolved reward mechanisms that contribute to evolutionary fitness with feelings of pleasure, motivating individuals to repeat actions that increase the likelihood of survival and reproductive success. Achieving these goals is based on the satisfaction of certain instincts such as sexual behavior, nursing, eating and drinking behavior, that are motivated by activation of the brain's reward mechanisms. Specifically, rewards are positive reinforcements that increase the frequency of approach and goal-directed behavior. For instance, food and sex are the primary rewarding stimuli that, by virtue of their intrinsic properties, result in positive reinforcement. In general, rewards imply positive hedonic consequences (pleasure), learning cues, and assigning value and motivational status (salience). They generally contrast with negative reinforcement and punishments which increase the frequency of withdrawal behavior.

The reward system is thus an indispensable element for life and allowed the evolution of animals and humans. Moreover, it is fundamental for particular regions of the brain to assign an emotional/motivational valence to any stimuli (internal and external) by determining whether they are rewarding and should be approached or are aversive and should be avoided.

Reward mechanisms are supported by specific neuroanatomical and neurophysiological circuits that consist of two components – a “wanting” or incentive salience system and a “liking” system (Berridge and Robinson, 2016). Mesolimbic dopaminergic pathways are the major substrates of incentive salience for natural reward behaviors (Schultz, 2015). The central feature of the incentive salience circuit is the release of dopamine (DA) from the ventral tegmental area (VTA) neurons into limbic brain regions that control perception and prediction of rewarding stimuli. VTA neurons have major projections to the prefrontal cortex (PFC) and to the nucleus accumbens (NAcc), but also project to the hippocampus, amygdala, and several other forebrain regions. This mesolimbic circuit is distinct from circuits that generate pleasure (“liking”) which rely on smaller, more diffuse neural loci activated by a variety of neurotransmitters (e.g., opioids) (Berridge and Kringelbach, 2015; Berridge and Robinson, 2016). Together these systems integrate information that drives processing and storage of memories and decision-making by the hippocampal formation and prefrontal cortex respectively. And both are involved in reward-related

emotions and reinforcement-based learning (Schultz, 2015).

According to Gray's BIS–BAS model, limbic circuitry generates emotions that are relevant to approach (reward) and withdrawal (inhibition) behaviors (Gray, 1981). The behavioral activation system (BAS) activates behavior in response to conditioned, rewarding and non-punishment stimuli. BAS is mediated by dopaminergic pathways from the VTA to the ventral striatum (Fowles, 1994). In contrast, the behavioral inhibition system (BIS) seems to inhibit behavior in response to novel stimuli which are feared and aversive, thus the BIS is responsive to non-reward stimuli, preventing individuals from negative or painful outcomes.

Internal or external conditions may maladaptively increase reward processing to induce disorders such as overeating or addiction to drugs or sex. Conversely, deficiency in reward processing contributes to the anhedonic symptoms of mood disorders like depression (Berridge and Kringelbach, 2015). Thus deficits and maladaptive responses of the network of interconnected brain regions responsible for reward processing and motivated behavior underlie a variety of emotional disorders (Harmon-Jones and Allen, 1997).

In the addictions, alterations of the brain's motivation and reward systems result in persistence of maladaptive behaviors. Salience attribution is biased toward rewarding stimuli and addictive behavior is exacerbated by neurocognitive impairments as well as compromised metacognition and self-awareness (Goldstein and Volkow, 2002). Addiction patients are characterized by insensitivity to future consequences (Bechara, 2005); they are unaware of future positive or negative consequences since they are driven by immediate rewards. Behavioral addictions such as pathological gambling behavior or internet addiction disorder share the same dysfunction in reward mechanisms and cognitive control present in substance use disorders (Reuter et al., 2005).

Finally, it has been demonstrated that normal levels of BAS functionally affects a positive emotional attitude, but extreme levels of BAS are linked to impulsivity disorders, Attention-Deficit Hyperactivity Disorder, excessive risk-taking and antisocial behavior. In contrast, the BIS system appears to be preferentially activated by stimuli conditioned as being aversive, thus the BIS is responsive to non-reward stimuli, preventing individuals from negative or painful outcomes. A dysfunction in the direction of hyperactivity of this system could generate pathological disorders such as Generalized Anxiety Disorder or Obsessive–Compulsive Disorder. It was also recently demonstrated that stress-induced changes in reward network activity underlying both normal and pathological behavior also may cause changes in gene expression (Manning et al., 2017).

Both neural arms of reward systems circuitry (Berridge and Kringelbach, 2015) – the dopaminergic mesolimbic incentive salience circuit and the more diffuse system that produces the hedonic experience of reward – produce interoceptive sensations experienced as urges/craving and physical pleasure respectively (Berridge and Kringelbach, 2015). These sensations play a key role in maintaining addictive behavior (Paulus and Stewart, 2014; Paulus et al., 2009). Specifically, changed physiological conditions as a result of addiction may alter the reward value of stimuli (alliesthesia) such that behaviors that would previously be aversive or neutral become rewarding (Paulus et al., 2009). For example, excessive stimulation of reward circuitry may favor continued drug use to avoid aversive states (negative reinforcement) resulting from allostatic potentiation of stress circuitry (George et al., 2012; Koob, 2013).

## 9. Immune system and emotion

Being sick involves many feelings, especially body feelings such as fatigue, soreness, nausea, headache, and chills. Together, these words describe the broad feeling of “sickness.” The study of the feeling of sickness is somewhat unique, as it lies at the intersection of psychology, neuroscience, and immunology – a relatively new field known as



psychoneuroimmunology (Ader et al., 1991; Maier et al., 1994). Here, we briefly review the science behind the feelings of sickness, referred to as sickness behavior or the sickness response (Dantzer and Kelley, 2007), which have intriguing implications for the relationship between inflammation and psychopathology.

The vertebrate immune system can be described according to two divisions: the acquired immune system and innate immune system. The acquired immune system responds to newly-contacted pathogens by creating antibodies and then storing an immunological memory. The innate immune system, on the other hand, is the more evolutionarily ancient division that responds in basically the same fashion to every pathogen or immune challenge. The behavioral component of this innate immune response evolved to ensure that the body's resources are diverted toward dealing with immune challenges. This is largely accomplished by triggering the subjective feeling of being sick, which inhibits motivation to engage in energy-expending behaviors (e.g., feelings of fatigue and soreness prioritize rest). Here, we will describe one key pathway by which foreign pathogens can affect behavior and subjective feelings: cytokine-to-vagus-to-brain.

When local or circulating innate immune cells such as macrophages or monocytes recognize a foreign antigen, they release both lipid and protein signaling molecules. Important examples of proteins crucial to the “sickness response” are proinflammatory cytokines (Dantzer and Kelley, 2007; Kelley et al., 2003; Watkins and Maier, 2000). Proinflammatory cytokines are a class of proteins that function as innate immune system signaling molecules, and include interleukins (IL) such as IL-1beta and IL-6 as well as tumor necrosis factor alpha (TNF-alpha).

Proinflammatory cytokine signaling after infection is communicated to the brain via different pathways (Miller and Raison, 2016), often broken down into “humoral pathway” (cytokines flow through blood to affect the brain) and “neural pathway” (cytokines are detected by nerves to affect the brain). In the humoral pathway, peripheral cytokines cross into the brain side of the blood–brain barrier via diffusion across circumventricular organs and via soluble transport molecules. However, cytokines are relatively large, hydrophilic polypeptide protein molecules and therefore do not easily passively diffuse in large quantities across the blood–brain barrier. Furthermore, cytokines are not generally released in large enough quantity to act in an endocrine fashion (the term “interleukin” literally means “among white blood cells”).

The neural pathway allows for direct and rapid communication between peripheral immune response and brain. Upon detection of proinflammatory cytokines by chemoreceptors on the afferent vagus nerve (and to a lesser extent, the trigeminal nerve), an afferent signal to the brain triggers sickness feelings. We know this mechanism from a series of clever, programmatic animal model studies reviewed in detail elsewhere (e.g., Goehler et al., 2000; VanElzakker, 2013). For example, when an immunogenic substance like lipopolysaccharide (LPS, an adjuvant that triggers an innate immune response by mimicking bacteria) is injected into a rat, the rat “acts sick” – it moves around less, socializes less, and shows evidence of pain sensitization and fever. However, these “sickness behaviors” are not expressed if the vagus nerve is cut (Maier et al., 1998). In essence: without a functioning sensory vagus nerve, the rat's brain does not know that its body is sick. The central nervous system therefore uses vagus and trigeminal nerves as sensory organs to monitor the peripheral immune milieu in order to trigger sickness feelings.

In rodents, we can only measure the behavioral and objective physiological changes that result from immune challenge but we can ask human study participants about subjective feelings. Immune adjuvant injection into the human bloodstream leads to sickness feelings such as fatigue, headache, and muscle pain (Eisenberger et al., 2010; Hannestad et al., 2011; Reichenberg et al., 2001; Sandiego et al., 2015), even when the immune adjuvant does not easily cross the blood–brain barrier.

Infectious illness also often coincides with feelings of anxiety

(Goehler et al., 2007), and the shared pathways between inflammatory signaling and stress-related signaling may be an important reason. The vagus nerve is central to both immune signaling but also stress signaling. For example, adrenaline (epinephrine) does not easily cross the blood–brain barrier and its effect on the brain is largely due to its detection by the vagus nerve. These overlapping pathways make sense, given the evolutionary likelihood of environmental threat coinciding with physical injury and subsequent infection (Miller and Raison, 2016). Regions such as anterior cingulate cortex, insular cortex, bed nucleus of stria terminalis, amygdala, and hypothalamus are known to be involved in both emotional states like stress and anxiety, as well as viscerosensory signals related to sickness, pain, and hunger.

Glial cells such as microglia, astrocytes, and oligodendrocytes are the neuroimmune cells of the central nervous system and affect the activity of neurons depending on immune signaling. When microglia (and probably to a lesser extent astrocytes) are activated by an immune challenge or immune signaling, they “activate,” meaning they undergo morphological and functional changes. The purpose of these activation changes is (1) to remove damaged cells via phagocytosis, (2) to signal to other immune cells and (3) to support nearby neurons with neuroexcitation (a response that can turn cytotoxic). During microglia activation, the translocator protein is transcribed and translated. While its specific function is not entirely understood, the translocator protein is used as a biomarker for microglia activation in human imaging studies. Translocator protein positron emission tomography (PET) scanning studies have provided evidence that a peripheral immune challenge that causes feeling of being sick is also associated with glial activation on the brain side of the blood–brain barrier. Sandiego et al. (2015) injected healthy humans with LPS, and found an increase in self-reported sickness symptoms such as fatigue, headache, muscle pain (soreness), and shivering, and a decrease in self-reported health-related descriptors such as alertness, energy, focus, pep, and social interest. At the same time, there was a significant upregulation of PET radioligand binding of the translocator protein in a wide swath of brain structures, including the caudate nucleus, cerebellum, and frontal and parietal cortices.

Perhaps related to inflammatory processes, the translocator protein is increased in neurological conditions such as Alzheimer's disease (Kreisl et al., 2016), Parkinson's disease (Gerhardt, 2016), chronic fatigue syndrome (Nakatomi et al., 2014), traumatic brain injury (Folkersma et al., 2011), and multiple sclerosis (Park et al., 2015). Interestingly, the translocator protein is also over-expressed in psychiatric disorders such as major depression and suicidal ideation (Holmes et al., 2018) and schizophrenia (Selvaraj et al., 2018; see also Notter et al., 2017; Barichello et al., 2017). As it becomes more and more clear that inflammation, infection, and dysbiosis can play a role in neurological and psychiatric disorders, these findings provide an interesting opening into what may soon become an accepted truism: the immune response is an important factor in cognitive, emotional, and mood symptoms of brain-based disorders.

## 10. Consciousness and emotion

### 10.1. Emotional expression and experience under reduced consciousness

Patients sustaining severe brain injury may be unconscious for some time, quickly regain full consciousness, or remain in an altered state of consciousness temporarily or permanently. Unresponsive patients are awake but not aware, they only show reflex movements (Laureys et al., 2010). Minimally conscious patients present signs of awareness such as visual pursuit or responses to command (Giacino et al., 2002) and they can also perceive pain (Boly et al., 2008). Once patients achieve functional communication or object-use, they are said to have emerged from the minimally conscious state.

By definition, patients with disorders of consciousness are unable to accurately communicate, and hence, it is impossible for them to express

their feelings. Studying emotional states in this population is thus very challenging. There is also little evidence to date to attest that behaviors like grimaces or cries are related to a specific emotional state in these patients. Indeed, these behaviors can follow pathological activation of subcortical pathways and may be unrelated to emotional situation or painful stimulation. Only if these behaviors are contextualized and repeated, one can infer that they represent a conscious emotional state.

Neuroimaging techniques have been gradually used to measure brain activity in patients with disorders of consciousness. Active paradigm studies have shown that brain activation patterns indicating responses to command can be found in around 10–20% of patients with unresponsive wakefulness syndrome (Cruse et al., 2012; Monti et al., 2010). Some unresponsive patients may also retain residual emotional abilities to react to the signals of pain in others (Yu et al., 2013). In a recent study, a patient diagnosed with an unresponsive wakefulness syndrome exhibited intact emotional responses to jokes as assessed by recordings of facial electromyography (Fiacconi and Owen, 2016). In another study, post-comatose patients showed a larger skin conductance response to auditory emotional stimuli as compared to neutral sounds (Daltrozzo et al., 2010). Similarly, in one patient who received central thalamic deep brain stimulation, modulations of oscillatory thalamic activity were observed in response to the voices of her children, which suggest an involvement of the central thalamus in processing emotional information (Wojtecki et al., 2014). Familiar voices also induced stronger EEG changes (i.e., alpha desynchronization) than unfamiliar voices in a few patients with altered state of consciousness (Del Giudice et al., 2016).

Other salient emotional stimuli have been employed in clinical routines such as the patient's own face (with a mirror) and the patient's own name. These two items elicit more behavioral responses than a person moving into the room or the sound of a bell (Cheng et al., 2013; Thonnard et al., 2014). At the brain level, the patient's own name has been shown to elicit stronger brain activation than any other names in patients with disorders of consciousness (Fellinger et al., 2011; Schnakers et al., 2008).

Music is another important stimulus that has been increasingly employed at the bedside of severely brain-injured patients. Emotionally pleasurable music can activate the dopaminergic system (which is severely impaired in these patients), by inducing changes in the limbic and paralimbic system, which can bring beneficial effects on consciousness recovery (Kotchoubey et al., 2015). Music has been shown to enhance arousal and attention in some patients (O'Kelly et al., 2013). At the neurophysiological level, music seems to decrease relative power of slow EEG rhythms, increase EEG amplitude in the alpha and theta bands, and enhance cerebral response to the patients' own name (Castro et al., 2015; O'Kelly et al., 2013; Sun and Chen, 2015). At the neuroimaging level, music therapy tends to increase metabolic brain activity in the frontal, hippocampal and cerebellar areas, and to induce stronger functional connectivity in the auditory network and the external awareness network (Heine et al., 2015; Steinhoff et al., 2015). These preliminary findings provide some evidence for positive effects of music therapy interventions but these should be replicated in controlled studies on larger samples of patients.

Brain–heart interplay has also been recently investigated, mainly showing that patients in minimally conscious state have higher heart rate variability complexity compared to unresponsive patients during rest and after noxious stimulations (Leo et al., 2016; Riganello et al., 2018, 2019; Tobaldini et al., 2018). The complexity of heart rate variability has also been correlated to brain connectivity in the central autonomic networks as measured with resting state fMRI (Riganello et al., 2018). In a cohort of 127 patients who were presented with auditory oddball stimuli, heart rate and heart rate variability were however not different between these two patients' groups, but global regularities induced a phase shift of the cardiac cycle only in minimally conscious patients (i.e., shorter interval between the auditory stimulation and the following R peak when there was a violation of the

auditory rule) (Raimondo et al., 2017). These findings suggest a link between residual cognitive processing and the modulation of autonomic somatic responses, with less complex autonomic response in unresponsive patients, and thus a potential way to differentiate between conscious and unconscious patients. Heart rate variability may also reflect the affective and physiological aspects of pain in this patient population.

All in all, research on emotions in altered state of consciousness after brain injury is still scarce and needs more investigations. The degree of preservation of interoceptive awareness in reduced conscious states is a challenging but important question. The notion of nociception as relatively preserved is implied in testing for response to pain stimuli. In addition, responses to musical interventions, when present, may also suggest relative preservation of hedonic experiences which, as described above, have a strong interoceptive component. To examine normal physiological states of reduced consciousness, sleep can provide us with additional insight.

## 10.2. Sleep, dreaming and emotion

Emotional experience is a ubiquitous component of dreams (Merritt et al., 1994; Nielsen and Levin, 2007). Although dreaming occurs throughout sleep (Nielsen, 2000), awakenings from REM sleep show greater frequency of dream recall and result in longer, more vivid and more emotional dream reports (Hobson et al., 2000). Positron emission tomography (PET) studies have identified a distinct midline anterior paralimbic area that becomes selectively activated during REM sleep, often to levels similar to or exceeding waking, following the more widespread forebrain deactivation (relative to wakefulness) during NREM sleep (Braun et al., 1997, 1998; Maquet et al., 1996; Nofzinger et al., 1997, 2004, reviewed in Maquet et al., 2005; Pace-Schott and Picchioni, 2017; Perogamvros et al., 2013). This REM activation area encompasses many of the structures implicated in the experience and expression of emotion including circuitry controlling fear and fear regulation, reward and social cognition and instinctive, evolutionarily important emotions such as aggression, anger and fear (reviewed in Desseilles et al., 2010; Hobson et al., 2000; Pace-Schott et al., 2015a; Pace-Schott and Picchioni, 2017). Emotions perceived during dreaming have been characterized as predominantly negative and focused on fear and anxiety (Merritt et al., 1994; Nielsen et al., 1991; Revonsuo, 2000) although it has also been argued that positive emotions are underestimated due to the powerfully biasing effects of negative salience on dream recall (Fosse et al., 2001; Schredl and Doll, 1998). Dreamed emotions often qualitatively differ from the same emotions in wakefulness. For example, nightmares clearly represent an intensification of fear and anxiety (Levin and Nielsen, 2007). However, it is also common to dream of circumstances that would elicit strong emotion in wakefulness but produce little emotional response in the dream (Foulkes et al., 1988). It has been suggested that reduced emotionality results from REM atonia and the absence of motoric feedback (Perlis and Nielsen, 1993), or from active prefrontal inhibition akin to extinction memory (Levin and Nielsen, 2007). Additionally, there is reduction of homeostatic regulation of autonomic (respiratory, cardiovascular, thermal) physiology during REM (Parmeggiani, 1985) that may similarly reduce afferent feedback from the periphery to interoceptive regions of the CNS. During sleep, and especially REM, in the absence of afferent input from the periphery, cortically generated predictions of sensory percepts generate the inferred virtual reality that cannot be modified by prediction errors resulting from exteroception (Hobson and Friston, 2012; Hobson et al., 2014). In this regard, it is notable that the sensory composition of dreams is strongly weighted toward hallucination of the exteroceptive visual sense (Hobson et al., 2000) and remarkably underrepresented by the chemical senses such as gustation or olfaction (Zadra et al., 1998). Nonetheless, the relatively common experience of movement in dreams suggests that fictive proprioceptive sensations are also hallucinated (Hobson and Friston, 2012; Hobson

et al., 2014; Porte and Hobson, 1996). Strong interoceptive sensations, such as painful stimuli, may be incorporated into dream scenarios although with a frequency much less than what would be expected based upon waking experience (Nielsen et al., 1993; Raymond et al., 2002). As in the case of fictive exteroception, interoceptive and emotional states may continue to be generated by the selectively activated agranular cortices (which make up much of the anterior paralimbic REM-activation area). In this regard, the dearth of interoceptive sensation in dreams is puzzling.

## 11. Physiological mechanisms of emotion regulation

### 11.1. Conscious emotion regulation

Emotions often serve a practical purpose (e.g., conveying important information about the environment and triggering appropriate physiological responses). However, sometimes emotions need to be controlled in order to improve the wellbeing of the individual feeling the emotion or to allow the individual to achieve social goals. It is important to understand how emotions can be regulated, either explicitly or implicitly, and how attempts at emotion regulation may affect the individual. Emotion regulation involves all the skills and abilities which individuals use to increase, maintain or decrease experienced emotions. A comprehensive definition states that emotion regulation is “the process of initiating, avoiding, inhibiting, maintaining, or modulating the occurrence, form, intensity, or duration of internal feeling states, emotion-related physiological, attentional processes, motivational states, and/or the behavioral concomitants of emotion in the service of accomplishing affect-related biological or social adaptation or achieving individual goals.” (Eisenberg and Spinrad, 2004).

According to Gross (1998b), individuals can apply these emotion regulation strategies consciously, but may also have learned via prior experiences to automatically respond to the occurrence of emotions in a certain way. Emotional self-regulatory processes can influence emotions at any stage of the emotion generative process. Gross proposed the Process Model of emotion regulation (Gross, 1998b; John and Gross, 2004), which divides emotion regulation into the two broad categories of “antecedent-focused” and “response-focused” strategies. Antecedent-focused strategies include processes enacted before an emotion is fully experienced (e.g., reappraising an emotional experience) whereas response-focused strategies are enacted after the emotion has already been felt (e.g., masking a facial display; Gross, 1998b).

Three representative types of emotion regulation are cognitive strategies, mindfulness training, and biofeedback all three of which, and especially the latter two, are extensively used to treat emotional distress or pathology in the clinic. Cognitive strategies facilitate processing and management of emotional information and are often employed spontaneously as part of an individual's coping strategies. The most well-studied cognitive strategies are cognitive re-appraisal and expressive suppression (Gross, 2007). Cognitive re-appraisal, a mainstay of cognitive behavioral therapy (CBT), refers to the ability of the individual to view emotion-inducing stimuli in such a way that their emotional meaning is changed. In other words, altering the emotional impact by learning to view emotional events from a different perspective and re-interpret their significance. Expressive suppression refers to the ability of the individual to inhibit, change or mask the expression of individual emotions. Unlike reappraisal, suppression can generate adverse physical and psychological responses (e.g. heightened stress). Following the Process Model, re-appraisal can be seen as antecedent-focused whereas expressive suppression is response-focused (Richards and Gross, 2000).

Clinically, cognitive re-appraisal is associated with positive effects on various domains, such as smoking cessation (Kober et al., 2010), decreasing impulsive buying (van Overveld, 2016), reducing risk-taking (Heilman et al., 2010), and improving sexual functioning (van Overveld and Borg, 2015) or task focus (Wallace et al., 2009). In contrast,

expressive suppression can have negative effects (e.g., Richards and Gross, 2000), which supports the view that response focused strategies like suppression drain cognitive resources significantly more compared to antecedent focused strategies (Richards and Gross, 2000).

Another type of learned emotion regulation is achieved through mindfulness training. Mindfulness is defined as a ‘state of non-judgmental, present-oriented awareness with a high degree of acknowledgment and acceptance of emerging emotions and thoughts’ (Kabat-Zinn, 1990). Mindfulness training involves training exercises from Buddhist traditions but stripped of their philosophical and religious contexts. Overall, mindfulness training teaches individuals to become more aware of existing thoughts and emotions, and manage them properly. It is commonly offered in structured programs which require weeks of intensive training and practice, guided by a coach in weekly sessions (Segal et al., 2002). In academic studies, mindfulness training is consistently associated with positive effects on emotion regulation (Chiesa et al., 2013; Holzel et al., 2011). Neuroscientific studies identified that mindfulness training was associated with improved brain connectivity (Kilpatrick et al., 2011) and activity in structures related to emotion regulation (Holzel et al., 2011). Interestingly, even brief interventions (e.g. a single meditation session) already demonstrated positive short-term effects (Chiesa et al., 2013; Leyland et al., 2019). Mindfulness demonstrated positive effects on various behaviors, such as stress (Chiesa and Serretti, 2009; Weinstein et al., 2009), depression and anxiety (Blanck et al., 2017), weight loss (Ruffault et al., 2017), and medication adherence (Salmoirago-Blotcher and Carey, 2018). While generally mindfulness is associated with enhanced emotion regulation, e.g., in negative affect (Khoury et al., 2015; Leyland et al., 2019), meta-analyses also show that effect sizes vary significantly between studies (e.g., Baer, 2003; Bohlmeijer et al., 2010). Further, it should be noted that, in addition to emotion regulation, the full definition of mindfulness entails a wide range of skill trainings, from attention training, to cognitive and emotional awareness, and meditations on compassion and kindness. Consequently, author definitions of mindfulness vary across studies. Unsurprisingly, mixed findings on the effects of mindfulness are thus also observed. Additionally, long-term effects, what in particular constitutes the core ingredients of the efficacy of mindfulness training or how mindfulness compares to other treatments in robust randomized clinical trials have also yet to be established (Chiesa and Serretti, 2009).

A third type of conscious emotion regulation uses biofeedback to increase interoceptive awareness of physiological cues within the body. Using physiological sensing technologies (e.g., ECG, skin conductance, EEG), individuals learn to recognize physiological states as they occur (e.g., increased heart rate, or sweating) and manage them effectively utilizing this direct feedback. Studies show that improving interoceptive skills is associated with enhanced emotion regulation skills. For example, interoceptive training enhanced performance in financial traders, whose job requires them to manage emotions effectively during trading decisions (Kandasamy et al., 2016). While biofeedback is an established method to strengthen weakened physiological processes (e.g., hand strength weakness; Garcia-Hernandez et al., 2018), it can also be used to affect psychological states, such as emotions (e.g., anxiety; Vitasari et al., 2011) or attention (Fehmi and Shor, 2013) and thus provides a valuable tool in psychotherapy (Clough and Casey, 2011; Lehrer, 2018). Given the increasing availability of wearable devices that focus on awareness of bodily cues (e.g., smartwatches that measure heart rate or monitor sleep patterns), this research promises increasing utility (e.g., self-treatment programs).

A shared component across these three trainable emotion regulation strategies is emotional awareness. Emotion regulation requires recognizing emotional states at an early stage. These strategies increase awareness of interoceptive feelings that presage full expression of an emotional experience, either by tuning sensitivity (e.g., mindfulness) or in a technology assisted manner (e.g., biofeedback). This is an important and perhaps crucial feature of emotion regulation. Research



shows that emotions affect our decision-making processes (e.g., Lerner et al., 2004). Heightened emotional awareness can thus help individuals to properly manage their emotions before they can negatively affect behavioral and cognitive processes.

### 11.2. Automatic emotion regulation

Although early research on emotion regulation asked participants to consciously control their emotions using specific emotion-regulation strategies (e.g., Gross, 1998b), later work began to focus on the effects of automatic, or implicit, emotion regulation (e.g., Mauss et al., 2007a,b; Schmeichel and Demaree, 2010). Automatic emotion regulation (AER) is defined as, “goal-driven change to any aspect of one’s emotions without making a conscious decision to do so, without paying attention to the process of regulating one’s emotions, and without engaging in deliberate control” (Mauss et al., 2007a, p. 3). Individuals report using AER frequently (e.g., Gross et al., 2006), and yet are often unaware when they are using AER strategies (e.g., Schmeichel and Demaree, 2010). As a result, researchers should appreciate that the influence of emotional stimuli can be both direct (i.e., reflecting emotional reactivity) and indirect (e.g., reflecting emotion regulatory processes; Kappas, 2011). It has been found that there are individual differences in who is more likely to automatically regulate their emotions, and that such regulation has both affective and physiological effects.

Some people are more likely than others to use AER. Individuals with higher levels of RSA are more likely to automatically reappraise emotional stimuli (e.g., Volokhov and Demaree, 2010). This is consistent with the notion that RSA, also referred to as high frequency heart rate variability (HF HRV), reflects self-regulatory ability (e.g., Thayer and Lane, 2000), and is also consistent with the finding that people with higher RSA evince less negative affect displays to negative emotional stimuli (i.e., they automatically regulate their facial expressions; Demaree et al., 2006). RSA serves as an index of vagal or parasympathetic autonomic tone. By opposing the excitatory influence of the sympathetic autonomic outflow (Porges, 2011; Porges and Carter, 2011), higher levels of RSA are believed to predict an enhanced ability to self-soothe and self-regulate stress. By definition, in AER, afferent cardiovascular information would occur below the level of consciousness. Interestingly, however, it has also been found that individuals with better interoceptive perception display greater RSA in experimental social interaction (Ferri et al., 2013). As a second example, Schmeichel and Demaree (2010) found that people with greater working memory capacity (WMC) are more likely to use AER strategies. Specifically, people with higher WMC were more likely to claim having knowledge of fictitious people, places, and things following ego threat, and they felt emotionally more positive as a result of claiming such knowledge. The notion that people with higher WMC are more likely to effectively use emotion regulation strategies has been replicated (e.g., Bridgett et al., 2013; Hofmann et al., 2008; Thiruchselvam et al., 2012), and is intuitively pleasing in that they would not only have better cognitive outcomes (for a review, see Barrett et al., 2004), but also better emotional ones. Notice here that not only are there differences in terms of who uses AER (i.e., people with higher WMC), but there are also different emotional trajectories/outcomes depending on whether or not AER was used.

The use of AER also has profound affective and physiological effects. Affectively, AER has been used to combat felt negative emotion coming from such sources as ego threat (Schmeichel and Demaree, 2010), anger provocation (Mauss et al., 2007b), and social exclusion (DeWall et al., 2011). Affective effects include both reducing the impact of negative emotional stimuli and enhancing recovery from the emotionally-salient event (e.g., Demaree et al., 2006). Physiologically, it has been hypothesized that antecedent AER strategies produce activation in the orbitofrontal cortex, lateral and ventromedial prefrontal cortices, and anterior and posterior cingulate cortices, whereas response-focused AER strategies cause activation within the subcallosal anterior

cingulate and the cerebellum (Mauss et al., 2007a). The majority of work in this area supports these hypotheses (e.g., Dörfel et al., 2014; Frank et al., 2014; Kohn et al., 2014; Lee et al., 2012; Phillips et al., 2008). AER strategies have also been examined in ERP studies of neural activity, where AER instructions to increase or decrease emotional responses to emotional stimuli have been associated with corresponding changes in late positive potential (LPP) amplitude, an index of sustained attention to motivationally salient stimuli that is derived from parietal and occipital neural regions (areas of visuo-attentional processing) (Hajcak et al., 2010). In short, AER appears to effectively reduce both the affective and physiological effects of emotional stimuli – but also recruits brain areas underlying the AER processes. This is also consistent with the neurovisceral integration model, which proposes that neural networks are flexibly recruited to integrate central and autonomic emotional responses, with dynamic adjustments depending on the appropriate response to the specific situational context (Hagemann et al., 2003; Thayer and Lane, 2000, 2009). Along these lines, there is evidence to suggest that HRV may be an index of the integration of neural circuits that are important for guiding flexible control over behavior via autonomic regulation (Thayer et al., 2012).

### 11.3. Autonomic self-regulation under conditions of safety and danger

Under conditions of safety, the sympathetic and parasympathetic systems work together to maintain homeostasis (Wehrwein et al., 2016). On a second to second basis, via afferent signals from all body tissues, the brain is informed about the state of the body (Craig, 2003a). Based upon this information, as well as on centrally generated efferent predictions and their afferent prediction errors, the brain sends continuous signals to maintain the body’s homeostatic environment. Overall, the sympathetic system has a catabolic effect, causes the release and expending of energy and is associated with arousal, whereas the parasympathetic system has an anabolic effect, increases saving and storing of energy and is associated with rest and restoration. Sympathetic efferents to body organs – the adrenal medulla (for secretion of adrenaline/noradrenaline into the blood), the heart, smooth muscles in the lungs, intestines and other viscera, and white and brown fat and immune cells throughout the body – facilitate release of noradrenaline to enable catabolic, energy expending responses, needed to maintain body functions. For example, in the heart, activation of sympathetic efferents to the heart leads to an increase in heart rate. Parasympathetic efferents to body organs prioritize energy conservation and organ maintenance (e.g., a low heart rate and high heart rate variability), tissue regeneration and repair, down-regulation of immune and inflammatory responses, cell reproduction, and (coupled with the motor system) a body state that facilitates close emotional connection with significant others (Porges, 2011; Porges and Carter, 2011). For example, activation of parasympathetic efferents to the heart leads to a decrease in heart rate. Because of their complementary/dual roles, under homeostatic conditions the sympathetic system is conceptualized as the autonomic system accelerator and the parasympathetic system as the autonomic system brake. Working in tandem with the motor, sensory, immune-inflammatory systems and fat tissue, the sympathetic accelerator and parasympathetic brake facilitate efficient utilization of energy in life processes, a sustainable state and feelings of physical wellbeing and close emotional connections to others. To appreciate the complex anatomy of the autonomic system, how the sympathetic and parasympathetic nervous systems exert their many actions through different body systems to maintain homeostasis, and the contribution of different scientists and different theoretical viewpoints to shaping the field, see Wehrwein et al. (2016). The differential modes of parasympathetic (vagal) function in safe and dangerous contexts, their probable neural underpinnings and their relationship to the social engagement system are detailed in the Polyvagal Theory (Porges, 2011).

In response to signals of danger, the sympathetic and parasympathetic systems shift into defensive mode, putting their



complementary/dual roles aside. Danger signals (physiological, emotional or cognitive) can activate the autonomic system either bottom up (via interoceptive signals from the body) or top down (via sympathetic/parasympathetic modulating regions in the insular cortex, medial prefrontal/anterior cingulate cortices, hippocampal formation and amygdala) (Critchley et al., 2004; Gianaros et al., 2004; Strigo and Craig, 2016; Westerhaus and Loewy, 2001). Among these areas, the anterior agranular cortices may specifically issue top-down commands based on predictive coding (Barrett and Simmons, 2015; Seth and Friston, 2016). In defensive mode, the parasympathetic system withdraws homeostatic signaling. For example, withdrawal of the parasympathetic brake to the heart results in an immediate HR increase, with activation of the sympathetic system mediating additional increases in HR. Increased sympathetic outflow to the body also raises energy consumption and vascular resistance in order to prepare the body for defensive action. The parasympathetic system may now activate defensive programs – fear-induced bradycardia in the heart; nausea, vomiting, or diarrhea programs in the gut; expulsion of urine by the bladder – that work alongside the sympathetic system to defend the body from danger (Kozłowska et al., 2015; Wood et al., 1999). On the subjective level of experience, depending on the pattern of activation, the individual may experience homeostatic feelings of tension, heat, trembling, throbbing, and sweating (sympathetic activation); or queasiness, nausea, and peristaltic movements or wooziness, faintness, heaviness, and cold (defensive parasympathetic activation to the gut and heart respectively).

Release of noradrenaline in the brain results in the reconfiguration of brain networks that prioritize reflexive modes of behavior (Arnsten, 2015; Hermans et al., 2011) and coordinates integrative defensive programs by parallel activation of the autonomic efferent system, the HPA axis, the somatomotor system and the immune-inflammatory system (Janig and Habler, 2000; Westerhaus and Loewy, 2001; Wohleb et al., 2014). If the danger is sufficiently severe, the innate defense responses – hard-wired, automatically activated motor, autonomic, and sensory responses mediated by subcortical neural circuits – may also be activated. All innate programs involve an autonomic component, the pattern of activation changing according to the response activated (Kozłowska et al., 2015), which can be viewed as a form of AER. On the subjective level of experience, depending on which innate defense response is activated, the individual may experience intense feelings of fear, anger, rage, disgust, paralysis or faintness, lassitude and torpor.

#### 11.4. Homeostasis and allostasis

Chronic stress has been associated with higher risk of developing various psychopathologies that are characterized by dysregulated processing of emotional information, such as anxiety disorders, PTSD, and depression (Juster et al., 2011; Marin et al., 2011; Raymond et al., 2017; Wolf, 2008). Homeostasis refers to the organism's physiological equilibrium and its ability to maintain this internal set point. On the other hand, allostasis refers to the ability to re-establish homeostasis through change (McEwen, 1998). This means that, because of environmental demands, the set point of a physiological system can be modified by changes in other physiological systems and by behavior. For example, chronic exposure to a stressful environment could modify the 'default' emotional state of an individual. Pollack and colleagues have shown that maltreated children detected angry facial expressions more easily than control children (Pollak and Kistler, 2002). We could hypothesize that both groups of children had a similar set point prior to maltreatment exposure. Given that the environment of the maltreated children was characterized by exposure to chronic stressors, the organism needed to adapt to maximize survival likelihood. Having a more refined and rapid ability to detect emotionally-charged information (i.e., angry faces) might carry an advantage for maltreated children. Therefore, through an allostatic process, the initial set point of emotion detection has been modified to adapt to the environment. This is just

one example where 'modified cognitive processes' serve adaptive purposes. In the same vein, it has been shown that maltreated children have higher amygdala volume (Lupien et al., 2011; Tottenham et al., 2010). Given the role of the amygdala in emotion processing, this could be an adaptive change to better deal with the environmental demands. Allostatic processes that can change afferent interoceptive information thus provide automatic emotion regulation to the extent that this information is either itself subjectively perceived as feelings, or it influences central circuits subserving experienced or predicted feelings and emotions. In the short term, these modifications are usually beneficial to physiological and emotional wellbeing. However, many allostatic processes, when maintained over long periods, can add to what is termed "allostatic load" which reflects the sum total of demands, energetic and otherwise, required to maintain homeostasis by compensatory mechanisms (McEwen, 1998; McEwen and Wingfield, 2003). High levels of allostatic load can degrade the physiological substrates of interoceptively perceived wellness and negatively impact feelings and emotion.

#### 11.5. Emotion regulation across the lifespan

Over the course of development, the processing of emotional experience changes with corresponding developmental changes in neural circuits and CNS organization. Thus at different ages, individuals differ in both emotional reactivity and in their ability to regulate emotion (Goldsmith et al., 2008). At each stage in the development of emotion regulatory capacity across the lifespan, interoception provides critical feedback as to the success of different regulation strategies. For example, in infancy, before cognitive development can support deliberative emotion regulation, interoception of reductions in physiological discomfort teaches the infant which behaviors are effective at self-soothing via negative reinforcement.

During early infancy, rudimentary forebrain inhibitory centers begin to emerge, which alters behavioral and emotional changes in response to the environment (Thompson, 1991). Early characteristics of temperament, such as negative affect, also impact early emotion regulation processes (Calkins et al., 2002). For example, easily frustrated infants have higher RSA than less easily frustrated infants, which may reflect their greater level of emotional reactivity (Calkins et al., 2002). This finding is critical in the developmental perspective of emotion regulation because the ability to manage distress and anger when frustrated is critical for later adaptation, including the development of self-control and social competence during childhood (Calkins et al., 2002).

Self-regulatory abilities develop in tandem with the prefrontal cortex (PFC) during childhood (Pitskel et al., 2011). This developmental process was highlighted by Levesque et al. (2004) who found that greater prefrontal activation in children relative to adults during the voluntary self-regulation of sadness may be related to the immaturity of the prefronto-limbic connections in childhood. Relatedly, Lewis et al. (2006) suggested that inhibitory processes recruited for emotion regulation involve differing cortical regions as children mature. Lastly, with regards to emotion regulation strategies, children become better able to successfully regulate emotional responses utilizing pretense as a cognitive reappraisal strategy, suggesting that the ventromedial PFC attenuates amygdala and insula activation during the down-regulation of emotion (Pitskel et al., 2011).

During the transition from childhood to adolescence, hormonal changes and rapid brain development occur with the onset of puberty, and socioemotional processes become more salient, as adolescents begin to spend increased time with peers. On a physiological level, the transition to adolescence is associated with greater subcortical reactivity to affective facial displays, which may be associated with successful regulation of emotional responses to one's environment and may contribute to adaptive adolescent interpersonal functioning (Pfeifer et al., 2011). The continuing development of the autonomic nervous system and associated emotional processing abilities also contribute to

enhanced emotion regulation ability during adolescence. Higher vagally-mediated heart rate variability has demonstrated a strong association with external emotion regulation strategies, such as support seeking, which are essential to the growth of the socioemotional processes that are simultaneously being developed during adolescence (De Witte et al., 2016).

The most widely studied emotion regulation strategies in young adults are internal emotion regulation strategies, namely cognitive reappraisal and suppression. Previous research suggests that individuals with normative development shift emotion regulation strategies from the use of suppression to increased use of cognitive reappraisal as they move into adulthood (John and Gross, 2004). Physiologically, the use of suppression results in increased sympathetic activation in response to an emotional event, whereas cognitive reappraisal does not produce this effect (Gross, 1998a). As individuals age, this shift from the use of suppression to cognitive reappraisal is physiologically beneficial, as the physiological processes involved in suppression – particularly the sustained sympathetic arousal – are physically demanding on the body and could potentially have adverse long-term ramifications (Goldin et al., 2008).

In older adults, extant emotion regulation literature suggests individuals develop a positivity bias as they age, which aids in creating emotional stability. According to socioemotional selectivity theory, as time horizons become shorter older adults reduce their number of social contacts. This process is referred to as “social pruning,” which allows older adults to maintain their closest, and most emotionally fulfilling relationships, while removing less important relationships (Carstensen et al., 2003). Additionally, socioemotional theory suggests that these shifts in time perspectives also lead to changes in cognitive processing of emotional information, including decreased memory for negative images (Charles et al., 2003) and increased attentional bias for faces expressing positive emotions (Mather and Carstensen, 2003).

Results from electrophysiological studies provide support for the socioemotional selectivity theory's cognitive processing explanation of the positivity bias, however, with different paths. Findings are mixed, with some studies showing older adults have larger LPP amplitudes in response to positive images only, and others showing a decrease in LPP amplitudes for negative images, but no increase in LPP amplitudes for positive images (Kisley et al., 2007; Meng et al., 2015). Deployment of attention appears to be an important component of the positivity bias in older adults, though results remain mixed in regards to whether there is a decrease in attention and reactivity to negative stimuli only, or if there is also a simultaneous increase in attention and reactivity to positive stimuli that concurrently work to produce the positivity bias in older adults.

#### 11.6. Physiological processes in dyadic relationships

Within close relationships, an individual's emotions are connected to and affected by their partner's emotions. Given that the ANS is related to emotional expression and regulation and is implicated in social interaction, it may provide a platform for dyadic influence on emotion (Butler and Randall, 2013; Porges, 2009). Indeed, a growing body of research suggests that interdependencies develop between the physiologic responses of close relationship partners through social interaction (see Palumbo et al., 2017 for review). Throughout the lifespan, physiologic linkages between partners are thought to provide a foundation for connections between individuals who can aid in basic needs (Sbarra and Hazan, 2008). There are several terms used in the literature to describe physiologic linkage between partners such as “synchrony,” “contagion,” and “coregulation.” The strength and frequency of physiologic linkages across partners are not fundamentally good or bad; rather the consequence depends on the context and the emotions involved (Butler, 2011). Changes in one partner's physiology may lead to increases or decreases in the other's physiology to promote regulation and stability or result in dysregulation (Butler and Randall, 2013; Helm

et al., 2014).

Physiologic linkages develop between an infant and primary attachment figure during social contact (Feldman, 2012). Over time, the attachment figure scaffolds the infant's emerging emotion regulation capacity (Gianino and Tronick, 1988). Studies have shown that infant synchrony with an attachment figure predicted self-regulation and behavioral adaptation during childhood and capacity for empathy in adolescence (Feldman, 2007a,b). Later in life within parent–child and adult romantic relationships, the degree and direction of physiologic linkage between partners has been associated with relationship satisfaction and individual psychopathology. For example, one study showed that 60% of the variance in marital dissatisfaction was accounted for by stronger physiologic linkage between partners during conflict (Levenson and Gottman, 1983). Another study of mother–daughter pairs showed that dyads' physiologic responses during a positive interaction were negatively correlated for dyads in which both mother and daughter had histories of depression and positively correlated for dyads without histories of depression (Amole et al., 2017). Although this area of research is relatively new, preliminary work shows progress toward understanding the powerful influences of dyadic relationships on physiology and emotion.

Achievement of developmental milestones of emotional regulation in infancy, such as self-soothing, rely upon the child's use of interoception to track changes in bodily sensations and discover their ability to influence these sensations deliberately or via automatic processes such as negative reinforcement. Physiological coupling may speed this process by allowing a parent's physiological responses to “instruct” those of the child. The next section will examine the phylogenetically ancient forms of AER that are likely to be implicitly recruited very early in life.

#### 11.7. Extinction and habituation

An important element of emotion regulation is emotional memory and its selective consolidation based upon valence, temperament, biases, expectations and variations in individuals' psychological needs and issues. In addition to emotion regulatory strategies requiring higher-level forms of cognition (e.g., reappraisal), emotional extremes in humans are moderated by universal mammalian learning and memory processes such as habituation and extinction – phylogenetically primitive forms non-associative and associative memory respectively that function to down-regulate fear and anxiety. Such processes, subserved by midline paralimbic circuitry, may in turn be recruited by more advanced cognitive processes supported by lateral prefrontal areas (Delgado et al., 2008). As such, these processes may represent the most basic forms of emotion regulation in the animal kingdom. In habituation, behavioral and physiological responses during initial exposure to a stimulus diminish with repeated presentations of that stimulus (Grissom and Bhatnagar, 2009; Leussis and Bolivar, 2006; Thompson and Spencer, 1966). In extinction, an organism learns that stimuli that once signaled danger no longer do so (Hermans et al., 2006; Quirk and Mueller, 2008). Both processes are adaptive in that they free up limited energetic resources to confront new dangers or opportunities. Additionally both processes result in neuroplastic changes that can become memories if they are consolidated and later retrieved. Rather than erasing a previously established association of a stimulus with danger, extinction represents formation of a new memory that competitively inhibits the previously established fear memory. In both human and non-human mammals, fear and anxiety produce marked physiological manifestations (such as activation of the sympathetic nervous system) and behavioral signs (such as freezing) that diminish as habituation and extinction moderate such fears. Although clearly demonstrated in experimental (e.g., fear conditioning) or psychotherapeutic (e.g., exposure therapy) settings, it is important to recognize that habituation and extinction are processes that are ongoing in the course of everyday life. For example, individuals who display resilience

and recovery, without any therapeutic intervention, following a psychologically traumatic event, acquire extinction memories based upon spontaneous encounters with reminders of the trauma (Pace-Schott et al., 2015b).

The next section considers the role of sleep in emotion regulation. Notably, important changes in sleep and circadian rhythms occur at similar ages and developmental stages as changes in emotion regulation. For example, across the first year of life, the basic sleep stages and circadian rhythms, as well as the transition to more consolidated nocturnal sleep, develop and these are believed to reflect the extensive synaptic genesis, pruning and circuit formation occurring during this time (Davis et al., 2004). Similarly, in early adolescence, there is a marked phase delay in sleep timing along with the beginning of a steep decline in slow wave sleep (SWS) that may reflect the resumption of synaptic pruning, myelination and hormonal changes (Crowley et al., 2007). Across late adolescence and early adulthood the continued decline in SWS may accompany the increasing myelination of frontal regions (Kurth et al., 2010). Lastly, the greatly diminished proportion of SWS, phase advance in sleep timing, and apparent decline in sleep need accompany the neural changes of aging (Skeldon et al., 2016).

### 11.8. Sleep and emotion regulation

It is often hypothesized that sleep and dreaming play an emotion regulatory role in healthy humans (Cartwright et al., 1998; Nielsen and Levin, 2007; Walker and van der Helm, 2009). Such regulation may become disrupted in mood and anxiety disorders and, conversely, sleep disruption is increasingly seen as a contributor to the development of such disorders (reviewed in Pace-Schott et al., 2015b). As previously noted, an important element of human emotional regulation is the selective encoding, consolidation and retrieval of emotional memory. Sleep promotes memory consolidation in many domains (Rasch and Born, 2013) and has consistently been shown to enhance consolidation of emotional memory albeit with mixed findings as to whether sleep preferentially augments emotional over neutral memories (reviewed in Goldstein and Walker, 2014; Hutchison and Rathore, 2015; Kahn et al., 2013; Pace-Schott, 2015; Palmer and Alfano, 2016; Tempesta et al., 2017). For example, a night's sleep promotes consolidation and generalization of both habituation and extinction, and paralimbic circuits controlling learning and memory of both fear and extinction overlap with midline areas selectively activated in REM (Pace-Schott et al., 2015a).

A night of sleep profoundly affects our emotional state and, in most cases, will improve mood along with other subjective experiences of mind-body wellness such as restedness, alertness and stamina. In part, improved mood is to be expected from the 2-process model (Borbely, 1982) whereby sleep propensity results from an interaction between sleep-homeostatic (Process S) and circadian (Process C) factors. Regarding Process S, sleep dissipates endogenous somnogens – substances believed to accumulate in proportion to time spent awake. Adenosine is the strongest candidate for such a substance (Porkka-Heiskanen and Kalinchuk, 2011) but multiple cytokines may also play roles (Davis and Krueger, 2012) especially when the immune system is challenged (Haack et al., 2009b). Because endogenous somnogens promote drowsiness, their dissipation would be alerting. Hormonal rhythms that are under circadian control (Process C) such as the pre-awakening rise in cortisol (Kalsbeek et al., 2012) and the associated cortisol awakening response (Federenko et al., 2004), as well as, in men, a testosterone morning acrophase (Diver et al., 2003), are believed to prepare us for the challenges of the new day and could be expected to promote a sense of vigor upon waking. The abrupt change from a nadir of monoaminergic (serotonergic, noradrenergic and histaminergic) neuromodulation during REM sleep (abundant during the late sleep period) to wakefulness, at which time they return to waking levels (Pace-Schott and Hobson, 2002), may further promote a sense of renewed vigor. Moreover, unlike cortisol itself, corticotropin releasing factor (CRF),

which acts centrally as an anxiogenic neurochemical (Heinrichs and Koob, 2004), shows an evening acrophase and morning nadir in cerebrospinal fluid (Kling et al., 1994).

Physiologically restorative functions of sleep, such as the homeostatic equilibration of stress, reward, autonomic and neuroendocrine systems, may play a key role in sleep's emotion regulatory effects. Close, bidirectional coupling between sleep states and the autonomic nervous system is suggested by the marked increase in parasympathetic outflow during NREM, especially its deepest stage, SWS (de Zambotti et al., 2018). The selective secretion of growth hormone at this same time (Sassin et al., 1969) as well as the circadian nadir of plasma cortisol (Kalsbeek et al., 2012) similarly suggests that SWS favors restorative, anabolic processes. Other restorative processes linked to SWS include restoration of synaptic homeostasis via downscaling of excess potentiation generated during waking (Tononi and Cirelli, 2006) as well as physical removal of metabolic wastes via the brain's glymphatic system (Jessen et al., 2015). REM sleep may also serve physiologically restorative functions. It has been suggested that the nadir of monoaminergic neurotransmission in REM may serve to restore receptor sensitivity and, thus, the alerting effects of these neuromodulators might be especially strong following nocturnal sleep (Rotenberg, 2006). Alternatively, stress-related elevations of norepinephrine may be reduced by sleep, especially during REM, thereby promoting the subjective experience of greater wellbeing upon awakening (Faraut et al., 2015b).

In addition to direct effects on limbic circuitry, sleep-dependent processes may regulate emotion by promoting homeostasis in physiological processes sensed, during subsequent wakefulness, via our interoceptive capacities (Craig, 2003a; Strigo and Craig, 2016). Such processes include a remarkable number of physiological parameters that are innervated in such a way that suggests they might contribute, via interoception, to the spectrum of subjective feelings of wellbeing. These include not only pain and temperature receptors but also metaboreceptors, hormone receptors, osmoreceptors, etc. (Craig, 2002). Whereas some of these interoceptive inputs affect emotion indirectly or below the level of consciousness (Craig, 2002), the experience of pain eventually enters conscious awareness (Borsook et al., 2018), can strongly influence mood and emotion (Lumley et al., 2011; Minami and Ide, 2015; Mollet and Harrison, 2006), and is strongly modulated by sleep amount and quality (Haack and Mullington, 2005; Haack et al., 2009b).

Pro-inflammatory cytokines may contribute to such pain and discomfort (see Section 9) and their elevation is associated with both sleep disruption (Irwin et al., 2016) and circadian misalignment (Wright et al., 2015). Notably, prostaglandins (PGs), interleukin-6 (IL-6) and tumor necrosis factor alpha (TNF $\alpha$ ) have all been associated with increased spontaneous pain symptoms following both sleep deprivation and sleep restriction (Haack et al., 2007, 2009a,b; Haack and Mullington, 2005).

Numerous studies have shown that elevation of both spontaneous and evoked pain – hyperalgesia – is promoted by the sleep-deprived state (Finan et al., 2013; Haack et al., 2009b; Kundermann et al., 2004; Lautenbacher et al., 2006). Specifically, sleep deprivation may interfere with descending opioidergic, serotonergic and dopaminergic brainstem pain-modulating pathways and thus may underlie the hyperalgesia produced by experimental sleep deprivation, as well as the bidirectional exacerbation of sleep disturbance and pain in conditions such as fibromyalgia (Choy, 2015; Haack et al., 2009b; Smith et al., 2007). Notably, napping has been shown to reverse hyperalgesia induced by sleep restriction (Faraut et al., 2015a), possibly via reductions in proinflammatory cytokines such as IL-6 (Faraut et al., 2015b). The downregulation of proinflammatory cytokines by sleep may also prevent mood disorders as increasing evidence points to elevated levels of C-reactive protein (CRP) as well as IL-6 and TNF $\alpha$  in major depressive disorder (Haapakoski et al., 2015).

Forebrain structures involved in both interoception and mood also



show evidence of sleep-dependent modulation, the most striking being the REM-associated selective activation of anterior midline limbic and paralimbic structures that include areas involved in emotion and emotion regulation such as the amygdala and vmPFC (Nofzinger et al., 2004; Pace-Schott and Picchioni, 2017). This selective activation might regulate emotion via memory consolidation (Pace-Schott et al., 2015a), active processes taking place during dreaming (Nielsen and Levin, 2007), depotentiation of emotional components of memory (Walker and van der Helm, 2009) as well as yet to be discovered mechanisms. A prominent part of this REM-activated area is the insular cortex (Braun et al., 1997; Nofzinger et al., 1997), a region believed to play a key role in processing interoceptive information (Craig, 2002, 2009, 2011; Namkung et al., 2017).

Less well-researched influences on emotion closely related to sleep involve circadian rhythms. These include variation in individuals' endogenous circadian phase (controlled by the molecular clocks in the suprachiasmatic nucleus) that is normally entrained to ambient light-dark cycles. For example, "morningness-eveningness" – the degree to which an individual favors early or late times of day to engage in wake-related activities – reflects internal physiological rhythms, best indexed by the rise in plasma melatonin proximal to bedtime (Adan et al., 2012). Those with more pronounced evening preference (evening types) show greater tendency toward neuroticism and greater risk for anxiety and mood disorders (Adan et al., 2012). In addition, circadian influences have been detected on positive affect (Murray et al., 2002), reward motivation (Murray et al., 2009), sympathetic reactivity (Hot et al., 2005) and extinction (Pace-Schott et al., 2013). The sensitivity of human emotion to the environmental light-dark cycle is powerfully illustrated by persons with seasonal affective disorder (Levitin, 2007; Magnusson and Boivin, 2003). Recent work on circadian factors influencing risk of affective disorders have revealed extensive interactions between key emotion regulatory neurotransmitters such as dopamine and the genes controlling the molecular circadian clock (McClung, 2007, 2011, 2013). Moreover, light itself has been demonstrated to exert subtle influences on emotion mediated by the recently discovered intrinsically photosensitive retinal ganglion cells expressing the photopigment melanopsin (LeGates et al., 2012; LeGates et al., 2014). Peripheral physiological systems also express circadian rhythmicity and their misalignment with the environment (e.g., from jetlag) can result in interoceptively sensed discomfort (e.g., gastrointestinal) that can, in turn, negatively affect emotion (LeGates et al., 2014).

Abnormally high interoceptive sensitivity may underlie some of the sleep difficulties in persons with insomnia (Ewing et al., 2017; Wei et al., 2016). For example, compared with non-insomniac controls, individuals with Insomnia Disorder showed larger cortical evoked responses to their own heartbeat (Wei et al., 2016). Similarly, among individuals with mood and anxiety disorders, poorer sleep quality was associated with greater confidence in cardiac interoceptive sensitivity (heartbeat detection) despite their objective interoceptive accuracy showing the opposite relationship (Ewing et al., 2017). A recent fMRI study examining human fear conditioning and extinction in primary insomnia showed a delayed down-regulation of insula responses to extinguished conditioned stimuli (Seo et al., 2018).

Much of the literature reviewed in this and other sections suggests that the integrity and maintenance of homeostasis, not only in the CNS and PNS but in all systems of the body (e.g., metabolic, cardiovascular, immune), contributes to interoceptive feelings, moods and even to consciously identified emotions. The integrated output of all these systems may constitute an important, albeit highly complex, physiological input to a central mechanism of emotional homeostasis that can be facilitated or perturbed by a wide variety of changes in other homeostatic systems. And sleep contributes to homeostasis in many of these systems. We will next consider a few of the numerous neuropsychiatric conditions in which relationships between physiology and emotion are disordered and such abnormalities may be experienced via interoception.

## 12. Disorders of the relationship between physiology and emotion

### 12.1. Somatization

Ending in "viscerosensory" regions such as the insula, the interoceptive network supports the "bottom-up" generation of many body sensations, for example, itching, pain, and thirst (Craig, 2009, 2011; Damasio and Carvalho, 2013; Di Lernia et al., 2016). Guided by interoception, "visceromotor" structures, such as the subgenual anterior cingulate cortex, can then modulate these body sensations and initiate behaviors to restore homeostasis. Additionally such structures may be able to predict and generate interoceptive feelings as well as homeostatic changes in a "top-down" manner based upon prior experience (Barrett and Simmons, 2015). Such modulation of interoceptive sensations is of fundamental survival value in guiding humans away from threats and toward rewards (Craig, 2011; Damasio, 1996). Overt threats or opportunities prompt physical sensations that may become conscious, be expressed verbally as feeling and emotions and provide additional flexibility of responses to ensure organismic integrity.

Many believe chronic pain problems (pain with little or no basis in tissue damage; Smith and Dwamena, 2007) can be explained by alterations in the top-down influences on the interoceptive network (Craig, 2003b; Di Lernia et al., 2016; Tabor et al., 2017) or on heightened sensitivity to afferent interoceptive signaling (Krautwurst et al., 2014; Krautwurst et al., 2016). While humans are hard-wired to some extent, much emotional expression, including pain, is socially constructed and begins in childhood (Barrett, 2017a). Children who become chronic pain patients often have experienced deviations from the normal construction of pain experiences. For example, they may have received attention only when having pain, others may have associated the pain of early abuse (which is very prevalent; Fiddler et al., 2004) with otherwise unavailable attention, and others may have seen members of the family attended to only with physical symptoms.

This undue physical focus on pain interrupts the child's normal transition from the physical expression of emotions in infancy to the healthier verbal expression of emotions and feelings when language develops (Schore, 2003). This impairment of normal psychological growth and development is sometimes called alexithymia (an absence of language for emotional states) (Levenson, 2005) or somatosensory amplification (Koteles and Witthoft, 2017). Although certainly maladaptive in society, chronic pain patients are acting to offset perceived threats to body integrity.

The greater the number and severity of pain symptoms, the more likely depression and anxiety will co-occur and, unfortunately, enhance pain perception (Kroenke, 2003). Of little or no value in chronic pain (CDC, 2016), opioids often are prescribed and further magnify the pain by aggravating depression and/or by inducing opiate hyperalgesia, the latter a paradoxical worsening of pain resulting from narcotics (Servick, 2016). Undergirding the chronicity is that chronic pain and attendant psychosocial distress can change the structure of the brain's widespread cognitive and affective structures in ways that perpetuate pain perception (Latremoliere and Woolf, 2009).

Treatment emphasizing the physician-patient relationship, motivational interviewing, cognitive-behavioral principles, and antidepressants has been shown effective at reducing medically unexplained pain (Smith et al., 2003, 2009, 2014).

### 12.2. Neurological syndromes

Any neurological disease that directly or indirectly affects the limbic system will induce emotional disturbances. For instance, patients who sustained frontal brain lesions can present spasmodic laughs and cries, while others can demonstrate gelastic or dacrystic seizures due to a lesion in the hypothalamus. Patients with Parkinson's disease, syndromes of dementia and with multiple sclerosis also present emotional disorders including depression, anxiety, anger, euphoria and



uncontrollable outbursts of crying or laughing (Rao et al., 1992).

Conversely, emotion can be hard to evaluate in patients with other neurological deficits. Patients with locked-in syndrome are unable to move and speak due the disruption of the cortico-spinal and corticobulbar pathways, and the only way of communication is through eye movements (Bruno et al., 2015). Despite the fact that this syndrome is probably seen as one of the most scary of conditions, the majority of chronic patients report a good quality of life (Bruno et al., 2015). Akinetic mutism is another disorder defined as a total absence of spontaneous behavior and speech with low emotional display in the presence of preserved visual tracking (Marin and Wilkosz, 2005).

### 12.3. Sleep disorders

The sleep disorders offer insight into how dissociation between arousal and consciousness may interact with the physiological substrate of emotion (Mahowald et al., 2011). Three specific disorders may be particularly instructive.

In Restless Leg Syndrome (RLS), an individual experiences unpleasant sensations, typically in the legs and emerging typically the evening and intensifying while attempting sleep. One theory attributes RLS sensations to deficient signaling from a small hypothalamic dopaminergic nucleus (A11) whose normal function is to facilitate inhibitory control of dorsal horn sensory neurons in the spinal cord (Clemens et al., 2006). The resulting imbalance of excitatory input and its inhibitory control may result a “focal akathisia” whereby normal baseline, tonic sensory input from skeletal musculature is disinhibited and thus perceived centrally as unpleasant afferent sensation.

Among emotional parasomnias, nightmares are typically not accompanied by extreme autonomic activation (Nielsen and Carr, 2017). In contrast, in night terrors, intense autonomic activation arises in the absence of a conscious precipitant or appraisal (Fisher et al., 1970, 1973). Nightmare disorder thus represents centrally generated emotional experience without peripheral input whereas night terror represents autonomically generated emotion in the absence of cognitive awareness. Interestingly, increased autonomic activation emerges in more severe trauma-related nightmares that are accompanied disruptive behavior suggestive of REM-sleep Behavior Disorder (RBD) (Mysliwiec et al., 2018).

In RBD, dreamed behavior and emotions are enacted due to loss of REM atonia. RBD dreams appear to contain abnormally high levels of aggression (Fantini et al., 2005; but see D’Agostino et al., 2012; Oudiette et al., 2009). Disinhibition of subcortical instinctual motor generators (due to underlying synucleinopathy) may contribute to elevated aggression. Excessive movements resulting from such disinhibition might, in turn, heighten dream emotion due to efferent copy sensory feedback to cortical regions elaborating dream content (Blumberg and Plumeau, 2015). Interestingly, individuals with RBD often show prominent autonomic dysfunction (Chiaro et al., 2017; Ferini-Strambi et al., 2014; Frauscher et al., 2012; Miglis et al., 2017).

### 12.4. Psychophysiological indices as markers of emotion dysfunction in psychiatric disorders

Psychophysiological indices have been widely used to probe emotional functioning across a variety of psychiatric populations, including depression, anxiety, substance use disorders, and schizophrenia. A wide variety of indices have been used in this regard, including cardiovascular psychophysiology, peripheral physiology (e.g., skin conductance), startle reflex, pupillometry, and electrophysiology (e.g., EEG, ERPs, MEG). These measures have the advantage of providing a more objective measure of emotional responses relative to self-report measures and can also be used to help elucidate the sequence of emotional responses at various levels of temporal resolution. Here we highlight some examples of ways in which psychophysiology can highlight alterations in emotional functioning in psychiatric disorders, with a focus

on depression and PTSD.

#### 12.4.1. Depression

Abnormalities in autonomic nervous system functioning have been associated with depression. For example, major depressive disorder (MDD) in adults has been repeatedly associated with low resting parasympathetic nervous system activity, as indexed by resting levels of RSA (Kemp et al., 2010; Kikuchi et al., 2009; Rottenberg et al., 2007; Udupa et al., 2007), although these findings have not always been consistent (e.g., Licht et al., 2008; Lehofer et al., 1997; Yeragani et al., 1991). More consistent findings have been observed for RSA reactivity in response to laboratory tasks, with depressed adults exhibiting blunted RSA withdrawal to psychological stressors, such as a speech task (Bylsma et al., 2014; Rottenberg et al., 2007), as well as physical challenges, such as a handgrip task (Nugent et al., 2011). To a lesser extent, abnormalities in sympathetic nervous system (SNS) activity have also been observed in MDD. For example, Salomon et al. (2009, 2013) found blunted sympathetic nervous system reactivity as indexed by lengthened pre-ejection period (PEP) to a laboratory speech stressor task, although others have also found shorter PEP in individuals with depressive symptoms (Light et al., 1998). Overall, research thus far has demonstrated mixed evidence of parasympathetic and sympathetic deficits in depression. Low resting RSA and blunted RSA reactivity are thought to reflect poor self-regulation (Balzarotti et al., 2017).

The majority of depression research has focused almost exclusively on individual parasympathetic or sympathetic indices. However, consideration of the dynamic interplay between sympathetic and parasympathetic regulation may be critically important for providing a comprehensive understanding of behavioral and affective reactivity and regulation (Berntson et al., 1991; Sunagawa et al., 1998). For example, Bylsma et al. (2015) examined changes in cardiac autonomic balance (CAB; Berntson et al., 2008) in response to psychological challenges in youth with a history of juvenile-onset-depression and healthy controls and found that while controls showed an expected shift from sympathetic relative to parasympathetic activation in response to the stressors, youth with a history of depression showed the opposite pattern. Elsewhere, it has been found that atypical patterns of resting RSA and RSA reactivity in youths with a history of juvenile-onset depression predicted deficits in mood repair as assessed by both trait measures and laboratory probes (Yaroslavsky et al., 2016). In addition, other work has found that specific combinations of resting RSA and RSA reactivity moderate the depressogenic effect of maladaptive mood repair (Yaroslavsky et al., 2013).

Not surprisingly, ERP indices of affective processing have also been associated with depression and depression risk. For example, depressed adults show less of an increase in LPP amplitude to threatening faces (Foti et al., 2011), suggesting that they are more sensitive to threatening stimuli. High familial risk children (with at least one depressed parent) also show a similar blunting in their LPP response to emotional faces (Kujawa et al., 2012). Further, adults with both current and remitted MDD have shown aberrant LPP changes following reappraisal (Bylsma, 2012). The LPP has also been found to be associated with depressive symptoms and maladaptive emotion regulation strategies in healthy children (Dennis et al., 2009). Adults with current and remitted depression (e.g., Foti and Hajcak, 2009), high risk older adolescents (Foti et al., 2011), and younger youth (ages 8–13) with depressive symptoms (Bress et al., 2012), have exhibited reduced FN amplitude in response to monetary rewards and performance feedback, indicating a reduced response to reward. The FN has also been found to prospectively predict onset of MDD in adolescent girls (Bress et al., 2013). These findings suggest that ERP indices may be useful neural markers of alterations in emotional processing associated with depression.

Abnormalities in interoception occur in depression. These have been linked to negatively biased predictive coding that results in afferent interoceptive information being interpreted in a manner consonant with depressive beliefs (Paulus and Stein, 2010). A similarly Bayesian

proposal suggests that top-down control of physiological states by active prediction, and the modification of these internal models by interoceptively sensed prediction errors is inefficient and energetically costly in the depressed state (Barrett et al., 2016). Another perspective combines the multiple abnormalities of autonomic, neuroendocrine and immune function with abnormalities of interoceptive brain structures into a general Interoceptive Dysfunction model of depression (Harshaw, 2015). Although full consideration of abnormal interoception in depression is beyond the scope of this review, the plethora of somatic symptoms makes it clear that the interoceptive sense of self, along with self-referent cognitions becomes distorted and negatively biased in depression.

Another factor in understanding how physiological indices are altered in depression is the impact of anxiety or the experience of traumatic stress, as depression and anxiety have high rates of co-morbidity and depressed individuals are more likely to have experienced traumatic stress. Anxiety and traumatic stress are also associated with alterations in physiological responses.

#### 12.4.2. Trauma and stress related disorders

Physiological disturbances are hallmarks of trauma-, fear-, and anxiety disorders. One of the key features of Post Traumatic Stress Disorder (PTSD) is heightened emotional and physiological reactivity to reminders of traumatic events that occurred in the past. Therefore, measuring physiological responses such as changes in heart rate (HR), skin conductance (SC), and startle response when presented with trauma-related stimuli offers the potential for objective assessment of PTSD symptoms (Jovanovic et al., 2017; Orr et al., 2002; Pole, 2007). One of the earliest psychophysiological methods used a script-driven imagery procedure, in which a traumatic event is transcribed and played back to the patient while physiological reactivity is measured (Lang, 1978; Pitman et al., 1987). Among trauma survivors, those with PTSD exhibit a stronger HR and SC response to trauma scripts than those without PTSD (Orr et al., 1997; Pitman et al., 1987; Shalev et al., 1993). A recent meta-analysis of earlier studies (Pineles et al., 2013) confirmed that psychophysiological responses to trauma scripts were predictive of PTSD diagnosis and were stable across time (Bauer et al., 2013). In recent studies, virtual reality (VR) has been used as a platform to present trauma stimuli, providing a more immersive environment. A study of active duty soldiers observed increased HR responses to VR scenes in those with PTSD symptoms relative to non-symptomatic soldiers (Costanzo et al., 2014). With the advancement of smartphone and similar devices, SC or HR can be recorded continuously during a trauma reminder using mobile applications. These new technological advances allow for low-burden measures of psychophysiology without need for specialized training (Hinrichs et al., 2017).

Startle responses can be measured using electromyograph (EMG) recordings of the eyeblink muscle contraction in response to loud sounds. Such startle responses can then be modulated by emotional contexts (Davis, 1992; Lang et al., 2000). For example, startle can be reliably used as a measure of fear conditioned responses in humans (Jovanovic et al., 2005). Studies in PTSD have shown that fear-potentiated startle can be dysregulated in PTSD (Jovanovic et al., 2010; Pole et al., 2003), as well as panic and other anxiety disorders (Duits et al., 2015; Lissek et al., 2008). Accompanying replicated measures of physiological hyperarousal, patients with PTSD show elevated scores on the Anxiety Sensitivity Index (Peterson and Reiss, 1987) a self-report questionnaire assessing fear of sensations associated with physiological arousal (Wald and Taylor, 2008). Additionally, in such patients, interoceptive exposure therapy can precipitate trauma memories (Wald and Taylor, 2008).

#### 12.4.3. Interoception in other psychiatric disorders

The above examples are representative, but by no means exhaust the range of neuropsychiatric as well as general medical conditions in which a peripheral or central physiological abnormality manifests as

emotional dysregulation and interoceptive abnormalities (Khalsa et al., 2018). Heightened interoceptive sensitivity has been widely documented in patients with panic disorder who show augmented interoceptive sensitivity whether measured by the ASI or by heartbeat detection tests (Domschke et al., 2010; Limmer et al., 2015; Yoris et al., 2015). Moreover, interoceptive conditioning is implicated in the etiology of panic disorder (De Cort et al., 2017) and interoceptive exposure therapy is employed in its treatment (Boettcher et al., 2016). Interoceptive feelings are the primary positive and negative reinforcers perpetuating substance use disorders (Paulus and Stewart, 2014). Interoceptive abnormalities are noted in psychoses (Brosey and Woodward, 2017), obsessive-compulsive disorders (Yoris et al., 2017) and eating disorders (Jenkinson et al., 2018). Heightened interoceptive sensitivity may also characterize the euphoric manic state or the emotional lability of borderline personality disorder. In contrast, disconnection from interoceptive feelings may occur in autism spectrum disorders (Quattrocki and Friston, 2014) and with the anhedonia accompanying many neuropsychiatric disorders (Harshaw, 2015). Yet different forms of interoceptive disconnection may contribute to the lack of empathy in antisocial personality disorder (Nentjes et al., 2013), in experiences of dissociation and depersonalization and in states of delirium or prefrontal trauma. It has even been suggested that impaired interoception may be an endophenotype predisposing individuals to a wide variety of psychopathology (Murphy et al., 2017). And deficits at the level of interoceptive predictions and processing of prediction error has similarly been proposed to underlie many neuropsychiatric symptoms (Khalsa et al., 2018; Seth and Friston, 2016).

### 13. A linguistic approach

#### 13.1. An expanded definition of “feeling” and “emotion”

With this understanding of the current state of research related to physiology and emotions as a backdrop, our team was specifically tasked to review the language that people use to express feelings related to physiological processes. Within the realm of affective research, confusion arises over the fact that some feelings are a component/constituent of emotional responses. For example, fear as an emotion consists of a continuum of automatically activated defense behaviors (Kozłowska et al., 2015) that co-occur along with “feelings of fear”. Consequently, the term feeling is often used incorrectly as a synonym for emotion and vice versa (LeDoux, 2015; Munezero et al., 2014). But feelings are not emotions per se (LeDoux, 2015) which tend to be more complex (Fontaine et al., 2007), and feelings are not limited to those that co-occur with specific emotions. Rather, feelings encompass a wide range of important mental experiences such as those signifying physiological need (e.g., hunger), tissue injury (e.g., pain), general level of functioning (e.g., well-being) or the dynamics of social interactions (e.g., gratitude) (Damasio and Carvalho, 2013). Additional challenges relate to the fact that feelings are not consistently defined, and that our definitions for these terms can evolve over time (Tissari, 2016). Moreover, while some feelings may be universally experienced across cultures (e.g., hunger, pain, cold, fatigue, etc.), other feelings are understood to be culturally constructed such as gratitude (Boiger and Mesquita, 2012) and optimism (Joshi and Carter, 2013).

As a result, the Human Affectome Project taskforce agreed that any attempt to create a linguistic inventory of articulated feelings would need to first define feelings in a manner that can help us understand the full range of terms to be considered. Such an analysis must then be undertaken with an acute awareness that variations in terminology are going to exist in day-to-day usage, between languages, and across cultures. So, a definition for feelings was developed as part of the project. A small task team within the larger effort reviewed the literature to create a definition for feelings that could serve as a starting point. The task team produced a first draft and shared it with the entire taskforce of nearly 200 researchers, feedback/input was gathered, and then it

was refined, redistributed and the process iterated several times to achieve broad consensus within the group. The resulting definition is as follows.

A “feeling” is a fundamental construct in the behavioral and neurobiological sciences encompassing a wide range of mental processes and individual experiences, many of which relate to homeostatic aspects of survival and life regulation (Buck, 1985; Damasio and Carvalho, 2013; LeDoux, 2012; Panksepp, 2010; Strigo and Craig, 2016). Feeling is a perception/appraisal or mental representation that emerges from physiological/bodily states (Damasio and Carvalho, 2013; LeDoux, 2012; Nummenmaa et al., 2014), processes inside (e.g., psychological processes) and outside the central nervous system, and/or environmental circumstances. However, the full range of feelings is diverse as they can emerge from emotions (Buck, 1985; Damasio and Carvalho, 2013; Panksepp, 2010), levels of arousal, actions (Bernroider and Panksepp, 2011; Gardiner, 2015), hedonics (pleasure and pain (Buck, 1985; Damasio and Carvalho, 2013; LeDoux, 2012; Panksepp, 2010), drives (Alcaro and Panksepp, 2011), cognitions (including perceptions/appraisals of self; Ellemers, 2012; Frewen et al., 2013; Northoff et al., 2009), motives (Higgins and Pittman, 2008), social interactions (Damasio and Carvalho, 2013; Gilam and Hendler, 2016; LeDoux, 2012; Panksepp, 2010) and both reflective (Holland and Kensinger, 2010) and anticipatory perspectives (Buck, 1985; Miloyan and Suddendorf, 2015).

The duration of feelings can vary considerably. They are often represented in language (Kircanski et al., 2012), although they can sometimes be difficult to recognize and verbalize, and some feelings can be influenced/shaped by culture (Immordino-Yang et al., 2014). Feelings that are adaptive in nature (Izard, 2007; Strigo and Craig, 2016) serve as a response to help an individual interpret, detect changes in, and make sense of their circumstances at any given point in time. This includes homeostatic feelings that influence other physiological/body states, other mental states, emotions, motives, actions and behaviors in support of adaptation and well-being (Damasio and Carvalho, 2013; Strigo and Craig, 2016). However, some feelings can be maladaptive in nature and may actually compete and/or interfere with goal-directed behavior.

A “feeling” is not a synonym for the term “emotion”. There is standing debate between researchers who posit that discrete emotion categories correspond to distinct brain regions (Izard, 2010) and those who argue that discrete emotion categories are constructed of generalized brain networks that are not specific to those categories (Lindquist et al., 2012). However, both groups acknowledge that in many instances feelings are a discernable component/constituent of an emotional response (which tends to more complex).

Using this definition of feelings as a starting point, the linguistics task team then undertook a formal linguistic analysis and ultimately proposed nine broad categories of feelings (i.e., Physiological or Bodily states, Attraction and Repulsion, Attention, Social, Actions and Prospects, Hedonics, Anger, General Wellbeing, and “Other”).

### 13.2. What new avenues in affective neuroscience might physiological feeling words suggest?

Physiological feelings (*ad-hoc* categorization shown in Table 1, full list in Supplementary Materials) were described as “feelings related to specific physiological/bodily states (e.g., hungry, warm, nauseous) including feelings that relate to the current status of mental function (e.g., dizzy, forgetful, etc.) and feelings related to energy levels (e.g. vital, tired)”. Not surprisingly, many of the words assigned to this category reflect interoceptive processes. Although the category of “Internal Bodily” in Table 1 refers specifically to interoceptive sensations, it is notable that words in other categories of feelings created by this *ad-hoc* grouping may also refer directly or indirectly to interoceptive sensation. This is particularly the case for the categories of “Energy” and “Overall Health”. In fact, when asked how we are feeling, the typical response

**Table 1**  
One representative parsing of physiological feeling words.

Category	Subcategory	
Drives	Air	
	Food	
	Sex	
	Water	
Energy	Rest	
	other	
Intoxication Overall health	General	
	Mental health	
	Muscular	
	Physical comfort	
	Sexual	
	Strength	
	Age	
	Internal bodily	Moisture
		Balance
		Mobility/flexibility
		General
		Hair
		Head
Heart		
Muscular		
Posture		
Pregnancy		
Skin (cleanliness)		
Skin (color)		
Skin (form)		
Stomach/bowel		
Vision		
Weight		
Other		
Sensation (external stimulus)	Moisture	
	Temperature (cold)	
	Temperature (hot)	
	General	
	Skin	
External challenge response	Body temperature	
	Mental clarity	
	Pain	
	Skin	
	Nerves	
Response to internal emotion	Mental clarity	
	Nerves	
	Skin	
	Skin (color)	
	General	

will incorporate words reflecting the summation and integration of information from numerous interoceptive sources many of which operate well below the level of conscious awareness. This is especially apparent when describing dysphoric states for which many have noted the similarity between terms reflecting mood (e.g., “depressed”), physical malaise or sickness (“not well”) and general energy (e.g., “dragged out”). The source of this similarity might be an in-common physiological process (e.g., acute phase of the innate immune response) or the similarity of expressed feelings may represent a final common pathway by which diverse types of homeostatic imbalance are perceived. A major difficulty for the neurophysiological study of interoception will be this non-specificity and difficulty in identifying dedicated neural pathways or labeled lines reflecting specific homeostatic processes (as can be done for exteroceptive input). And yet, we have little doubt, both experientially and scientifically, that how we feel reflects “something going on inside”. It is possible that a linguistic approach, combined with machine learning could do better at identifying the physiological source of the various inputs to the verbal output given when asked “how do you feel”. It is also possible that the words for feeling



states more precisely representing physiological inputs to subjective experience exist in languages other than English or even in non-scientific, traditional systems of bodily attunement (e.g., “energy fields” and the like). In any case, finding ways to measure, through verbal self-report, the activity of our internal milieu presents a unique challenge to neuroscientists quite unlike the relative ease of verbally tapping our experience of the exteroceptive senses.

### 13.3. Interactions with other affectome reviews

As the putative basis of experienced feelings, the actual physiological state of the body along with centrally generated (predicted) peripheral states play a key role in the other feeling states, not specifically identified as interoceptive, that are the foci of Human Affectome Project reviews, viz. feelings of Attraction and Repulsion, of Attention, Social Feelings, Actions and Prospects, Hedonics, Anger, and General Wellbeing. Drawing upon our own subjective experiences, it is not difficult to identify the physical sensations associated with each of the above. Moreover, in some cases, these other domains are associated with distinct visceral states (e.g., social disgust). One fruitful way to conceptualize the role of interoceptive feelings in each of the above emotional domains is to speculate as to their role in advancing the adaptive value of each domain over evolutionary time. Such roles, of course, extend back well past the origins of hominids and involve the presumed basic adaptive function of feelings in all higher organisms as markers for the salience of stimuli to survival and reproduction. For example: the physical manifestations of attraction guide us to sources of food and mates; repulsion protects us from toxins and disease; attention requires the physically aroused state of vigilance; social emotions rely upon our gut feelings of what is advantageous behavior (e.g., Damasio's somatic markers); hedonics utilize physically experienced reinforcement in promoting pursuit of the requirements for survival; anger mobilizes physiology for defense and competition; and feelings of wellbeing represent a summation of interoceptive sensations signaling different degrees of homeostatic balance and imbalance.

## 14. Conclusions

We have now explored the physiology of emotion from many perspectives including theoretical, evolutionary, anatomical, neurophysiological, interoceptive, autonomic, endocrine, immunological, reward, consciousness, regulatory, developmental and neuropsychiatric and linguistic viewpoints. Thematically we have focused on one way in which peripheral and central physiology influences subjective emotional experience, viz. interoception. The literature we have reviewed suggests that changes toward and away from homeostasis, not only within the autonomic nervous system but in all systems of the body (e.g., metabolic, cardiovascular, immune) contribute interoceptive information to the CNS. The integrated output of multiple physiological systems may provide highly complex inputs to central mechanisms that produce the conscious experience of feelings, moods and emotions. And such inputs may be modified by efferent signals at each level of the neuraxis. Thus, the many physiological influences on emotion may acquire specificity only when integrated with one another at the level of the brainstem or forebrain. We have also touched upon the notion of the Bayesian brain which suggests that this afferent flow of interoceptive information can be reversed such that predictions of emotional processes influence not only the perception of physiological change (e.g., as feelings) but also peripheral physiology itself (Barrett and Simmons, 2015; Seth, 2013; Seth and Friston, 2016). Clearly this is just a sampling – an effort to whet the appetite of new generations of psychologists and neuroscientists to consider the biology of emotion as a possible focus of their research. Current efforts to conceptualize the fundamental elements of human emotion continue to invoke the tensions articulated over a century ago by the contrasting James–Lange (bottom-up) and Cannon–Bard (top-down) viewpoints. Discoveries over this period,

however, have clearly revealed deep truths in both viewpoints. At the same time, new findings extend sources of emotion both further “downward” to the level of genes and their epigenetic modification, molecules and cells of the immune system and gut, and further “upward” to the level of neuronally instantiated cortical simulations that can predict and even prepare the physiological state of the body before it manifests. Of equal importance is the emerging view that, rather than being controller and “slave”, central and peripheral physiologies operate as a unified system with bidirectional flow of materials, energy and information. An emergent property of this system may be no less than the feelings of being a unified self – both as a physical body and as an entity that experiences feelings and emotions. This raises the question, so well articulated and explored by Antonio Damasio and others, as to the relationship between these emergent somatic feelings of selfhood and human consciousness (Damasio, 2010).

## Conflicts of interest

None.

## Acknowledgments

We thank Kylie N. Moore, Samuel Gazecki, Ryan Bottary, Brianna Pastro, Isabella Spaulding, Katrina Munoz and Dr. Per Davidson. Dr. Pace-Schott is supported by MH109638, MH115279.

## Appendix A. Supplementary data

Supplementary data associated with this article can be found, in the online version, at <https://doi.org/10.1016/j.neubiorev.2019.05.002>.

## References

- Adan, A., Archer, S.N., Hidalgo, M.P., Di Milia, L., Natale, V., Randler, C., 2012. Circadian typology: a comprehensive review. *Chronobiol. Int.* 29, 1153–1175.
- Ader, R., Felten, D.L., Cohen, N., 1991. *Psychoneuroimmunology*, 2nd ed. Academic Press, Inc., New York.
- Adolfi, F., Couto, B., Richter, F., Decety, J., Lopez, J., Sigman, M., Manes, F., Ibanez, A., 2017. Convergence of interoception, emotion, and social cognition: a twofold fMRI meta-analysis and lesion approach. *Cortex* 88, 124–142.
- Adolphs, R., Damasio, H., Tranel, D., Damasio, A.R., 1996. Cortical systems for the recognition of emotion in facial expressions. *J. Neurosci.* 16, 7678–7687.
- Adolphs, R., Tranel, D., Damasio, H., Damasio, A.R., 1995. Fear and the human amygdala. *J. Neurosci.* 15, 5879–5891.
- Aggarwal, M., Hyland, B.L., Wickens, J.R., 2012. Neural control of dopamine neurotransmission: implications for reinforcement learning. *Eur. J. Neurosci.* 35, 1115–1123.
- Ainley, V., Brass, M., Tsakiris, M., 2014. Heartfelt imitation: high interoceptive awareness is linked to greater automatic imitation. *Neuropsychologia* 60, 21–28.
- Ainley, V., Maister, L., Tsakiris, M., 2015. Heartfelt empathy? No association between interoceptive awareness, questionnaire measures of empathy, reading the mind in the eyes task or the director task. *Front. Psychol.* 6, 554.
- Alcaro, A., Panksepp, J., 2011. The SEEKING mind: primal neuro-affective substrates for appetitive incentive states and their pathological dynamics in addictions and depression. *Neurosci. Biobehav. Rev.* 35, 1805–1820.
- Amole, M.C., Cyranowski, J.M., Wright, A.G., Swartz, H.A., 2017. Depression impacts the physiological responsiveness of mother–daughter dyads during social interaction. *Depress. Anxiety* 34, 118–126.
- Apkarian, A.V., Hashmi, J.A., Baliki, M.N., 2011. Pain and the brain: specificity and plasticity of the brain in clinical chronic pain. *Pain* 152, S49–S64.
- Armony, J.L., Dolan, R.J., 2002. Modulation of spatial attention by fear-conditioned stimuli: an event-related fMRI study. *Neuropsychologia* 40, 817–826.
- Arnsten, A.F., 2015. Stress weakens prefrontal networks: molecular insults to higher cognition. *Nat. Neurosci.* 18, 1376–1385.
- Aue, T., Flykt, A., Scherer, K.R., 2007. First evidence for differential and sequential efferent effects of stimulus relevance and goal conduciveness appraisal. *Biol. Psychol.* 74, 347–357.
- Ax, A.F., 1953. The physiological differentiation between fear and anger in humans. *Psychosom. Med.* 15, 433–442.
- Babo-Rebelo, M., Wolpert, N., Adam, C., Hasboun, D., Tallon-Baudry, C., 2016. Is the cardiac monitoring function related to the self in both the default network and right anterior insula? *Philos. Trans. R. Soc. Lond. B: Biol. Sci.* 371.
- Baer, R.A., 2003. Mindfulness training as a clinical intervention: a conceptual and empirical review. *Clin. Psychol.: Sci. Pract.* 10, 125–143.
- Balzarotti, S., Biondini, F., Colombo, B., Ciceri, M.R., 2017. Cardiac vagal control as a marker of emotion regulation in healthy adults: a review. *Biol. Psychol.* 130, 54–66.
- Bard, P., 1928. A diencephalic mechanism for the expression of rage with special reference to the sympathetic nervous system. *Am. J. Physiol.* 84, 490–516.



- Barichello, T., Simoes, L.R., Collodel, A., Giridharan, V.V., Dal-Pizzol, F., Macedo, D., Quevedo, J., 2017. The translocator protein (18 kDa) and its role in neuropsychiatric disorders. *Neurosci. Biobehav. Rev.* 83, 183–199.
- Barrett, L., 2017a. How Emotions are Made – The Secret Life of the Brain. Houghton Mifflin Harcourt, Boston.
- Barrett, L.F., 2006. Are emotions natural kinds? *Perspect. Psychol. Sci.* 1, 28–58.
- Barrett, L.F., 2017b. The theory of constructed emotion: an active inference account of interoception and categorization. *Soc. Cogn. Affect. Neurosci.* 12, 1–23.
- Barrett, L.F., 2017c. The theory of constructed emotion: an active inference account of interoception and categorization. *Soc. Cogn. Affect. Neurosci.*
- Barrett, L.F., Quigley, K.S., Hamilton, P., 2016. An active inference theory of allostasis and interoception in depression. *Philos. Trans. R. Soc. Lond. B: Biol. Sci.* 371.
- Barrett, L.F., Satpute, A.B., 2013. Large-scale brain networks in affective and social neuroscience: towards an integrative functional architecture of the brain. *Curr. Opin. Neurobiol.* 23, 361–372.
- Barrett, L.F., Simmons, W.K., 2015. Interoceptive predictions in the brain. *Nat. Rev.* 16, 419–429.
- Barrett, L.F., Tugade, M.M., Engle, R.W., 2004. Individual differences in working memory capacity and dual-process theories of mind. *Psychol. Bull.* 130, 553–573.
- Bauer, M.R., Ruef, A.M., Pineles, S.L., Japuntich, S.J., Macklin, M.L., Lasko, N.B., Orr, S.P., 2013. Psychophysiological assessment of PTSD: a potential research domain criteria construct. *Psychol. Assess.* 25, 1037–1043.
- Bechara, A., 2005. Decision making, impulse control and loss of willpower to resist drugs: a neurocognitive perspective. *Nat. Neurosci.* 8, 1458–1463.
- Beedie, C.J., Terry, P.C., Lane, A.M., 2005. Distinctions between emotion and mood. *Cogn. Emotion* 19, 847–878.
- Benarroch, E.E., 1993. The central autonomic network: functional organization, dysfunction, and perspective. *Mayo Clin. Proc.* 68, 988–1001.
- Beraha, E., Eggers, J., Hindi Attar, C., Gutwinski, S., Schlagenhaupt, F., Stoy, M., Sterzer, P., Kienast, T., Heinz, A., Birmohl, F., 2012. Hemispheric asymmetry for affective stimulus processing in healthy subjects – a fMRI study. *PLoS ONE* 7, e46931.
- Bernroider, G., Panksepp, J., 2011. Mirrors and feelings: have you seen the actors outside? *Neurosci. Biobehav. Rev.* 35, 2009–2016.
- Bernston, G.G., Bechara, A., Damasio, H., Tranel, D., Cacioppo, J.T., 2007. Amygdala contribution to selective dimensions of emotion. *Soc. Cogn. Affect. Neurosci.* 2, 123–129.
- Bernston, G.G., Cacioppo, J.T., Quigley, K.S., 1991. Autonomic determinism: the modes of autonomic control, the doctrine of autonomic space, and the laws of autonomic constraint. *Psychol. Rev.* 98, 459–487.
- Bernston, G.G., Norman, G.J., Hawley, L.C., Cacioppo, J.T., 2008. Cardiac autonomic balance versus cardiac regulatory capacity. *Psychophysiology* 45, 643–652.
- Berridge, K.C., Kringelbach, M.L., 2015. Pleasure systems in the brain. *Neuron* 86, 646–664.
- Berridge, K.C., Robinson, T.E., 2016. Liking, wanting, and the incentive-sensitization theory of addiction. *Am. Psychol.* 71, 670–679.
- Berthoud, H.R., Neuhuber, W.L., 2000. Functional and chemical anatomy of the afferent vagal system. *Auton. Neurosci.* 85, 1–17.
- Betka, S., Gould Van Praag, C., Paloyelis, Y., Bond, R., Pfeifer, G., Sequeira, H., Duka, T., Critchley, H., 2018. Impact of intranasal oxytocin on interoceptive accuracy in alcohol users: an attentional mechanism? *Soc. Cogn. Affect. Neurosci.*
- Billingsley, J., Lieberman, D., Tybur, J.M., 2018. Sexual disgust trumps pathogen disgust in predicting voter behavior during the 2016 U.S. Presidential Election. *Evol. Psychol.* 16 1474704918764170.
- Binder, E.B., Nemeroff, C.B., 2010. The CRF system, stress, depression and anxiety-insights from human genetic studies. *Mol. Psychiatry* 15, 574–588.
- Blanck, P., Perleth, S., Heidenreich, T., Kroger, P., Ditzgen, B., Bents, H., Mander, J., 2017. Effects of mindfulness exercises as stand-alone intervention on symptoms of anxiety and depression: systematic review and meta-analysis. *Behav. Res. Ther.* 102, 25–35.
- Blascovich, J., Tomaka, J., 1996. The biopsychosocial model of arousal regulation. *Adv. Exp. Soc. Psychol.* 28, 1–51.
- Blumberg, M.S., Plumeau, A.M., 2015. A new view of “dream enactment” in REM sleep behavior disorder. *Sleep Med. Rev.* 30, 34–42.
- Boettcher, H., Brake, C.A., Barlow, D.H., 2016. Origins and outlook of interoceptive exposure. *J. Behav. Ther. Exp. Psychiatry* 53, 41–51.
- Bohlmeijer, E., Prenger, R., Taal, E., Cuijpers, P., 2010. The effects of mindfulness-based stress reduction therapy on mental health of adults with a chronic medical disease: a meta-analysis. *J. Psychosom. Res.* 68, 539–544.
- Boiger, M., Mesquita, B., 2012. The construction of emotion in interactions, relationships, and cultures. *Emotion Rev.* 4, 221–229.
- Boly, M., Faymonville, M.E., Schnakers, C., Peigneux, P., Lambermont, B., Phillips, C., Lancellotti, P., Luxen, A., Lamy, M., Moonen, G., Maquet, P., Laureys, S., 2008. Perception of pain in the minimally conscious state with PET activation: an observational study. *Lancet Neurol.* 7, 1013–1020.
- Bonala, B.K., Jansen, B.H., 2012. A computational model for generation of the P300 evoked potential component. *J. Integr. Neurosci.* 11, 277–294.
- Borbely, A.A., 1982. A two process model of sleep regulation. *Hum. Neurobiol.* 1, 195–204.
- Bornemann, B., Singer, T., 2017. Taking time to feel our body: steady increases in heartbeat perception accuracy and decreases in alexithymia over 9 months of contemplative mental training. *Psychophysiology* 54, 469–482.
- Borod, J.C., Cicero, B.A., Obler, L.K., Welkowitz, J., Erhan, H.M., Santschi, C., Grunwald, I.S., Agosti, R.M., Whalen, J.R., 1998. Right hemisphere emotional perception: evidence across multiple channels. *Neuropsychology* 12, 446–458.
- Borod, J.C., Zgaljardic, D., Tabert, M.H., Koff, E., 2001. Asymmetries of emotional perception and expression in normal adults. *Handbook of Neuropsychology*, 2nd ed. Elsevier, Amsterdam.
- Borsook, D., Youssef, A.M., Barakat, N., Sieberg, C.B., Elman, I., 2018. Subliminal (latent) processing of pain and its evolution to conscious awareness. *Neurosci. Biobehav. Rev.* 88, 1–15.
- Bradley, M.M., Greenwald, M.K., Petry, M.C., Lang, P.J., 1992. Remembering pictures: pleasure and arousal in memory. *J. Exp. Psychol. Learn. Mem. Cogn.* 18, 379–390.
- Bradley, M.M., Lang, P.J., 2007. Emotion and motivation. In: Cacioppo, J.T., Tassinary, L.G., Bernston, G.G. (Eds.), *Handbook of Psychophysiology*, 3rd ed. Cambridge University Press, Cambridge, UK.
- Braun, A.R., Balkin, T.J., Wesensten, N.J., Gwady, F., Carson, R.E., Varga, M., Baldwin, P., Belenky, G., Herscovitch, P., 1998. Dissociated pattern of activity in visual cortices and their projections during human rapid eye movement sleep. *Science* 279, 91–95.
- Braun, A.R., Balkin, T.J., Wesensten, N.J., Carson, R.E., Varga, M., Baldwin, P., Selbie, S., Belenky, G., Herscovitch, P., 1997. Regional cerebral blood flow throughout the sleep-wake cycle. An H2(15)O PET study. *Brain* 120 (Pt 7), 1173–1197.
- Brener, J., Ring, C., 2016. Towards a psychophysics of interoceptive processes: the measurement of heartbeat detection. *Philos. Trans. R. Soc. Lond. B: Biol. Sci.* 371.
- Bress, J.N., Foti, D., Kotov, R., Klein, D.N., Hajcak, G., 2013. Blunted neural response to rewards prospectively predicts depression in adolescent girls. *Psychophysiology* 50, 74–81.
- Bress, J.N., Smith, E., Foti, D., Klein, D.N., Hajcak, G., 2012. Neural response to reward and depressive symptoms in late childhood to early adolescence. *Biol. Psychol.* 89, 156–162.
- Brewer, R., Happe, F., Cook, R., Bird, G., 2015. Commentary on “Autism, oxytocin and interoception”: Alexithymia, not Autism Spectrum Disorders, is the consequence of interoceptive failure. *Neurosci. Biobehav. Rev.* 56, 348–353.
- Bridgett, D.J., Oddi, K.B., Laake, K.M., Murdock, K.W., Bachmann, K.M., 2013. Integrating and differentiating aspects of self-regulation: effortful control, executive functioning, and links to negative affectivity. *Emotion (Washington, DC)* 13, 47–63.
- Brossey, E.A., Woodward, N.D., 2017. Neuroanatomical correlates of perceptual aberrations in psychosis. *Schizophr. Res.* 179, 125–131.
- Brown, S.B., van Steenbergen, H., Band, G.P., de Rover, M., Nieuwenhuis, S., 2012. Functional significance of the emotion-related late positive potential. *Front. Hum. Neurosci.* 6, 33.
- Broyd, S.J., Richards, H.J., Helps, S.K., Chronaki, G., Bamford, S., Sonuga-Barke, E.J., 2012. An electrophysiological monetary incentive delay (e-MID) task: a way to decompose the different components of neural response to positive and negative monetary reinforcement. *J. Neurosci. Methods* 209, 40–49.
- Bruno, M.M., Nizzi, S., Laureys, S., Gosseries, O., 2015. The locked-in syndrome. In: Tononi, G., Gosseries, O. (Eds.), *The Neurology of Consciousness*, 2nd ed. Academic Press/Elsevier.
- Buck, R., 1985. Prime theory: an integrated view of motivation and emotion. *Psychol. Rev.* 92 (3), 389–413.
- Busch, V., Zeman, F., Heckel, A., Menne, F., Ellrich, J., Eichhammer, P., 2013. The effect of transcatheter vagus nerve stimulation on pain perception – an experimental study. *Brain Stimul.* 6, 202–209.
- Butler, E.A., 2011. Temporal interpersonal emotion systems: the “TIES” that form relationships. *Personal. Soc. Psychol. Rev.* 15, 367–393.
- Butler, E.A., Randall, A.K., 2013. Emotional coregulation in close relationships. *Emotion Rev.* 5, 202–210.
- Bylsma, L.M., 2012. Emotional Reactivity and Regulation in Current and Remitted Depression: An Event Related Potential Study. University of South Florida.
- Bylsma, L.M., Salomon, K., Taylor-Clift, A., Morris, B.H., Rottenberg, J., 2014. Respiratory sinus arrhythmia reactivity in current and remitted major depressive disorder. *Psychosom. Med.* 76, 66–73.
- Bylsma, L.M., Yaroslavsky, I., Rottenberg, J., Jennings, J.R., George, C.J., Kiss, E., Kapornai, K., Halas, K., Dochnal, R., Lefkovic, E., Benak, I., Baji, I., Vetro, A., Kovacs, M., 2015. Juvenile onset depression alters cardiac autonomic balance in response to psychological and physical challenges. *Biol. Psychol.* 110, 167–174.
- Cacioppo, J.T., Bernston, G.G., Klein, D.J., Poehlmann, K.M., 1997. The psychophysiology of emotion across the lifespan. *Annu. Rev. Gerontol. Geriatr.* 17, 27–74.
- Cacioppo, J.T., Bernston, G.G., Larsen, J.T., Poehlmann, K.M., Ito, T.A., 2000. The psychophysiology of emotion. *Handbook of Emotions*, pp. 173–191.
- Cacioppo, J.T., Tassinary, L.G., Bernston, G.G., 2017. *Handbook of Psychophysiology*, 4th ed. Cambridge University Press, New York.
- Cahill, L., McGaugh, J.L., 1995. A novel demonstration of enhanced memory associated with emotional arousal. *Conscious. Cogn.* 4, 410–421.
- Calkins, S.D., Dedmon, S.E., Gill, K.L., Lomax, L.E., Johnson, L.M., 2002. Frustration in infancy: implications for emotion regulation, physiological processes, and temperament. *Infancy* 3, 175–198.
- Cameron, O.G., 2001. *Visceral Sensory Neuroscience*. Oxford University Press, New York, NY.
- Cannon, W.B., 1927. The James–Lange theory of emotions: a critical examination and an alternative theory. *Am. J. Psychol.* 39, 106–124.
- Cannon, W.B., 1928. The mechanism of emotional disturbance of bodily functions. *N. Engl. J. Med.* 198, 877–884.
- Carstensen, L.L., Fung, H.H., Charles, S.T., 2003. Socioemotional selectivity theory and the regulation of emotion in the second half of life. *Motivation Emotion* 27, 103–123.
- Cartwright, R., Luten, A., Young, M., Mercer, P., Bears, M., 1998. Role of REM sleep and dream affect in overnight mood regulation: a study of normal volunteers. *Psychiatry Res.* 81, 1–8.
- Carver, C.S., Harmon-Jones, E., 2009. Anger is an approach-related affect: evidence and implications. *Psychol. Bull.* 135, 183.
- Carver, C.S., Sutton, S.K., Scheier, M.F., 2000. Action, emotion, and personality: emerging conceptual integration. *Personal. Soc. Psychol. Bull.* 26, 741–751.
- Castro, M., Tillmann, B., Luaute, J., Corneille, A., Dailier, F., Andre-Obadia, N., Perrin, F., 2015. Boosting cognition with music in patients with disorders of consciousness. *Neurorehabil. Neural Repair* 29, 734–742.
- CDC, 2016. Prescribing opioids for chronic pain. In: CfDca (Ed.), *Prevention CDC*, Washington, DC.
- Celegnin, A., Diano, M., Bagnis, A., Viola, M., Tamietto, M., 2017. Basic emotions in human neuroscience: neuroimaging and beyond. *Front. Psychol.* 8, 1432.
- Ceunen, E., Vlaeyen, J.W., Van Diest, I., 2016. On the origin of interoception. *Front. Psychol.* 7, 743.
- Charles, S.T., Mather, M., Carstensen, L.L., 2003. Aging and emotional memory: the

- forgettable nature of negative images for older adults. *J. Exp. Psychol. Gen.* 132, 310–324.
- Cheng, L., Gosseries, O., Ying, L., Hu, X., Yu, D., Gao, H., He, M., Schnakers, C., Laureys, S., Di, H., 2013. Assessment of localisation to auditory stimulation in post-comatose states: use the patient's own name. *BMC Neurol.* 13, 27.
- Chiara, G., Calandra-Buonaura, G., Cecere, A., Mignani, F., Sambati, L., Loddò, G., Cortelli, P., Provini, F., 2017. REM sleep behavior disorder, autonomic dysfunction and synuclein-related neurodegeneration: where do we stand? *Clin. Auton. Res.*
- Chiesa, A., Serretti, A., 2009. Mindfulness-based stress reduction for stress management in healthy people: a review and meta-analysis. *J. Altern. Complement. Med.* 15, 593–600.
- Chiesa, A., Serretti, A., Jakobsen, J.C., 2013. Mindfulness: top-down or bottom-up emotion regulation strategy? *Clin. Psychol. Rev.* 33, 82–96.
- Choy, E.H., 2015. The role of sleep in pain and fibromyalgia. *Nat. Rev. Rheumatol.* 11, 513–520.
- Christianson, S.-Å., Loftus, E.F., 1991. Remembering emotional events: the fate of detailed information. *Cogn. Emotion* 5, 81–108.
- Christie, I.C., Friedman, B.H., 2004. Autonomic specificity of discrete emotion and dimensions of affective space: a multivariate approach. *Int. J. Psychophysiol.* 51, 143–153.
- Chwalisz, K., Diener, E., Gallagher, D., 1988. Autonomic arousal feedback and emotional experience: evidence from the spinal cord injured. *J. Pers. Soc. Psychol.* 54, 820–828.
- Citron, F.M.M., Gray, M.A., Critchley, H.D., Weekes, B.S., Ferstl, E.C., 2014. Emotional valence and arousal affect reading in an interactive way: neuroimaging evidence for an approach-withdrawal framework. *Neuropsychologia* 56, 79–89.
- Clemens, S., Rye, D., Hochman, S., 2006. Restless legs syndrome: revisiting the dopamine hypothesis from the spinal cord perspective. *Neurology* 67, 125–130.
- Clough, B.A., Casey, L.M., 2011. Technological adjuncts to enhance current psychotherapy practices: a review. *Clin. Psychol. Rev.* 31, 279–292.
- Cosmides, L., Tooby, J., 2013. Evolutionary psychology: new perspectives on cognition and motivation. *Annu. Rev. Psychol.* 64, 201–229.
- Costanzo, M.E., Leaman, S., Jovanovic, T., Norrholm, S.D., Rizzo, A.A., Taylor, P., Roy, M.J., 2014. Psychophysiological response to virtual reality and subthreshold post-traumatic stress disorder symptoms in recently deployed military. *Psychosom. Med.* 76, 670–677.
- Craig, A.D., 2002. How do you feel? Interoception: the sense of the physiological condition of the body. *Nat. Rev.* 3, 655–666.
- Craig, A.D., 2003a. Interoception: the sense of the physiological condition of the body. *Curr. Opin. Neurobiol.* 13, 500–505.
- Craig, A.D., 2003b. Pain mechanisms: labeled lines versus convergence in central processing. *Annu. Rev. Neurosci.* 26, 1–30.
- Craig, A.D., 2009. How do you feel – now? The anterior insula and human awareness. *Nat. Rev.* 10, 59–70.
- Craig, A.D., 2010. Interoception and emotion. A neuroanatomical perspective. In: Lewis, M., Haviland-Jones, J.M., Barrett, L.F. (Eds.), *Handbook of Emotions*, 3rd ed. Guilford, New York, pp. 272–288.
- Craig, A.D., 2011. Significance of the insula for the evolution of human awareness of feelings from the body. *Ann. N. Y. Acad. Sci.* 1225, 72–82.
- Craig, A.D., 2016. How Do You Feel? An Interoceptive Moment with Your Neurobiological Self. Princeton University Press, Princeton.
- Crick, F.H., 1994. The Astonishing Hypothesis. Touchstone, Simon and Schuster, New York.
- Cripe, L.D., Frankel, R.M., 2017. Dying from cancer: communication, empathy, and the clinical imagination. *J. Patient Exp.* 4, 69–73.
- Critchley, H.D., 2002. Electrodermal responses: what happens in the brain. *Neuroscientist* 8, 132–142.
- Critchley, H.D., 2005. Neural mechanisms of autonomic, affective, and cognitive integration. *J. Comp. Neurol.* 493, 154–166.
- Critchley, H.D., Garfinkel, S.N., 2017. Interoception and emotion. *Curr. Opin. Psychol.* 17, 7–14.
- Critchley, H.D., Harrison, N.A., 2013. Visceral influences on brain and behavior. *Neuron* 77, 624–638.
- Critchley, H.D., Wiens, S., Rotshtein, P., Ohman, A., Dolan, R.J., 2004. Neural systems supporting interoceptive awareness. *Nat. Neurosci.* 7, 189–195.
- Crowley, S.J., Acebo, C., Carskadon, M.A., 2007. Sleep, circadian rhythms, and delayed phase in adolescence. *Sleep Med.* 8, 602–612.
- Cruse, D., Chennu, S., Chatelle, C., Fernandez-Espejo, D., Bekinschtein, T.A., Pickard, J.D., Laureys, S., Owen, A.M., 2012. Relationship between etiology and covert cognition in the minimally conscious state. *Neurology* 78, 816–822.
- Cryan, J.F., Dinan, T.G., 2012. Mind-altering microorganisms: the impact of the gut microbiota on brain and behaviour. *Nat. Rev.* 13, 701–712.
- Cryan, J.F., Dinan, T.G., 2015. More than a gut feeling: the microbiota regulates neurodevelopment and behavior. *Neuropsychopharmacology* 40, 241–242.
- Cuthbert, B.N., Schupp, H.T., Bradley, M.M., Birbaumer, N., Lang, P.J., 2000. Brain potentials in affective picture processing: covariation with autonomic arousal and affective report. *Biol. Psychol.* 52, 95–111.
- D'Agostino, A., Manni, R., Limosani, I., Terzaghi, M., Cavallotti, S., Scarone, S., 2012. Challenging the myth of REM sleep behavior disorder: no evidence of heightened aggressiveness in dreams. *Sleep Med.* 13, 714–719.
- Daltrozzo, J., Wioland, N., Mutschler, V., Lutun, P., Calon, B., Meyer, A., Jaeger, A., Pottecher, T., Kotchoubey, B., 2010. Emotional electrodermal response in coma and other low-responsive patients. *Neurosci. Lett.* 475, 44–47.
- Damasio, A., 2010. *Self Comes to Mind: Constructing the Conscious Brain*. Pantheon Books, New York.
- Damasio, A., Carvalho, G.B., 2013. The nature of feelings: evolutionary and neurobiological origins. *Nat. Rev.* 14, 143–152.
- Damasio, A.R., 1994. *Descartes' Error: Emotion, Rationality and the Human Brain*. Damasio, A.R., 1996. The somatic marker hypothesis and the possible functions of the prefrontal cortex. *Philos. Trans. R. Soc. Lond. B: Biol. Sci.* 351, 1413–1420.
- Damasio, A.R., Grabowski, T.J., Bechara, A., Damasio, H., Ponto, L.L., Parvizi, J., Hichwa, R.D., 2000. Subcortical and cortical brain activity during the feeling of self-generated emotions. *Nat. Neurosci.* 3, 1049–1056.
- Damsma, G., Pfaus, J.G., Wenkstern, D., Phillips, A.G., Fibiger, H.C., 1992. Sexual behavior increases dopamine transmission in the nucleus accumbens and striatum of male rats: comparison with novelty and locomotion. *Behav. Neurosci.* 106, 181–191.
- Dantzer, R., Kelley, K.W., 2007. Twenty years of research on cytokine-induced sickness behavior. *Brain Behav. Immun.* 21, 153–160.
- Darwin, C., 1859. *On the Origin of Species by Means of Natural Selection, or the Preservation of Favoured Races in the Struggle for Life*.
- Darwin, C., 1872. *The Expression of the Emotions in Man and Animals*. Oxford University Press, USA.
- Davidson, R.J., 1984. Affect, cognition and hemispheric specialization. In: Izard, C.E., Kagan, J., Zajonc, R. (Eds.), *Emotion, Cognition and Behavior*. Cambridge University Press, New York, pp. 320–365.
- Davidson, R.J., 1998. Affective style and affective disorders: perspectives from affective neuroscience. *Cogn. Emotion* 12, 307–330.
- Davidson, R.J., Ekman, P., Saron, C.D., Senulis, J.A., Friesen, W.V., 1990. Approach-withdrawal and cerebral asymmetry: emotional expression and brain physiology. *J. Pers. Soc. Psychol.* 58, 330–341.
- Davidson, R.J., Putnam, K.M., Larson, C.L., 2000. Dysfunction in the neural circuitry of emotion regulation – a possible prelude to violence. *Science* 289, 591–594.
- Davis, C.J., Krueger, J.M., 2012. Sleep and cytokines. *Sleep Med. Clin.* 7, 517–527.
- Davis, K.F., Parker, K.P., Montgomery, G.L., 2004. Sleep in infants and young children: part one: normal sleep. *J. Pediatr. Health Care* 18, 65–71.
- Davis, M., 1989. Neural systems involved in fear-potentiated startle. *Ann. N.Y. Acad. Sci.* 563, 165–183.
- Davis, M., 1992. The role of the amygdala in fear-potentiated startle: implications for animal models of anxiety. *Trends Pharmacol. Sci.* 13, 35–41.
- Davis, M., Walker, D.L., Miles, L., Grillon, C., 2010. Phasic vs sustained fear in rats and humans: role of the extended amygdala in fear vs anxiety. *Neuropsychopharmacology* 35, 105–135.
- Dawson, M.E., Schell, A.M., Filion, D.L., 2007. The electrodermal system. In: Cacioppo, J.T., Tassinary, L.G., Berntson, G.G. (Eds.), *Handbook of Psychophysiology*, 3rd ed. Cambridge University Press, New York, pp. 159–181.
- De Cort, K., Schrijnen, M., Hurlmann, R., Claassen, S., Hoogenhout, J., Van den Bergh, O., Goossens, L., Van Diest, I., Schruers, K., 2017. Modeling the development of panic disorder with interoceptive conditioning. *Eur. Neuropsychopharmacol.* 27, 59–69.
- de Vignemont, F., Singer, T., 2006. The empathic brain: how, when and why? *Trends Cogn. Sci.* 10, 435–441.
- De Witte, N.A., Sütterlin, S., Braet, C., Mueller, S.C., 2016. Getting to the heart of emotion regulation in youth: the role of interoceptive sensitivity, heart rate variability, and parental psychopathology. *PLoS ONE* 11, 1–17.
- de Zambotti, M., Trinder, J., Silvani, A., Colrain, I.M., Baker, F.C., 2018. Dynamic coupling between the central and autonomic nervous systems during sleep: a review. *Neurosci. Biobehav. Rev.* 90, 84–103.
- Del Giudice, R., Blume, C., Wisłowska, M., Lechinger, J., Heib, D.P.J., Pichler, G., Donis, J., Michitsch, G., Gnjezda, M.T., Chinchilla, M., Machado, C., Schabus, M., 2016. Can self-relevant stimuli help assessing patients with disorders of consciousness? *Conscious. Cogn.* 44, 51–60.
- Delgado, M.R., Nearing, K.I., Ledoux, J.E., Phelps, E.A., 2008. Neural circuitry underlying the regulation of conditioned fear and its relation to extinction. *Neuron* 59, 829–838.
- Demaree, H.A., Robinson, J.L., Pu, J., Allen, J.J.B., 2006. Strategies actually employed during response-focused emotion regulation research: affective and physiological consequences. *Cogn. Emotion* 20, 1248–1260.
- Dennis, T.A., Malone, M.M., Chen, C.C., 2009. Emotional face processing and emotion regulation in children: an ERP study. *Dev. Neuropsychol.* 34, 85–102.
- Derrfuss, J., Mar, R.A., 2009. Lost in localization: the need for a universal coordinate database. *Neuroimage* 48.
- Descalzi, G., Ikegami, D., Ushijima, T., Nestler, E.J., Zachariou, V., Narita, M., 2015. Epigenetic mechanisms of chronic pain. *Trends Neurosci.* 38, 237–246.
- Dessalles, M., Dang-Vu, T.T., Sterpenich, V., Schwartz, S., 2010. Cognitive and emotional processes during dreaming: a neuroimaging view. *Conscious. Cogn.*
- DeWall, C.N., Twenge, J.M., Koole, S.L., Baumeister, R.F., Marquez, A., Reid, M.W., 2011. Automatic emotion regulation after social exclusion: turning to positivity. *Emotion (Washington, DC)* 11, 623–636.
- Di Lerna, D., Serino, S., Riva, G., 2016. Pain in the body. Altered interoception in chronic pain conditions: a systematic review. *Neurosci. Biobehav. Rev.* 71, 328–341.
- Dickerson, S.S., Kemeny, M.E., 2004. Acute stressors and cortisol responses: a theoretical integration and synthesis of laboratory research. *Psychol. Bull.* 130, 355–391.
- Diorio, D., Viau, V., Meaney, M.J., 1993. The role of the medial prefrontal cortex (cingulate gyrus) in the regulation of hypothalamic-pituitary-adrenal responses to stress. *J. Neurosci.* 13, 3839–3847.
- Diver, M.J., Imtiaz, K.E., Ahmad, A.M., Vora, J.P., Fraser, W.D., 2003. Diurnal rhythms of serum total, free and bioavailable testosterone and of SHBG in middle-aged men compared with those in young men. *Clin. Endocrinol. (Oxf.)* 58, 710–717.
- Domschke, K., Stevens, S., Pfleiderer, B., Gerlach, A.L., 2010. Interoceptive sensitivity in anxiety and anxiety disorders: an overview and integration of neurobiological findings. *Clin. Psychol. Rev.* 30, 1–11.
- Dörfel, D., Lamke, J.P., Hummel, F., Wagner, U., Erk, S., Walter, H., 2014. Common and differential neural networks of emotion regulation by detachment, reinterpretation, distraction, and expressive suppression: a comparative fMRI investigation. *Neuroimage* 101, 298–309.
- Duffy, E., 1972. Activation. In: Greenfield, N.S., Sternbach, R.A. (Eds.), *Handbook of Psychophysiology*. Holt, Rinehart & Winston, New York City, NY, pp. 577–622.
- Duits, P., Cath, D.C., Lissek, S., Hox, J.J., Hamm, A.O., Engelhard, I.M., van den Hout, M.A., Baas, J.M., 2015. Updated meta-analysis of classical fear conditioning in the anxiety disorders. *Depress. Anxiety* 32, 239–253.
- Eickhoff, S.B., Laird, A.R., Fox, P.T., Bzdok, D., Hensel, L., 2016. Functional segregation of the human dorsomedial prefrontal cortex. *Cereb. Cortex* 26, 304–321.
- Eisenberg, N., Spinrad, T.L., 2004. Emotion-related regulation: sharpening the definition.

- Child Dev. 75, 334–339.
- Eisenberger, N.L., Berkman, E.T., Inagaki, T.K., Rameson, L.T., Mashal, N.M., Irwin, M.R., 2010. Inflammation-induced anhedonia: endotoxin reduces ventral striatum responses to reward. *Biol. Psychiatry* 68, 748–754.
- Ekman, P., 1984. Expression and the nature of emotion. In: Scherer, K., Ekman, P. (Eds.), *Approaches to Emotion*. Erlbaum, Hillsdale, NJ.
- Ekman, P., 1992a. Are there basic emotions? *Psychol. Rev.* 99, 550–553.
- Ekman, P., 1992b. An argument for basic emotions. *Cogn. Emotion* 6, 169–200.
- Ekman, P., 1993. Facial expression and emotion. *Am. Psychol.* 48, 384–392.
- Ekman, P., 1999. Basic emotions. In: Dalgleish, T., Power, M.J. (Eds.), *Handbook of Cognition and Emotion*. Wiley, Chichester, UK.
- Ekman, P., Sorenson, E.R., Friesen, W.V., 1969. Pan-cultural elements in facial displays of emotion. *Science* 164, 86–88.
- Electrophysiology, T.F.o.t.E.S.o.C.a.t.N.A.S.o.P.a., 1996. Heart rate variability: standards of measurement, physiological interpretation and clinical use. Task Force of the European Society of Cardiology and the North American Society of Pacing and Electrophysiology. *Circulation* 93, 1043–1065.
- Elfenbein, H.A., Ambady, N., 2002. On the universality and cultural specificity of emotion recognition: a meta-analysis. *Psychol. Bull.* 128, 203–235.
- Elfenbein, H.A., Ambady, N., 2003. Universal and cultural differences in recognizing emotions. *Curr. Directions Psychol. Sci.* 12, 159–164.
- Ellemers, N., 2012. The group self. *Science* 336, 848–852.
- Ellsworth, P.C., 2013. Appraisal theory: old and new questions. *Emotion Rev.* 5, 125–131.
- Engman, J., Linnman, C., Van Dijk, K.R., Milad, M.R., 2016. Amygdala subnuclei resting-state functional connectivity sex and estrogen differences. *Psychoneuroendocrinology* 63, 34–42.
- Ernst, J., Northoff, G., Boker, H., Seifritz, E., Grimm, S., 2013. Interoceptive awareness enhances neural activity during empathy. *Hum. Brain Mapp.* 34, 1615–1624.
- Ewing, D.L., Manassei, M., Gould van Praag, C., Philippides, A.O., Critchley, H.D., Garfinkel, S.N., 2017. Sleep and the heart: interoceptive differences linked to poor experiential sleep quality in anxiety and depression. *Biol. Psychol.* 127, 163–172.
- Fahrenberg, J., Foerster, F., 1982. Covariation and consistency of activation parameters. *Biol. Psychol.* 15, 151–169.
- Fairclough, S.H., Goodwin, L., 2007. The effect of psychological stress and relaxation on interoceptive accuracy: implications for symptom perception. *J. Psychosom. Res.* 62, 289–295.
- Falkenstein, M., Hoormann, J., Hohnsbein, J., Kleinsorge, T., 2003. Short-term mobilization of processing resources is revealed in the event-related potential. *Psychophysiology* 40, 914–923.
- Fan, J., Kolster, R., Ghajar, J., Suh, M., Knight, R.T., Sarkar, R., McCandliss, B.D., 2007. Response anticipation and response conflict: an event-related potential and functional magnetic resonance imaging study. *J. Neurosci.* 27, 2272–2282.
- Fantini, M.L., Corona, A., Clerici, S., Ferini-Strambi, L., 2005. Aggressive dream content without daytime aggressiveness in REM sleep behavior disorder. *Neurology* 65, 1010–1015.
- Faraud, B., Leger, D., Medkour, T., Dubois, A., Bayon, V., Chennaoui, M., Perrot, S., 2015a. Napping reverses increased pain sensitivity due to sleep restriction. *PLoS ONE* 10, e0117425.
- Faraud, B., Nakib, S., Drogou, C., Elbaz, M., Sauvet, F., De Bandt, J.P., Leger, D., 2015b. Napping reverses the salivary interleukin-6 and urinary norepinephrine changes induced by sleep restriction. *J. Clin. Endocrinol. Metab.* 100, E416–E426.
- Faure, A., Reynolds, S.M., Richard, J.M., Berridge, K.C., 2008. Mesolimbic dopamine in desire and dread: enabling motivation to be generated by localized glutamate disruptions in nucleus accumbens. *J. Neurosci.* 28, 7184–7192.
- Federenko, I., Wust, S., Hellhammer, D.H., Dechoux, R., Kumsta, R., Kirschbaum, C., 2004. Free cortisol awakening responses are influenced by awakening time. *Psychoneuroendocrinology* 29, 174–184.
- Fehmi, L.G., Shor, S.B., 2013. Open focus attention training. *Psychiatr. Clin. North Am.* 36, 153–162.
- Feldman Barrett, L., Russell, J.A., 1999. The structure of current affect: controversies and emerging consensus. *Curr. Directions Psychol. Sci.* 8, 10–14.
- Feldman, R., 2007a. Mother–infant synchrony and the development of moral orientation in childhood and adolescence: direct and indirect mechanisms of developmental continuity. *Am. J. Orthopsychiatry* 77, 582–597.
- Feldman, R., 2007b. Parent–infant synchrony and the construction of shared timing: physiological precursors, developmental outcomes, and risk conditions. *J. Child Psychol. Psychiatry* 48, 329–354.
- Feldman, R., 2012. Parent–infant synchrony: a biobehavioral model of mutual influences in the formation of affiliative bonds. *Monogr. Soc. Res. Child Dev.* 77, 42–51.
- Fellinger, R., Klimesch, W., Schnakers, C., Perrin, F., Freunberger, R., Gruber, W., Laureys, S., Schabus, M., 2011. Cognitive processes in disorders of consciousness as revealed by EEG time–frequency analyses. *Clin. Neurophysiol.* 122, 2177–2184.
- Ferini-Strambi, L., Oertel, W., Dauvilliers, Y., Postuma, R.B., Marelli, S., Iranzo, A., Arnulf, I., Hogl, B., Manni, R., Miyamoto, T., Fantini, M.L., Puligheddu, M., Jennum, P., Sonka, K., Santamaria, J., Zucconi, M., Rancoita, P.M., Leu-Semenescu, S., Frauscher, B., Terzaghi, M., Miyamoto, M., Unger, M., Stiasny-Kolster, K., Desautels, A., Wolfson, C., Pelletier, A., Montplaisir, J., 2014. Autonomic symptoms in idiopathic REM behavior disorder: a multicentre case–control study. *J. Neurol.* 261, 1112–1118.
- Ferri, F., Ardizzi, M., Ambrosecchia, M., Gallese, V., 2013. Closing the gap between the inside and the outside: interoceptive sensitivity and social distances. *PLoS ONE* 8, e75758.
- Fiacconi, C.M., Owen, A.M., 2016. Using facial electromyography to detect preserved emotional processing in disorders of consciousness: a proof-of-principle study. *Clin. Neurophysiol.* 127, 3000–3006.
- Fiddler, M., Jackson, J., Kapur, N., Wells, A., Creed, F., 2004. Childhood adversity and frequent medical consultations. *Gen. Hosp. Psychiatry* 26, 367–377.
- Finan, P.H., Goodin, B.R., Smith, M.T., 2013. The association of sleep and pain: an update and a path forward. *J. Pain* 14, 1539–1552.
- Fisher, C., Byrne, J., Edwards, A., Kahn, E., 1970. A psychophysiological study of nightmares. *J. Am. Psychoanal. Assoc.* 18, 747–782.
- Fisher, C., Kahn, E., Edwards, A., Davis, D.M., 1973. A psychophysiological study of nightmares and night terrors. I. Physiological aspects of the stage 4 night terror. *J. Nerv. Ment. Dis.* 157, 75–98.
- Folkersma, H., Boellaard, R., Yaqub, M., Kloet, R.W., Windhorst, A.D., Lammertsma, A.A., Vandertop, W.P., van Berckel, B.N., 2011. Widespread and prolonged increase in (R)-[11C]-PK11195 binding after traumatic brain injury. *J. Nucl. Med.* 52, 1235–1239.
- Fontaine, J.R., Scherer, K.R., Roesch, E.B., Ellsworth, P.C., 2007. The world of emotions is not two-dimensional. *Psychol. Sci.* 18, 1050–1057.
- Fortin VI, A.H., Dwamena, F., Frankel, R., Lepisto, B., Smith, R., 2018. *Smith's Patient-Centered Interviewing – An Evidence-Based Method*, 4th ed. McGraw-Hill, New York Lange Series.
- Fosse, R., Stickgold, R., Hobson, J.A., 2001. The mind in REM sleep: reports of emotional experience. *Sleep* 24, 947–955.
- Foti, D., Hajcak, G., 2009. Depression and reduced sensitivity to non-rewards versus rewards: evidence from event-related potentials. *Biol. Psychol.* 81, 1–8.
- Foti, D., Kotov, R., Klein, D.N., Hajcak, G., 2011. Abnormal neural sensitivity to monetary gains versus losses among adolescents at risk for depression. *J. Abnorm. Child Psychol.* 39, 913–924.
- Foti, D., Weinberg, A., Bernat, E.M., Proudfit, G.H., 2015. Anterior cingulate activity to monetary loss and basal ganglia activity to monetary gain uniquely contribute to the feedback negativity. *Clin. Neurophysiol.* 126, 1338–1347.
- Foulkes, D., Sullivan, B., Kerr, N., Brown, L., 1988. Appropriateness of dream feelings to dreamed situations. *Cogn. Emotion* 2, 29–39.
- Fowles, D.C., 1994. *A Motivational Theory of Psychopathology*. University of Nebraska Press, Lincoln, NE.
- Frank, D.W., Dewitt, M., Hudgens-Haney, M., Schaeffer, D.J., Ball, B.H., Schwarz, N.F., Husseini, A.A., Smart, L.M., Sabatinelli, D., 2014. Emotion regulation: quantitative meta-analysis of functional activation and deactivation. *Neurosci. Biobehav. Rev.* 45, 202–211.
- Fransson, P., Merboldt, K.D., Petersson, K.M., Ingvar, M., Frahm, J., 2002. On the effects of spatial filtering – a comparative fMRI study of episodic memory encoding at high and low resolution. *Neuroimage* 16, 977–984.
- Frauscher, B., Nomura, T., Duerr, S., Ehrmann, L., Gschliesser, V., Wenning, G.K., Wolf, E., Inoue, Y., Hogl, B., Poewe, W., 2012. Investigation of autonomic function in idiopathic REM sleep behavior disorder. *J. Neurol.* 259, 1056–1061.
- Frewen, P.A., Lundberg, E., Brimson-Theberge, M., Theberge, J., 2013. Neuroimaging self-esteem: a fMRI study of individual differences in women. *Soc. Cogn. Affect. Neurosci.* 8, 546–555.
- Friedman, B.H., 2010. Feelings and the body: the Jamesian perspective on autonomic specificity of emotion. *Biol. Psychol.* 84, 383–393.
- Friedman, B.H., Thayer, J.F., 2018. *Is emotion physiology more compatible with discrete, dimensional or appraisal accounts? An historical overview and dynamic systems perspective (submitted for publication)*.
- Frijda, N.H., 1986. *The Emotions*. Cambridge University Press, Cambridge.
- Frijda, N.H., 2009. Emotion experience and its varieties. *Emotion Rev.* 1, 264–271.
- Frijda, N.H., Kuipers, P., TerSchure, E., 1989. Relations among emotion, appraisal, and emotional action readiness. *J. Pers. Soc. Psychol.* 57, 212–228.
- Fukushima, H., Terasawa, Y., Umeda, S., 2011. Association between interoception and empathy: evidence from heartbeat-evoked brain potential. *Int. J. Psychophysiol.* 79, 259–265.
- Funkenstein, D.H., 1955. The physiology of fear and anger. *Sci. Am.* 192, 74–80.
- Galati, D., Scherer, K.R., Ricci-Bitti, P.E., 1997. Voluntary facial expression of emotion: comparing congenitally blind with normally sighted encoders. *J. Pers. Soc. Psychol.* 73, 1363–1379.
- Garcia-Hernandez, N., Garza-Martinez, K., Parra-Vega, V., 2018. Electromyography bio-feedback exergames to enhance grip strength and motivation. *Games Health J.* 7, 75–82.
- Gardiner, M.F., 2015. Integration of cognition and emotion in physical and mental actions in musical and other behaviors. *Behav. Brain Sci.* 38, e76.
- Garfinkel, S.N., Critchley, H.D., 2013. Interoception, emotion and brain: new insights link internal physiology to social behaviour. Commentary on: “Anterior insular cortex mediates bodily sensibility and social anxiety” by Terasawa et al. (2012). *Soc. Cogn. Affect. Neurosci.* 8, 231–234.
- Garfinkel, S.N., Critchley, H.D., 2016. Threat and the body: how the heart supports fear processing. *Trends Cogn. Sci.* 20, 34–46.
- Garfinkel, S.N., Critchley, H.D., Pollatos, O., 2016a. The interoceptive system: implications for cognition, emotion, and health. In: Cacioppo, J.T., Tassinari, L.G., Bernston, G.G. (Eds.), *Handbook of Psychophysiology*, 4th ed. Cambridge University Press, Cambridge.
- Garfinkel, S.N., Manassei, M.F., Hamilton-Fletcher, G., In den Bosch, Y., Critchley, H.D., Engels, M., 2016b. Interoceptive dimensions across cardiac and respiratory axes. *Philos. Trans. R. Soc. Lond. B: Biol. Sci.* 371.
- Garfinkel, S.N., Minati, L., Gray, M.A., Seth, A.K., Dolan, R.J., Critchley, H.D., 2014. Fear from the heart: sensitivity to fear stimuli depends on individual heartbeats. *J. Neurosci.* 34, 6573–6582.
- George, O., Le Moal, M., Koob, G.F., 2012. Allostasis and addiction: role of the dopamine and corticotropin-releasing factor systems. *Physiol. Behav.* 106, 58–64.
- Gerhardt, A., 2016. TSPO imaging in Parkinsonian disorders. *Clin. Transl. Imag.* 4, 183–190.
- Giacino, J.T., Ashwal, S., Childs, N., Cranford, R., Jennett, B., Katz, D.I., Kelly, J.P., Rosenberg, J.H., Whyte, J., Zafonte, R.D., Zasler, N.D., 2002. The minimally conscious state: definition and diagnostic criteria. *Neurology* 58, 349–353.
- Gianaros, P.J., Van Der Veen, F.M., Jennings, J.R., 2004. Regional cerebral blood flow correlates with heart period and high-frequency heart period variability during working-memory tasks: implications for the cortical and subcortical regulation of cardiac autonomic activity. *Psychophysiology* 41, 521–530.
- Gianino, A., Tronick, E.Z., 1988. The mutual regulation model: the infant's self and interactive regulation and coping and defensive capacities. In: Field, T., McCabe, P., Schneiderman, N. (Eds.), *Stress and Coping across Development*. Lawrence Erlbaum



- Associates Inc., Hillsdale, NJ, pp. 47–68.
- Gilam, G., Hendlar, T., 2016. With love, from me to you: embedding social interactions in affective neuroscience. *Neurosci. Biobehav. Rev.* 68, 590–601.
- Gilbert, K.E., Nolen-Hoeksema, S., Gruber, J., 2013. Positive emotion dysregulation across mood disorders: how amplifying versus dampening predicts emotional reactivity and illness course. *Behav. Res. Ther.* 51, 736–741.
- Glazer, J.E., Kelley, N.J., Pornpattananangkul, N., Mittal, V.A., Nusslock, R., 2018. Beyond the FRN: broadening the time-course of EEG and ERP components implicated in reward processing. *Int. J. Psychophysiol.* 132, 184–202.
- Glimcher, P.W., 2011. Understanding dopamine and reinforcement learning: the dopamine reward prediction error hypothesis. *Proc. Natl. Acad. Sci. U.S.A.* 108 (Suppl. 3), 15647–15654.
- Glover, E.M., Jovanovic, T., Mercer, K.B., Kerley, K., Bradley, B., Ressler, K.J., Norrholm, S.D., 2012. Estrogen levels are associated with extinction deficits in women with posttraumatic stress disorder. *Biol. Psychiatry* 72, 19–24.
- Glover, E.M., Mercer, K.B., Norrholm, S.D., Davis, M., Duncan, E., Bradley, B., Ressler, K.J., Jovanovic, T., 2013. Inhibition of fear is differentially associated with cycling estrogen levels in women. *J. Psychiatry Neurosci.* 38, 341–348.
- Goehler, L.E., Gaykema, R.P., Hansen, M.K., Anderson, K., Maier, S.F., Watkins, L.R., 2000. Vagal immune-to-brain communication: a visceral chemosensory pathway. *Auton. Neurosci.* 85, 49–59.
- Goehler, L.E., Lyte, M., Gaykema, R.P., 2007. Infection-induced viscerosensory signals from the gut enhance anxiety: implications for psychoneuroimmunology. *Brain. Behav. Immun.* 21, 721–726.
- Goldin, P.R., McRae, K., Gross, J.J., 2008. The neural bases of emotion regulation: reappraisal and suppression of negative emotion. *Biol. Psychiatry* 63, 577–586.
- Goldsmith, H.H., Pollak, S.D., Davidson, R.J., 2008. Developmental neuroscience perspectives on emotion regulation. *Child Dev. Perspect.* 2, 132–140.
- Goldstein, A.N., Walker, M.P., 2014. The role of sleep in emotional brain function. *Annu. Rev. Clin. Psychol.* 10, 679–708.
- Goldstein, R.Z., Cottone, L.A., Jia, Z., Maloney, T., Volkow, N.D., Squires, N.K., 2006. The effect of graded monetary reward on cognitive event-related potentials and behavior in young healthy adults. *Int. J. Psychophysiol.* 62, 272–279.
- Goldstein, R.Z., Volkow, N.D., 2002. Drug addiction and its underlying neurobiological basis: neuroimaging evidence for the involvement of the frontal cortex. *Am. J. Psychiatry* 159, 1642–1652.
- Gomez, C.M., Flores, A., Ledesma, A., 2007. Fronto-parietal networks activation during the contingent negative variation period. *Brain Res. Bull.* 73, 40–47.
- Gray, J.A., 1981. A critique of Eysenck's theory of personality. In: Eysenck, H.J. (Ed.), *A Model for Personality*. Springer-Verlag, Berlin, pp. 246–276.
- Gray, J.A., McNaughton, N., 2000. *The Neuropsychology of Anxiety*, 2nd ed. Oxford University Press, New York City, NY.
- Gray, M.A., Critchley, H.D., 2007. Interceptive basis to craving. *Neuron* 54, 183–186.
- Grissom, N., Bhatnagar, S., 2009. Habituation to repeated stress: get used to it. *Neurobiol. Learn. Mem.* 92, 215–224.
- Gross, J.J., 1998a. Antecedent- and response-focused emotion regulation: divergent consequences for experience, expression, and physiology. *J. Pers. Soc. Psychol.* 74, 224–237.
- Gross, J.J., 1998b. The emerging field of emotion regulation: an integrative review. *Rev. Gen. Psychol.* 2, 271–299.
- Gross, J.J., 2007. *Handbook of Emotion Regulation*. Guilford Press.
- Gross, J.J., Richards, J.M., John, O.P., 2006. Emotion regulation in everyday life. In: Snyder, D.K., Simpson, J., Hughes, J.N. (Eds.), *Emotion Regulation in Couples and Families: Pathways to Dysfunction and Health*. Guilford Press, New York, pp. 13–35.
- Grynberg, D., Pollatos, O., 2015. Perceiving one's body shapes empathy. *Physiol. Behav.* 140, 54–60.
- Gur, R.C., Skolnick, B.E., Gur, R.E., 1994. Effects of emotional discrimination tasks on cerebral blood flow: regional activation and its relation to performance. *Brain Cogn.* 25, 271–286.
- Haack, M., Lee, E., Cohen, D.A., Mullington, J.M., 2009a. Activation of the prostaglandin system in response to sleep loss in healthy humans: potential mediator of increased spontaneous pain. *Pain* 145, 136–141.
- Haack, M., Mullington, J.M., 2005. Sustained sleep restriction reduces emotional and physical well-being. *Pain* 119, 56–64.
- Haack, M., Sanchez, E., Mullington, J.M., 2007. Elevated inflammatory markers in response to prolonged sleep restriction are associated with increased pain experience in healthy volunteers. *Sleep* 30, 1145–1152.
- Haack, M., Scott-Sutherland, J., Sethna, N., Mullington, J.M., 2009b. Mechanisms of sleep loss-pain interactions. In: Lavigne, G., Cistulli, P.A., Smith, M.T. (Eds.), *Sleep Medicine for Dentists. A Practical Overview*. Quintessence Publishing Co., Hanover Park, IL, pp. 155–160.
- Haapakoski, R., Mathieu, J., Ebmeier, K.P., Alenius, H., Kivimaki, M., 2015. Cumulative meta-analysis of interleukins 6 and 1beta, tumour necrosis factor alpha and C-reactive protein in patients with major depressive disorder. *Brain. Behav. Immun.* 49, 206–215.
- Hagemann, D., Waldstein, S.R., Thayer, J.F., 2003. Central and autonomic nervous system integration in emotion. *Brain Cogn.* 52, 79–87.
- Hajcak, G., MacNamara, A., Olvet, D.M., 2010. Event-related potentials, emotion, and emotion regulation: an integrative review. *Dev. Neuropsychol.* 35, 129–155.
- Hajcak, G., Moser, J.S., Holroyd, C.B., Simons, R.F., 2007. It's worse than you thought: the feedback negativity and violations of reward prediction in gambling tasks. *Psychophysiology* 44, 905–912.
- Hajcak, G., Nieuwenhuis, S., 2006. Reappraisal modulates the electrocortical response to unpleasant pictures. *Cogn. Affect. Behav. Neurosci.* 6, 291–297.
- Handford, C., Lemon, J., Grimm, M.C., Vollmer-Conna, U., 2013. Empathy as a function of clinical exposure – reading emotion in the eyes. *PLoS ONE* 8, e65159.
- Hannestad, J., DellaGioia, N., Ortiz, N., Pittman, B., Bhagwagar, Z., 2011. Citalopram reduces endotoxin-induced fatigue. *Brain. Behav. Immun.* 25, 256–259.
- Hantsoo, L., Epperson, C.N., 2015. Premenstrual dysphoric disorder: epidemiology and treatment. *Curr. Psychiatry Rep.* 17, 87.
- Harmon-Jones, C., Bastian, B., Harmon-Jones, E., 2016. The Discrete Emotions Questionnaire: a new tool for measuring state self-reported emotions. *PLoS ONE* 11, e0159915.
- Harmon-Jones, E., 2003. Anger and the behavioral approach system. *Personal. Individual Diff.* 35, 995–1005.
- Harmon-Jones, E., Allen, J.J., 1997. Behavioral activation sensitivity and resting frontal EEG asymmetry: covariation of putative indicators related to risk for mood disorders. *J. Abnorm. Psychol.* 106, 159–163.
- Harmon-Jones, E., Allen, J.J., 1998. Anger and frontal brain activity: EEG asymmetry consistent with approach motivation despite negative affective valence. *J. Pers. Soc. Psychol.* 74, 1310–1316.
- Harmon-Jones, E., Gable, P.A., Price, T.F., 2013. Does negative affect always narrow and positive affect always broaden the mind? Considering the influence of motivational intensity on cognitive scope. *Curr. Directions Psychol. Sci.* 22, 301–307.
- Harmon-Jones, E., Harmon-Jones, C., Summerell, E., 2017. On the importance of both dimensional and discrete models of emotion. *Behav. Sci.* 7.
- Harrison, N.A., 2017. Brain structures implicated in inflammation-associated depression. *Curr. Top. Behav. Neurosci.* 31, 221–248.
- Harrison, N.A., Brydon, L., Walker, C., Gray, M.A., Steptoe, A., Dolan, R.J., Critchley, H.D., 2009. Neural origins of human sickness in interoceptive responses to inflammation. *Biol. Psychiatry* 66, 415–422.
- Harrison, N.A., Gray, M.A., Gianaros, P.J., Critchley, H.D., 2010. The embodiment of emotional feelings in the brain. *J. Neurosci.* 30, 12878–12884.
- Harshaw, C., 2015. Interoceptive dysfunction: toward an integrated framework for understanding somatic and affective disturbance in depression. *Psychol. Bull.* 141, 311–363.
- Heilman, R.M., Crisan, L.G., Houser, D., Miclea, M., Miu, A.C., 2010. Emotion regulation and decision making under risk and uncertainty. *Emotion (Washington, DC)* 10, 257–265.
- Heine, L., Castro, M., Martial, C., Tillmann, B., Laureys, S., Perrin, F., 2015. Exploration of functional connectivity during preferred music stimulation in patients with disorders of consciousness. *Front. Psychol.* 6, 1704.
- Heinrichs, S.C., Koob, G.F., 2004. Corticotropin-releasing factor in brain: a role in activation, arousal, and affect regulation. *J. Pharmacol. Exp. Ther.* 311, 427–440.
- Heller, W., Nitschke, J.B., 1997. Regional brain activity in emotion: a framework for understanding cognition in depression. *Cogn. Emotion* 11, 637–661.
- Helm, J.L., Sbarra, D.A., Ferrer, E., 2014. Coregulation of respiratory sinus arrhythmia in adult romantic partners. *Emotion (Washington, DC)* 14, 522–531.
- Herbert, B.M., Herbert, C., Pollatos, O., 2011. On the relationship between interoceptive awareness and alexithymia: is interoceptive awareness related to emotional awareness? *J. Pers.* 79, 1149–1175.
- Herbert, B.M., Pollatos, O., Schandry, R., 2007. Interoceptive sensitivity and emotion processing: an EEG study. *Int. J. Psychophysiol.* 65, 214–227.
- Herman, J.P., Ostrander, M.M., Mueller, N.K., Figueiredo, H., 2005. Limbic system mechanisms of stress regulation: hypothalamic-pituitary-adrenocortical axis. *Prog. Neuropsychopharmacol. Biol. Psychiatry* 29, 1201–1213.
- Hermans, D., Craske, M.G., Mineka, S., Lovibond, P.F., 2006. Extinction in human fear conditioning. *Biol. Psychiatry* 60, 361–368.
- Hermans, E.J., van Marle, H.J., Ossewaarde, L., Henckens, M.J., Qin, S., van Kesteren, M.T., Schoots, V.C., Cousijn, H., Rijpkema, M., Oostenveld, R., Fernandez, G., 2011. Stress-related noradrenergic activity prompts large-scale neural network re-configuration. *Science* 334, 1151–1153.
- Hernandez, L., Hoebel, B.G., 1988. Feeding and hypothalamic stimulation increase dopamine turnover in the accumbens. *Physiol. Behav.* 44, 599–606.
- Heuer, F., Reisberg, D., 1990. Vivid memories of emotional events: the accuracy of remembered minutiae. *Mem. Cogn.* 18, 496–506.
- Higgins, E.T., Pittman, T.S., 2008. Motives of the human animal: comprehending, managing, and sharing inner states. *Annu. Rev. Psychol.* 59, 361–385.
- Hinrichs, R., Michopoulos, V., Winters, S., Rothbaum, A.O., Rothbaum, B.O., Ressler, K.J., Jovanovic, T., 2017. Mobile assessment of heightened skin conductance in post-traumatic stress disorder. *Depress. Anxiety* 34, 502–507.
- Hobson, J.A., Friston, K.J., 2012. Waking and dreaming consciousness: neurobiological and functional considerations. *Prog. Neurobiol.* 98, 82–98.
- Hobson, J.A., Hong, C.C., Friston, K.J., 2014. Virtual reality and consciousness inference in dreaming. *Front. Psychol.* 5, 1133.
- Hobson, J.A., Pace-Schott, E.F., Stickgold, R., 2000. Dreaming and the brain: toward a cognitive neuroscience of conscious states. *Behav. Brain Sci.* 23, 793–842 discussion 904–1121.
- Hofmann, S.G., Gschwendner, T., Friese, M., Wiers, R.W., Schmitt, M., 2008. Working memory capacity and self-regulatory behavior: toward an individual differences perspective on behavior determination by automatic versus controlled processes. *J. Pers. Soc. Psychol.* 95, 962–977.
- Holland, A.C., Kensinger, E.A., 2010. Emotion and autobiographical memory. *Phys. Life Rev.* 7, 88–131.
- Holmes, S.E., Hinz, R., Conen, S., Gregory, C.J., Matthews, J.C., Anton-Rodriguez, J.M., Gerhard, A., Talbot, P.S., 2018. Elevated translocator protein in anterior cingulate in major depression and a role for inflammation in suicidal thinking: a positron emission tomography study. *Biol. Psychiatry* 83, 61–69.
- Holroyd, C.B., Nieuwenhuis, S., Yeung, N., Cohen, J.D., 2003. Errors in reward prediction are reflected in the event-related brain potential. *Neuroreport* 14, 2481–2484.
- Holzel, B.K., Carmody, J., Vangel, M., Congleton, C., Yerramsetti, S.M., Gard, T., Lazar, S.W., 2011. Mindfulness practice leads to increases in regional brain gray matter density. *Psychiatry Res.* 191, 36–43.
- Hot, P., Leconte, P., Sequeira, H., 2005. Diurnal autonomic variations and emotional reactivity. *Biol. Psychol.* 69, 261–270.
- Hurlmann, R., Scheele, D., 2016. Dissecting the role of oxytocin in the formation and loss of social relationships. *Biol. Psychiatry* 79, 185–193.
- Hutchison, I.C., Rathore, S., 2015. The role of REM sleep theta activity in emotional memory. *Front. Psychol.* 6, 1439.
- Hwang, M.J., Zsido, R.G., Song, H., Pace-Schott, E.F., Miller, K.K., Lebron-Milad, K.,



- Marin, M.-F., Milad, M.R., 2015. Contribution of estradiol levels and hormonal contraceptives to sex differences within the fear network during fear conditioning and extinction. *BMC Psychiatry* 15, 295.
- Iacoboni, M., 2009. Imitation, empathy, and mirror neurons. *Annu. Rev. Psychol.* 60, 653–670.
- Immordino-Yang, M.H., Yang, X.F., Damasio, H., 2014. Correlations between social-emotional feelings and anterior insula activity are independent from visceral states but influenced by culture. *Front. hum. neurosci.* 8, 728.
- Irwin, M.R., Olmstead, R., Carroll, J.E., 2016. Sleep disturbance, sleep duration, and inflammation: a systematic review and meta-analysis of cohort studies and experimental sleep deprivation. *Biol. Psychiatry* 80, 40–52.
- Izard, C.E., 1971. *The Face of Emotion*. Appleton-Century-Crofts, New York.
- Izard, C.E., 1994. Innate and universal facial expressions: evidence from developmental and cross-cultural research. *Psychol. Bull.* 115, 288–299.
- Izard, C.E., 2007. Basic emotions, natural kinds, emotion schemas, and a new paradigm. *Perspect. Psychol. Sci.* 2, 260–280.
- Izard, C.E., 2010. The many meanings/aspects of emotion: definitions, functions, activation, and regulation. *Emotion Rev.* 2, 363–370.
- Izard, C.E., Huebner, R.R., Risser, D., Dougherty, L., 1980. The young infant's ability to produce discrete emotion expressions. *Dev. Psychol.* 16, 132–140.
- James, W., 1884. What is an emotion. *Mind* 19, 188–205.
- Janig, W., Habler, H.J., 2000. Sympathetic nervous system: contribution to chronic pain. *Prog. Brain Res.* 129, 451–468.
- Jenkinson, P.M., Taylor, L., Laws, K.R., 2018. Self-reported interoceptive deficits in eating disorders: a meta-analysis of studies using the eating disorder inventory. *J. Psychosom. Res.* 110, 38–45.
- Jessen, N.A., Munk, A.S., Lundgaard, I., Nedergaard, M., 2015. The glymphatic system: a beginner's guide. *Neurochem. Res.* 40, 2583–2599.
- Ji, R.R., Chamesian, A., Zhang, Y.Q., 2016. Pain regulation by non-neuronal cells and inflammation. *Science* 354, 572–577.
- John, O.P., Gross, J.J., 2004. Healthy and unhealthy emotion regulation: personality processes, individual differences, and life span development. *J. Pers.* 72, 1301–1333.
- Johnson, Z.V., Young, L.J., 2017. Oxytocin and vasopressin neural networks: implications for social behavioral diversity and translational neuroscience. *Neurosci. Biobehav. Rev.* 76, 87–98.
- Johnstone, T., Ores Walsh, K.S., Greischar, L.L., Alexander, A.L., Fox, A.S., Davidson, R.J., Oakes, T.R., 2006. Motion correction and the use of motion covariates in multiple-subject fMRI analysis. *Hum. Brain Mapp.* 27, 779–788.
- Jonassen, R., Landro, N.L., 2014. Serotonin transporter polymorphisms (5-HTTLPR) in emotion processing: implications from current neurobiology. *Prog. Neurobiol.* 117, 41–53.
- Joshi, M.S., Carter, W., 2013. Unrealistic optimism: east and west? *Front. Psychol.* 4, 6.
- Jovanovic, T., Keyes, M., Fiallos, A., Myers, K.M., Davis, M., Duncan, E.J., 2005. Fear potentiation and fear inhibition in a human fear-potentiated startle paradigm. *Biol. Psychiatry* 57, 1559–1564.
- Jovanovic, T., Norrholm, S.D., Blanding, N.Q., Davis, M., Duncan, E., Bradley, B., Ressler, K.J., 2010. Impaired fear inhibition is a biomarker of PTSD but not depression. *Depress. Anxiety* 27, 244–251.
- Jovanovic, T., Rauch, S.A.M., Rothbaum, A.O., Rothbaum, B.O., 2017. Using experimental methodologies to assess posttraumatic stress. *Curr. Opin. Psychol.* 14, 23–28.
- Junghofer, M., Bradley, M.M., Elbert, T.R., Lang, P.J., 2001. Fleeting images: a new look at early emotion discrimination. *Psychophysiology* 38, 175–178.
- Junghofer, M., Schupp, H., Stark, R., Schienle, A., Elbert, T., Hamm, A., Vaitl, D., 2002. Valence, arousal, and selective picture processing: an fMRI analysis. *Psychophysiology* 39, S14–S15.
- Juster, R.P., Bizik, G., Picard, M., Arsenault-Lapierre, G., Sindi, S., Trepanier, L., Marin, M.F., Wan, N., Sekerovic, Z., Lord, C., Fiocco, A.J., Plusquellec, P., McEwen, B.S., Lupien, S.J., 2011. A transdisciplinary perspective of chronic stress in relation to psychopathology throughout life span development. *Dev. Psychopathol.* 23, 725–776.
- Kabat-Zinn, 1990. *Full Catastrophe Living: Using the Wisdom of Your Body and Mind to Face Stress, Pain, and Illness*. Dell Publishing, New York.
- Kahn, M., Sheppes, G., Sadeh, A., 2013. Sleep and emotions: bidirectional links and underlying mechanisms. *Int. J. Psychophysiol.* 89, 218–228.
- Kalsbeek, A., van der Spek, R., Lei, J., Ender, E., Buijs, R.M., Fliers, E., 2012. Circadian rhythms in the hypothalamo-pituitary-adrenal (HPA) axis. *Mol. Cell. Endocrinol.* 349, 20–29.
- Kandasamy, N., Garfinkel, S.N., Page, L., Hardy, B., Critchley, H.D., Gurnell, M., Coates, J.M., 2016. Interoceptive ability predicts survival on a london trading floor. *Sci. Rep.* 6, 32986.
- Kanske, P., Bockler, A., Trautwein, F.M., Singer, T., 2015. Dissecting the social brain: introducing the EmpaToM to reveal distinct neural networks and brain-behavior relations for empathy and theory of mind. *Neuroimage* 122, 6–19.
- Kaplan, R.L., Levine, L.J., Lench, H.C., Safer, M.A., 2016. Forgetting feelings: opposite biases in reports of the intensity of past emotion and mood. *Emotion (Washington, DC)* 16, 309–319.
- Kappas, A., 2011. Emotion and regulation are one! *Emotion Rev.* 3, 17–25.
- Kelley, K.W., Bluthé, R.M., Dantzer, R., Zhou, J.H., Shen, W.H., Johnson, R.W., Broussard, S.R., 2003. Cytokine-induced sickness behavior. *Brain. Behav. Immun.* 17 (Suppl. 1), S112–S118.
- Keltner, D., 1995. The signs of appeasement: evidence for the distinct displays of embarrassment, amusement, and shame. *J. Pers. Soc. Psychol.* 68, 441–454.
- Keltner, D., Anderson, C., 2000. Saving face for Darwin: functions and uses of embarrassment. *Curr. Directions Psychol. Sci.* 9, 187–191.
- Keltner, D., Buswell, B.N., 1997. Embarrassment: its distinct form and appeasement functions. *Psychol. Bull.* 122, 250–270.
- Kemp, A.H., Quintana, D.S., Gray, M.A., Felmingham, K.L., Brown, K., Gatt, J.M., 2010. Impact of depression and antidepressant treatment on heart rate variability: a review and meta-analysis. *Biol. Psychiatry* 67, 1067–1074.
- Ketchesin, K.D., Stinnett, G.S., Seasholtz, A.F., 2017. Corticotropin-releasing hormone-binding protein and stress: from invertebrates to humans. *Stress* 20, 449–464.
- Khalsa, S.S., Adolphs, R., Cameron, O.G., Critchley, H.D., Davenport, P.W., Feinstein, J.S., Feusner, J.D., Garfinkel, S.N., Lane, R.D., Mehling, W.E., Meuret, A.E., Nemeroff, C.B., Oppenheimer, S., Petzschner, F.H., Pollatos, O., Rhudy, J.L., Schramm, L.P., Simmons, W.K., Stein, M.B., Stephan, K.E., Van Den Bergh, O., Van Diest, I., von Leupoldt, A., Paulus, M.P., participants, T.I.S., 2018. Interoception and mental health: a roadmap. *Biol. Psychiatry Cogn. Neurosci. Neuroimag.*
- Khoury, B., Sharma, M., Rush, S.E., Fournier, C., 2015. Mindfulness-based stress reduction for healthy individuals: a meta-analysis. *J. Psychosom. Res.* 78, 519–528.
- Kikuchi, M., Hanaoka, A., Kidani, T., Remijn, G.B., Minabe, Y., Munose, T., Koshino, Y., 2009. Heart rate variability in drug-naive patients with panic disorder and major depressive disorder. *Prog. Neuropsychopharmacol. Biol. Psychiatry* 33, 1474–1478.
- Kilpatrick, L.A., Suyenobu, B.Y., Smith, S.R., Bueller, J.A., Goodman, T., Creswell, J.D., Tillisch, K., Mayer, E.A., Naliboff, B.D., 2011. Impact of mindfulness-based stress reduction training on intrinsic brain connectivity. *Neuroimage* 56, 290–298.
- Kirby, L.A.J., Robinson, J.L., 2017. Affective mapping: an activation likelihood estimation (ALE) meta-analysis. *Brain Cogn.* 118, 137–148.
- Kircanski, K., Lieberman, M.D., Craske, M.G., 2012. Feelings into words: contributions of language to exposure therapy. *Psychol. Sci.* 23, 1086–1091.
- Kisley, M.A., Wood, S., Burrows, C.L., 2007. Looking at the sunny side of life: age-related change in an event-related potential measure of the negativity bias. *Psychol. Sci.* 18, 838–843.
- Kleckner, I.R., Zhang, J., Touroutoglou, A., Chanes, L., Xia, C., Simmons, W.K., Quigley, K.S., Dickerson, B.C., Barrett, L.F., 2017. Evidence for a large-scale brain system supporting allostasis and interoception in humans. *Nat. Hum. Behav.* 1.
- Kleinsmith, L.J., Kaplan, S., 1963. Paired-associate learning as a function of arousal and interpolated interval. *J. Exp. Psychol.* 65, 190–193.
- Kling, M.A., DeBellis, M.D., O'Rourke, D.K., Listwak, S.J., Geraciotti Jr., T.D., McCutcheon, L.E., Kalogeras, K.T., Oldfield, E.H., Gold, P.W., 1994. Diurnal variation of cerebrospinal fluid immunoreactive corticotropin-releasing hormone levels in healthy volunteers. *J. Clin. Endocrinol. Metab.* 79, 233–239.
- Kober, H., Barrett, L.F., Joseph, J., Bliss-Moreau, E., Lindquist, K., Wager, T.D., 2008. Functional grouping and cortical-subcortical interactions in emotion: a meta-analysis of neuroimaging studies. *Neuroimage* 42, 998–1031.
- Kober, H., Kross, E.F., Mischel, W., Hart, C.L., Ochsner, K.N., 2010. Regulation of craving by cognitive strategies in cigarette smokers. *Drug Alcohol Depend.* 106, 52–55.
- Kohn, N., Eickhoff, S.B., Scheller, M., Laird, A.R., Fox, P.T., Habel, U., 2014. Neural networks of cognitive emotion regulation – an ALE meta-analysis and MACM analysis. *Neuroimage* 87, 345–355.
- Koob, G.F., 2013. Theoretical frameworks and mechanistic aspects of alcohol addiction: alcohol addiction as a reward deficit disorder. *Curr. Top. Behav. Neurosci.* 13, 3–30.
- Kotchoubey, B., Pavlov, Y.G., Kleber, B., 2015. Music in research and rehabilitation of disorders of consciousness: psychological and neurophysiological foundations. *Front. Psychol.* 6, 1763.
- Koteles, F., Witthoft, M., 2017. Somatosensory amplification – an old construct from a new perspective. *J. Psychosom. Res.* 101, 1–9.
- Kotynski, A.E., Demaree, H.A., 2017. A study named desire: local focus increases approach motivation for desserts. *Motivation Emotion* 41, 455–464.
- Kozłowska, K., Walker, P., McLean, L., Carrive, P., 2015. Fear and the defense cascade: clinical implications and management. *Harv. Rev. Psychiatry* 23, 263–287.
- Kragel, P.A., Labar, K.S., 2013. Multivariate pattern classification reveals autonomic and experiential representations of discrete emotions. *Emotion (Washington, DC)* 13, 681–690.
- Krautwurst, S., Gerlach, A.L., Gomille, L., Hiller, W., Witthoft, M., 2014. Health anxiety – an indicator of higher interoceptive sensitivity? *J. Behav. Ther. Exp. Psychiatry* 45, 303–309.
- Krautwurst, S., Gerlach, A.L., Witthoft, M., 2016. Interoception in pathological health anxiety. *J. Abnorm. Psychol.* 125, 1179–1184.
- Kreibitz, S.D., 2010. Autonomic nervous system activity in emotion: a review. *Biol. Psychol.* 84, 394–421.
- Kreis, W.C., Lyoo, C.H., Liow, J.S., Wei, M., Snow, J., Page, E., Jenko, K.J., Morse, C.L., Zoghbi, S.S., Pike, V.W., Turner, R.S., Innis, R.B., 2016. (11)C-PBR28 binding to translocator protein increases with progression of Alzheimer's disease. *Neurobiol. Aging* 44, 53–61.
- Kroenke, K., 2003. The interface between physical and psychological symptoms, primary care companion. *J. Clin. Psychiatry* 5, 11–18.
- Kujawa, A., Hajcak, G., Torpey, D., Kim, J., Klein, D.N., 2012. Electrocortical reactivity to emotional faces in young children and associations with maternal and paternal depression. *J. Child Psychol. Psychiatry* 53, 207–215.
- Kundermann, B., Sternal, J., Huber, M.T., Krieg, J.C., Lautenbacher, S., 2004. Sleep deprivation affects thermal pain thresholds but not somatosensory thresholds in healthy volunteers. *Psychosom. Med.* 66, 932–937.
- Kuner, R., Flor, H., 2017. Structural plasticity and reorganisation in chronic pain. *Nat. Rev.* 18, 113.
- Kuo, M.F., Nitsche, M.A., 2015. Exploring prefrontal cortex functions in healthy humans by transcranial electrical stimulation. *Neurosci. Bull.* 31, 198–206.
- Kurth, S., Ringli, M., Geiger, A., LeBourgeois, M., Jenni, O.G., Huber, R., 2010. Mapping of cortical activity in the first two decades of life: a high-density sleep electroencephalogram study. *J. Neurosci.* 30, 13211–13219.
- Lang, P.J., 1978. Anxiety: toward a psychophysiological definition. In: Akiskal, H.S., Webb, W.L. (Eds.), *Psychiatric Diagnosis: Exploration of Biological Predictors*, pp. 365–389.
- Lang, P.J., Bradley, M.M., Cuthbert, B.N., 1997. Motivated attention: affect, activation, and action. In: Lang, P.J., Simons, R.F., Balaban, M.T. (Eds.), *Attention and Orienting: Sensory and Motivational Processes*. Lawrence Erlbaum Associates, Hillsdale, NJ, pp. 97–135.
- Lang, P.J., Davis, M., Ohman, A., 2000. Fear and anxiety: animal models and human cognitive psychophysiology. *J. Affect. Disord.* 61, 137–159.
- Lange, C., 1922. *The Emotions*. Williams & Wilkins, Baltimore, MD.
- Lange, C.G., 1885/1912. The mechanisms of the emotions. In: Rand, B. (Ed.), The

- Clausal Psychologists. Houghton Mifflin, Boston, pp. 672–684.
- Latreoliere, A., Woolf, C.J., 2009. Central sensitization: a generator of pain hypersensitivity by central neural plasticity. *J. Pain* 10, 895–926.
- Laureys, S., Celesia, G.G., Cohadon, F., Lavrijsen, J., Leon-Carrion, J., Sannita, W.G., Szobon, L., Schmutzhard, E., von Wild, K.R., Zeman, A., Dolce, G., European Task Force on Disorders of Consciousness, 2010. Unresponsive wakefulness syndrome: a new name for the vegetative state or apallic syndrome. *BMC Med.* 8, 68.
- Lautenbacher, S., Kundermann, B., Krieg, J.C., 2006. Sleep deprivation and pain perception. *Sleep Med. Rev.* 10, 357–369.
- Lazarus, R.S., 1966. *Psychological Stress and Coping Process*. McGraw-Hill, New York City, NY.
- Lazarus, R.S., Alpert, E., 1964. Short-circuiting of threat by experimentally altering cognitive appraisal. *J. Abnorm. Psychol.* 69, 195–205.
- Lazarus, R.S., Folkman, S., 1984. *Stress, Appraisal, and Coping*. Springer, New York.
- LeDoux, J., 2012. Rethinking the emotional brain. *Neuron* 73, 653–676.
- LeDoux, J., 2015. Feelings: what are they & how does the brain make them? *Dædalus J. Am. Acad. Arts Sci.* 144, 96–111.
- LeDoux, J.E., 2000. Emotion circuits in the brain. *Annu. Rev. Neurosci.* 23, 155–184.
- LeDoux, J.E., 2002. *Synaptic Self: How Our Brains Become Who We Are*. Viking, New York.
- LeDoux, J.E., Brown, R., 2017. A higher-order theory of emotional consciousness. *Proc. Natl. Acad. Sci. U.S.A.* 114, E2016–E2025.
- Lee, H., Heller, A.S., van Reekum, C.M., Nelson, B., Davidson, R.J., 2012. Amygdala-prefrontal coupling underlies individual differences in emotion regulation. *Neuroimage* 62, 1575–1581.
- LeGates, T.A., Altimus, C.M., Wang, H., Lee, H.K., Yang, S., Zhao, H., Kirkwood, A., Weber, E.T., Hattar, S., 2012. Aberrant light directly impairs mood and learning through melanopsin-expressing neurons. *Nature* 491, 594–598.
- LeGates, T.A., Fernandez, D.C., Hattar, S., 2014. Light as a central modulator of circadian rhythms, sleep and affect. *Nat. Rev.* 15, 443–454.
- Lehofer, M., Moser, M., Hoehn-Saric, R., McLeod, D., Liebmann, P., Drnovsek, B., Egner, S., Hildebrandt, G., Zapotoczky, H.G., 1997. Major depression and cardiac autonomic control. *Biol. Psychiatry* 42, 914–919.
- Lehrer, P.M., 2018. Heart rate variability biofeedback and other psychophysiological procedures as important elements in psychotherapy. *Int. J. Psychophysiol.* 131, 89–95.
- Leo, A., Naro, A., Cannavo, A., Pisani, L.R., Bruno, R., Salviera, C., Bramanti, P., Calabro, R.S., 2016. Could autonomic system assessment be helpful in disorders of consciousness diagnosis? A neurophysiological study. *Exp. Brain Res.* 234, 2189–2199.
- Lerner, J.S., Small, D.A., Loewenstein, G., 2004. Heart strings and purse strings: carryover effects of emotions on economic decisions. *Psychol. Sci.* 15, 337–341.
- Leung, A., Gregory, N.S., Allen, L.A., Sluka, K.A., 2016. Regular physical activity prevents chronic pain by altering resident muscle macrophage phenotype and increasing interleukin-10 in mice. *Pain* 157, 70–79.
- Leussis, M.P., Bolivar, V.J., 2006. Habituation in rodents: a review of behavior, neurobiology, and genetics. *Neurosci. Biobehav. Rev.* 30, 1045–1064.
- Levenson, J., 2005. *Textbook of Psychosomatic Medicine*. American Psychiatric Association Publishing Co., Inc., Washington, DC.
- Levenson, R.W., 2003. Autonomic specificity and emotion. In: Davidson, R.J., Scherer, K.R., Goldsmith, H.H. (Eds.), *Handbook of Affective Sciences*. Oxford University Press, Oxford, pp. 212–224.
- Levenson, R.W., Gottman, J.M., 1983. Marital interaction: physiological linkage and affective exchange. *J. Pers. Soc. Psychol.* 45, 587–597.
- Levesque, J., Joannette, Y., Mensour, B., Beaudoin, G., Leroux, J.M., Bourgouin, P., et al., 2004. Neural basis of emotional self-regulation in childhood. *Neuroscience* 129, 361–369.
- Levin, R., Nielsen, T.A., 2007. Disturbed dreaming, posttraumatic stress disorder, and affect distress: a review and neurocognitive model. *Psychol. Bull.* 133, 482–528.
- Levitan, R.D., 2007. The chronobiology and neurobiology of winter seasonal affective disorder. *Dialog. Clin. Neurosci.* 9, 315–324.
- Lewis, M.D., 2005. Bridging emotion theory and neurobiology through dynamic systems modeling. *Behav. Brain Sci.* 28, 169–194 discussion 194–245.
- Lewis, M.D., Lamm, C., Segalowitz, S.J., Stieben, J., Zelazo, P.D., 2006. Neurophysiological correlates of emotion regulation in children and adolescents. *J. Cogn. Neurosci.* 18, 430–443.
- Leyland, A., Rowse, G., Emerson, L.M., 2019. Experimental effects of mindfulness inductions on self-regulation: systematic review and meta-analysis. *Emotion (Washington, DC)* 19, 108–122.
- Licht, C.M., de Geus, E.J., Zitman, F.G., Hoogendijk, W.J., van Dyck, R., Penninx, B.W., 2008. Association between major depressive disorder and heart rate variability in the Netherlands Study of Depression and Anxiety (NESDA). *Arch. Gen. Psychiatry* 65, 1358–1367.
- Light, K.C., Kothandapani, R.V., Allen, M.T., 1998. Enhanced cardiovascular and catecholamine responses in women with depressive symptoms. *Int. J. Psychophysiol.* 28, 157–166.
- Ligon, C.O., Moloney, R.D., Greenwood-Van Meerveld, B., 2016. Targeting epigenetic mechanisms for chronic pain: a valid approach for the development of novel therapeutics. *J. Pharmacol. Exp. Ther.* 357, 84–93.
- Limmer, J., Kornhuber, J., Martin, A., 2015. Panic and comorbid depression and their associations with stress reactivity, interoceptive awareness and interoceptive accuracy of various bioparameters. *J. Affect. Disord.* 185, 170–179.
- Lindquist, K.A., Satpute, A.B., Wager, T.D., Weber, J., Barrett, L.F., 2016. The brain basis of positive and negative affect: evidence from a meta-analysis of the human neuroimaging literature. *Cereb. Cortex* 26, 1910–1922.
- Lindquist, K.A., Wager, T.D., Kober, H., Bliss-Moreau, E., Barrett, L.F., 2012. The brain basis of emotion: a meta-analytic review. *Behav. Brain Sci.* 35, 121–143.
- Lissek, S., Biggs, A.L., Rabin, S.J., Cornwell, B.R., Alvarez, R.P., Pine, D.S., Grillon, C., 2008. Generalization of conditioned fear-potentiated startle in humans: experimental validation and clinical relevance. *Behav. Res. Ther.* 46, 678–687.
- Liu, X., Hairston, J., Schrier, M., Fan, J., 2011. Common and distinct networks underlying reward valence and processing stages: a meta-analysis of functional neuroimaging studies. *Neurosci. Biobehav. Rev.* 35, 1219–1236.
- Luft, C.D., Bhattacharya, J., 2015. Aroused with heart: modulation of heartbeat evoked potential by arousal induction and its oscillatory correlates. *Sci. Rep.* 5, 15717.
- Lumley, M.A., Cohen, J.L., Borszcz, G.S., Cano, A., Radcliffe, A.M., Porter, L.S., Schubiner, H., Keefe, F.J., 2011. Pain and emotion: a biopsychosocial review of recent research. *J. Clin. Psychol.* 67, 942–968.
- Lupien, S.J., Parent, S., Evans, A.C., Tremblay, R.E., Zelazo, P.D., Corbo, V., Pruessner, J.C., Seguin, J.R., 2011. Larger amygdala but no change in hippocampal volume in 10-year-old children exposed to maternal depressive symptomatology since birth. *Proc. Natl. Acad. Sci. U.S.A.* 108, 14324–14329.
- Macar, F., Vidal, F., 2003. The CNV peak: an index of decision making and temporal memory. *Psychophysiology* 40, 950–954.
- Macefield, V.G., James, C., Henderson, L.A., 2013. Identification of sites of sympathetic outflow at rest and during emotional arousal: concurrent recordings of sympathetic nerve activity and fMRI of the brain. *Int. J. Psychophysiol.* 89, 451–459.
- Maclean, P.D., 1952. Some psychiatric implications of physiological studies on fronto-temporal portion of limbic system (visceral brain). *Electroencephalogr. Clin. Neurophysiol.* 4, 407–418.
- Magnusson, A., Boivin, D., 2003. Seasonal affective disorder: an overview. *Chronobiol. Int.* 20, 189–207.
- Mahowald, M.W., Cramer Bornemann, M.A., Schenck, C.H., 2011. State dissociation, human behavior, and consciousness. *Curr. Top. Med. Chem.* 11, 2392–2402.
- Maier, S.F., Goehler, L.E., Fleshner, M., Watkins, L.R., 1998. The role of the vagus nerve in cytokine-to-brain communication. *Ann. N.Y. Acad. Sci.* 840, 289–300.
- Maier, S.F., Watkins, L.R., Fleshner, M., 1994. Psychoneuroimmunology. The interface between behavior, brain, and immunity. *Am. Psychol.* 49, 1004–1017.
- Makeig, S., Debener, S., Onton, J., Delorme, A., 2004. Mining event-related brain dynamics. *Trends Cogn. Sci.* 8, 204–210.
- Manning, C.E., Williams, E.S., Robison, A.J., 2017. Reward network immediate early gene expression in mood disorders. *Front. Behav. Neurosci.* 11, 77.
- Maquet, P., Peters, J., Aerts, J., Delfiore, G., Degueldre, C., Luxen, A., Franck, G., 1996. Functional neuroanatomy of human rapid-eye-movement sleep and dreaming. *Nature* 383, 163–166.
- Maquet, P., Ruby, P., Maudoux, A., Albouy, G., Sterpenich, V., Dang-Vu, T., Desseilles, M., Boly, M., Perrin, F., Peigneux, P., Laureys, S., 2005. Human cognition during REM sleep and the activity profile within frontal and parietal cortices: a reappraisal of functional neuroimaging data. *Prog. Brain Res.* 150, 219–227.
- Marin, M.F., Lord, C., Andrews, J., Juster, R.P., Sindi, S., Arseneault-Lapierre, G., Fiocco, A.J., Lupien, S.J., 2011. Chronic stress, cognitive functioning and mental health. *Neurobiol. Learn. Mem.* 96, 583–595.
- Marin, R.S., Wilkosz, P.A., 2005. Disorders of diminished motivation. *J. Head Trauma Rehabil.* 20, 377–388.
- Mason, J.W., 1968. A review of psychoendocrine research on the pituitary–adrenal cortical system. *Psychosom. Med.* 30 (Suppl), 576–607.
- Matchett, G., Davey, G.C., 1991. A test of a disease-avoidance model of animal phobias. *Behav. Res. Ther.* 29, 91–94.
- Mather, M., Carstensen, L.L., 2003. Aging and attentional biases for emotional faces. *Psychol. Sci.* 14, 409–415.
- Matsumoto, D., Willingham, B., 2009. Spontaneous facial expressions of emotion of congenitally and noncongenitally blind individuals. *J. Pers. Soc. Psychol.* 96, 1–10.
- Mauss, I.B., Bunge, S.A., Gross, J.J., 2007a. Automatic emotion regulation. *Soc. Pers. Compass* 1, 1–22.
- Mauss, I.B., Cook, C.L., Gross, J.J., 2007b. Automatic emotion regulation during anger provocation. *J. Exp. Soc. Psychol.* 43, 698–711.
- Mauss, I.B., Robinson, M.D., 2009. Measures of emotion: a review. *Cogn. Emotion* 23, 209–237.
- Mayer, E.A., 2011. Gut feelings: the emerging biology of gut–brain communication. *Nat. Rev.* 12, 453–466.
- McClung, C.A., 2007. Role for the Clock gene in bipolar disorder. *Cold Spring Harb. Symp. Quant. Biol.* 72, 637–644.
- McClung, C.A., 2011. Circadian rhythms and mood regulation: insights from pre-clinical models. *Eur. Neuropsychopharmacol.* 21 (Suppl 4), S683–S693.
- McClung, C.A., 2013. How might circadian rhythms control mood? Let me count the ways. *Biol. Psychiatry* 74, 242–249.
- McEwen, B.S., 1998. Stress, adaptation, and disease. Allotaxis and allostatic load. *Ann. N.Y. Acad. Sci.* 840, 33–44.
- McEwen, B.S., De Kloet, E.R., Rostene, W., 1986. Adrenal steroid receptors and actions in the nervous system. *Physiol. Rev.* 66, 1121–1188.
- McEwen, B.S., Weiss, J.M., Schwartz, L.S., 1968. Selective retention of corticosterone by limbic structures in rat brain. *Nature* 220, 911–912.
- McEwen, B.S., Wingfield, J.C., 2003. The concept of allotaxis in biology and biomedicine. *Horm. Behav.* 43, 2–15.
- McGaugh, J.L., Cahill, L., Roozendaal, B., 1996. Involvement of the amygdala in memory storage: interaction with other brain systems. *Proc. Natl. Acad. Sci. U.S.A.* 93, 13508–13514.
- Meaney, M.J., Sapolsky, R.M., McEwen, B.S., 1985. The development of the glucocorticoid receptor system in the rat limbic brain. II. An autoradiographic study. *Brain Res.* 350, 165–168.
- Mehling, W., 2016. Differentiating attention styles and regulatory aspects of self-reported interoceptive sensibility. *Philos. Trans. R. Soc. Lond. B: Biol. Sci.* 371.
- Mehta, D., Siddiqui, M.F.H., Javadi, A.Y., 2018. Facial emotion recognition: a survey and real-world user experiences in mixed reality. *Sensors (Basel)* 18.
- Meng, X., Yang, J., Cai, A., Ding, X., Liu, W., Li, H., Yuan, J., 2015. The neural mechanisms underlying the aging-related enhancement of positive affects: electrophysiological evidences. *Front. Aging Neurosci.* 7, 1–15.
- Mercer, K.B., Dias, B., Shafer, D., Maddox, S.A., Mulle, J.G., Hu, P., Walton, J., Ressler, K.J., 2016. Functional evaluation of a PTSD-associated genetic variant: estradiol regulation and ADCYAP1R1. *Transl. Psychiatry* 6, e978.
- Merritt, J., Stickgold, R., Pace-Schott, E., Williams, J., Hobson, J.A., 1994. Emotion

- profiles in the dreams of men and women. *Conscious. Cogn.* 3, 46–60.
- Michopoulos, V., Rothbaum, A.O., Corwin, E., Bradley, B., Ressler, K.J., Jovanovic, T., 2014. Psychophysiology and posttraumatic stress disorder symptom profile in pregnant African-American women with trauma exposure. *Arch. Women's Mental Health* 1–10.
- Miglis, M.G., Muppidi, S., Doring, E., Jaradeh, S., 2017. A case series of REM sleep behavior disorder in pure autonomic failure. *Clin. Auton. Res.* 27, 41–44.
- Milad, M.R., Quirk, G.J., 2012. Fear extinction as a model for translational neuroscience: ten years of progress. *Annu. Rev. Psychol.* 63, 129–151.
- Miller, A.H., Raison, C.L., 2016. The role of inflammation in depression: from evolutionary imperative to modern treatment target. *Nat. Rev. Immunol.* 16, 22–34.
- Milligan, E.D., Watkins, L.R., 2009. Pathological and protective roles of glia in chronic pain. *Nat. Rev.* 10, 23–36.
- Miloyan, B., Suddendorf, T., 2015. Feelings of the future. *Trends Cogn. Sci.* 19, 196–200.
- Minami, M., Ide, S., 2015. How does pain induce negative emotion? Role of the bed nucleus of the stria terminalis in pain-induced place aversion. *Curr. Mol. Med.* 15, 184–190.
- Mollet, G.A., Harrison, D.W., 2006. Emotion and pain: a functional cerebral systems integration. *Neuropsychol. Rev.* 16, 99–121.
- Monti, M.M., Vanhaudenhuyse, A., Coleman, M.R., Boly, M., Pickard, J.D., Tshibanda, L., Owen, A.M., Laureys, S., 2010. Willful modulation of brain activity in disorders of consciousness. *N. Engl. J. Med.* 362, 579–589.
- Morgan III, C.A., Wang, S., Southwick, S.M., Rasmusson, A., Hazlett, G., Hauger, R.L., Charney, D.S., 2000. Plasma neuropeptide-Y concentrations in humans exposed to military survival training. *Biol. Psychiatry* 47, 902–909.
- Muller, M.B., Zimmermann, S., Sillaber, I., Hagemeyer, T.P., Deussing, J.M., Timpl, P., Kormann, M.S., Droste, S.K., Kuhn, R., Reul, J.M., Holsboer, F., Wurst, W., 2003. Limbic corticotropin-releasing hormone receptor 1 mediates anxiety-related behavior and hormonal adaptation to stress. *Nat. Neurosci.* 6, 1100–1107.
- Müller, V.I., Cieslik, E.C., Laird, A.R., Fox, P.T., Radua, J., Mataix-Cols, D., Tench, C.R., Yarkoni, T., Nichols, T.E., Turkeltaub, P.E., Wager, T.D., Eickhoff, S.B., 2018. Ten simple rules for neuroimaging meta-analysis. *Neurosci. Biobehav. Rev.* 84, 151–161.
- Munzner, M.D., Montero, C.S., Sutinen, E., Pajunen, J., 2014. Are they different? Affect, feeling, emotion, sentiment, and opinion detection in text. *IEEE Trans. Affect. Comput.* 5, 101–111.
- Murphy, F.C., Nimmo-Smith, I., Lawrence, A.D., 2003. Functional neuroanatomy of emotions: a meta-analysis. *Cogn. Affect. Behav. Neurosci.* 3, 207–233.
- Murphy, J., Brewer, R., Catmur, C., Bird, G., 2017. Interoception and psychopathology: a developmental neuroscience perspective. *Dev. Cogn. Neurosci.* 23, 45–56.
- Murray, G., Allen, N.B., Trinder, J., 2002. Mood and the circadian system: investigation of a circadian component in positive affect. *Chronobiol. Int.* 19, 1151–1169.
- Murray, G., Nicholas, C.L., Kleiman, J., Dwyer, R., Carrington, M.J., Allen, N.B., Trinder, J., 2009. Nature's clocks and human mood: the circadian system modulates reward motivation. *Emotion (Washington, DC)* 9, 705–716.
- Mysliwiec, V., Brock, M.S., Creamer, J.L., O'Reilly, B.M., Germain, A., Roth, B.J., 2018. Trauma associated sleep disorder: a parasomnia induced by trauma. *Sleep Med. Rev.* 37, 94–104.
- Nakatomi, Y., Mizuno, K., Ishii, A., Wada, Y., Tanaka, M., Tazawa, S., Onoe, K., Fukuda, S., Kawabe, J., Takahashi, K., Kataoka, Y., Shiomi, S., Yamaguti, K., Inaba, M., Kuratsune, H., Watanabe, Y., 2014. Neuroinflammation in patients with chronic fatigue syndrome/myalgic encephalomyelitis: An (1)(1)C-(R)-PK11195 PET study. *J. Nucl. Med.* 55, 945–950.
- Namkung, H., Kim, S.H., Sawa, A., 2017. The insula: an underestimated brain area in clinical neuroscience, psychiatry, and neurology. *Trends Neurosci.* 40, 200–207.
- Nentjes, L., Meijer, E., Bernstein, D., Arntz, A., Medendorp, W., 2013. Brief communication: investigating the relationship between psychopathy and interoceptive awareness. *J. Pers. Disord.* 27, 617–624.
- Nesse, R.M., 1990. Evolutionary explanations of emotions. *Hum. Nat.* 1, 261–289.
- Nielsen, T., Carr, M., 2017. Nightmares and nightmare function. In: Kryger, M.H., Roth, T., Dement, W.C. (Eds.), *Principles and Practice of Sleep Medicine*, 6th ed. Elsevier, Philadelphia, pp. 546–554.
- Nielsen, T., Levin, R., 2007. Nightmares: a new neurocognitive model. *Sleep Med. Rev.* 11, 295–310.
- Nielsen, T.A., 2000. A review of mentation in REM and NREM sleep: “covert” REM sleep as a possible reconciliation of two opposing models. *Behav. Brain Sci.* 23, 851–866 discussion 904–1121.
- Nielsen, T.A., Deslauriers, D., Baylor, G.W., 1991. Emotions in dream and waking event reports. *Dreaming* 1, 287–300.
- Nielsen, T.A., McGregor, D.L., Zadra, A., Ilnicki, D., Ouellet, L., 1993. Pain in dreams. *Sleep* 16, 490–498.
- Nilini, Y.I., Pineles, S.L., Patton, S.C., Rouse, M.H., Sawyer, A.T., Rasmusson, A.M., 2015. Menstrual cycle effects on psychological symptoms in women with PTSD. *J. Trauma Stress* 28, 1–7.
- Nilini, Y.I., Toufexis, D.J., Rohan, K.J., 2011. Anxiety sensitivity, the menstrual cycle, and panic disorder: a putative neuroendocrine and psychological interaction. *Clin. Psychol. Rev.* 31, 1183–1191.
- Nofzinger, E.A., Buysse, D.J., Germain, A., Carter, C., Luna, B., Price, J.C., Meltzer, C.C., Miewald, J.M., Reynolds 3rd, C.F., Kupfer, D.J., 2004. Increased activation of anterior paralimbic and executive cortex from waking to rapid eye movement sleep in depression. *Arch. Gen. Psychiatry* 61, 695–702.
- Nofzinger, E.A., Mintun, M.A., Wiseman, M., Kupfer, D.J., Moore, R.Y., 1997. Forebrain activation in REM sleep: an FDG PET study. *Brain Res.* 770, 192–201.
- Northoff, G., Schneider, F., Rotte, M., Matthiae, C., Tempelmann, C., Wiebking, C., Bermühl, F., Heinz, A., Danos, P., Heinze, H.J., Bogerts, B., Walter, M., Panksepp, J., 2009. Differential parametric modulation of self-relatedness and emotions in different brain regions. *Hum. Brain Mapp.* 30, 369–382.
- Nugent, A.C., Bain, E.E., Thayer, J.F., Sollers 3rd, J.J., Drevets, W.C., 2011. Heart rate variability during motor and cognitive tasks in females with major depressive disorder. *Psychiatry Res.* 191, 1–8.
- Nummenmaa, L., Glerean, E., Hari, R., Hietanen, J.K., 2014. Bodily maps of emotions. *Proc. Natl. Acad. Sci. U.S.A.* 111, 646–651.
- Nyklíček, I., Thayer, J.F., Van Doornen, L.J., 1997. Cardiorespiratory differentiation of musically-induced emotions. *J. Psychophysiol.* 11, 780–790.
- O'Kelly, J., James, L., Palaniappan, R., Taborin, J., Fachner, J., Magee, W.L., 2013. Neurophysiological and behavioral responses to music therapy in vegetative and minimally conscious states. *Front. Hum. Neurosci.* 7, 884.
- Ohman, A., 1986. Face the beast and fear the face: animal and social fears as prototypes for evolutionary analyses of emotion. *Psychophysiology* 23, 123–145.
- Ohman, A., Mineka, S., 2001. Fears, phobias, and preparedness: toward an evolved module of fear and fear learning. *Psychol. Rev.* 108, 483–522.
- Olofsson, J.K., Nordin, S., Sequeira, H., Polich, J., 2008. Affective picture processing: an integrative review of ERP findings. *Biol. Psychol.* 77, 247–265.
- Orr, S.P., Lasko, N.B., Metzger, L.J., Berry, N.J., Ahern, C.E., Pitman, R.K., 1997. Psychophysiological assessment of PTSD in adult females sexually abused during childhood. *Ann. N.Y. Acad. Sci.* 821, 491–493.
- Orr, S.P., Metzger, L.J., Pitman, R.K., 2002. Psychophysiology of post-traumatic stress disorder. *Psychiatr. Clin. North Am.* 25, 271–293.
- Otten, M., Seth, A.K., Pinto, Y., 2017. A social Bayesian brain: how social knowledge can shape visual perception. *Brain Cogn.* 112, 69–77.
- Oudiette, D., De Cock, V.C., Lavault, S., Leu, S., Vidalheth, M., Arnulf, I., 2009. Nonviolent elaborate behaviors may also occur in REM sleep behavior disorder. *Neurology* 72, 551–557.
- Pace-Schott, E.F., 2015. Foreword: Interrelationships between sleep and affect. In: Babson, K.A., Feldner, M.T. (Eds.), *Sleep and Affect: Assessment, Theory, and Clinical Implications*. Academic Press, London, UK, pp. xiii–xxvi.
- Pace-Schott, E.F., Germain, A., Milad, M.R., 2015a. Effects of sleep on memory for conditioned fear and fear extinction. *Psychol. Bull.* 141, 835–857.
- Pace-Schott, E.F., Germain, A., Milad, M.R., 2015b. Sleep and REM sleep disturbance in the pathophysiology of PTSD: the role of extinction memory. *Biol. Mood Anxiety Disord.* 5, 3.
- Pace-Schott, E.F., Subson, J.A., 2002. The neurobiology of sleep: genetics, cellular physiology and subcortical networks. *Nat. Rev.* 3, 591–605.
- Pace-Schott, E.F., Picchioni, D., 2017. The neurobiology of dreaming. In: Kryger, M.H., Roth, T., Dement, W.C. (Eds.), *Principles and Practice of Sleep Medicine*, 6th ed. pp. 529–538 Philadelphia, PA.
- Pace-Schott, E.F., Spencer, R.M., Vijayakumar, S., Ahmed, N.A., Verga, P.W., Orr, S.P., Pitman, R.K., Milad, M.R., 2013. Extinction of conditioned fear is better learned and recalled in the morning than in the evening. *J. Psychiatr. Res.* 47, 1776–1784.
- Palmer, C.A., Alfano, C.A., 2016. Sleep and emotion regulation: an organizing, integrative review. *Sleep Med. Rev.*
- Palmer, C.A., Alfano, C.A., 2017. Sleep and emotion regulation: an organizing, integrative review. *Sleep Med. Rev.* 31, 6–16.
- Palumbo, R.V., Marraccini, M.E., Weyandt, L.L., Wilder-Smith, O., McGee, H.A., Liu, S., Goodwin, M.S., 2017. Interpersonal autonomic physiology: a systematic review of the literature. *Pers. Soc. Psychol. Rev.* 21, 99–141.
- Panksepp, J., 2000. The neuro-evolutionary cusp between emotions and cognitions: implications for understanding consciousness and the emergence of a unified mind science. *Conscious. Emotion* 1, 15–54.
- Panksepp, J., 2010. Affective neuroscience of the emotional BrainMind: evolutionary perspectives and implications for understanding depression. *Dialog. Clin. Neurosci.* 12, 533–545.
- Papez, J.W., 1937. A proposed mechanism of emotion. *Arch. Neurol. Psychiatry* 38, 725–734.
- Park, E., Gallezot, J.D., Delgado, A., Liu, S., Planeta, B., Lin, S.F., O'Connor, K.C., Lim, K., Lee, J.Y., Chastre, A., Chen, M.K., Seneca, N., Leppert, D., Huang, Y., Carson, R.E., Pelletier, D., 2015. (1)(1)C-PBR28 imaging in multiple sclerosis patients and healthy controls: test–retest reproducibility and focal visualization of active white matter areas. *Eur. J. Nucl. Med. Mol. Imaging* 42, 1081–1092.
- Park, H.D., Correia, S., Ducorps, A., Tallon-Baudry, C., 2014. Spontaneous fluctuations in neural responses to heartbeats predict visual detection. *Nat. Neurosci.* 17, 612–618.
- Parmeggiani, P.L., 1985. Regulation of circulation and breathing during sleep: experimental aspects. *Ann. Clin. Res.* 17, 185–189.
- Paulus, M.P., Stein, M.B., 2010. Interoception in anxiety and depression. *Brain Struct. Funct.* 214, 451–463.
- Paulus, M.P., Stewart, J.L., 2014. Interoception and drug addiction. *Neuropharmacology* 76 (Pt B), 342–350.
- Paulus, M.P., Tapert, S.F., Schulteis, G., 2009. The role of interoception and alliesthesia in addiction. *Pharmacol. Biochem. Behav.* 94, 1–7.
- Paulus, M.P., Yu, A.J., 2012. Emotion and decision-making: affect-driven belief systems in anxiety and depression. *Trends Cogn. Sci.* 16, 476–483.
- Pecchinenda, A., Smith, C.A., 1996. The affective significance of skin conductance activity during a difficult problem-solving task. *Cogn. Emotion* 10, 481–503.
- Perlis, M.L., Nielsen, T.A., 1993. Mood regulation, dreaming and nightmares: evaluation of a desensitization function for REM sleep. *Dreaming* 3, 243–257.
- Perogamvros, L., Dang-Vu, T.T., Desseilles, M., Schwartz, S., 2013. Sleep and dreaming are for important matters. *Front. Psychol.* 4, 474.
- Pessoa, L., Adolphs, R., 2010. Emotion processing and the amygdala: from a ‘low road’ to ‘many roads’ of evaluating biological significance. *Nat. Rev. Neurosci.* 11, 773–783.
- Peterson, R.A., Reiss, S., 1987. *Anxiety Sensitivity Index Manual*. International Diagnostic Systems, Worthington, OH.
- Pfabis, D.M., Seidel, E.M., Sladky, R., Hahn, A., Paul, K., Grahl, A., Kublbock, M., Kraus, C., Hummer, A., Kranz, G.S., Windischberger, C., Lanzenberger, R., Lamm, C., 2014. P300 amplitude variation is related to ventral striatum BOLD response during gain and loss anticipation: an EEG and fMRI experiment. *Neuroimage* 96, 12–21.
- Pfaus, J.G., Damsa, G., Wenkstern, D., Fibiger, H.C., 1995. Sexual activity increases dopamine transmission in the nucleus accumbens and striatum of female rats. *Brain Res.* 693, 21–30.
- Pfeifer, J.H., Masten, C.L., Moore, W.E., Oswald, T.M., Mazziotta, J.C., Iacoboni, M., Dapretto, M., 2011. Entering adolescence: resistance to peer influence, risky behavior, and neural changes in emotion reactivity. *Neuron* 69, 1029–1036.



- Phan, K.L., Wager, T., Taylor, S.F., Liberzon, I., 2002. Functional neuroanatomy of emotion: a meta-analysis of emotion activation studies in PET and fMRI. *Neuroimage* 16, 331–348.
- Phan, K.L., Wager, T.D., Taylor, S.F., Liberzon, I., 2004. Functional neuroimaging studies of human emotions. *CNS Spectr.* 9, 258–266.
- Phillips, M.L., Ladouceur, C.D., Drevets, W.C., 2008. A neural model of voluntary and automatic emotion regulation: implications for understanding the pathophysiology and neurodevelopment of bipolar disorder. *Mol. Psychiatry* 13, 833–857.
- Pineles, S.L., Suvak, M.K., Liverant, G.I., Gregor, K., Wisco, B.E., Pitman, R.K., Orr, S.P., 2013. Psychophysiological reactivity, subjective distress, and their associations with PTSD diagnosis. *J. Abnorm. Psychol.* 122, 635–644.
- Pinker, S., 2018. *Enlightenment Now: The Case for Reason, Science, Humanism, and Progress*. Viking, New York.
- Pitman, R.K., Orr, S.P., Forgue, D.F., de Jong, J.B., Claiborn, J.M., 1987. Psychophysiological assessment of posttraumatic stress disorder imagery in Vietnam combat veterans. *Arch. Gen. Psychiatry* 44, 970–975.
- Pitskel, N.B., Bolling, D.Z., Kaiser, M.D., Crowley, M.J., Pelphrey, K.A., 2011. How grossed out are you? The neural basis of emotion regulation from childhood to adolescence. *Dev. Cogn. Neurosci.* 1, 324–337.
- Plutchik, R., 1980. A general psychoevolutionary theory of emotion. In: Plutchik, R., Kellerman, H. (Eds.), *Emotion: Theory, Research, and Experience*. Academic Press, New York, NY, USA, pp. 3–33.
- Pole, N., 2007. The psychophysiology of posttraumatic stress disorder: a meta-analysis. *Psychol. Bull.* 133, 725–746.
- Pole, N., Neylan, T.C., Best, S.R., Orr, S.P., Marmar, C.R., 2003. Fear-potentiated startle and posttraumatic stress symptoms in urban police officers. *J. Trauma Stress* 16, 471–479.
- Pole, N., Neylan, T.C., Otte, C., Henn-Hasse, C., Metzler, T.J., Marmar, C.R., 2009. Prospective prediction of posttraumatic stress disorder symptoms using fear-potentiated auditory startle responses. *Biol. Psychiatry* 65, 235–240.
- Pollak, S.D., Kistler, D.J., 2002. Early experience is associated with the development of categorical representations for facial expressions of emotion. *Proc. Natl. Acad. Sci. U.S.A.* 99, 9072–9076.
- Pollatos, O., Herbert, B.M., Matthias, E., Schandry, R., 2007. Heart rate response after emotional picture presentation is modulated by interoceptive awareness. *Int. J. Psychophysiol.* 63, 117–124.
- Pollatos, O., Schandry, R., 2004. Accuracy of heartbeat perception is reflected in the amplitude of the heartbeat-evoked brain potential. *Psychophysiology* 41, 476–482.
- Porges, S.W., 2009. The polyvagal theory: new insights into adaptive reactions of the autonomic nervous system. *Cleve. Clin. J. Med.* 76 (Suppl 2), S86–S90.
- Porges, S.W., 2011. *The Polyvagal Theory. Neurophysiological Foundations of Emotions, Attachment, Communication, and Self-regulation*. Norton, New York.
- Porges, S.W., Carter, S., 2011. Polyvagal Theory, Oxytocin and the Neurobiology of Love and Attachment: Using the Body's Social Engagement System to Promote Recovery from Experiences of Threat, Stress and Trauma. Sydney.
- Porkka-Heiskanen, T., Kalinchuk, A.V., 2011. Adenosine, energy metabolism and sleep homeostasis. *Sleep Med. Rev.* 15, 123–135.
- Porte, H.S., Hobson, J.A., 1996. Physical motion in dreams: one measure of three theories. *J. Abnorm. Psychol.* 105, 329–335.
- Posner, J., Russell, J.A., Peterson, B.S., 2005. The circumplex model of affect: an integrative approach to affective neuroscience, cognitive development, and psychopathology. *Dev. Psychopathol.* 17, 715–734.
- Pourtois, G., Delplanque, S., Michel, C., Vuilleumier, P., 2008. Beyond conventional event-related brain potential (ERP): exploring the time-course of visual emotion processing using topographic and principal component analyses. *Brain Topogr.* 20, 265–277.
- Preuschoft, S., 1992. “Laughter” and “smile” in Barbary macaques (*Macaca sylvanus*). *Ethology* 91, 220–236.
- Quattrocki, E., Friston, K., 2014. Autism, oxytocin and interoception. *Neurosci. Biobehav. Rev.* 47, 410–430.
- Quigley, K.S., Barrett, L.F., 2014. Is there consistency and specificity of autonomic changes during emotional episodes? Guidance from the Conceptual Act Theory and psychophysiology. *Biol. Psychol.* 98, 82–94.
- Quirk, G.J., Mueller, D., 2008. Neural mechanisms of extinction learning and retrieval. *Neuropsychopharmacology* 33, 56–72.
- Raimondo, F., Rohaut, B., Demertzi, A., Valente, M., Engemann, D.A., Salti, M., Fernandez Slezak, D., Naccache, L., Sitt, J.D., 2017. Brain–heart interactions reveal consciousness in noncommunicating patients. *Ann. Neurol.* 82, 578–591.
- Rao, S.M., Huber, S.J., Bornstein, R.A., 1992. Emotional changes with multiple sclerosis and Parkinson's disease. *J. Consult. Clin. Psychol.* 60, 369–378.
- Rasch, B., Born, J., 2013. About sleep's role in memory. *Physiol. Rev.* 93, 681–766.
- Raymond, C., Marin, M.F., Majeur, D., Lupien, S., 2017. Early child adversity and psychopathology in adulthood: HPA axis and cognitive dysregulations as potential mechanisms. *Prog. Neuropsychopharmacol. Biol. Psychiatry*.
- Raymond, I., Nielsen, T.A., Lavigne, G., Choiniere, M., 2002. Incorporation of pain in dreams of hospitalized burn victims. *Sleep* 25, 765–770.
- Rebollo, I., Devauchelle, A.D., Beranger, B., Tallon-Baudry, C., 2018. Stomach-brain synchrony reveals a novel, delayed-connectivity resting-state network in humans. *eLife* 7.
- Reichenberg, A., Yirmiya, R., Schuld, A., Kraus, T., Haack, M., Morag, A., Pollmacher, T., 2001. Cytokine-associated emotional and cognitive disturbances in humans. *Arch. Gen. Psychiatry* 58, 445–452.
- Ressler, K.J., Mercer, K.B., Bradley, B., Jovanovic, T., Mahan, A., Kerley, K., Norrholm, S.D., Kilalu, V., Smith, A.K., Myers, A.J., Ramirez, M., Engel, A., Hammack, S.E., Toufexis, D., Braas, K.M., Binder, E.B., May, V., 2011. Post-traumatic stress disorder is associated with PACAP and the PAC1 receptor. *Nature* 470, 492–497.
- Reul, J.M., de Kloet, E.R., 1985. Two receptor systems for corticosterone in rat brain: microdistribution and differential occupation. *Endocrinology* 117, 2505–2511.
- Reuter, J., Raedler, T., Rose, M., Hand, I., Glascher, J., Buchel, C., 2005. Pathological gambling is linked to reduced activation of the mesolimbic reward system. *Nat. Neurosci.* 8, 147–148.
- Revonsuo, A., 2000. The reinterpretation of dreams: an evolutionary hypothesis of the function of dreaming. *Behav. Brain Sci.* 23, 877–901 discussion 904–1121.
- Richards, J.M., Gross, J.J., 2000. Emotion regulation and memory: the cognitive costs of keeping one's cool. *J. Pers. Soc. Psychol.* 79, 410–424.
- Riganello, F., Chatelle, C., Schnakers, C., Laureys, S., 2019. Heart rate variability as an indicator of nociceptive pain in disorders of consciousness? *J. Pain Symptom Manage.* 57, 47–56.
- Riganello, F., Larroque, S.K., Bahri, M.A., Heine, L., Martial, C., Carriere, M., Charland-Verville, V., Aubinet, C., Vanhauzenhuyse, A., Chatelle, C., Laureys, S., Di Perri, C., 2018. A heartbeat away from consciousness: heart rate variability entropy can discriminate disorders of consciousness and is correlated with resting-state fMRI brain connectivity of the central autonomic network. *Frontiers in neurology* 9, 769.
- Rilling, J.K., Young, L.J., 2014. The biology of mammalian parenting and its effect on offspring social development. *Science (New York, NY)* 345, 771–776.
- Rinaman, L., 2007. Visceral sensory inputs to the endocrine hypothalamus. *Front. Neuroendocrinol.* 28, 50–60.
- Risbrough, V.B., Stein, M.B., 2006. Role of corticotropin releasing factor in anxiety disorders: a translational research perspective. *Horm. Behav.* 50, 550–561.
- Ritchie, T., Skowronski, J.J., Hartnett, J., Wells, B., Walker, W.R., 2009. The fading affect bias in the context of emotion activation level, mood, and personal theories of emotion change. *Memory* 17, 428–444.
- Robinson, J.L., Laird, A.R., Glahn, D.C., Lovallo, W.R., Fox, P.T., 2010. Metaanalytic connectivity modeling: delineating the functional connectivity of the human amygdala. *Hum. Brain Mapp.* 31, 173–184.
- Robinson, S., Sandstrom, S.M., Denenberg, V.H., Palmiter, R.D., 2005. Distinguishing whether dopamine regulates liking, wanting, and/or learning about rewards. *Behav. Neurosci.* 119, 5–15.
- Rook, G.A., Raison, C.L., Lowry, C.A., 2014. Microbiota, immunoregulatory old friends and psychiatric disorders. *Adv. Exp. Med. Biol.* 817, 319–356.
- Roosendaal, B., Barsegyan, A., Lee, S., 2008. Adrenal stress hormones, amygdala activation, and memory for emotionally arousing experiences. *Prog. Brain Res.* 167, 79–97.
- Rotenberg, V.S., 2006. REM sleep function and brain monoamine regulation. In: Lader, M.H., Cardinali, D.P., Pandi-Perumal, S.R. (Eds.), *Sleep and Sleep Disorders*. Springer, Boston, MA, pp. 27–35.
- Rotenberg, J., Clift, A., Bolden, S., Salomon, K., 2007. RSA fluctuation in major depressive disorder. *Psychophysiology* 44, 450–458.
- Roy, M., Shohamy, D., Wager, T.D., 2012. Ventromedial prefrontal-subcortical systems and the generation of affective meaning. *Trends Cogn. Sci.* 16, 147–156.
- Rozin, P., Fallon, A.E., 1987. A perspective on disgust. *Psychol. Rev.* 94, 23–41.
- Ruffault, A., Czernichow, S., Hagger, M.S., Ferrand, M., Erichot, N., Carette, C., Boujut, E., Flahault, C., 2017. The effects of mindfulness training on weight-loss and health-related behaviours in adults with overweight and obesity: a systematic review and meta-analysis. *Obes. Res. Clin. Pract.* 11, 90–111.
- Rugg, M.D., Coles, M.G., 1995. *The ERP and Cognitive Psychology: Conceptual Issues*. Russell, J.A., 2003. Core affect and the psychological construction of emotion. *Psychol. Rev.* 110, 145–172.
- Sabatini, D., Lang, P.J., Keil, A., Bradley, M.M., 2007. Emotional perception: correlation of functional MRI and event-related potentials. *Cereb. Cortex* 17, 1085–1091.
- Salamone, J.D., 1992. Complex motor and sensorimotor functions of striatal and accumbens dopamine: involvement in instrumental behavior processes. *Psychopharmacology (Berl)* 107, 160–174.
- Salmirago-Blotcher, E., Carey, M.P., 2018. Can mindfulness training improve medication adherence? Integrative review of the current evidence and proposed conceptual model. *Explore (NY)* 14, 59–65.
- Salomon, K., Bylsma, L.M., White, K.E., Panaite, V., Rottenberg, J., 2013. Is blunted cardiovascular reactivity in depression mood-state dependent? A comparison of major depressive disorder remitted depression and healthy controls. *Int. J. Psychophysiol.* 90, 50–57.
- Salomon, K., Clift, A., Karlsdottir, M., Rottenberg, J., 2009. Major depressive disorder is associated with attenuated cardiovascular reactivity and impaired recovery among those free of cardiovascular disease. *Health Psychol.* 28, 157–165.
- Sanchez, M.M., Young, L.J., Plotsky, P.M., Insel, T.R., 2000. Distribution of corticosteroid receptors in the rhesus brain: relative absence of glucocorticoid receptors in the hippocampal formation. *J. Neurosci.* 20, 4657–4668.
- Sandiego, C.M., Gallezot, J.D., Pittman, B., Nabulsi, N., Lim, K., Lin, S.F., Matuskey, D., Lee, J.Y., O'Connor, K.C., Huang, Y., Carson, R.E., Hannestad, J., Cosgrove, K.P., 2015. Imaging robust microglial activation after lipopolysaccharide administration in humans with PET. *Proc. Natl. Acad. Sci. U.S.A.* 112, 12468–12473.
- Santoro, N., Epperson, C.N., Mathews, S.B., 2015. Menopausal symptoms and their management. *Endocrinol. Metab. Clin. North Am.* 44, 497–515.
- Sarrieu, A., Dussaillant, M., Sapolsky, R.M., Aitken, D.H., Olivier, A., Lal, S., Rostene, W.H., Quirion, R., Meaney, M.J., 1988. Glucocorticoid binding sites in human temporal cortex. *Brain Res.* 442, 157–160.
- Sassin, J.F., Parker, D.C., Mace, J.W., Gotlin, R.W., Johnson, L.C., Rossman, L.G., 1969. Human growth hormone release: relation to slow-wave sleep and sleep-walking cycles. *Science* 165, 513–515.
- Saxe, R., Houlihan, S.D., 2017. Formalizing emotion concepts within a Bayesian model of theory of mind. *Curr. Opin. Psychol.* 17, 15–21.
- Sbarra, D.A., Hazan, C., 2008. Coregulation, dysregulation, self-regulation: an integrative analysis and empirical agenda for understanding adult attachment, separation, loss, and recovery. *Pers. Soc. Psychol. Rev.* 12, 141–167.
- Schachter, S., Singer, J.E., 1962. Cognitive, social, and physiological determinants of emotional state. *Psychol. Rev.* 69, 379–399.
- Scherer, K.R., 1984. Emotion as a multicomponent process: a model and some cross-cultural data. In: Shaver, P. (Ed.), *Review of Personality and Social Psychology*. Sage, Beverly Hills, CA, pp. 37–63.
- Schienze, A., Stark, R., Walter, B., Blecker, C., Ott, U., Kirsch, P., Sammer, G., Vaitl, D., 2002. The insula is not specifically involved in disgust processing: an fMRI study.



- Neuroreport 13, 2023–2026.
- Schlereth, T., Birklein, F., 2008. The sympathetic nervous system and pain. *Neuromol. Med.* 10, 141–147.
- Schmeichel, B.J., Demaree, H.A., 2010. Working memory capacity and spontaneous emotion regulation: high capacity facilitates self-enhancement in response to negative feedback. *Emotion (Washington, DC)* 10, 739–744.
- Schmidt, L.A., Schulkin, J., 2000. Toward a computational affective neuroscience. *Brain Cogn.* 42, 95–98.
- Schnakers, C., Perrin, F., Schabus, M., Majerus, S., Ledoux, D., Damas, P., Boly, M., Vanhaudenhuyse, A., Bruno, M.A., Moonen, G., Laureys, S., 2008. Voluntary brain processing in disorders of consciousness. *Neurology* 71, 1614–1620.
- Schnall, S., Haidt, J., Clore, G.L., Jordan, A.H., 2008. Disgust as embodied moral judgment. *Pers. Soc. Psychol. Bull.* 34, 1096–1109.
- Schore, A.N., 2003. *Affect Regulation and the Repair of the Self*. WW Norton & Co., New York.
- Schredl, M., Doll, E., 1998. Emotions in diary dreams. *Conscious. Cogn.* 7, 634–646.
- Schultz, W., 2015. Neuronal reward and decision signals: from theories to data. *Physiol. Rev.* 95, 853–951.
- Schulz, A., Matthey, J.H., Voge, C., Schaan, V., Schachinger, H., Adler, J., Beutel, M.E., Michal, M., 2016. Cardiac modulation of startle is altered in depersonalization-/de-realization disorder: evidence for impaired brainstem representation of baro-afferent neural traffic. *Psychiatry Res.* 240, 4–10.
- Schulz, A., Strelzyk, F., Ferreira de Sa, D.S., Naumann, E., Voge, C., Schachinger, H., 2013. Cortisol rapidly affects amplitudes of heartbeat-evoked brain potentials – implications for the contribution of stress to an altered perception of physical sensations? *Psychoneuroendocrinology* 38, 2686–2693.
- Schulz, A., Voge, C., 2015. Interoception and stress. *Front. Psychol.* 6, 993.
- Schulz, S.M., 2016. Neural correlates of heart-focused interoception: a functional magnetic resonance imaging meta-analysis. *Philos. Trans. R. Soc. Lond. B: Biol. Sci.* 371.
- Schupp, H.T., Junghofer, M., Weike, A.I., Hamm, A.O., 2004. The selective processing of briefly presented affective pictures: an ERP analysis. *Psychophysiology* 41, 441–449.
- Schwartz, G.E., Davidson, R.J., Maer, F., 1975. Right hemisphere lateralization for emotion in the human brain: interactions with cognition. *Science* 190, 286–288.
- Segal, Z.V., Williams, J.M.G., Teasdale, J.D., 2002. *Mindfulness-based Cognitive Therapy for Depression: A New Approach to Preventing Relapse*. Guilford Press, New York.
- Selvaraj, S., Bloomfield, P.S., Cao, B., Veronesi, M., Turkheimer, F., Howes, O.D., 2018. Brain TSPo imaging and gray matter volume in schizophrenia patients and in people at ultra high risk of psychosis: an ([11C]PBR28 study. *Schizophr. Res.* 195, 206–214.
- Seo, J., Moore, K.N., Gazecki, S., Bottary, R.M., Milad, M.R., Song, H., Pace-Schott, E.F., 2018. Delayed fear extinction in individuals with insomnia disorder. *Sleep* 41.
- Sereno, S.C., Scott, G.G., Yao, B., Thaden, E.J., O'Donnell, P.J., 2015. Emotion word processing: does mood make a difference? *Front. Psychol.* 6, 1191.
- Servick, K., 2016. Primed for pain. *Science* 354, 569–571.
- Seth, A.K., 2013. Interoceptive inference, emotion, and the embodied self. *Trends Cogn. Sci.* 17, 565–573.
- Seth, A.K., Friston, K.J., 2016. Active interoceptive inference and the emotional brain. *Philos. Trans. R. Soc. Lond. B: Biol. Sci.* 371.
- Shalev, A.Y., Orr, S.P., Pitman, R.K., 1993. Psychophysiological assessment of traumatic imagery in Israeli civilian patients with posttraumatic stress disorder. *Am. J. Psychiatry* 150, 620–624.
- Shamay-Tsoory, S.G., Abu-Akel, A., 2016. The social salience hypothesis of oxytocin. *Biol. Psychiatry* 79, 194–202.
- Simon, H.A., 1967. Motivational and emotional controls of cognition. *Psychol. Rev.* 74, 29–39.
- Singer, T., Critchley, H.D., Preusschoff, K., 2009. A common role of insula in feelings, empathy and uncertainty. *Trends Cogn. Sci.* 13, 334–340.
- Skeldon, A.C., Derks, G., Dijk, D.J., 2016. Modelling changes in sleep timing and duration across the lifespan: changes in circadian rhythmicity or sleep homeostasis? *Sleep Med. Rev.* 28, 96–107.
- Smith, M.T., Edwards, R.R., McCann, U.D., Haythornthwaite, J.A., 2007. The effects of sleep deprivation on pain inhibition and spontaneous pain in women. *Sleep* 30, 494–505.
- Smith, R., Gardiner, J., Luo, Z., Schooley, S., Lamerato, L., 2009. Primary care physicians treat somatization. *J. Gen. Intern. Med.* 24, 829–832.
- Smith, R., Laird-Fick, H., D'Mello, D., Dwamena, F., Romain, A., Olson, J., Kent, K., Blackman, K., Solomon, D., Spoolstra, M., Fortin VI, A.H., Frey, J., Ferenchick, G., Freilich, L., Meerschaeft, C., Frankel, R., 2014. Addressing mental health issues in primary care: an initial curriculum for medical residents. *Patient Educ. Couns.* 94, 33–42.
- Smith, R.C., Dwamena, F.C., 2007. Classification and diagnosis of patients with medically unexplained symptoms. *J. Gen. Intern. Med.* 22, 685–691.
- Smith, R.C., Lein, C., Collins, C., Lyles, J.S., Given, B., Dwamena, F.C., Coffey, J., Hodges, A., Gardiner, J.C., Goddeeris, J., Given, C.W., 2003. Treating patients with medically unexplained symptoms in primary care. *J. Gen. Intern. Med.* 18, 478–489 PMID: PMC1494880.
- Smith, R.C., Lyles, J.S., Gardiner, J.C., Sirbu, C., Hodges, A., Collins, C., Dwamena, F.C., Lein, C., Given, C.W., Given, B., Goddeeris, J., 2006. Primary care clinicians treat patients with medically unexplained symptoms – a randomized controlled trial. *J. Gen. Intern. Med.* 21, 671–677 PMID: PMC1924714.
- Smith, R.C., Lyles, J.S., Mettler, J., Stoffelmayr, B.E., Van Egeren, L.F., Marshall, A.M., Gardiner, J.C., Maduschke, K.M., Stanley, J.M., Osborn, G.G., Shebroe, V., Greenbaum, R.B., 1998. The effectiveness of intensive training for residents in interviewing. A randomized, controlled study. *Ann. Intern. Med.* 128, 118–126.
- Somerville, L.H., Whalen, P.J., Kelley, W.M., 2010. Human bed nucleus of the stria terminalis indexes hypervigilant threat monitoring. *Biol. Psychiatry* 68, 416–424.
- Steinboff, N., Heine, A.M., Vogl, J., Weiss, K., Aschraf, A., Hajek, P., Schneider, P., Tucek, G., 2015. A pilot study into the effects of music therapy on different areas of the brain of individuals with unresponsive wakefulness syndrome. *Front. Neurosci.* 9, 291.
- Stemmler, G., 1992. *Differential Psychophysiology: Persons in Situations*. Springer, New York City, NY.
- Stemmler, G., 2003. Methodological considerations in the psychophysiological study of emotion. In: Davidson, R.J., Scherer, K.R., Goldsmith, H. (Eds.), *Handbook of Affective Sciences*. Oxford University Press, New York, pp. 225–255.
- Stephens, C.L., Christie, I.C., Friedman, B.H., 2010. Autonomic specificity of basic emotions: evidence from pattern classification and cluster analysis. *Biol. Psychol.* 84, 463–473.
- Strahler, J., Skoluda, N., Kappert, M.B., Nater, U.M., 2017. Simultaneous measurement of salivary cortisol and alpha-amylase: application and recommendations. *Neurosci. Biobehav. Rev.* 83, 657–677.
- Strigo, I.A., Craig, A.D., 2016. Interoception, homeostatic emotions and sympathovagal balance. *Philos. Trans. R. Soc. Lond. B: Biol. Sci.* 371.
- Sun, J., Chen, W., 2015. Music therapy for coma patients: preliminary results. *Eur. Rev. Med. Pharmacol. Sci.* 19, 1209–1218.
- Sunagawa, K., Kawada, T., Nakahara, T., 1998. Dynamic nonlinear vago-sympathetic interaction in regulating heart rate. *Heart Vessels* 13, 157–174.
- Tabor, A., Thacker, M.A., Moseley, G.L., Kording, K.P., 2017. Pain: a statistical account. *PLoS Comput. Biol.* 13, e1005142.
- Tempesta, D., Succi, V., De Gennaro, L., Ferrara, M., 2017. Sleep and emotional processing. *Sleep Med. Rev.*
- Terasawa, Y., Moriguchi, Y., Tochizawa, S., Umeda, S., 2014. Interoceptive sensitivity predicts sensitivity to the emotions of others. *Cogn. Emotion* 28, 1435–1448.
- Thayer, J.F., Ahs, F., Fredrikson, M., Sollers 3rd, J.J., Wager, T.D., 2012. A meta-analysis of heart rate variability and neuroimaging studies: implications for heart rate variability as a marker of stress and health. *Neurosci. Biobehav. Rev.* 36, 747–756.
- Thayer, J.F., Friedman, B.H., 1997. *The Heart of Anxiety: A Dynamical Systems Approach*. In: Vingerhoets, A.J. (Ed.), *The (Non)Expression of Emotions in Health and Disease*. Springer Verlag, Amsterdam.
- Thayer, J.F., Lane, R.D., 2000. A model of neurovisceral integration in emotion regulation and dysregulation. *J. Affect. Disord.* 61, 201–216.
- Thayer, J.F., Lane, R.D., 2009. Claude Bernard and the heart–brain connection: further elaboration of a model of neurovisceral integration. *Neurosci. Biobehav. Rev.* 33, 81–88.
- Thiruchselvam, R., Hajcak, G., Gross, J.J., 2012. Looking inward: shifting attention within working memory representations alters emotion responses. *Psychol. Sci.* 23, 1461–1466.
- Thompson, R., 1991. Emotional regulation and emotional development. *Educ. Psychol. Rev.* 3, 269–307.
- Thompson, R.F., Spencer, W.A., 1966. Habituation: a model phenomenon for the study of neuronal substrates of behavior. *Psychol. Rev.* 73, 16–43.
- Thonnard, M., Wannez, S., Keen, S., Bredart, S., Bruno, M.A., Gosseries, O., Demertzi, A., Thibaut, A., Chatelle, C., Charland-Verville, V., Heine, L., Habbal, D., Laureys, S., Vanhaudenhuyse, A., 2014. Detection of visual pursuit in patients in minimally conscious state: a matter of stimuli and visual plane? *Brain Inj.* 28, 1164–1170.
- Tissari, H., 2016. Current emotion research in English linguistics: words for emotions in the history of English. *Emotion Rev.* 1.
- Tobaldini, E., Toschi-Dias, E., Trimarchi, P.D., Brena, N., Comanducci, A., Casarotto, S., Montano, N., Devalle, G., 2018. Cardiac autonomic responses to nociceptive stimuli in patients with chronic disorders of consciousness. *Clin. Neurophysiol.* 129, 1083–1089.
- Tomaka, J., Blascovich, J., Kibler, J., Ernst, J.M., 1997. Cognitive and physiological antecedents of threat and challenge appraisal. *J. Pers. Soc. Psychol.* 73, 63–72.
- Tomkins, S., 1962. *Affect Imagery Consciousness: Volume I: The Positive Affects*. Springer Publishing Company.
- Tononi, G., Cirelli, C., 2006. Sleep function and synaptic homeostasis. *Sleep Med. Rev.* 10, 49–62.
- Tooby, J., Cosmides, L., 1990. On the universality of human nature and the uniqueness of the individual: the role of genetics and adaptation. *J. Pers.* 58, 17–67.
- Tooby, J., Cosmides, L., 1992. The psychological foundations of culture. In: Barkow, J.H., Cosmides, L., Tooby, J. (Eds.), *The Adapted Mind: Evolutionary Psychology and the Generation of Culture*. Oxford University Press, New York.
- Tottenham, N., Hare, T.A., Quinn, B.T., McCarry, T.W., Nurse, M., Gilhooly, T., Millner, A., Galvan, A., Davidson, M.C., Eigsti, I.M., Thomas, K.M., Freed, P.J., Booma, E.S., Gunnar, M.R., Altemus, M., Aronson, J., Casey, B.J., 2010. Prolonged institutional rearing is associated with atypically large amygdala volume and difficulties in emotion regulation. *Dev. Sci.* 13, 46–61.
- Touroutoglou, A., Lindquist, K.A., Dickerson, B.C., Barrett, L.F., 2015. Intrinsic connectivity in the human brain does not reveal networks for 'basic' emotions. *Soc. Cogn. Affect. Neurosci.* 10, 1257–1265.
- Tsakiris, M., Critchley, H., 2016. Interoception beyond homeostasis: affect, cognition and mental health. *Philos. Trans. R. Soc. Lond. B: Biol. Sci.* 371.
- Udupa, K., Sathyaprabha, T.N., Thirthalli, J., Kishore, K.R., Lavekar, G.S., Raju, T.R., Gangadhar, B.N., 2007. Alteration of cardiac autonomic functions in patients with major depression: a study using heart rate variability measures. *J. Affect. Disord.* 100, 137–141.
- Uusberg, A., Uibo, H., Kreegipuu, K., Allik, J., 2013. EEG alpha and cortical inhibition in affective attention. *Int. J. Psychophysiol.* 89, 26–36.
- Vachon-Preseu, E., Centeno, M.V., Ren, W., Berger, S.E., Tetreault, P., Ghantous, M., Baria, A., Farmer, M., Baliki, M.N., Schnitzer, T.J., Apkarian, A.V., 2016. The emotional brain as a predictor and amplifier of chronic pain. *J. Dent. Res.* 95, 605–612.
- van Dyck, Z., Voge, C., Blechert, J., Lutz, A.P., Schulz, A., Herbert, B.M., 2016. The water load test as a measure of gastric interoception: development of a two-stage protocol and application to a healthy female population. *PLoS ONE* 11, e0163574.
- van Elk, M., Lenggenhager, B., Heydrich, L., Blanke, O., 2014. Suppression of the auditory N1-component for heartbeat-related sounds reflects interoceptive predictive coding. *Biol. Psychol.* 99, 172–182.
- van Overveld, M., 2016. Emotion regulation can be costly. A study on the effects of emotion regulation strategies on impulsive purchases in consumers. *Innov. Market.* 12, 41–49.
- van Overveld, M., Borg, C., 2015. Brief emotion regulation training facilitates arousal control during sexual stimuli. *J. Sex Res.* 52, 996–1005.

- van Overveld, W.J., de Jong, P.J., Peters, M.L., 2009. Digestive and cardiovascular responses to core and animal-reminder disgust. *Biol. Psychol.* 80, 149–157.
- VanElzakker, M.B., 2013. Chronic fatigue syndrome from vagus nerve infection: a psychoneuroimmunological hypothesis. *Med. Hypotheses* 81, 414–423.
- Vitasari, P., Wahab, M.N.A., Herawan, T., Sinnadurai, S.K., 2011. Psychophysiological treatment in reduced anxiety with biofeedback training for university students. *Procedia* 30, 629–633.
- Volokhov, R.N., Demaree, H.A., 2010. Spontaneous emotion regulation to positive and negative stimuli. *Brain Cogn.* 73, 1–6.
- Vuilleumier, P., 2005. How brains beware: neural mechanisms of emotional attention. *Trends Cogn. Sci.* 9, 585–594.
- Vytal, K., Hamann, S., 2010. Neuroimaging support for discrete neural correlates of basic emotions: a voxel-based meta-analysis. *J. Cogn. Neurosci.* 22, 2864–2885.
- Wager, T.D., Phan, K.L., Liberzon, I., Taylor, S.F., 2003. Valence, gender, and lateralization of functional brain anatomy in emotion: a meta-analysis of findings from neuroimaging. *Neuroimage* 19, 513–531.
- Wager, T.D., van Ast, V.A., Hughes, B.L., Davidson, M.L., Lindquist, M.A., Ochsner, K.N., 2009. Brain mediators of cardiovascular responses to social threat, part II: prefrontal-subcortical pathways and relationship with anxiety. *Neuroimage* 47, 836–851.
- Wald, J., Taylor, S., 2008. Responses to interoceptive exposure in people with posttraumatic stress disorder (PTSD): a preliminary analysis of induced anxiety reactions and trauma memories and their relationship to anxiety sensitivity and PTSD symptom severity. *Cogn. Behav. Therapy* 37, 90–100.
- Walker, M.P., van der Helm, E., 2009. Overnight therapy? The role of sleep in emotional brain processing. *Psychol. Bull.* 135, 731–748.
- Wallace, J.C., Edwards, B.D., Shull, A., Finch, D.M., 2009. Examining the consequences in the tendency to suppress and reappraise emotions on task-related job performance. *Hum. Perform.* 22, 23–43.
- Waller, B.M., Vick, S.J., Parr, L.A., Bard, K.A., Pasqualini, M.C., Gothard, K.M., et al., 2006. Intramuscular electrical stimulation of facial muscles in humans and chimpanzees: Duchenne revisited and extended. *Emotion* 6, 367–382.
- Watkins, L.R., Maier, S.F., 2000. The pain of being sick: implications of immune-to-brain communication for understanding pain. *Annu. Rev. Psychol.* 51, 29–57.
- Wehrwein, E.A., Orer, H.S., Barman, S.M., 2016. Overview of the anatomy, physiology, and pharmacology of the autonomic nervous system. *Compr. Physiol.* 6, 1239–1278.
- Wei, Y., Ramautar, J.R., Colombo, M.A., Stoffers, D., Gomez-Herrero, G., van der Meijden, W.P., Te Lindert, B.H., van der Werf, Y.D., Van Someren, E.J., 2016. I keep a close watch on this heart of mine: increased interoception in insomnia. *Sleep* 39, 2113–2124.
- Weinstein, N., Brown, K.W., Ryan, R.M., 2009. A multi-method examination of the effects of mindfulness on stress attribution, coping, and emotional well-being. *J. Res. Pers.* 43, 374–385.
- Westerhaus, M.J., Loewy, A.D., 2001. Central representation of the sympathetic nervous system in the cerebral cortex. *Brain Res.* 903, 117–127.
- Wiens, S., 2005. Interoception in emotional experience. *Curr. Opin. Neurol.* 18, 442–447.
- Witvliet, C.V., Vrana, S.R., 1995. Psychophysiological responses as indices of affective dimensions. *Psychophysiology* 32, 436–443.
- Wohleb, E.S., McKim, D.B., Sheridan, J.F., Godbout, J.P., 2014. Monocyte trafficking to the brain with stress and inflammation: a novel axis of immune-to-brain communication that influences mood and behavior. *Front. Neurosci.* 8, 447.
- Wojtecki, L., Petri, D., Elben, S., Hirschmann, J., Yelnik, J., Eickhoff, S., Vesper, J., Schnitzler, A., 2014. Modulation of central thalamic oscillations during emotional-cognitive processing in chronic disorder of consciousness. *Cortex* 60, 94–102.
- Wolf, O.T., 2008. The influence of stress hormones on emotional memory: relevance for psychopathology. *Acta Psychol. (Amst)* 127, 513–531.
- Wood, J.D., Alpers, D.H., Andrews, P.L., 1999. Fundamentals of neurogastroenterology. *Gut* 45 (Suppl. 2), II6–II16.
- Woolley, J.D., Strobl, E.V., Sturm, V.E., Shany-Ur, T., Poorzand, P., Grossman, S., Nguyen, L., Eckart, J.A., Levenson, R.W., Seeley, W.W., Miller, B.L., Rankin, K.P., 2015. Impaired recognition and regulation of disgust is associated with distinct but partially overlapping patterns of decreased gray matter volume in the ventroanterior insula. *Biol. Psychiatry* 78, 505–514.
- Wright Jr., K.P., Drake, A.L., Frey, D.J., Fleschner, M., Desouza, C.A., Gronfier, C., Czeisler, C.A., 2015. Influence of sleep deprivation and circadian misalignment on cortisol, inflammatory markers, and cytokine balance. *Brain. Behav. Immun.* 47, 24–34.
- Wu, Y., Baker, C.L., Tenenbaum, J.B., Schulz, L.E., 2018. Rational inference of beliefs and desires from emotional expressions. *Cogn. Sci.* 42, 850–884.
- Yao, S., Becker, B., Zhao, W., Zhao, Z., Kou, J., Ma, X., Geng, Y., Ren, P., Kendrick, K.M., 2018. Oxytocin modulates attention switching between interoceptive signals and external social cues. *Neuropsychopharmacology* 43, 294–301.
- Yarkoni, T., Poldrack, R.A., Nichols, T.E., Van Essen, D.C., Wager, T.D., 2011. Large-scale automated synthesis of human functional neuroimaging data. *Nat. Methods* 8, 665–670.
- Yaroslavsky, I., Bylsma, L.M., Rottenberg, J., Kovacs, M., 2013. Combinations of resting RSA and RSA reactivity impact maladaptive mood repair and depression symptoms. *Biol. Psychol.* 94, 272–281.
- Yaroslavsky, I., Rottenberg, J., Bylsma, L.M., Jennings, J.R., George, C., Bajji, I., Benak, I., Dochnal, R., Halas, K., Kapornai, K., Kiss, E., Makai, A., Varga, H., Vetro, A., Kovacs, M., 2016. Parasympathetic nervous system activity predicts mood repair use and its effectiveness among adolescents with and without histories of major depression. *J. Abnorm. Psychol.* 125, 323–336.
- Yeragani, V.K., Pohl, R., Balon, R., Ramesh, C., Glitz, D., Jung, I., Sherwood, P., 1991. Heart rate variability in patients with major depression. *Psychiatry Res.* 37, 35–46.
- Yoris, A., Esteves, S., Couto, B., Melloni, M., Kichic, R., Cetkovich, M., Favaloro, R., Moser, J., Manes, F., Ibanez, A., Sedeno, L., 2015. The roles of interoceptive sensitivity and metacognitive interoception in panic. *Behav. Brain Funct.* 11, 14.
- Yoris, A., Garcia, A.M., Traiber, L., Santamaria-Garcia, H., Martorell, M., Alifano, F., Kichic, R., Moser, J.S., Cetkovich, M., Manes, F., Ibanez, A., Sedeno, L., 2017. The inner world of overactive monitoring: neural markers of interoception in obsessive-compulsive disorder. *Psychol. Med.* 47, 1957–1970.
- Yoshida, M., Yokoo, H., Mizoguchi, K., Kawahara, H., Tsuda, A., Nishikawa, T., Tanaka, M., 1992. Eating and drinking cause increased dopamine release in the nucleus accumbens and ventral tegmental area in the rat: measurement by in vivo microdialysis. *Neurosci. Lett.* 139, 73–76.
- Young, L.J., Lim, M.M., Gingrich, B., Insel, T.R., 2001. Cellular mechanisms of social attachment. *Horm. Behav.* 40, 133–138.
- Young, L.J., Wang, Z., Insel, T.R., 1998. Neuroendocrine bases of monogamy. *Trends Neurosci.* 21, 71–75.
- Yu, T., Lang, S., Vogel, D., Markl, A., Muller, F., Kotchoubey, B., 2013. Patients with unresponsive wakefulness syndrome respond to the pain cries of other people. *Neurology* 80, 345–352.
- Zadra, A.L., Nielsen, T.A., Donderi, D.C., 1998. Prevalence of auditory, olfactory, and gustatory experiences in home dreams. *Percept. Mot. Skills* 87, 819–826.