



Development of supercritical fluid extraction for the recovery of betacyanins from red pitaya fruit (*Hylocereus polyrhizus*) peel: a source of natural red pigment with potential antioxidant properties

¹Fathordoobady, F., ^{2,3}Manap, M. Y., ²Selamat, J. and ¹Singh, A. P.

¹Faculty of Land and Food Systems, University of British Columbia, Vancouver, Canada

²Faculty of Food Science and Technology, Universiti Putra Malaysia, Selangor, Malaysia

³Halal Products Research Institute, Universiti Putra Malaysia, Selangor, Malaysia

Article history

Received: 1 December, 2017

Received in revised form:

22 December, 2018

Accepted: 1 March, 2019

Abstract

In the present work, supercritical fluid extraction (SFE) with CO₂ as solvent and EtOH/water (v/v) as co-solvent was optimised by applying 2³ factorial experimental design for the extraction of betacyanins from red pitaya fruit (*Hylocereus polyrhizus*) peel. Three independent variables of pressure (20-30 MPa), temperature (40-60°C) and co-solvent concentration (10-20%) were chosen for response variables. With the 2 mL/min flow rate of CO₂, the dynamic time of extraction was found to be 90 min. The linear effects of main factors and interactions were evaluated. The calculated response surface model for the pressure/temperature was found to be significant for all the dependent variables. At optimal condition of SFE, the response variables were assessed as maximum extraction yield of 4.09 ± 0.69%, total betacyanins content of 25.49 ± 1.54 mg/100 mL, redness (*a**) of 58.18 ± 0.82, and IC₅₀ (antioxidant activity) of 1.34 ± 0.12 mg/mL for the experimental peel extracts. The optimal levels of independent variables were validated for the experimental responses as predicted by the mathematical model. The reliability of this method was confirmed as there was no significant difference between experimental and predicted values. The HPLC-MS profile of betacyanins extract comprised of both acylated and non-acylated betacyanins constituents.

© All Rights Reserved

Keywords

Red pitaya

Hylocereus polyrhizus

Betacyanins

Supercritical fluid extraction

Factorial design

Antioxidant activity

Introduction

Betalains have recently attracted researchers' attention because of their desirable colour and bioactive properties (Osorio-Esquivel *et al.*, 2011). To date, 75 structures of betalains comprising yellow betaxanthins and reddish purple betacyanins have been identified (Stintzing and Carle, 2007; Khan and Giridhar, 2015). Betacyanins [conjugates of betalamic acid with cyclo-3-(3, 4-dihydroxyphenylalanine)] as significant components of betalains are suitable for colouring low acid foodstuffs over anthocyanins because they retain their colourant ability at pH 3-7. The most characteristic red-violet betacyanin is betanin (betanidin 5-O-β-glucoside), the predominant betalain in the red beet (*Beta vulgaris*). Due to the microbial carry over, nitrate accumulation and earthy smell caused by pyragine and geosmin in betanin obtained from the red beet (MoBhammer *et al.*, 2005), the search for alternative plant sources of betacyanins seems indispensable.

Fruits from the *Cactaceae* family, including *Hylocereus*, are excellent sources of betacyanins pigment (Lim *et al.*, 2011). In Malaysia, the demand for consumption of red pitaya fruit has been substantially increased because of the unique appearance, attractive red purple colour and bioactive properties (Lim *et al.*, 2010; Nurul and Asmah, 2014). The red pitaya peel which accounts for around 33% of the whole fruit's weight is considered as a rich source of betacyanins and polyphenols with antioxidant activity. Harivaindaran *et al.* (2008), Ding *et al.* (2009) and Jamilah *et al.* (2011) have also verified the colouring potential of red pitaya peel. However, inedible peels, waste products of juice manufacturing, are often discarded during processing.

Betacyanins isolation from plant matrices by applying organic solvents has been highly recommended (Delgado-Vargas *et al.*, 2000). Recently, a microwave-assisted extraction method has been demonstrated for the isolation of betacyanins from red beet (Cardoso-Ugarte *et al.*, 2014), *Bougainvillea*

*Corresponding author.

Email: farah.fathordoobady@ubc.ca

glabra flowers (Maran *et al.*, 2015), and red pitaya (Thirugnanasambandham and Sivakumar, 2017). Despite obtaining high amounts of yield, all of them used organic solvents for the extraction. Since the residue of organic solvents in food products is a food safety issue, many researches focused on representing environmentally safe extraction methods to a variety of bioactive resources (Cardoso-Ugarte *et al.*, 2014). Among novel extraction techniques, the SFE method is a well-known alternative to conventional solvent methods (Nisha *et al.*, 2012). Low temperature of process, rapid mass transfer and high selectivity are some of the superiorities of this method (Pasquali *et al.*, 2008). SFE has been used for obtaining pitaya (*Hylocereus polyrhizus* and *Hylocereus undatus*) peel extract (Luo *et al.*, 2014). However, the major components of the extracts comprised of non-polar triterpenoids and steroids because they incorporated no co-solvent for extraction. We previously reported the efficacy of the supercritical CO₂ extraction technique with EtOH/water as a co-solvent for betacyanins recovery from *Hylocereus polyrhizus* (Fathordoobady *et al.*, 2016).

One of the major features that should be well considered in SFE technique is the optimisation of the process variables, mainly pressure, temperature, time, type and/or percentage of co-solvent. Using the optimum points for variables affecting SFE process can significantly improve the extraction yield and recovery of a target compound. Among the different methods of process development, using experimental designs is one of the best approaches for setting up a robust SFE process and optimising the method (Kassama *et al.*, 2008). To the best of our knowledge, optimisation of SFE variables for the isolation of betacyanins from the peel of red pitaya has not been established thus far, with several works focused on SFE optimisation of anthocyanins. The extraction of bioactive anthocyanins from grape peel (*Vitis labrusca*) was optimised using response surface methodology (RSM) (Ghafoor *et al.*, 2010). The researchers pointed out that the extraction process was remarkably affected by temperature and pressure. Similarly, through investigation of the kinetics of anthocyanins extraction from red cabbage by high pressure CO₂ (Xu *et al.*, 2010), it was found that the temperature and pressure of the process significantly ($p < 0.05$) affected the yield value. In another study, high pressure liquid extraction method with ethanol as a co-solvent was used for the recovery of anthocyanins and other phenolics from jaboticaba skin (Santos *et al.*, 2012). On the optimal conditions, the extraction yield was similar to the solvent method; however, the results of anthocyanins

and total phenolic contents showed 2.15 and 1.66-fold increase, respectively.

To provide helpful information regarding the development of SFE of betacyanins, the effects of pressure, temperature and co-solvent percentage on the yield, betacyanins recovery, colour properties, and antioxidant activity of betacyanins extract were investigated in the present work. A factorial experimental design was used to support the interpretation and discussion of the tests results. A detailed mass profile of betacyanins constituents was also reported.

Materials and methods

Plant sample preparation

Red pitaya fruits were collected from a modern farm in Kluang, Johor, Malaysia at complete ripening stage of 30-35 days after flower anthesis, and manually peeled with a stainless steel knife. The uncoloured parts of the peels were removed prior to drying in an air circulated oven at 42°C for 48 h. The dried samples were cut into approximately 2 cm cubes and preserved in amber screw-cap bottles at -18°C for one month. A specific amount of frozen sample was immediately ground before each run of experiment.

Chemicals and materials

All analytical and HPLC grade solvents (i.e. methanol, ethanol, hydrochloric acid, acetonitrile (ACN), trifluoroacetic acid (TFA), and formic acid) were purchased from Merck Co. (Darmstadt, Germany). Ascorbic acid and 1, 1-diphenyl-2-picrylhydrazyl (DPPH) were provided by Sigma Aldrich Co. (USA). Authentic betacyanins standard, comprised of betanin and isobetanin, was supplied by Hangzhou Sage Chemical Co. (Beijing, China).

Supercritical Fluid Extraction (SFE)

A laboratory scale system of a SFE (Jasco BP-1580-81, Tokyo, Japan) was used for betacyanins recovery (Figure 1). The pre-cooled liquefied CO₂ (99.9% purity) was pumped to the system at a flow rate of 2 mL/min to reach the desired pressure controlled by a back-pressure regulator (BPR). For each run, a 50 mL volume stainless steel extraction vessel, placed in a temperature regulated water bath, was filled with 5.00 ± 0.01 g ground sample (particle size > 0.60 mm, mesh 30). To avoid clogging, samples were wrapped in a coffee filter and fixed with defatted glass wood pieces. Co-solvent (EtOH/water 10/90 v/v) was spiked to the sample prior to each run of extraction. The SFE experiments were

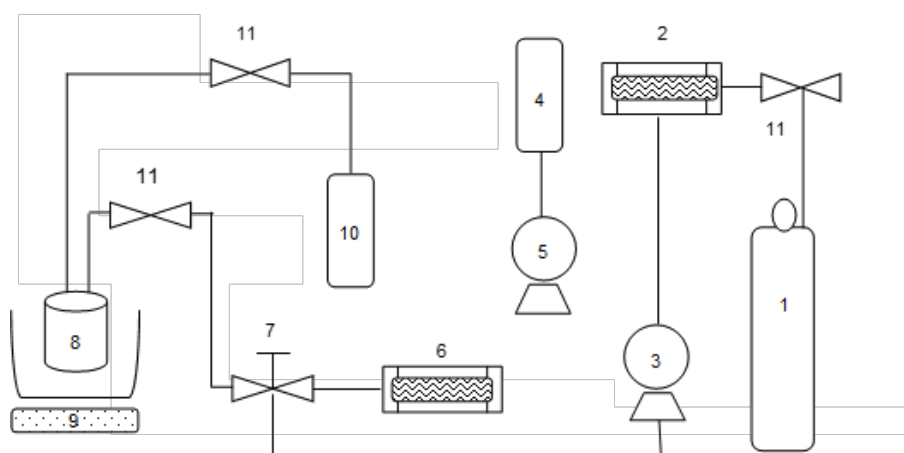

Figure 1. Laboratory scale SFE apparatus: (1) CO₂ cylinder, (2) CO₂ chiller, (3) CO₂ HPLC pump, (4) co-solvent vessel, (5) co-solvent HPLC pump, (6) temperature regulator, (7) back pressure regulator, (8) stainless steel sample extraction vessel, (9) thermostatic water bath, (10) sample collector, (11) valve.

performed at pressures 20-30 MPa and temperatures 40-60°C (Vatai *et al.*, 2009). In the present work, the mixture of EtOH/water 10/90 (v/v), an efficient co-solvent for betacyanins extraction from *Hylocereus polyrhizus* (Fathordoobady *et al.*, 2016), was used in the amount of 10-20%. During the 90 min dynamic extraction, betacyanins extract was collected through a collection unit at ambient temperature. To remove the small residue of ethanol, collected pigment extracts were rotary evaporated by a Laborota 4000 system (Schwabach, Germany) and freeze dried before further analyses. The SFE experiments were repeated three times.

Measurement of extraction yield

Equivalent extract volume (15 mL) from each SFE experiments were freeze-dried. The extraction yield (%), the mean of three distinct experiments, was calculated based on the weight percent of freeze-dried pigment extract (W) over the initial weight of the dried peel sample (W₀) (Santos *et al.*, 2012) using Eq. 1:

$$\text{Yield (\%)} = W/W_0 \times 100 \quad (\text{Eq. 1})$$

where W = weight of dried peel extract, and W₀ = initial weight of the sample.

Determination of total betacyanins content

The total betacyanins content of the red pitaya extract was measured following the method described by Stintzing *et al.* (2002). Using UV-Vis Spectrophotometer (Genesys 10, Thermo Scientific Co.), the maximum absorbance of diluted aqueous

extracts of red pitaya was recorded at 538 nm. The total betacyanins content, betanin equivalent (Be), was defined using Eq. 2:

$$\text{Total betacyanins content (mgBe/100 mL)} = \frac{A_{538} (\text{MW}) V (\text{DF}) \times 100}{\epsilon L} \quad (\text{Eq. 2})$$

where A = absorbance value ($\lambda = 538$), MW = molecular weight of betanin (550 g/mol), V = volume of pigment extract, DF = dilution factor, ϵ = mean molar absorptivity (60,000 mol/L/cm), and L = length of the path (1 cm). All tests were made in triplicate, and the means \pm standard deviation (SD) were calculated.

Analysis of colour properties

Redness (a^*) of pigment extracts was directly measured by a HunterLab Colorimeter (Reston, VA, USA) with an Ultra-scan Pro Spectrophotometer and the EasyMatch QC software, version 3.6. Illuminant and observer angle were adjusted at D65 and 10°. According to Stintzing *et al.* (2005), in the CIE $L^* a^* b^*$ system of colour analysis, a^* ($-a^*$ = green, $+a^*$ = red) is a significant colour attribute affecting C^* (chroma) and H° (hue angle). All tests were made in triplicate, and the means \pm standard deviation (SD) were calculated.

Inhibition concentration assay

Inhibition concentration (IC₅₀), the mean of sample concentration required to inhibit the initial radical scavenging activity by 50%, was calculated using standard curve (dose-response plot) of DPPH absorbance versus sample concentration (Nurliyana

et al., 2010). For this purpose, DPPH antioxidant activity of the extract was first determined according to the method described by Wu *et al.* (2006). The mean results acquired from five replications were compared to the antioxidant activity of vitamin C as standard.

HPLC/LC-ESI-MS/MS analysis

The HPLC profile of betacyanins extracts from red pitaya fruit peel was monitored according to Stintzing *et al.* (2002) and Esquivel *et al.* (2007) with minor modification in gradient of elution. A PDA-HPLC system (Agilent, series 1200, Santa Clara, US) with a RP-C₁₈ column (250 × 4.6 mm, 5 μm, Lichrocart, Merck, Darmstadt, Germany) was used at condition of 538 nm, 25°C and 1 mL/min flow rate. Formic acid 0.2% (v/v) and acetonitrile 80% (v/v) were used as mobile phases A and B, respectively. All tests were made in triplicate, and the means ± standard deviation (SD) were calculated. Miner identifications of betacyanins were then performed according to Esquivel *et al.* (2007) and Wybraniec *et al.* (2007) by using the LC/MS system series 1290 infinity UHPLC, coupled with Triple Q LC/MS series 6410 (Agilent Technologies, Santa Clara, US) operating with the Electrospray Ionisation (ESI) source in the positive mode. The system was equipped with Agilent MassHunter Qualitative Analysis Software. Flow rate of dry gas and pressure of the nebuliser were set at 10 mL/min and 45 psi with the temperature of 350°C and electrospray voltage of 4 KV. The collision gas was Helium (4.1 × 10⁻⁹ bar), and collision-induced separation spectra were acquired with fragmentation amplitude of 1.2 V (MS/MS). The column was Agilent Zorbax SB-C18 Narrow Bore (2.1 × 150 mm, 3.5 μm).

Experimental design

The effects of variation levels of three independent variables: pressure 20-30 MPa, temperature 40-60°C and co-solvent percent 10-20% on the four responses of extraction yield (%), total betacyanins content (mg/100 ml), redness (*a**), and antioxidant activity (IC₅₀) of pigment extract were studied by using a 2³ full factorial experimental design. Twenty runs of the experiment, including four trials for replication of centre points (to evaluate the pure error) and two trials for replication of axial points were performed. Experiments were randomised to reduce the unexplained effects of variability in the responses. Different treatments were created based on a completely randomised design (CRD). All the test analyses were performed in triplicate. The data were statistically analysed by one-way ANOVA and

reported as mean ± SD. The significant difference (*p* < 0.05) among means was determined by Tukey's test. The significant degree of independent variables was defined by F-ratio and *p*-value (Mirhosseini and Amid, 2012). A first-order polynomial model for predicting the variation of response variables was defined using Eq. 3:

$$Y = \beta_0 + \sum_{i=1}^3 \beta_i x_i + \sum_{i=1}^{n3} \sum_{j>1}^3 \beta_{ij} x_i x_j + \beta_{ijk} x_i x_j x_k \quad (\text{Eq. 3})$$

where Y = response variable, β₀ = constant, β_{*i*}, β_{*ij*} and β_{*ijk*} = coefficients of regression for linearity and interaction effects, and *x_i*, *x_j* and *x_k* = independent variables.

To find the best SFE condition for desirable values of response variables including yield (%), total betacyanins content (mg/100 mL), redness (*a**) and IC₅₀ (mg/mL) the numerical optimisation was performed. For better conception of the significant interaction effects (*p* < 0.05) of process, graphical optimisation was carried out by 3D plotting of the reduced response models. The mathematical model produced by factorial design was verified by performing experiments in given optimal conditions of extraction and data were then analysed by *T*-test. The Minitab statistical software version 16.0 (Minitab® Statistical Software) was used for the experimental design matrix, analysis of data and optimisation procedure.

Results and discussion

Optimising the process of extraction using factorial design

The ranges of independent variables of pressure, temperature and co-solvent for the extraction of betacyanins pigment shown in Table 1 were determined based on the screening experiment and the yield and total betacyanins content obtained through trial experiments. Preliminary studies were also performed to find the efficient time of extraction. It was found that the major part of the pigment extract (yield: up to 4.11%; total betacyanins content: up to 25.42 mg/100 mL) was isolated through the first 90 min of the dynamic extractions (Figure 2). At all the pressure levels, the extraction yield values reached a plateau when the process continued for more than 90 min; however, the total betacyanins content of pigment extracts significantly decreased (*p* < 0.05) during 120-180 min of extraction. Therefore, 90 min was selected as an efficient extraction time. The

Table 1. Factorial experimental design and responses results for SFE of red pitaya fruit (*Hylocereus polyrhizus*) peel.

Variable level	Variable		
	Extraction pressure (MPa)	Extraction temperature (°C)	Co-solvent (%)
Low level	20	40	10
Medium level	25	50	15
Maximum level	30	60	20

Test run	Uncoded factor			Analytical test			
	Pressure (MPa)	Temperature (°C)	Co-solvent (%)	Yield (%)	^a Be (mg/100 mL)	^{ba*} (redness)	^c IC ₅₀ (mg/mL)
1	20	40	20	2.21 ± 0.11	14.25 ± 1.33	46.6 ± 0.1	2.76 ± 0.08
2	20	60	20	2.45 ± 0.09	16.55 ± 1.46	48.7 ± 0.0	2.85 ± 0.15
3	20	40	10	2.15 ± 0.13	13.78 ± 0.98	45.6 ± 0.2	3.47 ± 0.18
4	30	60	10	2.58 ± 0.15	17.52 ± 0.89	44.4 ± 0.1	2.15 ± 0.09
5	30	40	10	3.66 ± 0.08	19.18 ± 1.02	57.6 ± 0.1	2.03 ± 0.05
6	20	40	20	2.25 ± 0.07	14.56 ± 0.95	46.7 ± 0.3	2.96 ± 0.13
7c*	25	50	15	3.91 ± 0.12	25.66 ± 0.99	59.3 ± 0.0	1.44 ± 0.07
8	30	60	10	2.67 ± 0.07	17.81 ± 1.04	44.6 ± 0.2	2.29 ± 0.18
9	20	60	10	2.31 ± 0.09	15.54 ± 0.34	43.7 ± 0.1	3.21 ± 0.20
10	30	40	20	3.47 ± 0.21	20.25 ± 0.28	59.5 ± 0.0	1.45 ± 0.08
11*	25	50	15	3.85 ± 0.23	25.42 ± 0.63	58.9 ± 0.1	1.33 ± 0.11
12*	25	50	15	3.97 ± 0.18	25.86 ± 0.56	59.4 ± 0.2	1.21 ± 0.14
13	30	60	20	3.11 ± 0.16	18.97 ± 0.78	52.5 ± 0.3	1.75 ± 0.09
14	30	60	20	3.16 ± 0.22	19.26 ± 0.85	52.7 ± 0.0	1.59 ± 0.15
15	30	40	20	3.69 ± 0.31	19.99 ± 0.91	59.4 ± 0.1	1.57 ± 0.14
16	20	60	10	2.38 ± 0.17	15.87 ± 0.45	43.9 ± 0.1	2.94 ± 0.07
17	20	60	20	2.51 ± 0.19	17.02 ± 0.26	48.8 ± 0.2	3.04 ± 0.13
18	20	40	10	2.23 ± 0.08	14.04 ± 0.11	45.7 ± 0.2	3.59 ± 0.08
19	30	40	10	3.62 ± 0.15	18.98 ± 0.33	57.6 ± 0.0	2.14 ± 0.10
20*	25	50	15	4.01 ± 0.28	25.74 ± 0.48	59.4 ± 0.1	1.38 ± 0.09

^aBetacyanins^bRedness coordinate^cInhibition concentration (mg/mL)

*Centre point

Data are means ± SD of three measurements ($n = 3$).

results of an application of the specified 2³ factorial design for the optimisation of three independent variables, namely extraction pressure (MPa), temperature (°C) and co-solvent (%), for the four responses of extraction yield (%), total betacyanins content (mg/100 mL), redness (a^*), and antioxidant property (IC₅₀) of the pigment extracts are presented in Table 1.

Effects of the SFE variables on the yield (y_1) of the extract

The extraction yield (%) was recorded from 2.15 to 4.01% in the studied ranges of the extraction independent variables (Table 1). The linear regression equation with polynomials describing the first-order main effects of factors (x_1 , x_2 and x_3) and their interaction effects (x_1x_2 , x_1x_3 , x_2x_3 , and $x_1x_2x_3$)

was formed to predict the extraction yield (y_1) as a response to factors. In generating this equation, the significant terms ($p < 0.05$) were included and the insignificant terms ($p > 0.05$) were omitted as follows:

$$y_1 = 2.7956 + 0.4844x_1 - 0.1494x_2 + 0.0956x_3 - 0.2506x_1x_2 + 0.0519x_1x_3 + 0.0656x_2x_3 + 0.0419x_1x_2x_3 \quad (\text{Eq. 4})$$

According to Eq. 4, all the main independent variables and their combinations had significant effects ($p < 0.05$) on the (y_1) response. The yield value was positively proportional to the pressure (x_1) and co-solvent (x_3). However, the temperature (x_2) showed negative effect. The regression analysis and ANOVA results (Table 2) represented the validity

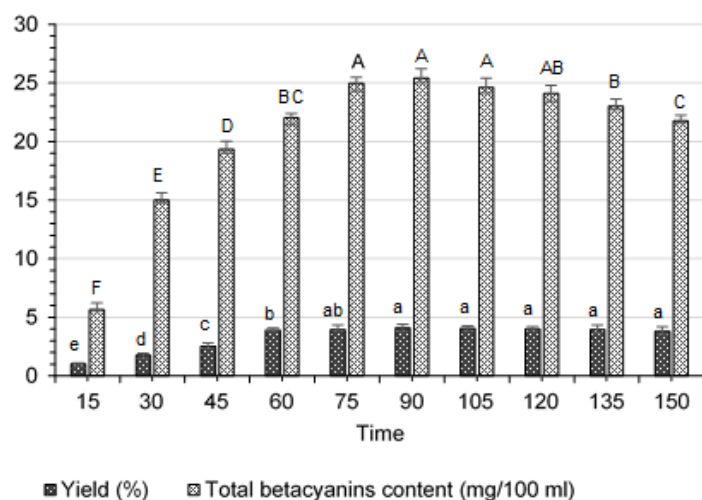

Figure 2. The effect of the time of SFE (pressure: 25 MPa; temperature: 50°C and co-solvent: 10%) on the yield (%) and total betacyanins content (mg/100 mL) of the peel of red pitaya fruit (*Hylocereus polyrhizus*). Data are means \pm SD of three measurements ($n = 3$). Different capital and small letters indicate significant difference ($p < 0.05$) between total betacyanins and yield, respectively.

Table 2. Regression analysis and ANOVA for SFE of red pitaya fruit (*Hylocereus polyrhizus*) peel.

Source	^a DF				Mean Squares				F-ratio <i>p</i> -Value			
	^b Y	^c Be	^d a*	^e IC ₅₀	Y	Be	a*	IC ₅₀	Y	Be	a*	IC ₅₀
Residual	11	11	11	11	0.002	0.044	0.018	0.013				
Pure error	11	11	11	11	0.002	0.044	0.018	0.013				
x_1	1	1	1	1	3.753	57.571	215.502	6.076	1338.51 0.000*	1297.02 0.000*	12296.86 0.000*	461.35 0.000*
x_2	1	1	1	1	0.357	0.770	96.629	0.001	127.30 0.000*	17.35 0.002*	5513.77 0.000*	0.09 0.766
x_3	1	1	1	1	0.146	4.131	63.601	0.931	52.17 0.000*	93.07 0.000*	3629.14 0.000*	70.71 0.000*
$x_1 x_2$	1	1	1	1	1.005	10.874	102.820	0.112	358.35 0.000*	244.97 0.000*	5867.02 0.000*	8.52 0.000*
$x_1 x_3$	1	1	1	1	0.043	0.209	3.901	0.027	15.35 0.002*	4.72 0.053	222.57 0.000*	2.07 0.000*
$x_2 x_3$	1	1	1	1	0.063	0.248	25.857	0.081	24.57 0.000*	5.58 0.038*	1475.45 0.000*	6.17 0.000*
$x_1 x_2 x_3$	1	1	1	1	0.028	0.008	1.221	0.065	10.00 0.009*	0.17 0.686	69.67 0.000*	4.94 0.000*
		Y	Be	a*	IC ₅₀							
**R ²		0.9968	0.9984	0.9998	0.9875							
R ² (pred)		0.9905	0.9944	0.9994	0.9551							

^aDegree of freedom

^bYield (%)

^cBetacyanins (mg/100 mL)

^dRedness coordinate

^eInhibition concentration (mg/mL)

x_1 : pressure (MPa); x_2 : temperature (°C); x_3 : co-solvent (%)

*Significant term

** $\alpha = 0.05$

and good prediction capability of the fit model with the coefficient determination (R^2) of 0.9968. Based on F-ratio analysis, the pressure and the co-solvent showed the highest and the least significant effects on the extraction yield (y_1), respectively. The positive effect of pressure could be attributed to the increased amount of density and diffusivity of CO_2 in higher pressure. This led to the strengthening of the solvating power of supercritical CO_2 . On the other hand, the temperature of SFE process is a factor influencing the solubility of solutes in CO_2 by changing density or solute vapour pressure. When operating at pressures near to the critical point, density represents higher influence on the solvation power of supercritical CO_2 than the vapour pressure. Hence, elevated temperature may decrease the extraction yield by reduction of density (Martinez, 2007). In the present work, with the maximum pressure of 30 MPa, the density seemed to have higher impact on the solvation power than the solute vapour pressure. Therefore, the negative effect of temperature on the yield was predominant.

The regression equations on the linear model were tested using 3D graphical response plotting that helped to understand the effect of pressure (x_1) and temperature (x_2), as the most significant factors ($p < 0.05$), and their optimum combinations for higher extraction yield (y_1) of the peel extract. The 3D plots were obtained by plotting the responses on the z axis against two factors (pressure and temperature) while other independent variables (co-solvent %) were kept constant. As shown in Figure 3, at pressure below 30 MPa, there was an improvement in extraction yield (y_1) by increasing temperature up to 50°C. However, the yield decreased at temperatures higher than 50°C. The optimum condition for the extraction yield (%) of the peel was achieved at 25 MPa and 50°C. It can be noted that raising the temperature of extraction up to 50°C promoted the yield amount through increasing mass transfer of the solute (betacyanins) in the matrix and/or from the matrix to the fluid. In all levels of pressure, applying 60°C led to decreasing response (y_1). Dissimilar to our findings, Yi *et al.* (2009) found no significant interaction effect from pressure and temperature on lycopene yield during their study on SFE of lycopene from tomato skin and seed. They achieved higher lycopene yield through increasing both the temperature and pressure. They found that the temperature dependence of yield was higher than that of pressure dependence.

Ghafoor *et al.* (2010) reported the same effects of pressure and temperature on recovery of anthocyanin bioactive compounds from grape peel at 14-17 MPa pressure and 37-46°C temperature. Kassama *et al.* (2008) had also investigated the significant effect

($p < 0.05$) of pressure and temperature and their combined effect on all-trans lycopene yield in SFE from tomato skin. Unlike our findings, they found that modifier concentration (ethanol %) had no direct significant effect; however, in combination with temperature variable, ethanol percentage showed synergistic effect on lycopene yield. In another research on the extraction of phenolic compounds of anthocyanins from jaboticaba skins with pressurised ethanol (Santos *et al.*, 2012), the extraction yield was significantly improved ($p < 0.05$) just by enhancing the temperature from 40 to 80°C. It was referred to as increasing the diffusion rate, which occurred up to 80°C leading to improvement of the anthocyanins solubility in solvent. They found pressure insignificant ($p > 0.05$) at the range of 5 - 10 MPa.

Effects of the SFE variables on the total betacyanins content (y_2) of the extract

Experimental results for the total betacyanins content of the peel extracts (13.78-25.86 mg/100 mL) implied that the response (y_2) depended on the extraction pressure, temperature and co-solvent (Table 1). With a regression analysis of the data using ANOVA (Table 2), the following model (Eq. 5) was generated for predicting the response variations to independent variables' changes.

$$y_2 = 17.098 + 1.896x_1 + 0.219x_2 + 0.508x_3 - 0.824x_1x_2 + 0.124x_2x_3 \quad (\text{Eq. 5})$$

Eq. 5 revealed that all the main independent variables (x_1 , x_2 and x_3) and the interactions of x_1x_2 and x_2x_3 had impacts on betacyanins content response (y_2). It was found that pressure had the most significant effect ($p < 0.05$) on this response (y_2). Since betacyanins are vacuolar pigments and situated within the cell structure of the plant sources, it is necessary to disrupt the cell structure to liberate it by diffusion process. Higher pressure in SFE leads to higher density and lower viscosity of the solvent (Shi *et al.*, 2009), which can provide better penetration of solvent through the matrix of betacyanins solute. The calculated coefficient (R^2) suggested that the model could predict 99.84% of variability.

The response surface plot generated to define the interaction of pressure (x_1) and temperature (x_2) on the betacyanins content response (y_2) (Figure 3) showed comparable effect to the yield response (y_1). The main solute components in the peel matrix belong to betacyanins. Therefore, the optimum condition for betacyanins content (y_2) occurred at

similar point (25 MPa pressure and 50°C). Close to our findings, Ghafoor *et al.* (2010) and Maran *et al.* (2014) reported the temperatures of 45.2 and 50.0°C for the best recovery of anthocyanins from grape peel and *Syzygium cumini* fruit pulp, respectively. However, the pressure had not exceeded 17 MPa in their researches. Owing to the lower polarity of anthocyanins as compared to betacyanins, the percentage of co-solvent needed for efficient extraction was less than that of the present work. Other investigations regarding bioactive compounds extraction from different sources of plants demonstrated various efficacies of pressure and temperature combinations for anthocyanins recovery. However, all of them emphasised the destructive effects of the elevated temperature on heat sensitive bioactive compounds such as anthocyanins (Xu *et al.*, 2010; Santos and Meireles, 2011; Santos *et al.*, 2012).

Effects of the SFE variables on the redness (a^) (y_3) of the extract*

In the present work, the redness (a^*) of the peel extract as a factor of colour property was recorded in the range of 43.7 ± 0.1 to 59.5 ± 0.2 (Table 2) and was predicted by a linear model equation as follows:

$$y_3 = 5.349 + 3.671x_1 - 2.457x_2 + 1.994x_3 - 2.535x_1x_2 + 0.494x_1x_3 + 1.271x_2x_3 + 0.274x_1x_2x_3 \quad (\text{Eq. 6})$$

Based on Eq. 6, all independent variables and their interactions had significant effect ($p < 0.05$) on the a^* (y_3) response. The subsequent regression analysis and ANOVA (Table 2) indicated that the pressure (x_1) and co-solvent (x_2) factors had the most and the least significant effects on a^* (y_3) response. The value of coefficient determination (R^2) was 0.9998, which implied that the equation had high prediction capability.

Analysing the effects of independent variables on redness (a^*) of the peel pigment extract represented that the interaction effect of pressure and temperature (x_1x_2) had the most significant effect ($p < 0.05$) on the red tonality of the extract. By setting co-solvent percent at 15%, both factors of pressure and temperature showed the similar interaction effect to that of the yield response (Figure 3). It was demonstrated that the redness of red-pitaya extract had a strong relationship to the structure of betacyanins extract (Herbach *et al.*, 2006a). So, any destructive factor leading to betacyanins degradation to the yellowish compounds, such as neobetanins, can

diminish the redness. As can be observed in Figure 3, there was an initial improvement of response at a pressure level lower than 30 MPa by increasing temperature to 50°C; however, in all levels of pressure increasing the temperature up to 60°C led to the final decrease of redness. This pattern is related to the destructive effect of temperature above 50°C on thermal-sensitive phenolic-related compounds such as betacyanins, especially in pressurised systems (Herbach *et al.*, 2006b).

Effects of the SFE variables on the antioxidant activity (IC_{50}) of the extract (y_4)

The values of IC_{50} of the peel extracts as a DPPH antioxidant activity index ranged from 1.21 ± 0.14 to 3.59 ± 0.08 mg/mL. The lower amount of this response, which indicated the higher antioxidant activity of the peel pigment extract, was desired. Based on the coefficients of experimental results and ANOVA, the following linear equation (Eq. 7) was generated for predicting the IC_{50} (y_4) response to variations of independent variables:

$$y_4 = 2.486 - 0.616x_1 - 0.009x_2 - 0.241x_3 + 0.684x_1x_2 + 0.071x_2x_3 - 0.064x_1x_2x_3 \quad (\text{Eq. 7})$$

The significance of the independent variables on the IC_{50} can be determined by referring to the regression analysis and ANOVA presented in Table 2. Pressure (x_1) and co-solvent (x_3) showed the most and the least significant impact ($p < 0.05$) on antioxidant activity of the extract, respectively. Unlike our finding, Ghafoor *et al.* (2010) introduced temperature as the most significant factor ($p < 0.001$) on the antioxidant activity of grape peel. They also found co-solvent had no significant effect ($p > 0.001$) on antioxidant activity of the samples. In the present work, the value of coefficient determination (R^2) for IC_{50} was 0.9875, which represented that the model's fit was compatible.

The regression equation on the linear model was analysed using 3D surface plots of response (Figure 3). When co-solvent concentration was kept constant at 15%, the IC_{50} response (y_4) desirably decreased at 20 and 25 MPa pressure by increasing temperature from 40 to 50°C followed by detrimental increase at 60°C. The latter effect can be referred to as the negative effect of high temperature on betacyanins compounds. Furthermore, there was a slight increase of IC_{50} response at pressure 30 MPa with rising temperature. This increase indicated that this level of pressure was not appropriate for the extraction of betacyanins and other polyphenol compounds from

the peel of red pitaya. This was incompatible with the optimum condition of pressure and temperature for betacyanins recovery from the peel (25 MPa, 50°C). In a research on supercritical CO₂ extraction of phenolic compounds and anthocyanins from blueberry (*Vaccinium myrtillus* L.), Paes *et al.* (2014) found that with constant pressure and temperature of 20 MPa and 40°C, the extracts contained the highest antioxidant activities and phenolic contents when pure ethanol or ethanol + water were used as co-solvents. They reported that using 90% CO₂, 5% water and 5% ethanol led to the best condition for recovery of all functional components.

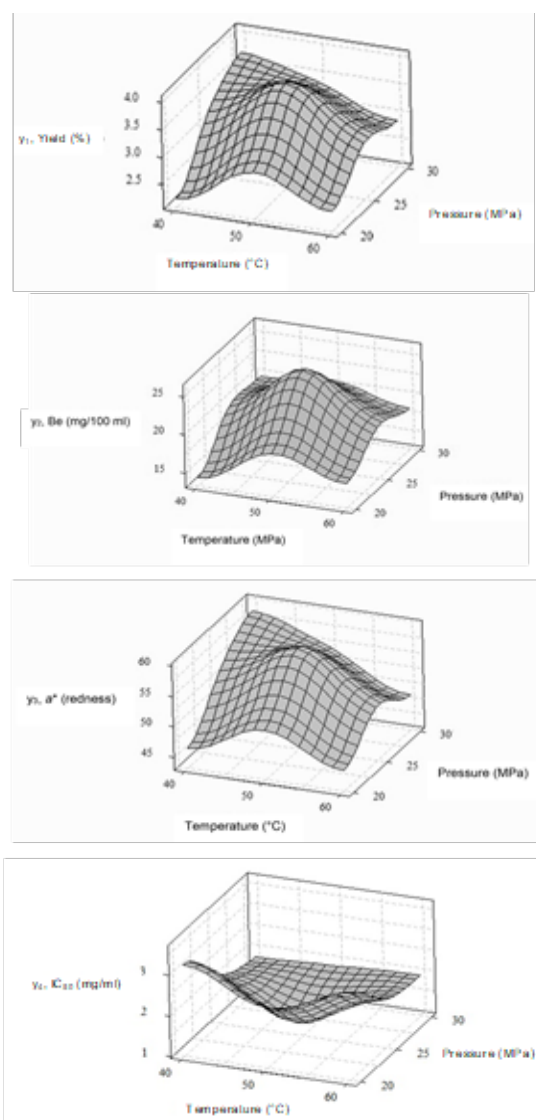

Figure 3. Response surface plot for extraction yield (%), total betacyanins content (mg/100 mL), redness (a^*), and IC_{50} of red pitaya fruit extract (*Hylocereus polyrhizus*) in terms of pressure and temperature (co-solvent was set at 15%).

Verification of the Supercritical Fluid Extraction (SFE) method

Considering the desired values of responses including the maximum yield ($4.09 \pm 0.69\%$), maximum content of betacyanins content (25.49 ± 1.54 mg/100 mL), maximum redness (a^*) (58.18 ± 0.82), and minimum value of IC_{50} (1.34 ± 0.12 mg/mL), the optimal condition of SFE of red-pitaya peel occurred at 25 MPa pressure, 50°C temperature and 15% co-solvent. An independent experiment was carried out to verify the optimum condition of extraction on the desired responses (Table 3). All the responses values obtained from the verification experiment were found to be closed to the full-factorial based prediction, with error value of 1.54% to 3.99%. This indicated a desired performance prospect of the optimised extraction condition.

Table 3. Comparison of experimental and predicted values of extraction yield, total betacyanins content, a^* and IC_{50} using optimal levels of pressure, temperature and co-solvent concentration.

	Yield (%)	¹ Be (mg/100 mL)	² a^*	³ IC_{50}
Experimental	4.09 ± 0.69^a	25.49 ± 1.52^a	58.18 ± 0.82^a	1.34 ± 0.12^a
Predicted	4.26^a	25.89^a	59.29^a	1.31^a
Error (%)	3.99	1.54	1.87	2.23

¹Betacyanins (mg/100 mL)

²Redness coordinate

³Inhibition concentrations (mg/mL)

Data are means \pm SD of three measurements ($n = 3$). Means with different letters in the same column were significantly different ($p < 0.05$).

Betacyanins constituents of red pitaya fruit pigment extract

Based on HPLC analysis of the pigment extract, the total concentration of betacyanins was measured as 23.16 ± 1.08 mg/100 mL (Betanin equivalent). The main individual betacyanins components were detected as betanin (3.91 ± 0.92 mg/100 mL), phyllocactin (12.78 ± 1.53 mg/100 mL) and their corresponding C-15 isomers (15.05 ± 0.49 and 4.44 ± 0.71 mg/100 mL, respectively). The distinct minor betacyanins constituents identified by mass spectrometry comprised of betanidin 5-O-b-sophoroside, apiosylbetanin, hylcoerenin, isobutyryl betanin, and 2'-apiosyl-phyllocactin identified based on their molecular mass and MS/MS fragmentation (Table 4). These betacyanins were previously identified in different species of *Hylocereus* (Kobayashi *et al.*, 2000; Esquivel *et al.*, 2007; Wybraniec *et al.*, 2007).

Table 4. Betacyanin compounds identified in red pitaya fruit (*Hylocereus polyrhizus*) peel.

Compound name	Formula	m/z [M+H] ⁺	
		MS	MS2
Betainin (betanidin 5-O-β glucoside)	C ₂₄ H ₂₆ N ₂ O ₁₃	551	389
Isobetainin	C ₂₄ H ₂₆ N ₂ O ₁₃	551	389
Phyllocactin (6'-O-malonylbetainin)	C ₂₇ H ₂₈ N ₂ O ₁₆	637	593,551
Butyrylbetainin	C ₂₇ H ₂₈ N ₂ O ₁₆	637	551,389
Hylocerenin(3-hydroxy-3-methyl-glutaryl-betainin)	C ₃₀ H ₂₇ N ₂ O ₁₇	695	551,389
Isophyllocactin	C ₂₇ H ₂₈ N ₂ O ₁₆	637	593,551
Isobutyrylbetainin	C ₂₇ H ₂₈ N ₂ O ₁₆	637	551,389
2'-Apiosyl-phylllocactin	C ₃₂ H ₄₀ N ₂ O ₂₀	769	683,551,389
2'-Apiosyl-isophyllocactin	C ₃₂ H ₄₀ N ₂ O ₂₀	769	683,551,389

Conclusion

In the present work, the effects of extraction parameters including pressure, temperature and co-solvent (EtOH/water) concentration for SFE from the peel of red pitaya fruit (*Hylocereus polyrhizus*) were investigated by using a 2³ factorial experimental design. The statistical analysis exhibited significant regression equations ($R^2 > 0.9$) for all of the response variables. This indicated that the factorial model was satisfactorily fitted to the experimental data. The linear effect of pressure, temperature and co-solvent concentration significantly ($p < 0.05$) affected all the response variables, and pressure was found to be the most effective factor. The optimum condition of SFE occurred at 25 MPa pressure, 50°C temperature and 15% co-solvent. The predicted values were reliable to the experimental ones. LC-MS/MS spectrometry of extracted betacyanins identified acylated and non-acylated betacyanins constituents in all of the experimental peel extracts.

Acknowledgement

Authors gratefully acknowledge the personnel in charge at contemporary farm (Kluang, Johor, Malaysia), staff of Functional Food Laboratory and Food Safety Laboratory (Faculty of Food Science and Technology, UPM, Malaysia), and Chemistry Laboratory Assistant (Jeffrey Cheah School, Monash University, Malaysia). The present work was financially supported by the Faculty of Food Science and Technology, UPM, Malaysia.

References

- Cardoso-Ugarte, G. A., Sosa-Morales, M. E., Ballard, T., Liceaga, A. and San Martín-González, M. F. 2014. Microwave-assisted extraction of betalains from red beet (*Beta vulgaris*). *LWT - Food Science and Technology* 59(1): 276-282.
- Delgado-Vargas, F., Jiménez, A. R. and Paredes-López, O. 2000. Natural pigments: carotenoids, anthocyanins, and betalains—characteristics, biosynthesis, processing, and stability. *Critical Reviews in Food Science and Nutrition* 40(3): 173-289.
- Ding, P., Chew, M. K., Suraini, A. A., Lai, O. M. and Janna, O. A. 2009. Red-fleshed pitaya (*Hylocereus polyrhizus*) fruit colour and betacyanin content depend on maturity. *International Food Research Journal* 16: 233-242.
- Esquivel, P., Stintzing, F. C. and Carle, R. 2007. Pigment pattern and expression of colour in fruits from different *Hylocereus* sp. genotypes. *Innovative Food Science and Emerging Technologies* 8(3): 451-457.
- Fathordoobady, F., Mirhosseini, H., Selamat, J. and Manap, M. Y. 2016. Effect of solvent type and ratio on betacyanins and antioxidant activity of extracts from *Hylocereus polyrhizus* flesh and peel by supercritical fluid extraction and solvent extraction. *Food Chemistry* 202: 70-80.
- Ghafoor, K., Park, J. and Choi, Y.-H. 2010. Optimization of supercritical fluid extraction of bioactive compounds from grape (*Vitis labrusca* B.) peel by using response surface methodology. *Innovative Food Science and Emerging Technologies* 11(3): 485-490.
- Harivaindaran, K. V., Rebecca, O. P. S. and Chandran, S. 2008. Study of optimal temperature, pH and stability of dragon fruit (*Hylocereus polyrhizus*). *Pakistan Journal of Biological Sciences* 11(18): 2259-2263.
- Herbach, K. M., Stintzing, F. C. and Carle, R. 2006a. Betalain stability and degradation—structural and chromatic aspects. *Journal of Food Science* 71(4): R41-R50.
- Herbach, K. M., Rohe, M., Stintzing, F. C. and Carle, R. 2006b. Structural and chromatic stability of purple pitaya (*Hylocereus polyrhizus* [Weber] Britton & Rose) betacyanins as affected by the juice matrix and selected additives. *Food Research International* 39(6): 667-677.
- Jamilah, B., Shu, C. E., Kharidah, M., Dzulkify, M. A. and Noranizan, A. 2011. Physico-chemical characteristics of red pitaya (*Hylocereus polyrhizus*) peel. *International Food Research Journal* 18: 279-286.
- Kassama, L. S., Shi, J. and Mittal, G. S. 2008. Optimization of supercritical fluid extraction of lycopene from tomato skin with central composite rotatable design model. *Separation and Purification Technology* 60(3): 278-284.
- Khan, M. I. and Giridhar, P. 2015. Plant betalains: Chemistry and biochemistry. *Phytochemistry* 117: 267-295.

- Kobayashi, N., Schmidt, J., Nimtz, M., Wray, V. and Schliemann, W. 2000. Betalains from Christmas cactus. *Phytochemistry* 54(4): 419-426.
- Lim, H. K., Tan, C. P., Karim, R., Ariffin, A. A. and Bakar, J. 2010. Chemical composition and DSC thermal properties of two species of *Hylocereus* cacti seed oil: *Hylocereus undatus* and *Hylocereus polyrhizus*. *Food Chemistry* 119(4): 1326-1331.
- Lim, S. D., Yusof, Y. A., Chin, N. L., Talib, R. A., Endan, J. and Aziz, M. G. 2011. Effect of extraction parameters on the yield of betacyanins from pitaya fruit (*Hylocereus polyrhizus*) pulps. *Journal of Food, Agriculture and Environment* 9(2): 158-162.
- Luo, H., Cai, Y., Peng, Z., Liu, T. and Yang, S. 2014. Chemical composition and in vitro evaluation of the cytotoxic and antioxidant activities of supercritical carbon dioxide extracts of pitaya (dragon fruit) peel. *Chemistry Central Journal* 8(1): 1-7.
- Maran, J. P., Priya, B. and Manikandan, S. 2014. Modeling and optimization of supercritical fluid extraction of anthocyanin and phenolic compounds from *Syzygium cumini* fruit pulp. *Journal of Food Science and Technology* 51(9): 1938-1946.
- Maran, J. P., Priya, B. and Nivetha, C. V. 2015. Optimization of ultrasound-assisted extraction of natural pigments from *Bougainvillea glabra* flowers. *Industrial Crops and Products* 63: 182-189.
- Martinez, J. L. 2007. *Supercritical fluid extraction of nutraceuticals and bioactive compounds* (1st ed). United States: CRC Press.
- Mirhosseini, H. and Amid, B. T. 2012. Influence of chemical extraction conditions on the physicochemical and functional properties of polysaccharide gum from durian (*Durio zibethinus*) seed. *Molecules* 17(6): 6465-6480.
- Moßhammer, M. R., Stintzing, F. C. and Carle, R. 2005. Colour studies on fruit juice blends from *Opuntia* and *Hylocereus* cacti and betalain-containing model solutions derived therefrom. *Food Research International* 38(8-9): 975-981.
- Nisha, A., Udaya Sankar, K. and Venkateswaran, G. 2012. Supercritical CO₂ extraction of *Mortierella alpina* single cell oil: Comparison with organic solvent extraction. *Food Chemistry* 133(1): 220-226.
- Nurliyana, R., Syed Zahir, I., Mustapha Suleiman, K., Aisyah, M. R. and Kamarul Rahim, K. 2010. Antioxidant study of pulps and peels of dragon fruits: a comparative study. *International Food Research Journal* 17: 367-375.
- Nurul, S. R. and Asmah, R. 2014. Variability in nutritional composition and phytochemical properties of red pitaya (*Hylocereus polyrhizus*) from Malaysia and Australia. *International Food Research Journal* 21(4): 1689-1697.
- Osorio-Esquivel, O., Alicia-Ortiz-Moreno, Álvarez, V. B., Dorantes-Álvarez, L. and Giusti, M. M. 2011. Phenolics, betacyanins and antioxidant activity in *Opuntia joconostle* fruits. *Food Research International* 44(7): 2160-2168.
- Paes, J., Dotta, R., Barbero, G. F. and Martínez, J. 2014. Extraction of phenolic compounds and anthocyanins from blueberry (*Vaccinium myrtillus* L.) residues using supercritical CO₂ and pressurized liquids. *The Journal of Supercritical Fluids* 95: 8-16.
- Pasquali, I., Bettini, R. and Giordano, F. 2008. Supercritical fluid technologies: an innovative approach for manipulating the solid-state of pharmaceuticals. *Advanced Drug Delivery Reviews* 60(3): 399-410.
- Santos, D. T., Veggi, P. C. and Meireles, M. A. A. 2012. Optimization and economic evaluation of pressurized liquid extraction of phenolic compounds from *jaboticaba* skins. *Journal of Food Engineering* 108(3): 444-452.
- Santos, D. T. and Meireles, M. A. A. 2011. Optimization of bioactive compounds extraction from *jaboticaba* (*Myrciaria cauliflora*) skins assisted by high pressure CO₂. *Innovative Food Science and Emerging Technologies* 12(3): 398-406.
- Shi, J., Khatri, M., Xue, S. J., Mittal, G. S., Ma, Y. and Li, D. 2009. Solubility of lycopene in supercritical CO₂ fluid as affected by temperature and pressure. *Separation and Purification Technology* 66(2): 322-328.
- Stintzing, F. C. and Carle, R. 2007. Betalains—emerging prospects for food scientists. *Trends in Food Science and Technology* 18(10): 514-525.
- Stintzing, F. C., Herbach, K. M., Mosshammer, M. R., Carle, R., Yi, W., Sellappan, S., ... and Felker, P. 2005. Color, betalain pattern, and antioxidant properties of cactus pear (*Opuntia* spp.) clones. *Journal of Agricultural and Food Chemistry* 53(2): 442-451.
- Stintzing, F. C., Schieber, A. and Carle, R. 2002. Betacyanins in fruits from red-purple pitaya, *Hylocereus polyrhizus* (Weber) Britton & Rose. *Food Chemistry* 77(1): 101-106.
- Thirugnanasambandham, K. and Sivakumar, V. 2017. Microwave assisted extraction process of betalain from dragon fruit and its antioxidant activities. *Journal of the Saudi Society of Agricultural Sciences* 16(1): 41-48.
- Vatai, T., Škerget, M. and Knez, Ž. 2009. Extraction of phenolic compounds from elder berry and different grape marc varieties using organic solvents and/or supercritical carbon dioxide. *Journal of Food Engineering* 90(2): 246-254.
- Wu, L.-C., Hsu, H.-W., Chen, Y.-C., Chiu, C.-C., Lin, Y.-I. and Ho, J.-A. A. 2006. Antioxidant and antiproliferative activities of red pitaya. *Food Chemistry* 95(2): 319-327.
- Wybraniec, S., Nowak-Wydra, B., Mitka, K., Kowalski, P. and Mizrahi, Y. 2007. Minor betalains in fruits of *Hylocereus* species. *Phytochemistry* 68(2): 251-259.
- Xu, Z., Wu, J., Zhang, Y., Hu, X., Liao, X. and Wang, Z. 2010. Extraction of anthocyanins from red cabbage using high pressure CO₂. *Bioresource Technology* 101(18): 7151-7157.

Yi, C., Shi, J. X., Xue, S. J., Jiang, Y. and Li, D. 2009. Effects of supercritical fluid extraction parameters on lycopene yield and antioxidant activity. *Food Chemistry* 113(4): 1088-1094.