



# Pre-launch Transfer to Orbit Testing for the Operational Land Imager 2 (OLI-2)

**Jordan Marks, Geir Kvaran,  
Nathan Leisso  
*Ball Aerospace***



Imagery Credit: USGS/NASA Landsat

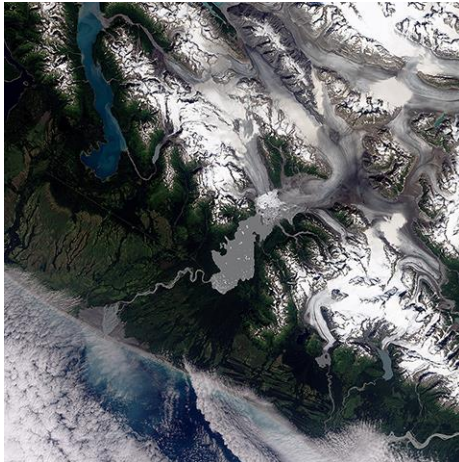
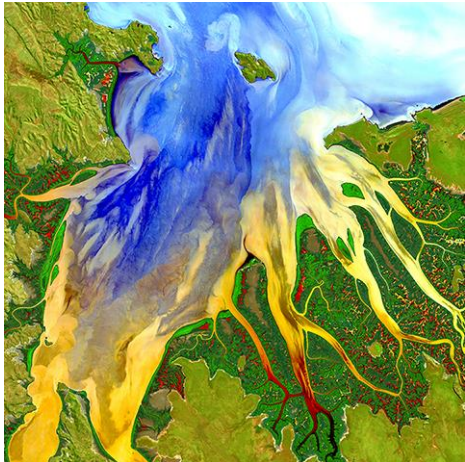



## Outline



- **Overview of stable on-board calibration sources (stim lamps and diffusers)**
  - Motivation for calibration source inclusion
  - Discussion of diffuser and stim lamp advantages and disadvantages as calibration sources
  
- **Transfer-to-orbit calibration methodology to assess stability of OLI-2 calibration sources between pre-launch and on-orbit environments**
  - Improved approach for transfer-to-orbit
  - Pre-launch Testing Results
    - Diffuser On-Orbit Predictions
    - Stim Lamp Bulb Temperatures



# OLI-2 includes calibration sources to allow assessment of instrument stability between pre-launch and on-orbit



## Diffusers

## Stim Lamps

- Two panels of space-grade Spectralon™
  - Act as near-Lambertian scatterers for incoming sunlight
  - One measured frequently, the other kept pristine
- Pre-launch, flight diffusers are illuminated using the heliostat
- Diffusers were characterized pre-launch at the University of Arizona, NIST Traceable

- Three pairs of lamps are mounted in two assemblies on either side of the OLI-2 aperture
- Lamps are used frequently pre-launch to track performance, then used daily on-orbit as a secondary standard

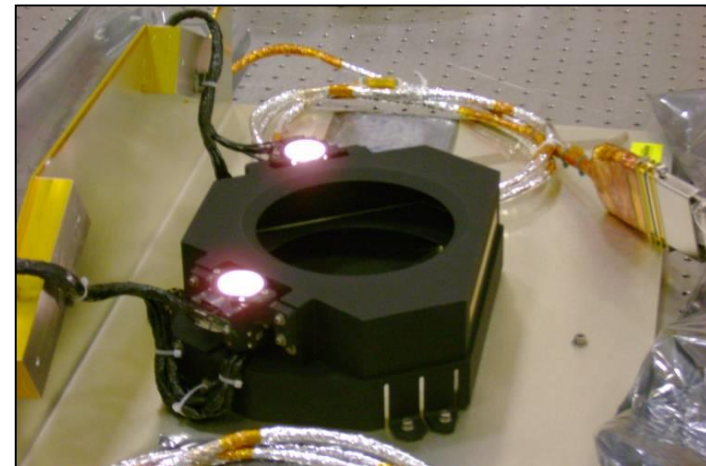
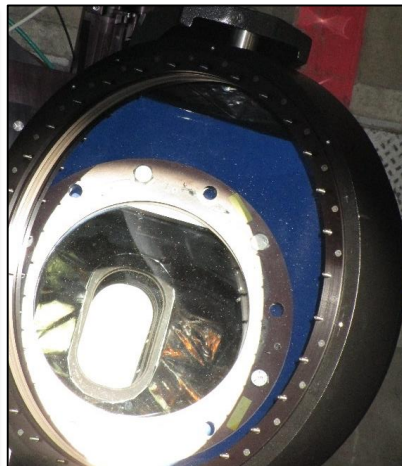
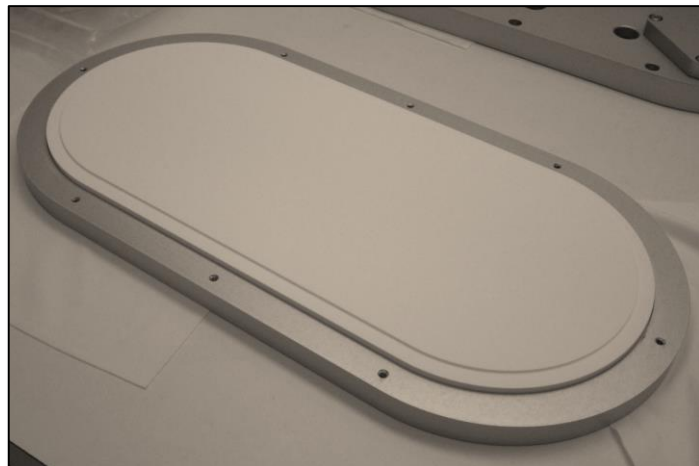



# Diffuser Advantages and Disadvantages



- The diffuser acts as a stable transfer to orbit source for all non-Cirrus bands (VIS/SWIR bands)
- Pre-launch measurements are directly comparable to on-orbit measurements
  - BRDF remains constant with attention to cleanliness
  - Infrequent use on-orbit minimizes degradation and maintains cleanliness
- Diffuser observation replicates OLI-2 earth-viewing observation
  - End-to-end illumination
  - Full field of view
  - Full aperture, equivalent  $A\Omega$

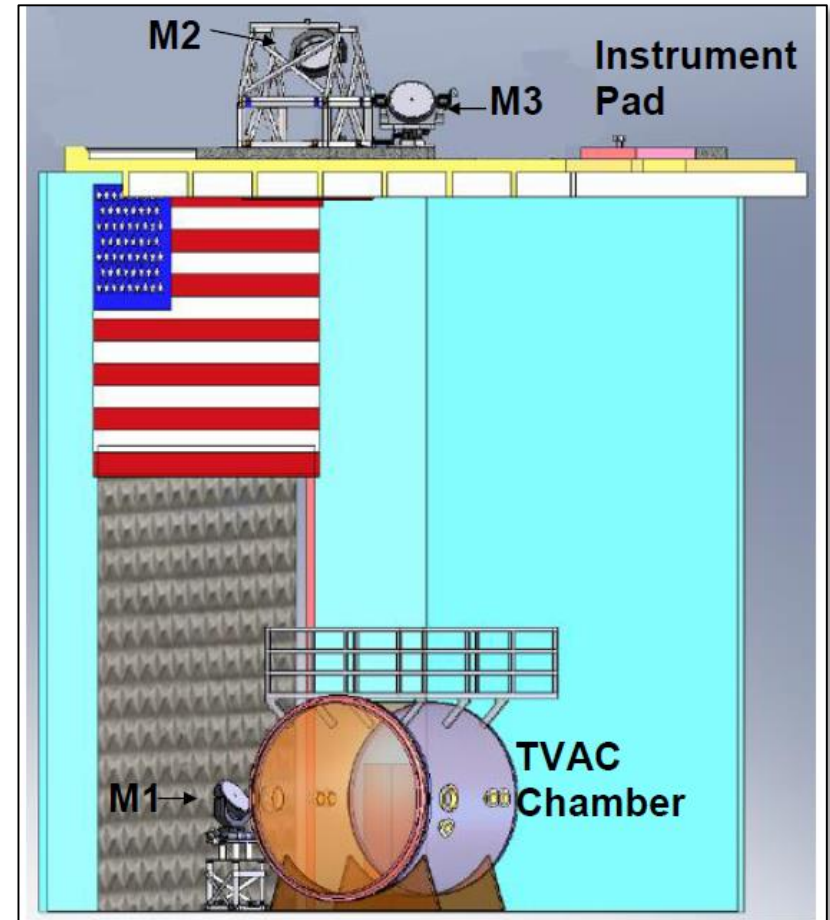



# Stim Lamp Advantages and Disadvantages



- Stim Lamps are required to validate Cirrus band calibration on-orbit.
- Stim lamp observation is similar to OLI-2 operation
  - End-to-end illumination
  - With both bulbs, full field of view
  - AΩ is similar but not identical
- Stim lamps images can be collected frequently
  - On orbit, collect daily stim lamp images
  - Lamps can be used anywhere in orbit for extended durations
- Stim lamps have predictable and repeatable patterns of illumination on the focal plane
  - Anticipate bulb color temperature change on-orbit due to vacuum, instrument orientation and 0G environment

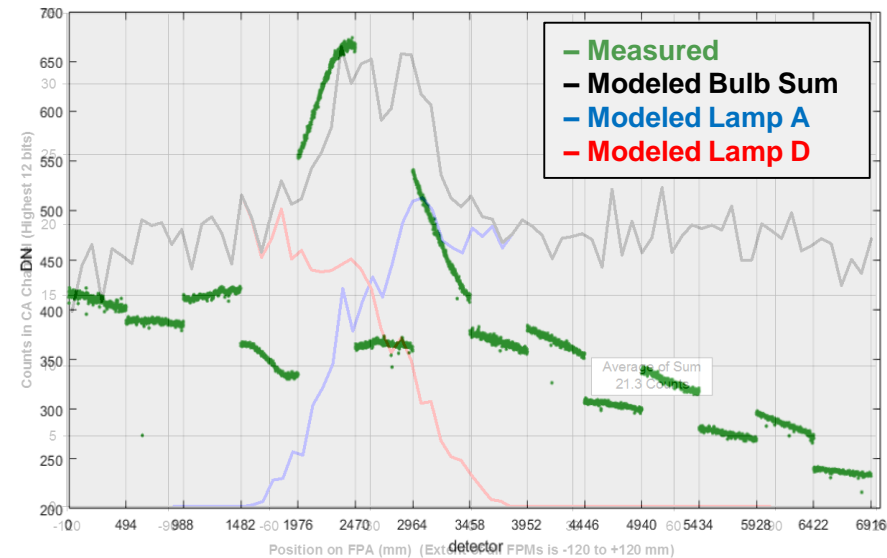
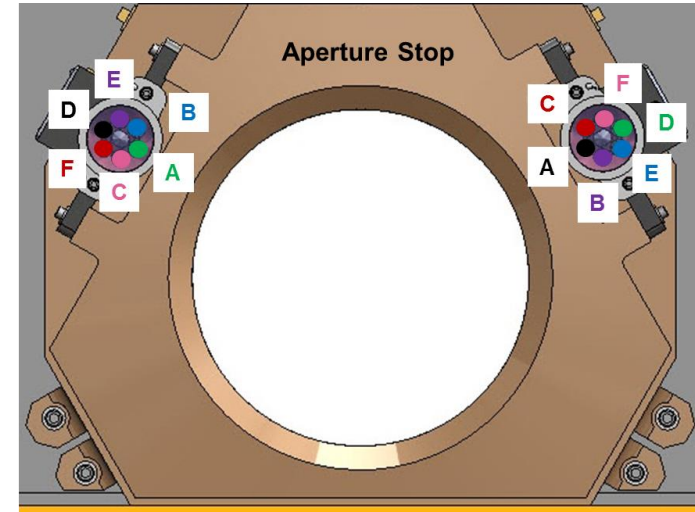



## Transfer to Orbit Methodology



- **Two calibration sources allow us to harness advantages of each and compare measurements**
  - Diffuser is closest to actual OLI-2  $A\Omega$ , and BRDF should not change on orbit
  - Stim lamps are highly repeatable, have a simple spectral shape, and offer greater operational freedom
  - Use of both sources allows comparison across time scales
  
- **Original transfer-to-orbit method replicated OLI method**
  - Use diffuser to calibrate Bands 1 – 8; update calibration coefficients as needed
  - Use cal coefficients & stim lamp images to calibrate Band 9
  
- **OLI-2 approach expands on the OLI approach and may offer improved calibration**
  - Use the diffuser to calibrate a subset of Bands 1 – 8; update calibration coefficients as needed
  - Use cal coefficients & stim lamp images to calibrate remaining bands



# Transfer to Orbit Methodology

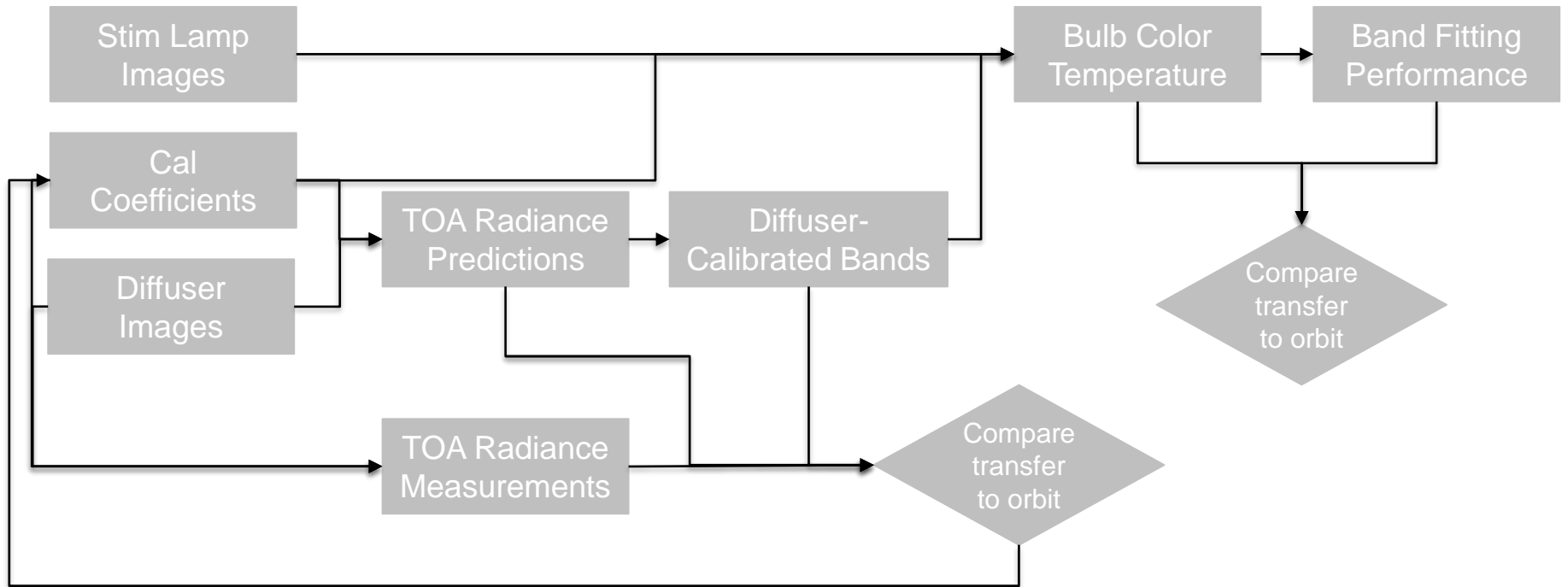

Measured on ground

Calculated with ground-based data

Measured on-orbit

Calculated with on-orbit data



# Transfer to Orbit Methodology

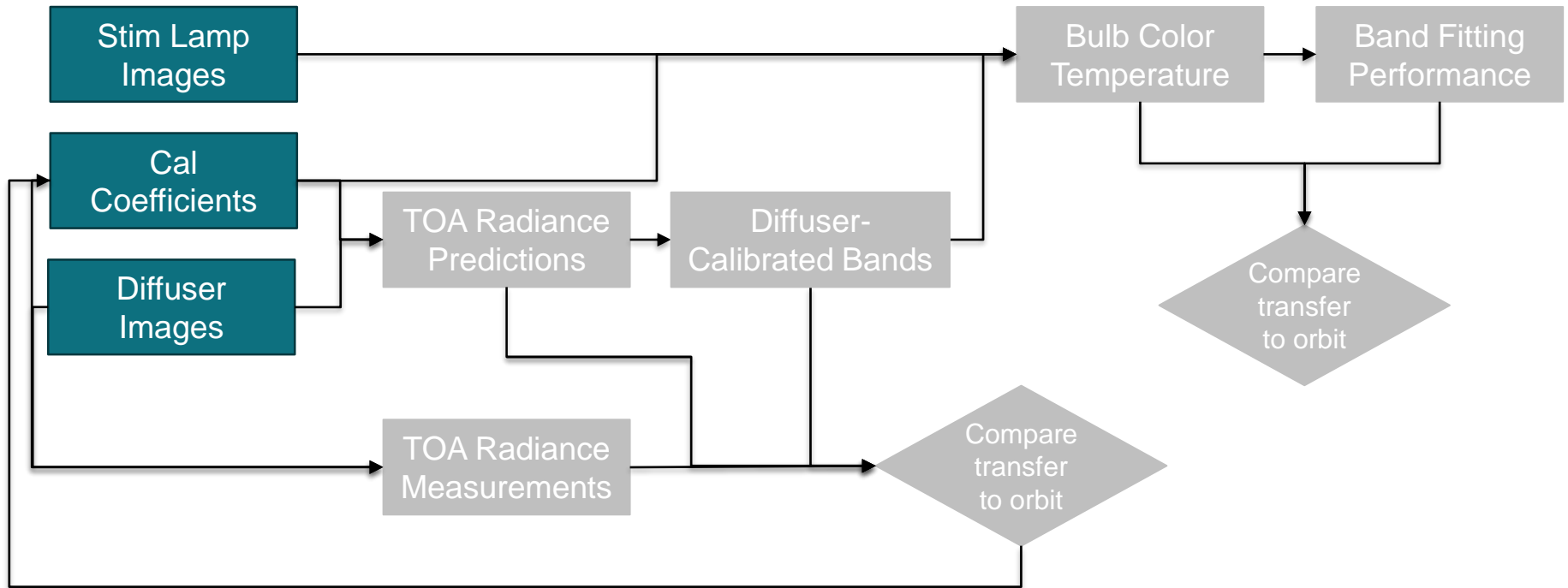

Calibration Alignment Test Station (CATS) measurements provided an integrated instrument-level observation of both calibration devices. Preliminary calibration coefficients have been calculated based on CATS data.

Measured on ground

Calculated with ground-based data

Measured on-orbit

Calculated with on-orbit data





# Transfer to Orbit Methodology

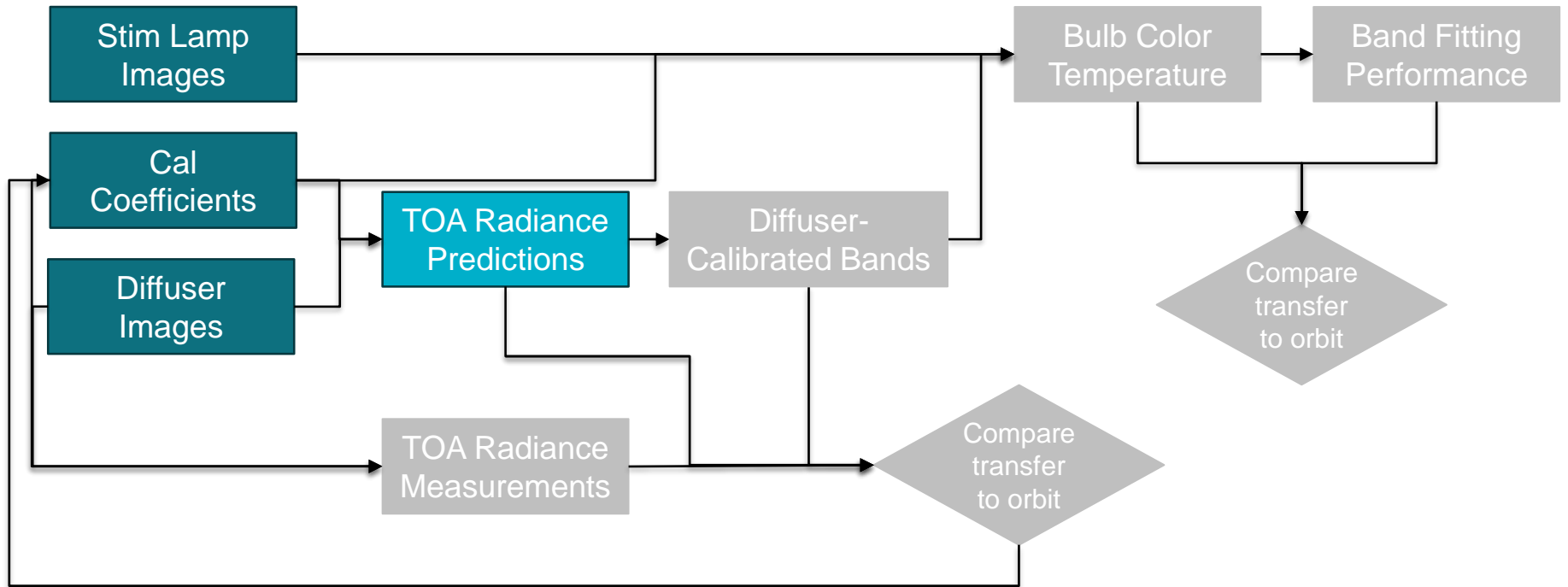

The diffuser and calibration coefficients, as well as CATS heliostat and atmospheric characterization data, are used to compute top of atmosphere (TOA) radiance predictions.

Measured on ground

Calculated with ground-based data

Measured on-orbit

Calculated with on-orbit data



# Transfer to Orbit Methodology

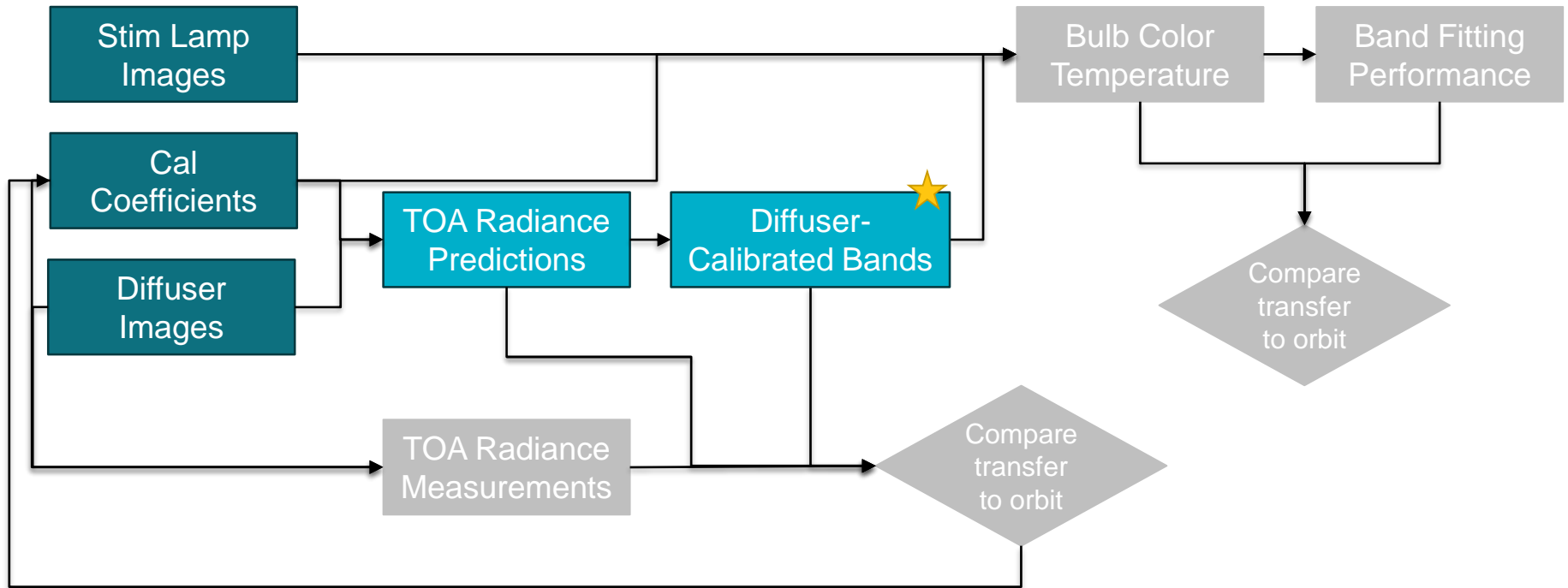

Original transfer-to-orbit method uses the diffuser for all VIS/SWIR bands. OLI-2 approach determines a subset of bands to be calibrated using the diffuser based on the radiance predictions.

Measured on ground

Calculated with ground-based data

Measured on-orbit

Calculated with on-orbit data



# Transfer to Orbit Methodology

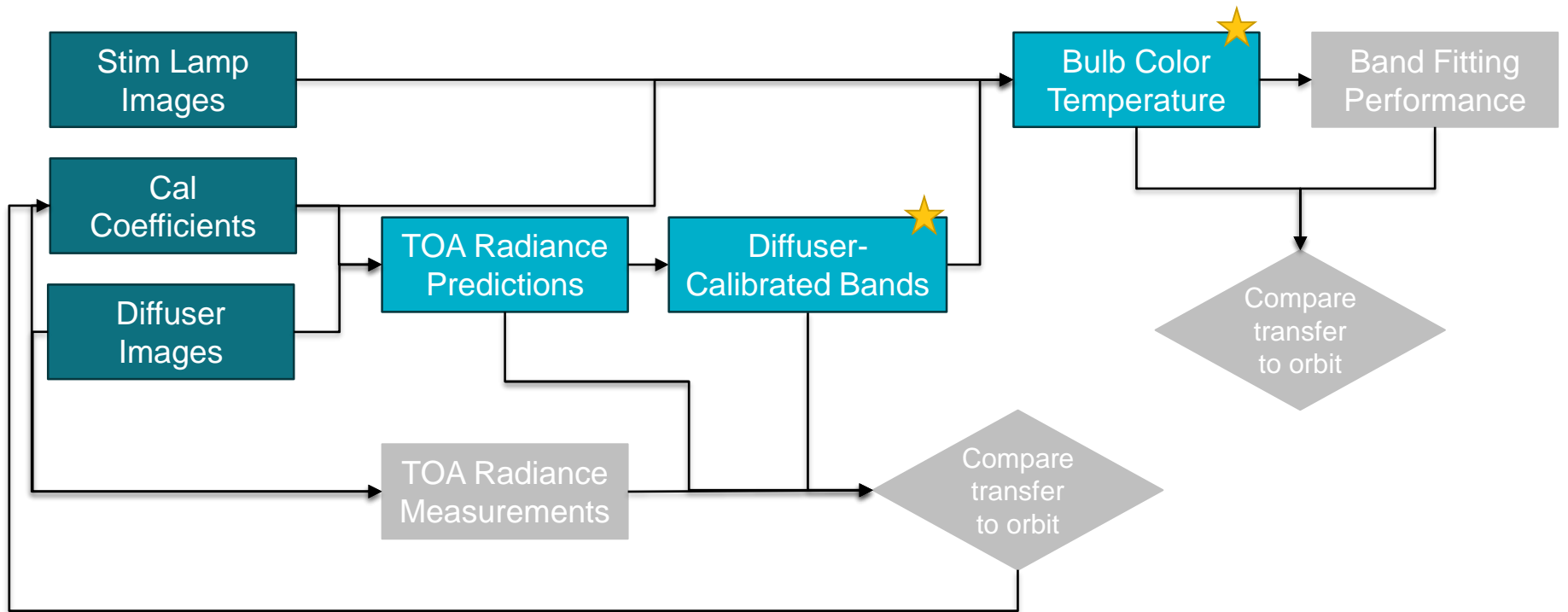

Stim lamp radiances are calculated. Radiance from each diffuser-calibrated bands is used to calculate a color temperature for each bulb.

Measured on ground

Calculated with ground-based data

Measured on-orbit

Calculated with on-orbit data



# Transfer to Orbit Methodology

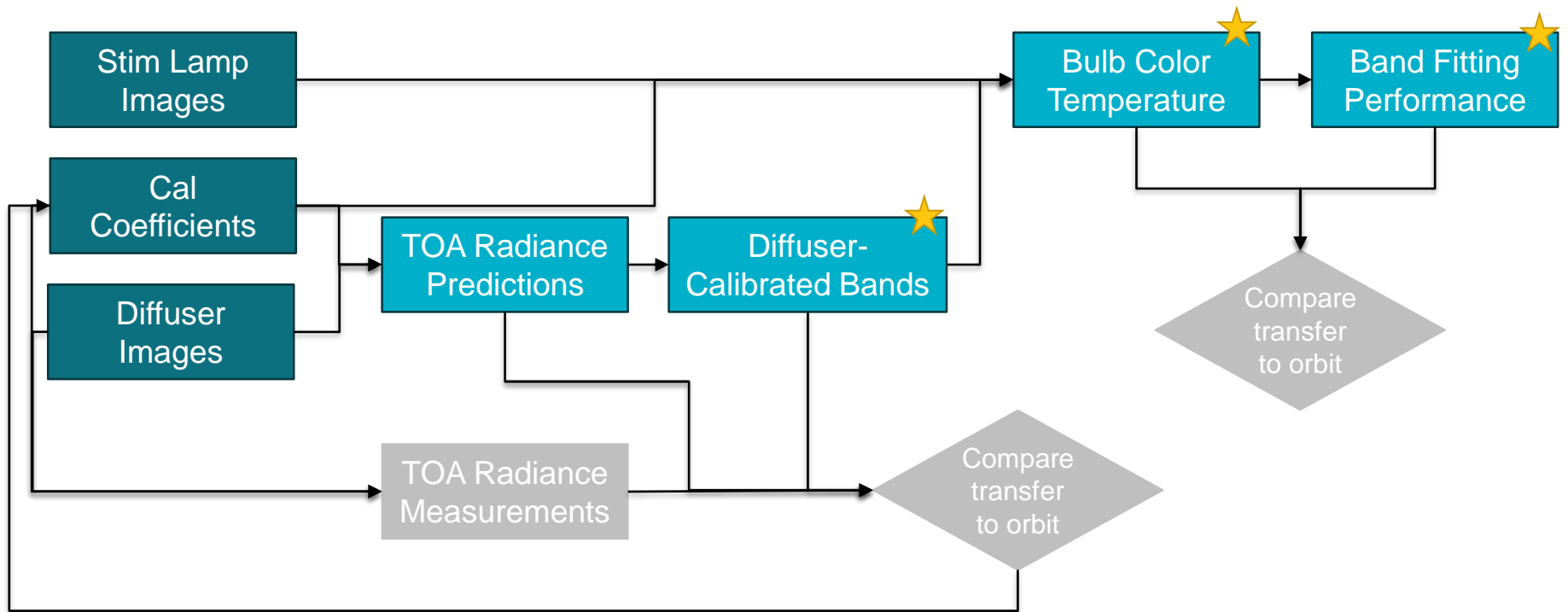

The error between the temperature fitting curve and radiance in each band is calculated. This error (the **Stim Lamp Fit Metric**) should be stable between ground measurements and orbit.

Measured on ground

Calculated with ground-based data

Measured on-orbit

Calculated with on-orbit data



# Transfer to Orbit Methodology

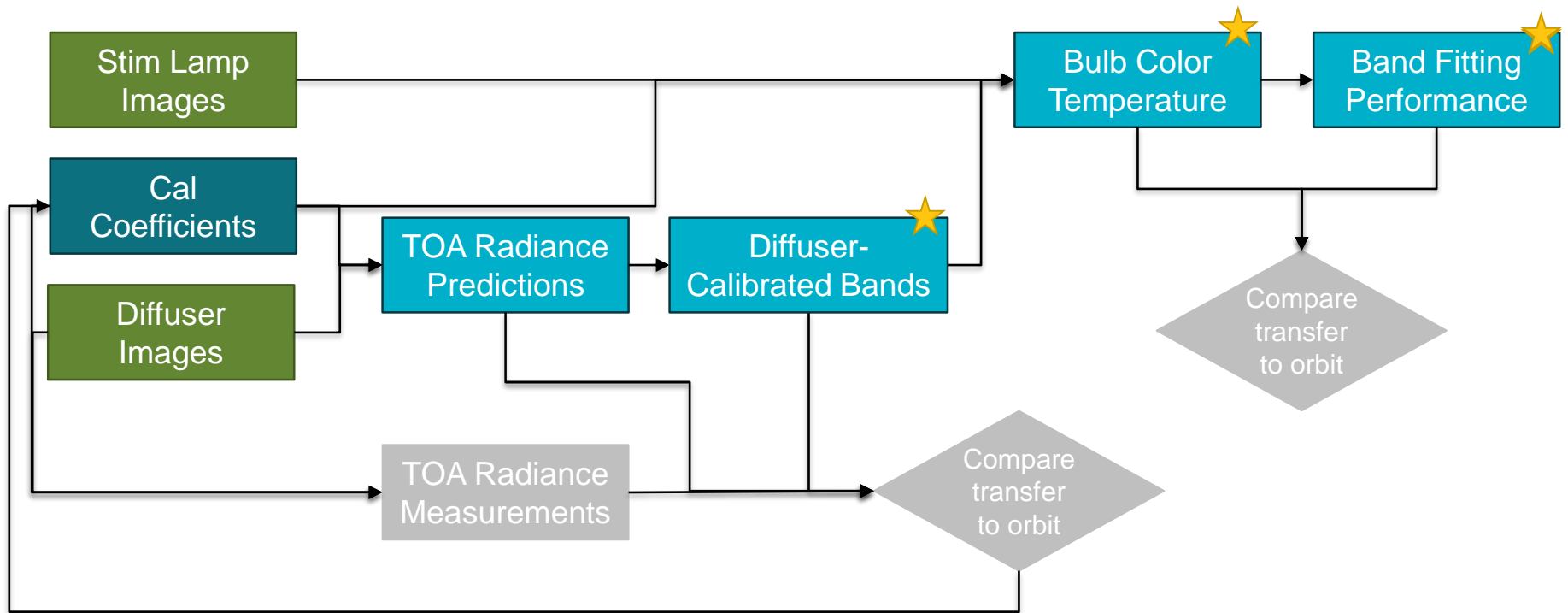

On orbit, stim lamp and diffuser images are collected.

Measured on ground

Calculated with ground-based data

Measured on-orbit

Calculated with on-orbit data



# Transfer to Orbit Methodology

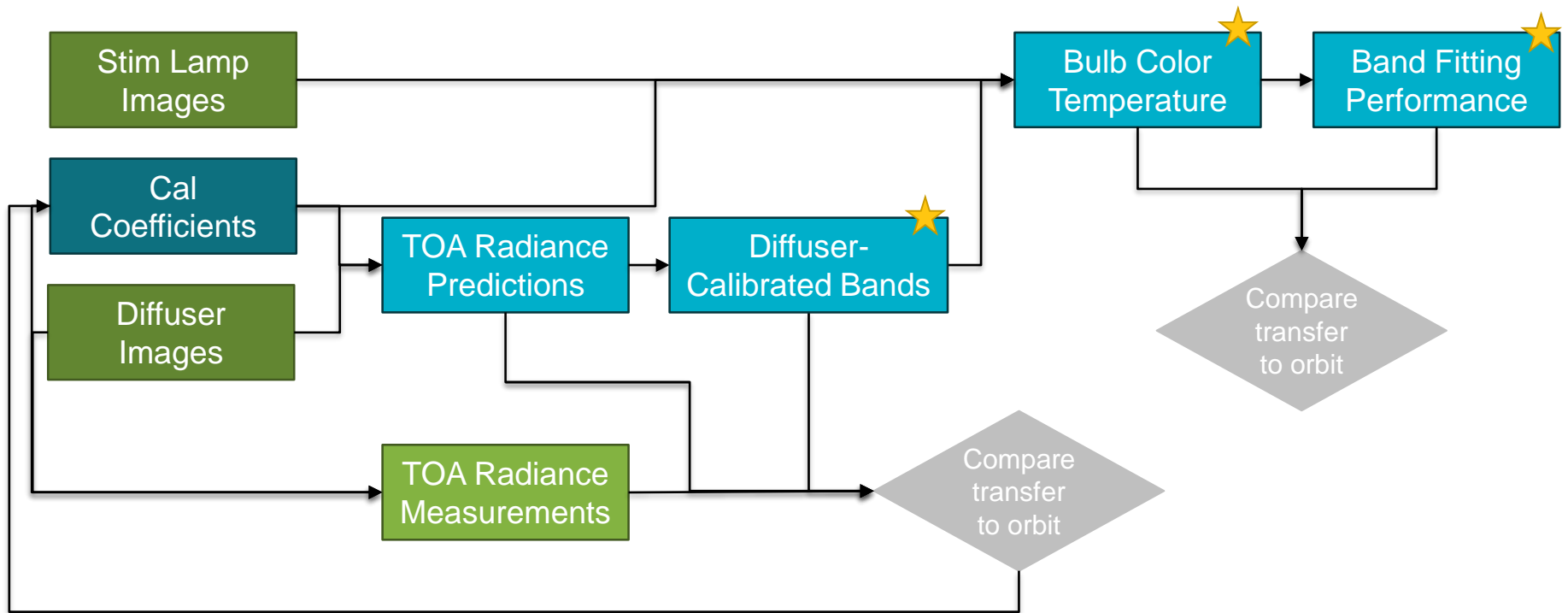

The ground-based calibration coefficients and the on-orbit diffuser images are used to measure the TOA radiance.

Measured on ground

Calculated with ground-based data

Measured on-orbit

Calculated with on-orbit data



# Transfer to Orbit Methodology

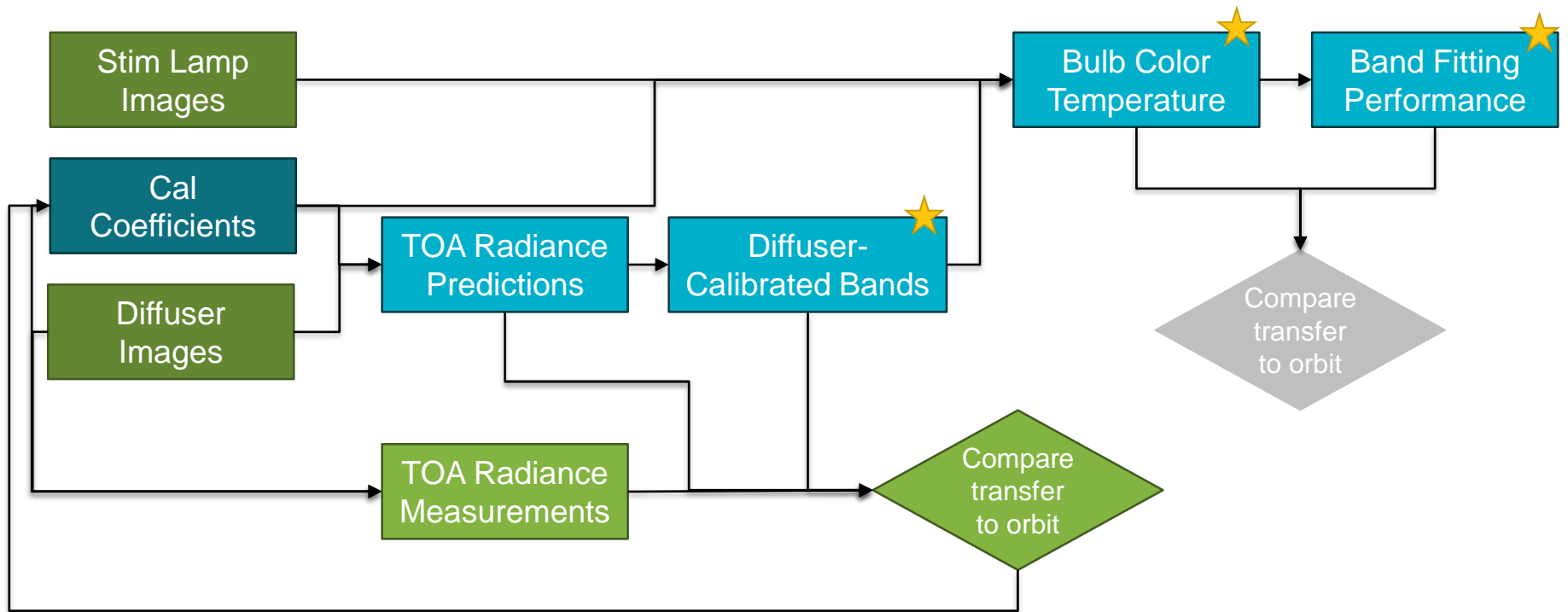

The TOA radiance measurements are compared to the TOA predictions for the diffuser-calibrated bands.

Measured on ground

Calculated with ground-based data

Measured on-orbit

Calculated with on-orbit data



# Transfer to Orbit Methodology

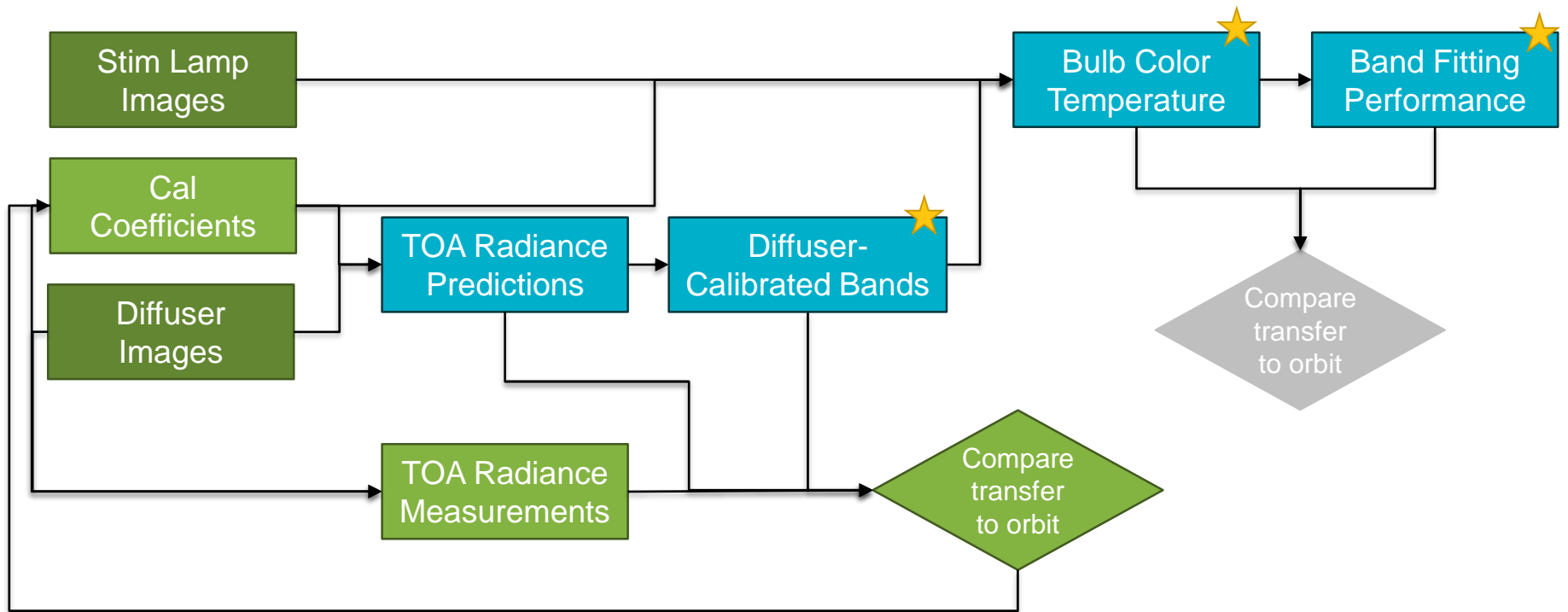

If necessary, the calibration coefficients are updated for the diffuser-calibrated bands.

Measured on ground

Calculated with ground-based data

Measured on-orbit

Calculated with on-orbit data





# Transfer to Orbit Methodology

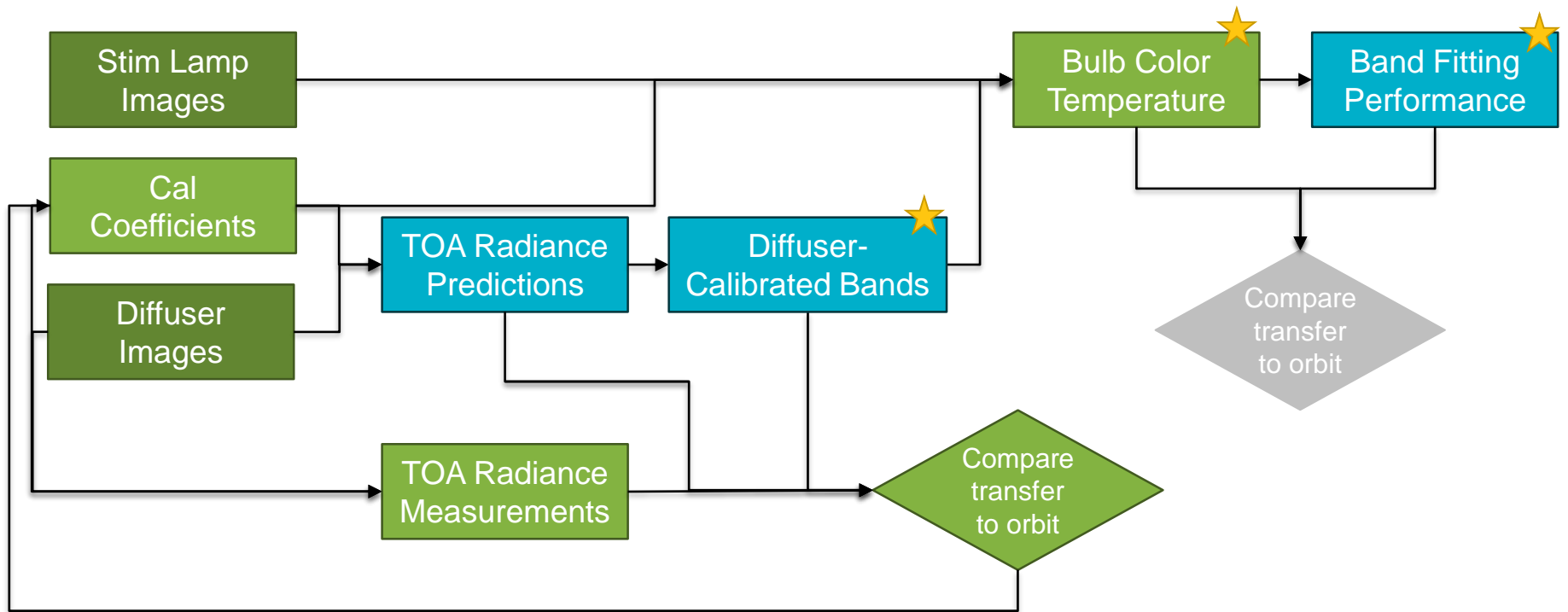

Updated calibration coefficients and on-orbit stim lamp data are used to calculate stim lamp radiance, and the bulb color temperatures using the diffuser-calibrated bands.

Measured on ground

Calculated with ground-based data

Measured on-orbit

Calculated with on-orbit data



# Transfer to Orbit Methodology

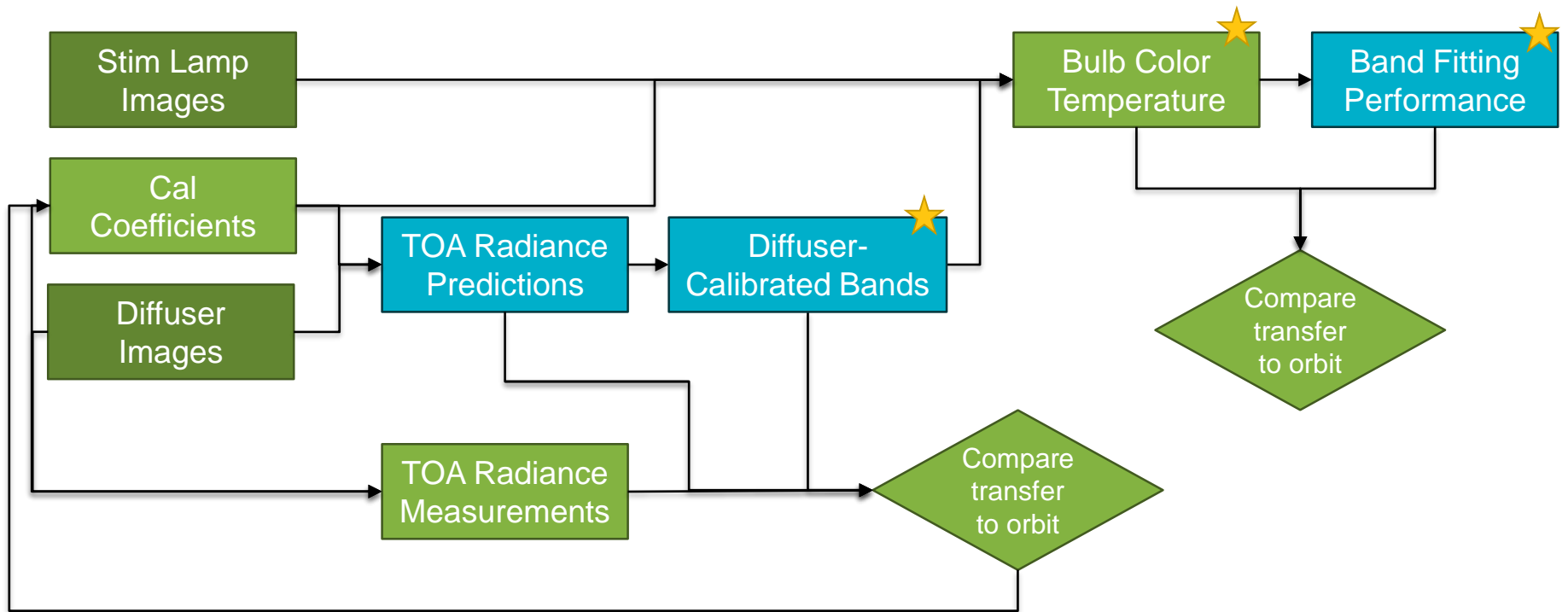

The **Stim Lamp Fit Metric** will be used to re-calibrate remaining bands.

Measured on ground

Calculated with ground-based data

Measured on-orbit

Calculated with on-orbit data



# Two methods to predict diffuser top of atmosphere spectral radiance



- **Method 1: Spectral Irradiance from Literature**

$$L_{bw,b,d}(t) = \frac{\int_0^{\infty} E_{\lambda,sun}(\lambda) * BRDF_b * NU_{b,d}(t_{CATS}) * R_b(\lambda) * \cos(\theta) d\lambda}{D^2(t) \int_0^{\infty} R_b(\lambda) d\lambda}$$

- **Method 2: Measured Solar Diffuser Radiance from Heliostat Experiment**

$$L_{bw,b,d}(t) = \frac{L_{bw,b,d}(t_{CATS})}{\tau_{helio,b} \tau_{atm,b}} \frac{D^2(t_{CATS})}{D^2(t)}$$



# Method 1: Irradiance-Based Calculation



Solar spectral  
irradiances from  
literature  
( $W m^{-2} \mu m^{-1}$ )

BRDF  
( $sr^{-1}$ )

Non-Uniformity  
(#)

Measured RSR  
(#)

Incidence angle  
on diffuser  
(rad)

$$L_{bw,b,d}(t) = \frac{\int_0^{\infty} E_{\lambda,sun}(\lambda) * BRDF_b * NU_{b,d}(t_{CATS}) * R_b(\lambda) * \cos(\theta) d\lambda}{D^2(t) \int_0^{\infty} R_b(\lambda) d\lambda}$$

Band-weighted  
spectral radiance  
( $W m^{-2} \mu m^{-1} sr^{-1}$ )

Earth-Sun Distance  
(#)



# Method 1: Irradiance-Based Calculation



Solar Irradiance

$$L_{bw,b,d}(t) = \frac{\int_0^{\infty} E_{\lambda,sun}(\lambda) * BRDF_b * NU_{b,d}(t_{CATS}) * R_b(\lambda) * \cos(\theta) d\lambda}{D^2(t) \int_0^{\infty} R_b(\lambda) d\lambda}$$

- Examining three solar irradiance spectra

- CHKUR
- CEOS
- Thuillier 2002 (used on OLI)

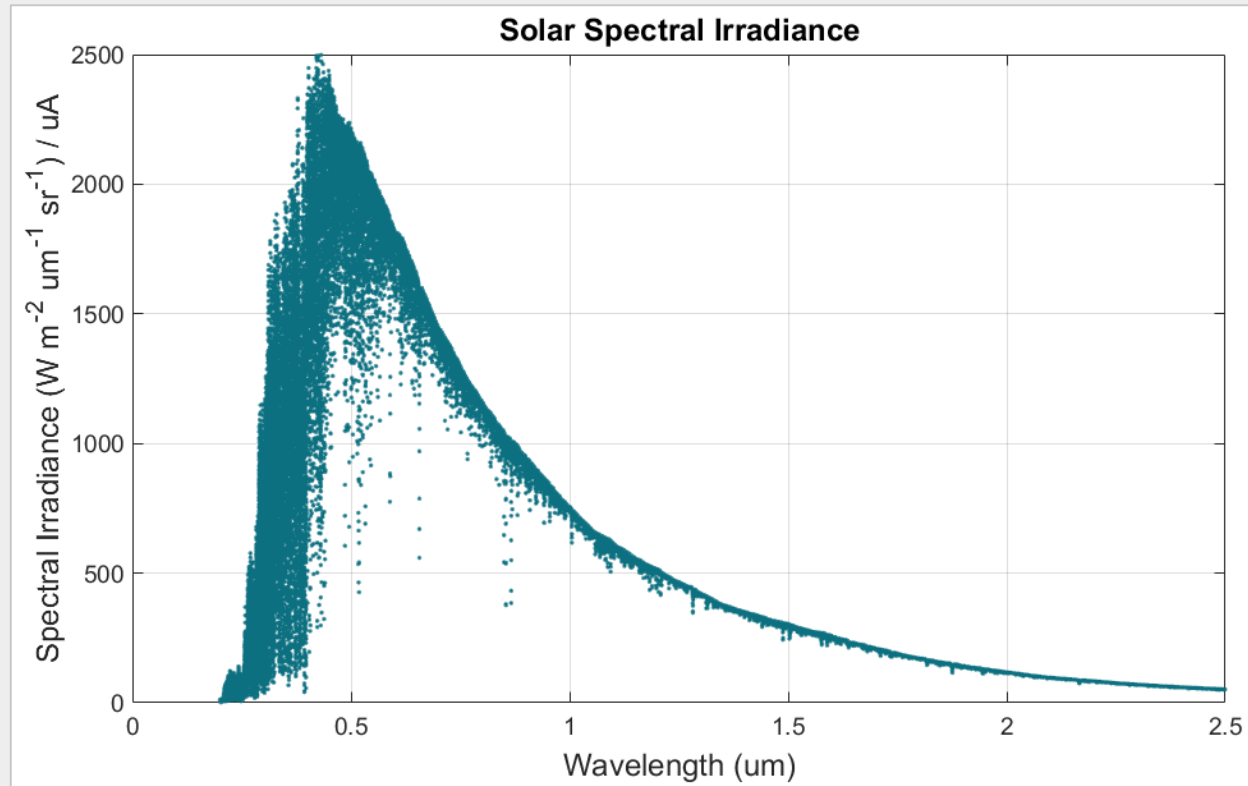



# Method 1: Irradiance-Based Calculation



$$L_{bw,b,d}(t) = \frac{\int_0^\infty E_{\lambda,sun}(\lambda) * \overset{BRDF}{BRDF_b} * NU_{b,d}(t_{CATS}) * R_b(\lambda) * \cos(\theta) d\lambda}{D^2(t) \int_0^\infty R_b(\lambda) d\lambda}$$

- Witness Samples were cut from the same block of material as the flight diffusers; used to monitor contamination
- Diffuse reflectance standard panels in test were calibrated at NIST
- University of Arizona measured multiple panel locations at various wavelengths

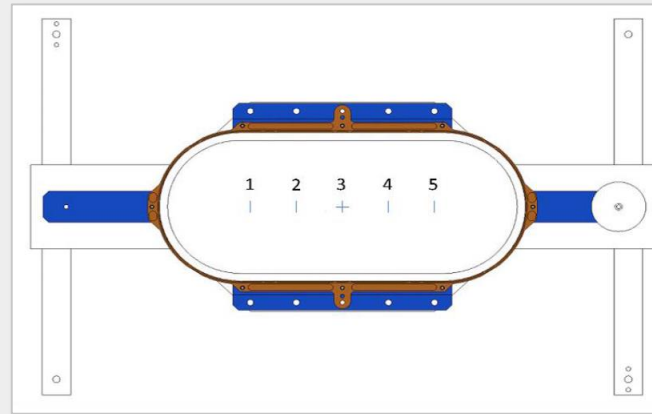

*Diffuser test locations*

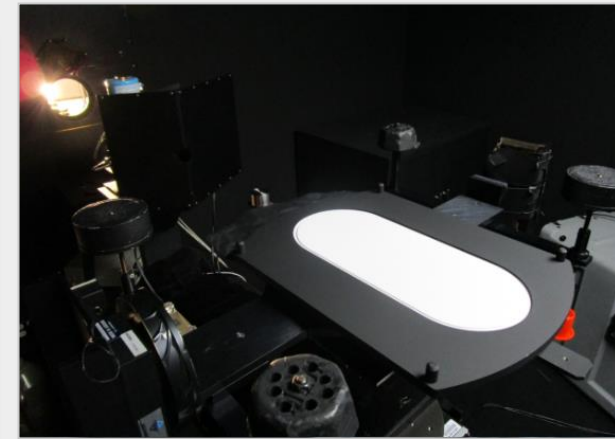

*Flight diffuser BRDF testing at the University of Arizona*



# Method 1: Irradiance-Based Calculation



Non-uniformity

$$L_{bw,b,d}(t) = \frac{\int_0^\infty E_{\lambda,sun}(\lambda) * BRDF_b * NU_{b,d}(t_{CATS}) * R_b(\lambda) * \cos(\theta) d\lambda}{D^2(t) \int_0^\infty R_b(\lambda) d\lambda}$$

- Non-uniformity is a result of illumination angle
- See ~5% change in radiance across full field of view (FFOV)

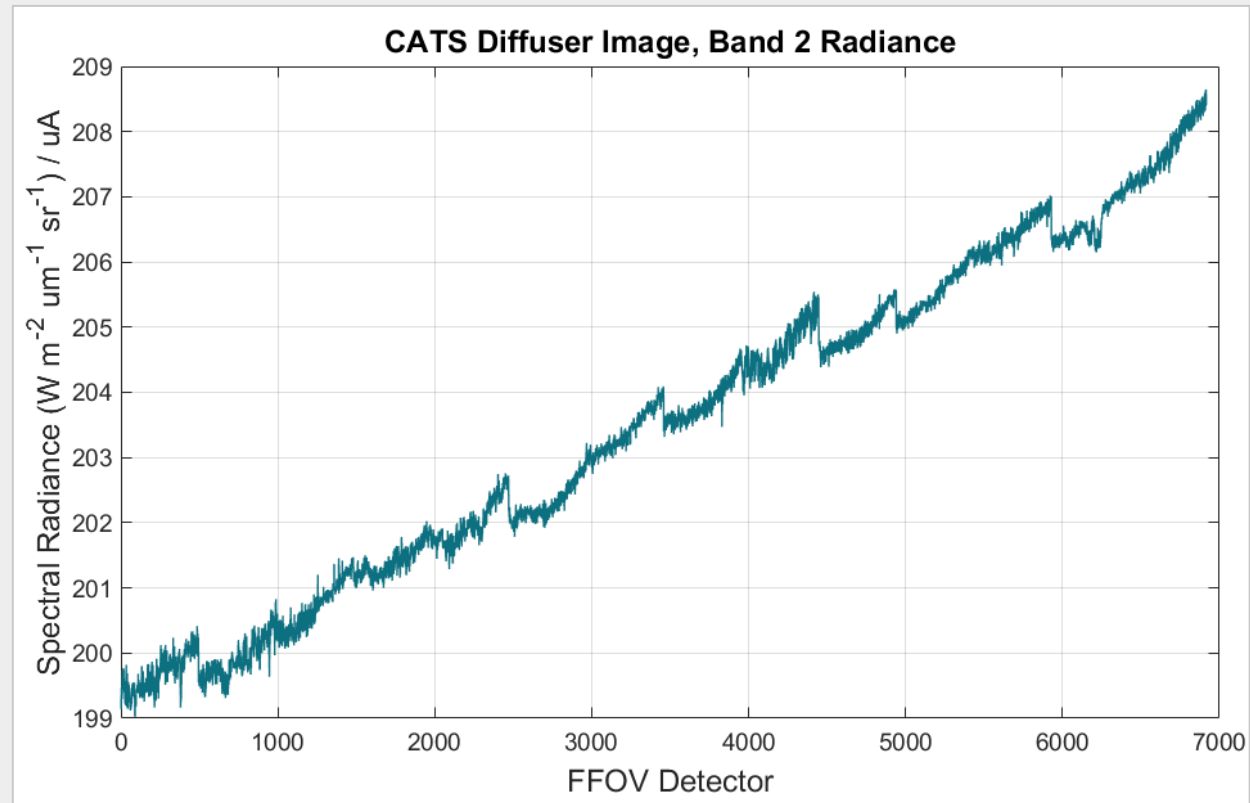



# Method 1: Irradiance-Based Calculation



Measured RSR

$$L_{bw,b,d}(t) = \frac{\int_0^{\infty} E_{\lambda,sun}(\lambda) * BRDF_b * NU_{b,d}(t_{CATS}) * R_b(\lambda) * \cos(\theta) d\lambda}{D^2(t) \int_0^{\infty} R_b(\lambda) d\lambda}$$

- Measured during CATS spectral testing
- This is averaged over all detectors and focal plane modules (FPMs) within each band

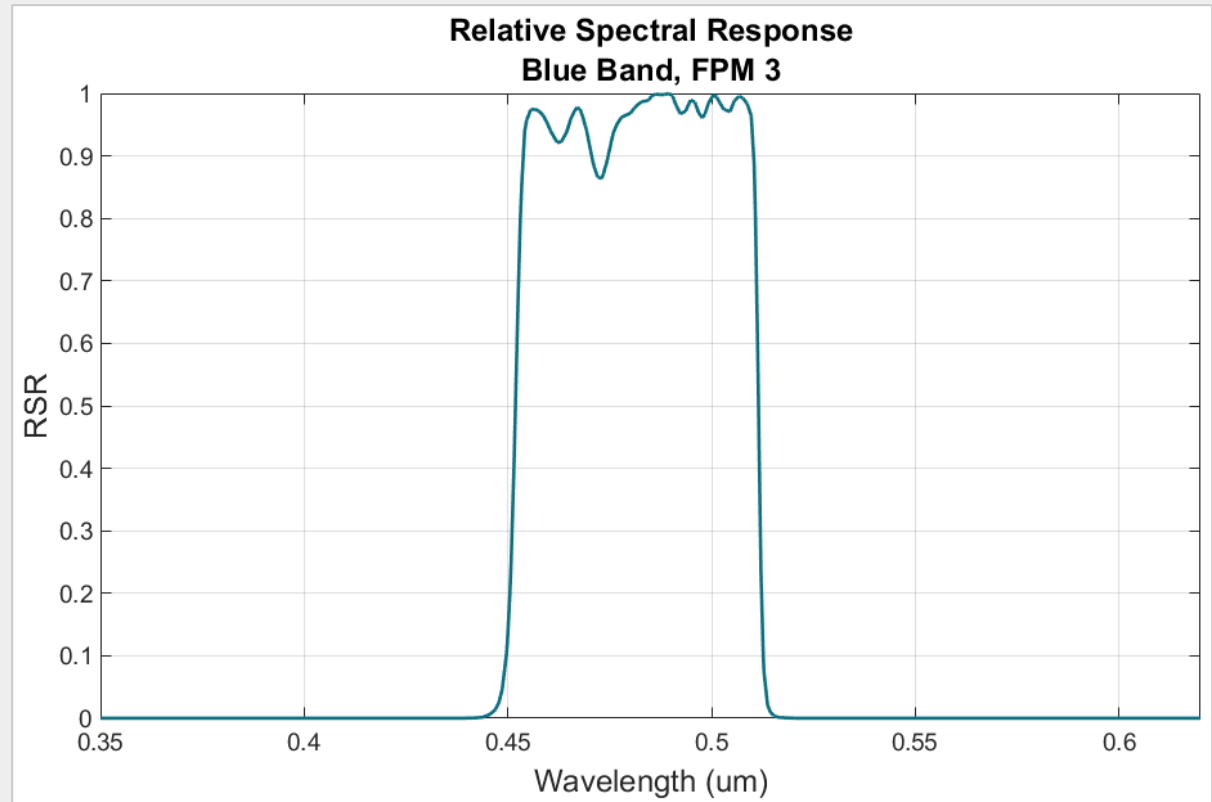





# Method 1: Irradiance-Based Calculation



$$L_{bw,b,d}(t) = \frac{\int_0^{\infty} E_{\lambda,sun}(\lambda) * BRDF_b * NU_{b,d}(t_{CATS}) * R_b(\lambda) * \cos(\theta) d\lambda}{D^2(t) \int_0^{\infty} R_b(\lambda) d\lambda}$$

*Incidence Angle* ↘

- Light is incident on the diffuser at an angle of 45° by design of solar calibration subsystem

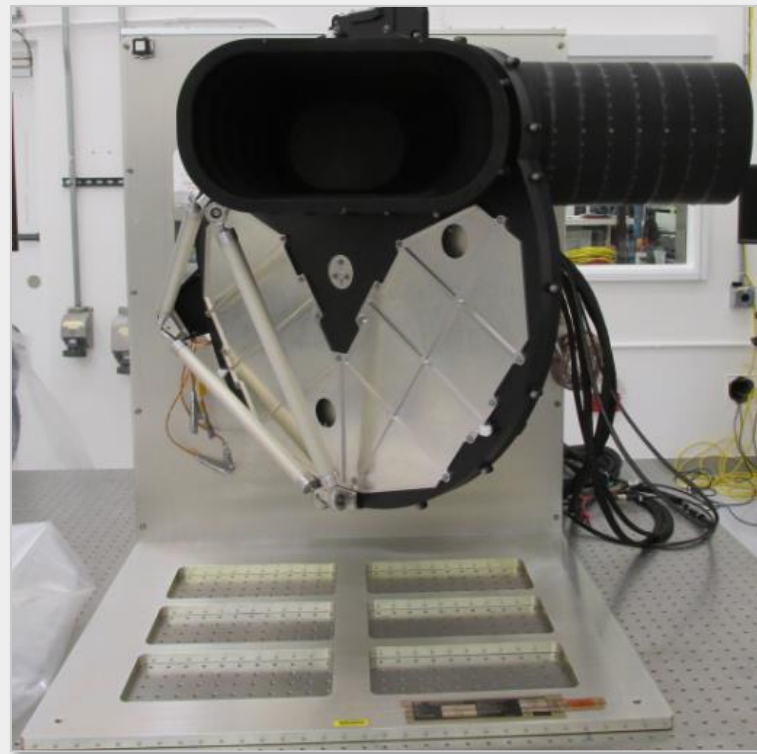



# Method 1: Irradiance-Based Calculation



$$L_{bw,b,d}(t) = \frac{\int_0^{\infty} E_{\lambda,sun}(\lambda) * BRDF_b * NU_{b,d}(t_{CATS}) * R_b(\lambda) * \cos(\theta) d\lambda}{D^2(t) \int_0^{\infty} R_b(\lambda) d\lambda}$$

Earth Sun Distance

- Day of year is used to calculate earth-sun distance to correct solar irradiance

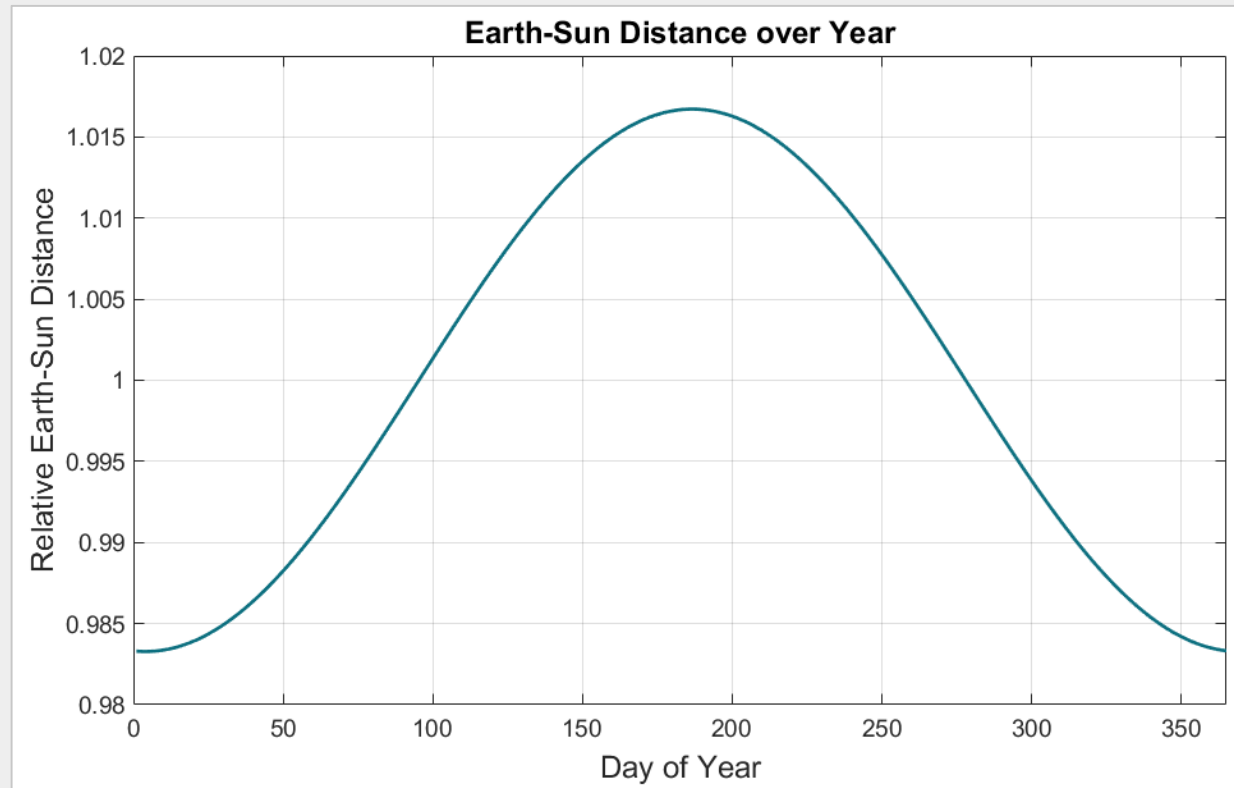



## Method 2: Radiance-Based Calculation

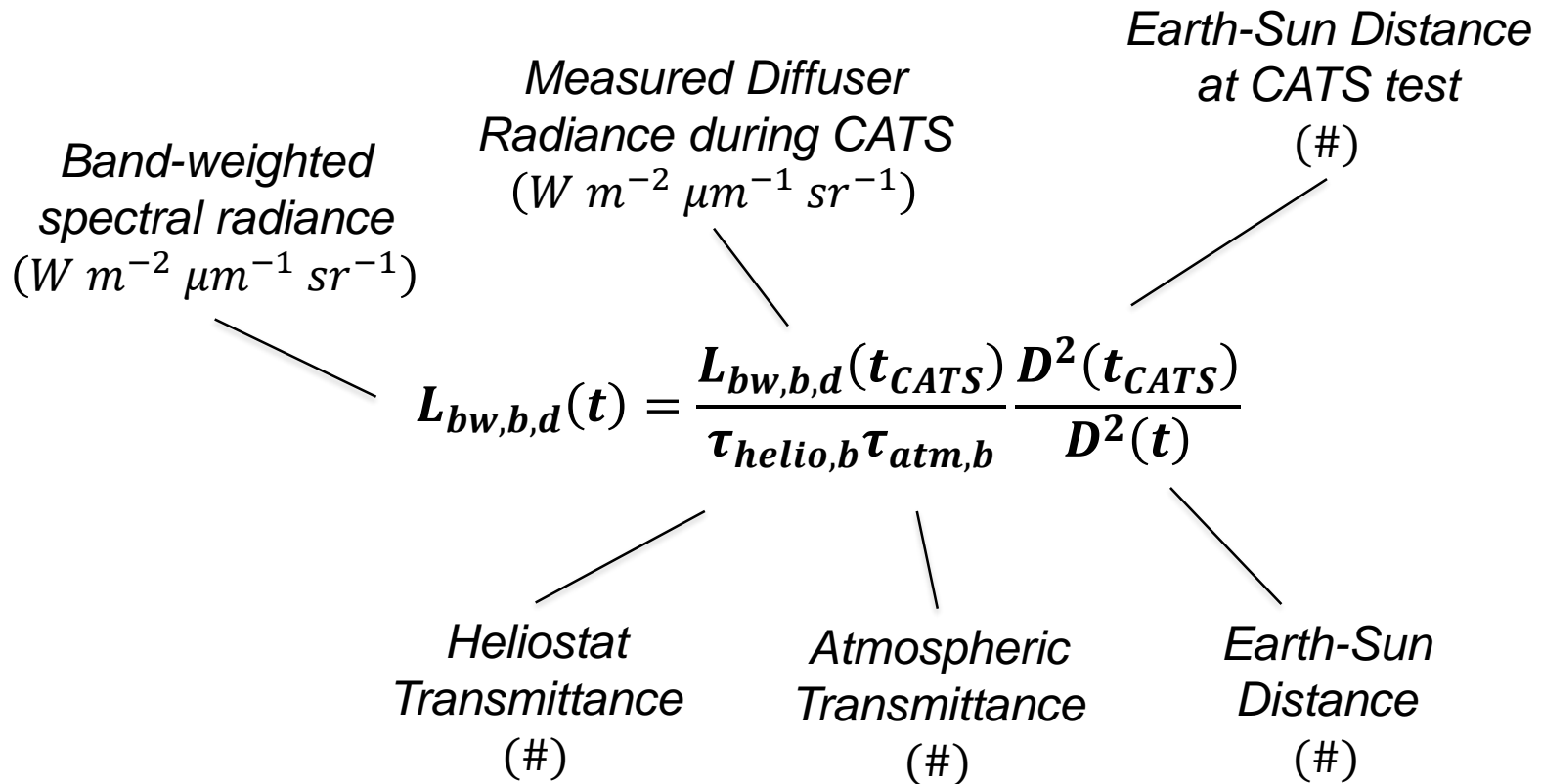



## Method 2: Radiance-Based Calculation



Measured Diffuser Radiance

$$L_{bw,b,d}(t) = \frac{L_{bw,b,d}(t_{CATS}) D^2(t_{CATS})}{\tau_{helio,b} \tau_{atm,b} D^2(t)}$$

- On-ground diffuser radiance is taken as the average of the two most spatially similar images

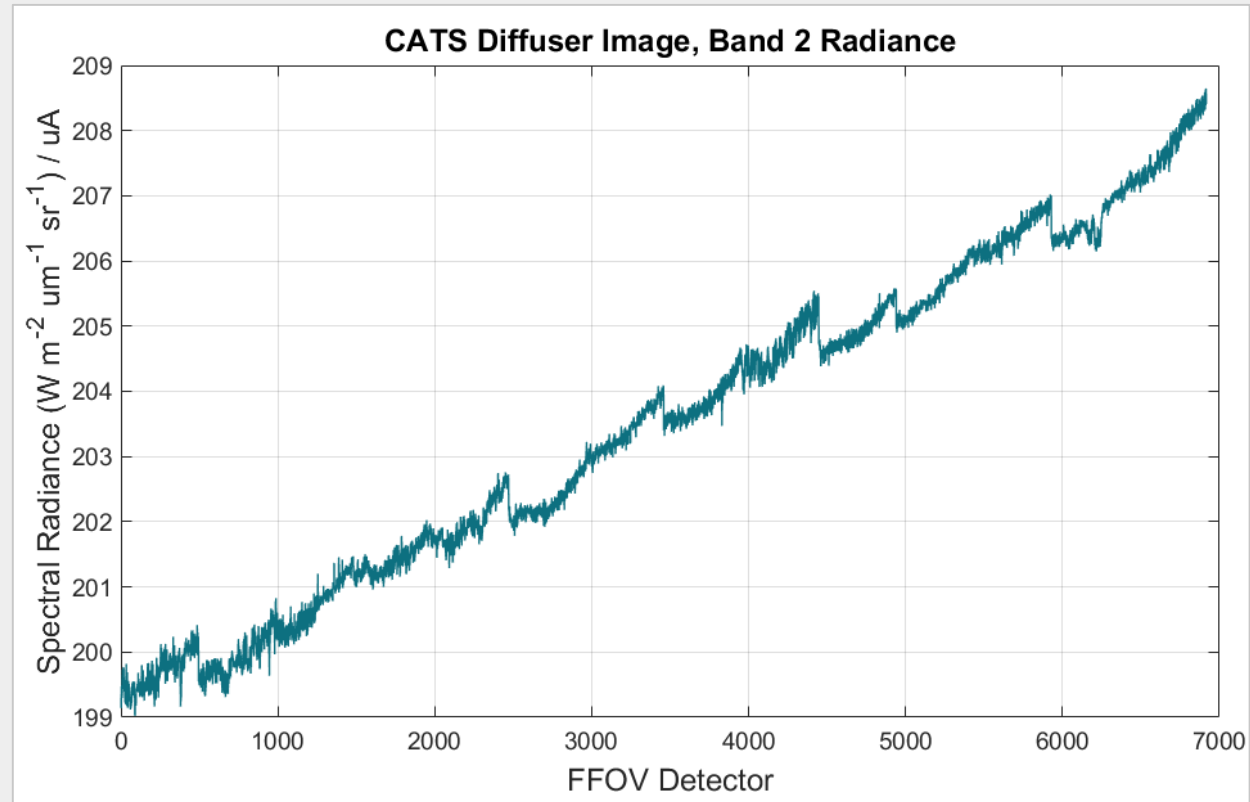



## Method 2: Radiance-Based Calculation



$$L_{bw,b,d}(t) = \frac{L_{bw,b,d}(t_{CATS}) D^2(t_{CATS})}{\tau_{helio,b} \tau_{atm,b} D^2(t)}$$

*Heliostat Transmittance* —

- Heliostat transmission was measured with two spectrometers mounted on the calibration panel
- Used Automated Solar Radiometer (ASR) during heliostat characterization to correct atmospheric transmittance changes
- Transmission calculation includes chamber window transmission measured with Cary spectrometer



*ASR was set up on test roof to get real-time atmospheric measurements*

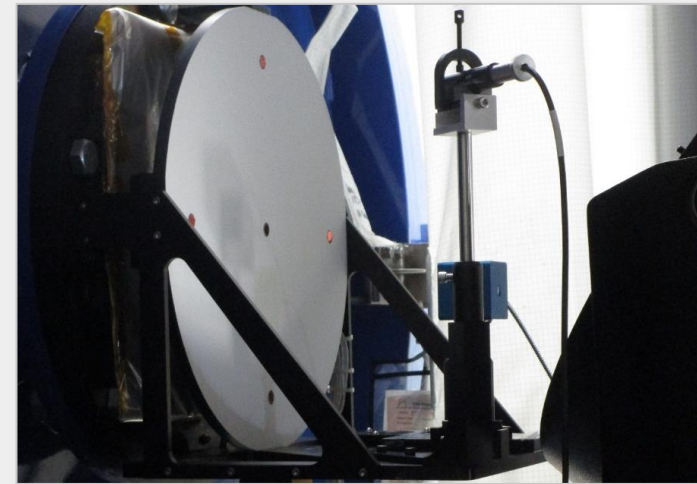

*Heliostat calibration panel, with U of A ASD attached*



## Method 2: Radiance-Based Calculation



$$L_{bw,b,d}(t) = \frac{L_{bw,b,d}(t_{CATS}) D^2(t_{CATS})}{\tau_{helio,b} \tau_{atm,b} D^2(t)}$$

*Heliostat Transmittance* —

- Heliostat transmission was measured with two spectrometers mounted on the calibration panel
- Used Automated Solar Radiometer (ASR) during heliostat characterization to correct atmospheric transmittance changes
- Transmission calculation includes chamber window transmission measured with Cary spectrometer

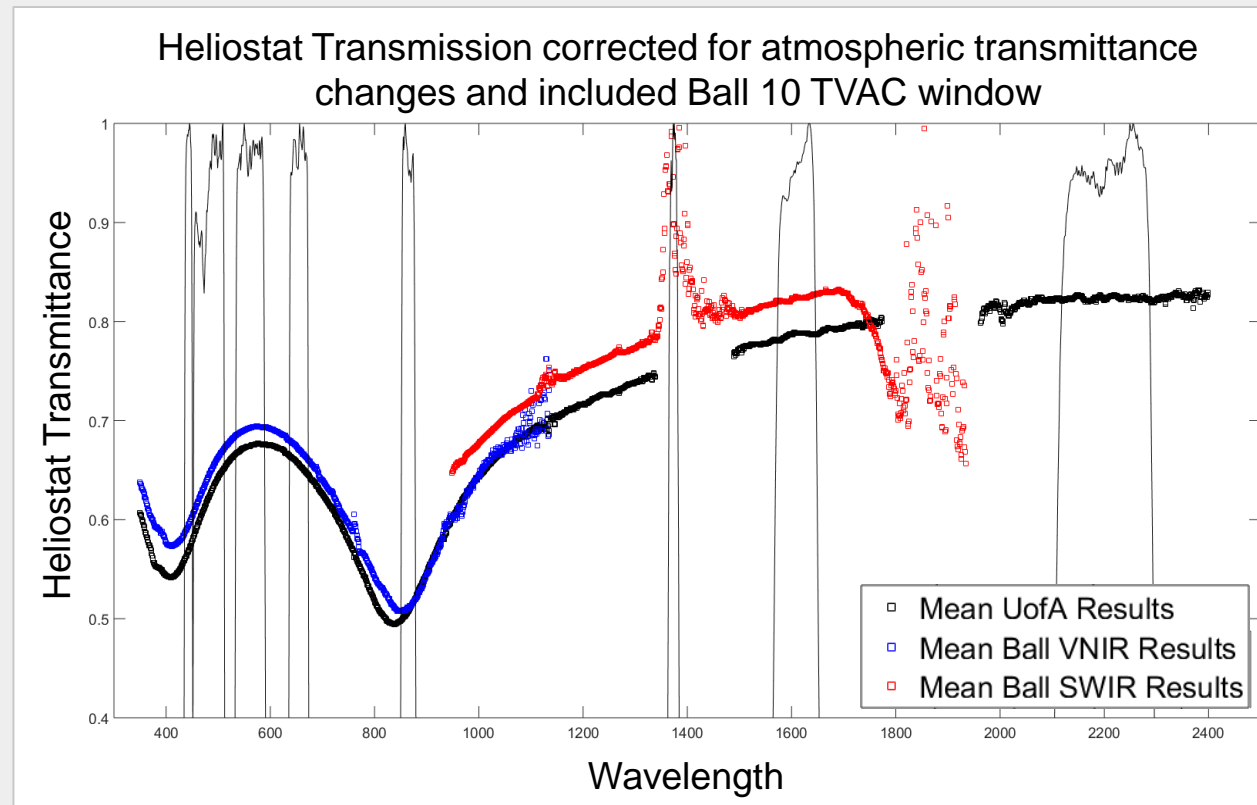



## Method 2: Radiance-Based Calculation



$$L_{bw,b,d}(t) = \frac{L_{bw,b,d}(t_{CATS}) D^2(t_{CATS})}{\tau_{helio,b} \tau_{atm,b} D^2(t)}$$

Atmospheric Transmittance

- ASR was collected during heliostat operation because solar transmittance changes based on pathlength and air column clarity

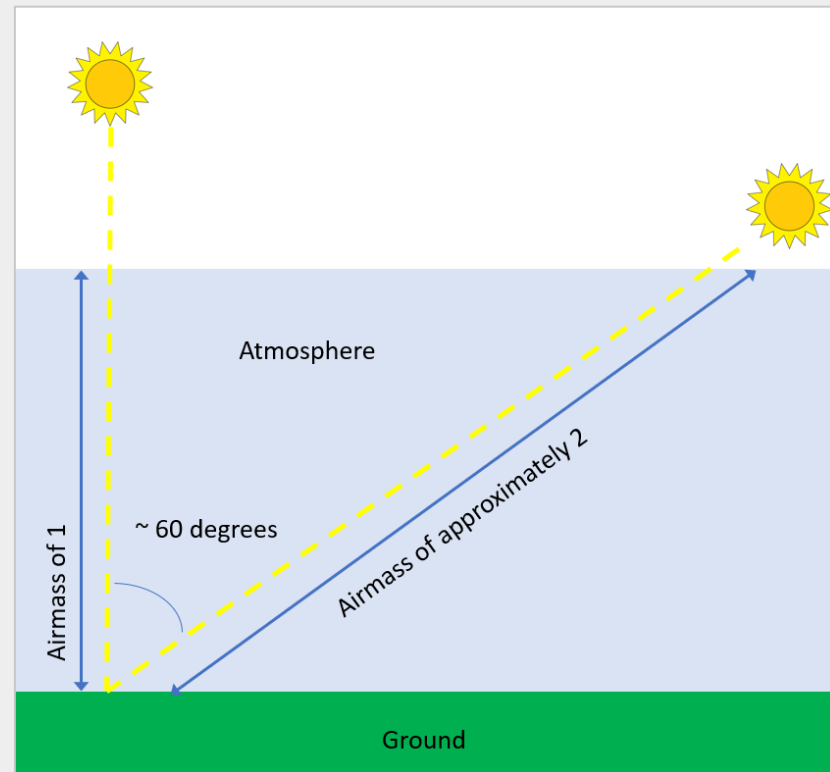



## Method 2: Radiance-Based Calculation



$$L_{bw,b,d}(t) = \frac{L_{bw,b,d}(t_{CATS}) D^2(t_{CATS})}{\tau_{helio,b} \tau_{atm,b} D^2(t)}$$

Atmospheric Transmittance

- ASR was collected during heliostat operation because solar transmittance changes based on pathlength and air column clarity

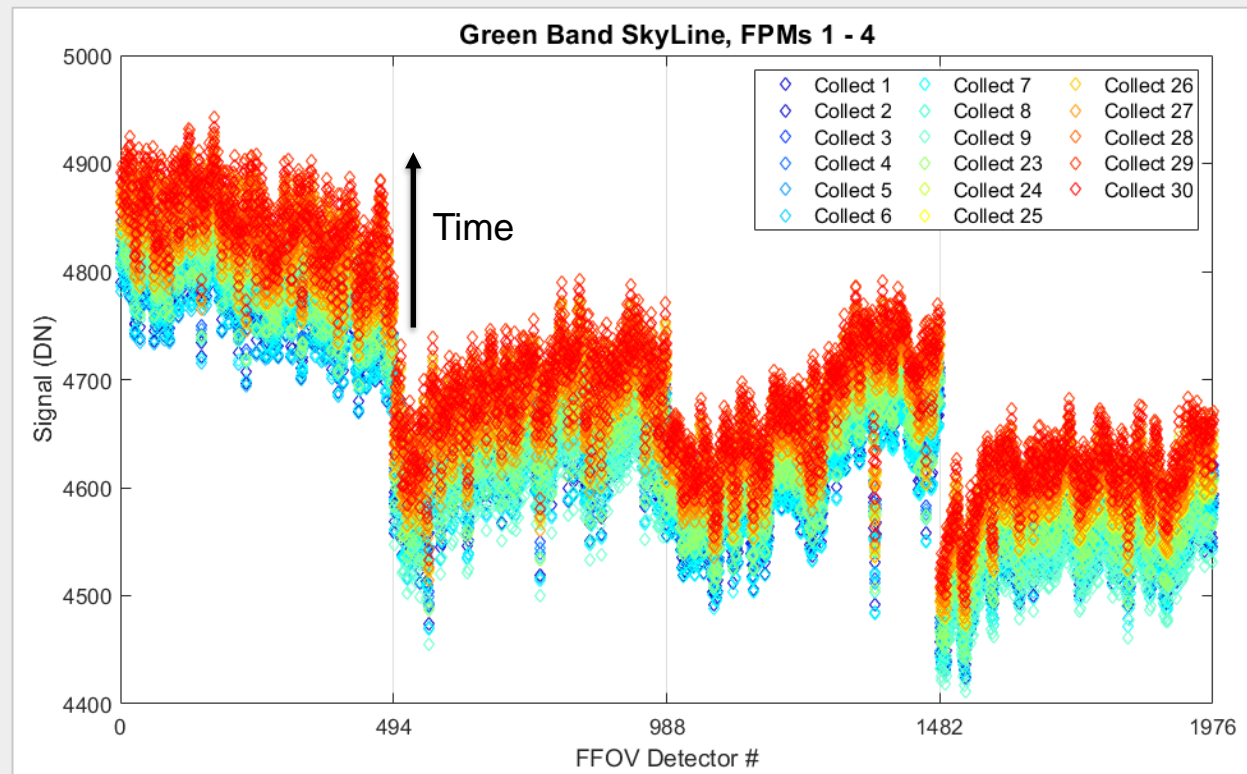





## Method 2: Radiance-Based Calculation



$$L_{bw,b,d}(t) = \frac{L_{bw,b,d}(t_{CATS}) D^2(t_{CATS})}{\tau_{helio,b} \tau_{atm,b} D^2(t)}$$

Atmospheric Transmittance  $\tau_{atm,b}$

- Atmospheric transmittance was calculated for the times of the most similar diffuser images by the University of Arizona

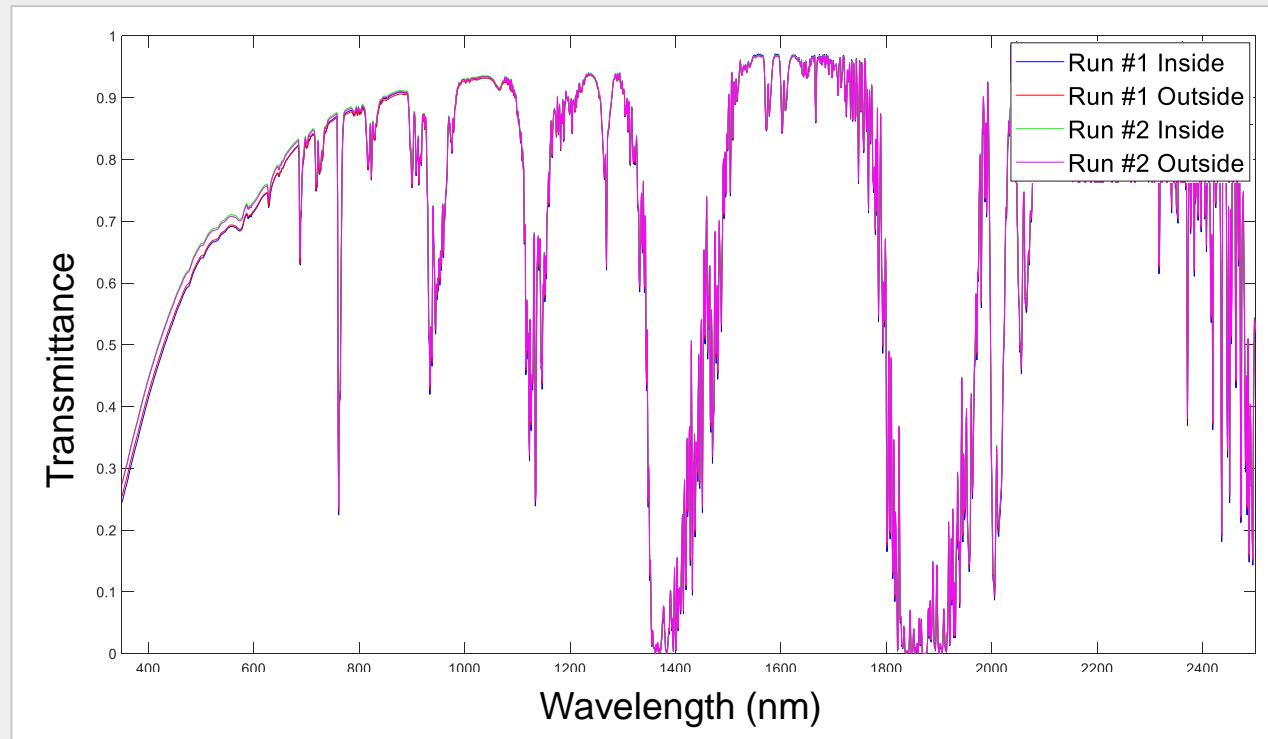



## Method 2: Radiance-Based Calculation



$$L_{bw,b,d}(t) = \frac{L_{bw,b,d}(t_{CATS})}{\tau_{helio,b} \tau_{atm,b}} \frac{D^2(t_{CATS})}{D^2(t)}$$

Earth Sun Distance at CATS testing

Earth Sun Distance

- Day of year is used to calculate earth-sun distance to correct solar irradiance

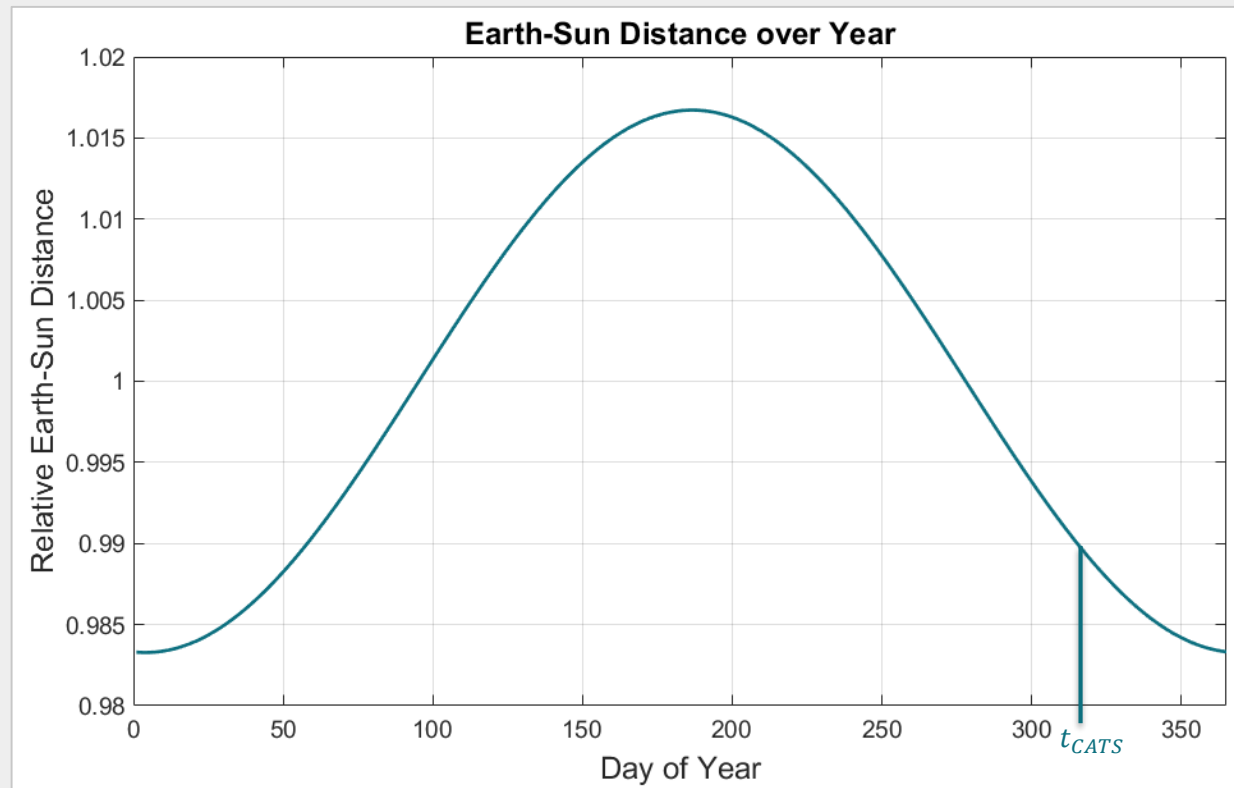



# TOA Prediction Preliminary Results



## OLI-2

SWIR1 : Spectral Radiance Predictions Method Comparison, 2018-11-20

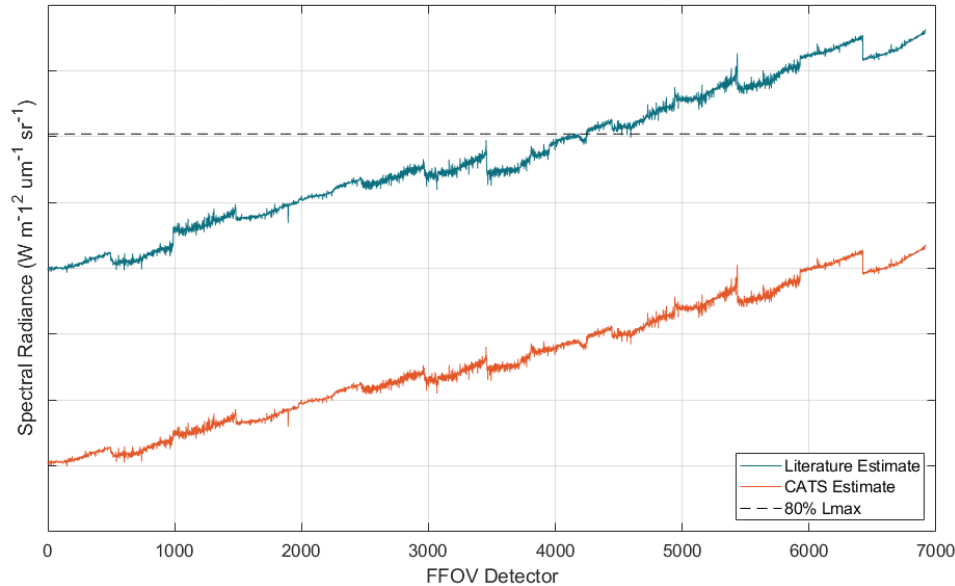

## OLI

Radiance values for baseline file L1R\_Diffuser\_Stats.mat  
Mean: 57.4621 STD: 0.88355

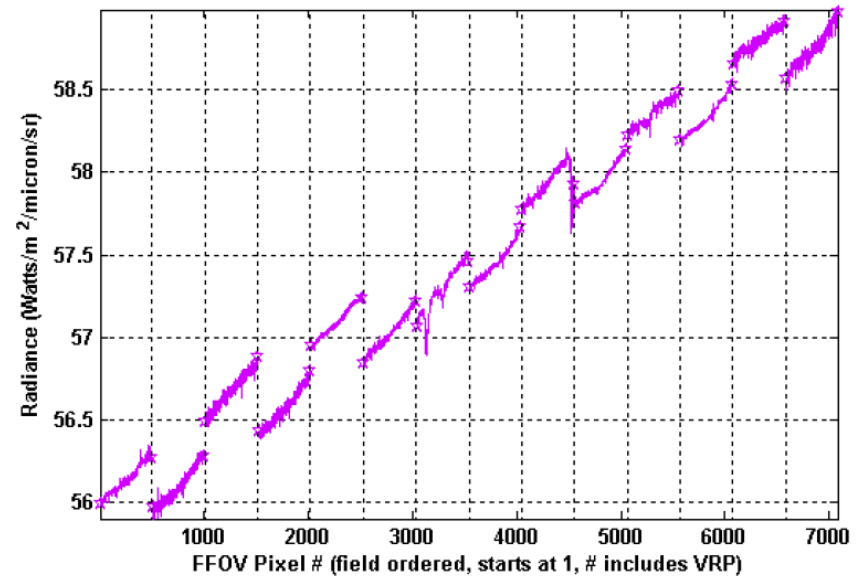

- See a preliminary agreement of up to 5% between the two TOA calculation methods
- See a preliminary agreement of up to 5% between OLI and OLI-2 data
- We will continue to refine these predictions



## Determine diffuser-calibrated bands



- **The subset of diffuser-calibrated bands can be determined by:**
  - Similar predictions from the two diffuser TOA radiance methods
  - Similar predicted and on-orbit radiance measurements reported on OLI
  
- **May also be informed by**
  - Quality of *Stim Lamp Fit Metric*
  - Agreement of different solar spectra
  - Similarity between OLI and OLI-2



# Calculate the Stim Lamp Bulb Color Temperature Fit



OLI-2, PRIMARY WORKING Bulb Pair, Collect 1, FPM 1 Detector 247

Wavelengths used for fit: CA-B-G-R-NIR-1SW

Min Temp Est 2790.4 K, Max Temp Est 2830.1 K

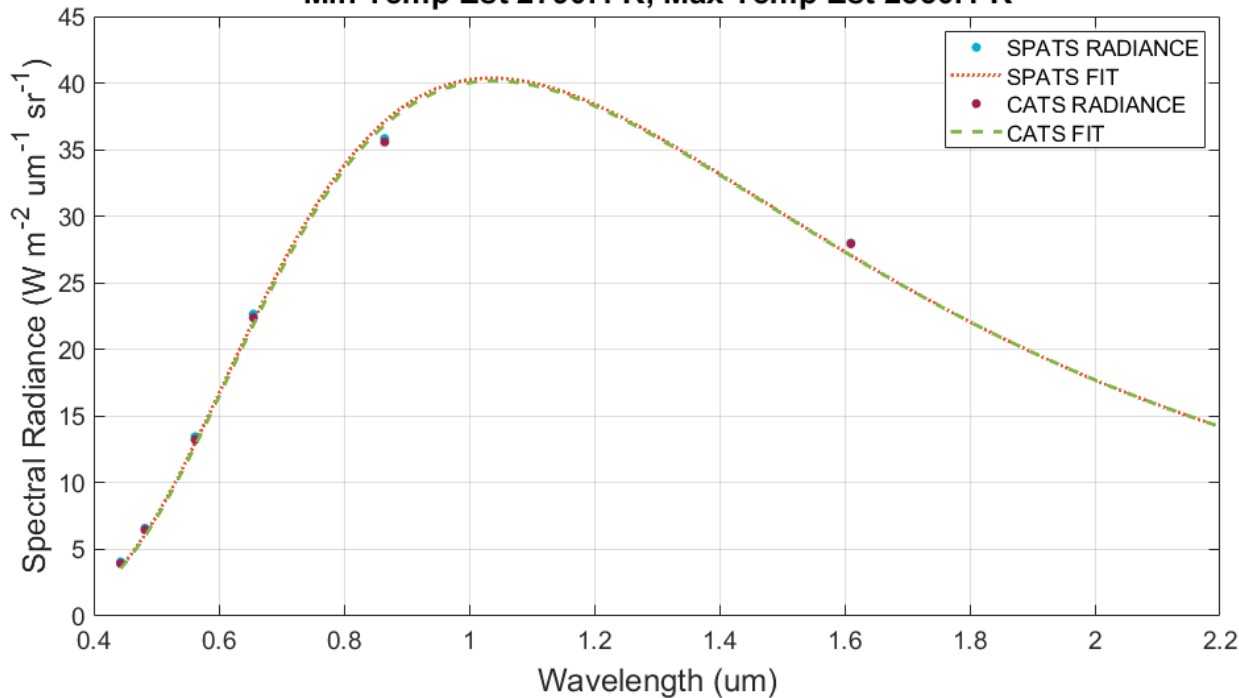

$$P_{\lambda}(\lambda, T) = \frac{c_1}{\lambda^5 \cdot e^{[(c_2/\lambda \cdot T) - 1]}}$$



# Calculate the Stim Lamp Bulb Color Temperature Fit



OLI-2, PRIMARY WORKING Bulb Pair, Collect 1, FPM 1 Detector 247  
Wavelengths used for fit: CA-B-G-R-NIR-1SW  
Min Temp Est 2790.4 K, Max Temp Est 2830.1 K

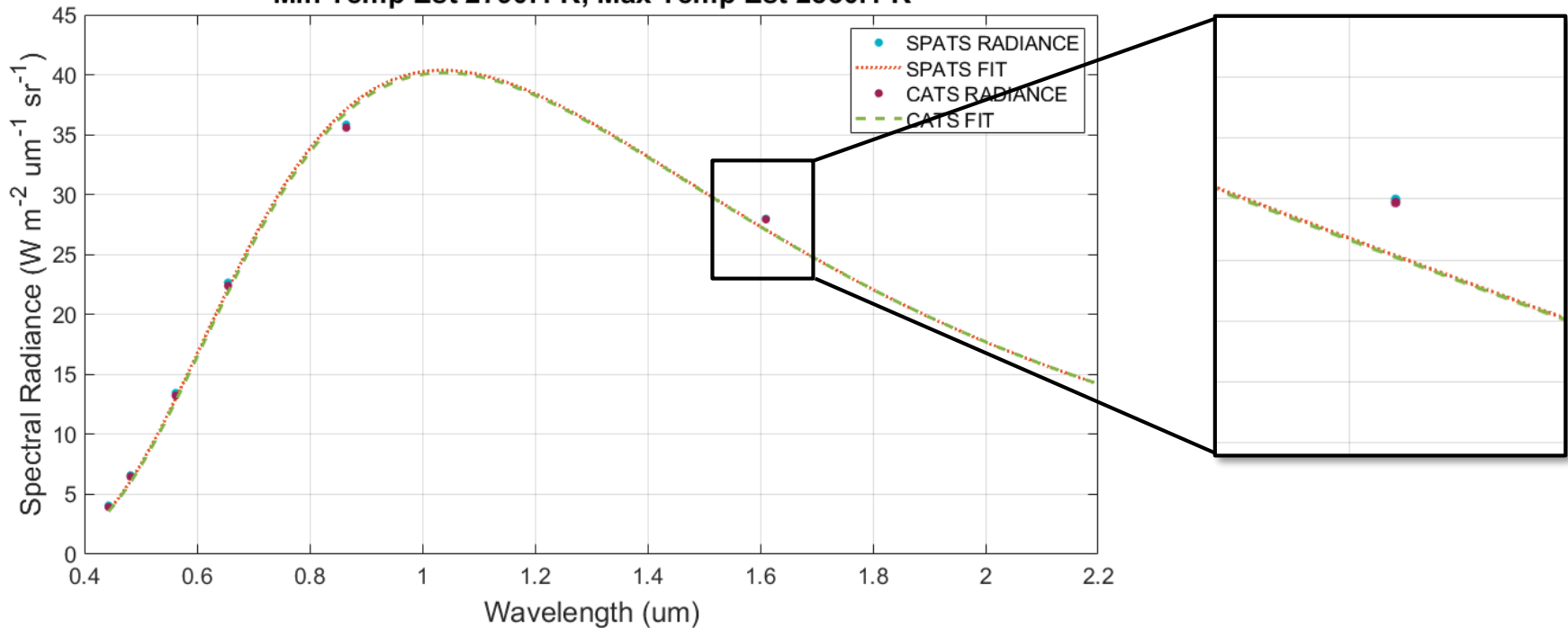

$$P_{\lambda}(\lambda, T) = \frac{c_1}{\lambda^5 \cdot e^{[(c_2/\lambda \cdot T) - 1]}}$$



# Calculate the Stim Lamp Bulb Color Temperature Fit



OLI-2, PRIMARY WORKING Bulb Pair, Collect 1, FPM 1 Detector 247

Wavelengths used for fit: CA-B-G-R-NIR-1SW

Min Temp Est 2790.4 K, Max Temp Est 2830.1 K

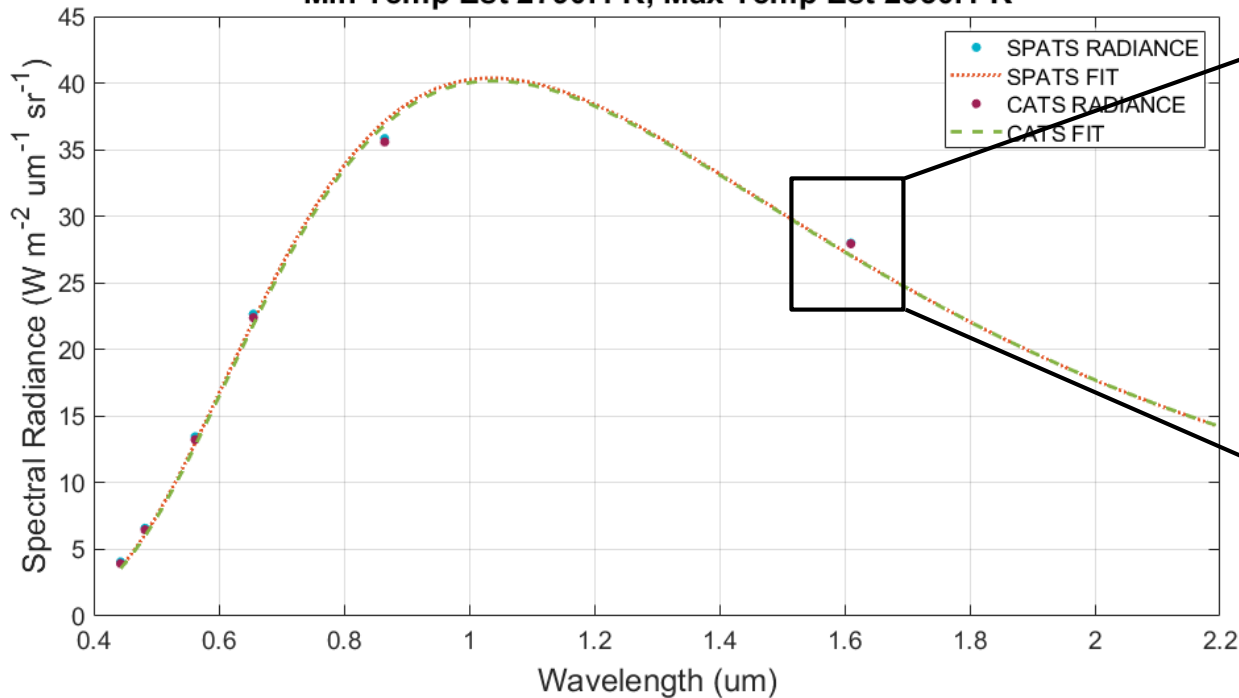

**Stim Lamp Fit Metric:**  
Radiance-to-Fit Residual

$$P_{\lambda}(\lambda, T) = \frac{c_1}{\lambda^5 \cdot e^{[(c_2/\lambda \cdot T) - 1]}}$$



# Color temperature fitting should be stable



- **Expect the color temperature to change on orbit due to vacuum, instrument orientation, and 0G**
  - Calibration Alignment Test Station (CATS) and Spatial Performance Test Station (SPATS) used different instrument orientation
  - SPATS/CATS were completed in vacuum while other collects were completed in ambient environments
  - See anticipated changes between different test campaigns
- **Expect the band fitting (Stim Lamp Fit Metric) to perform the same relative to the collected signal regardless of the environmental changes**
- **Cal coefficients are preliminary**

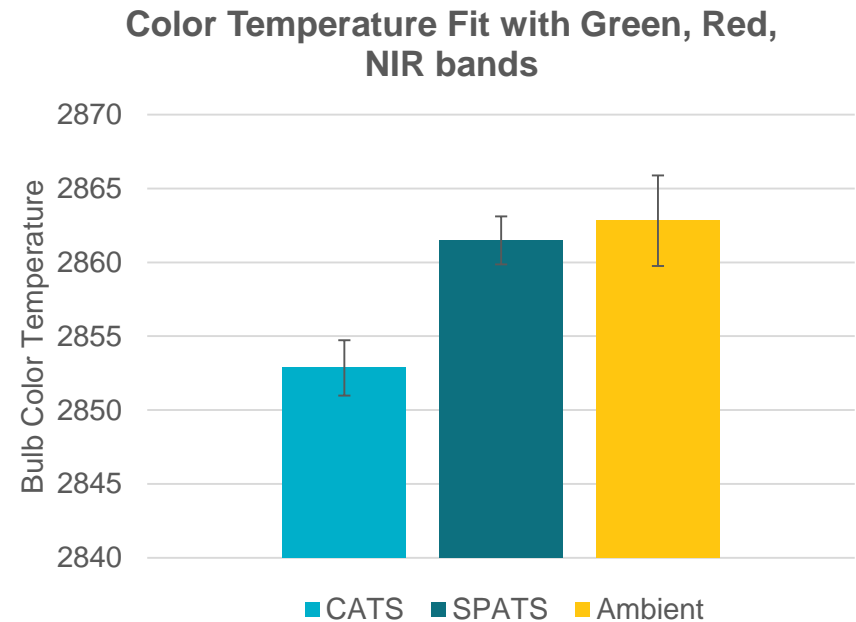





# The residuals of each band relative to the fit remain consistent despite the changes

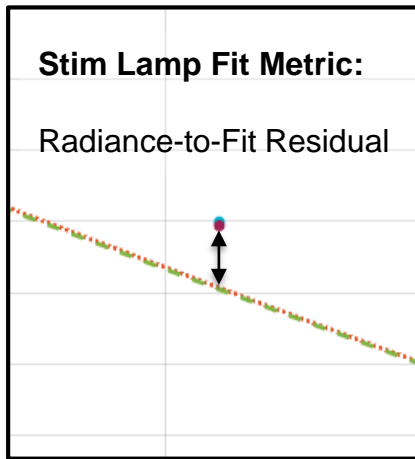

Fit with Green, Red, NIR bands

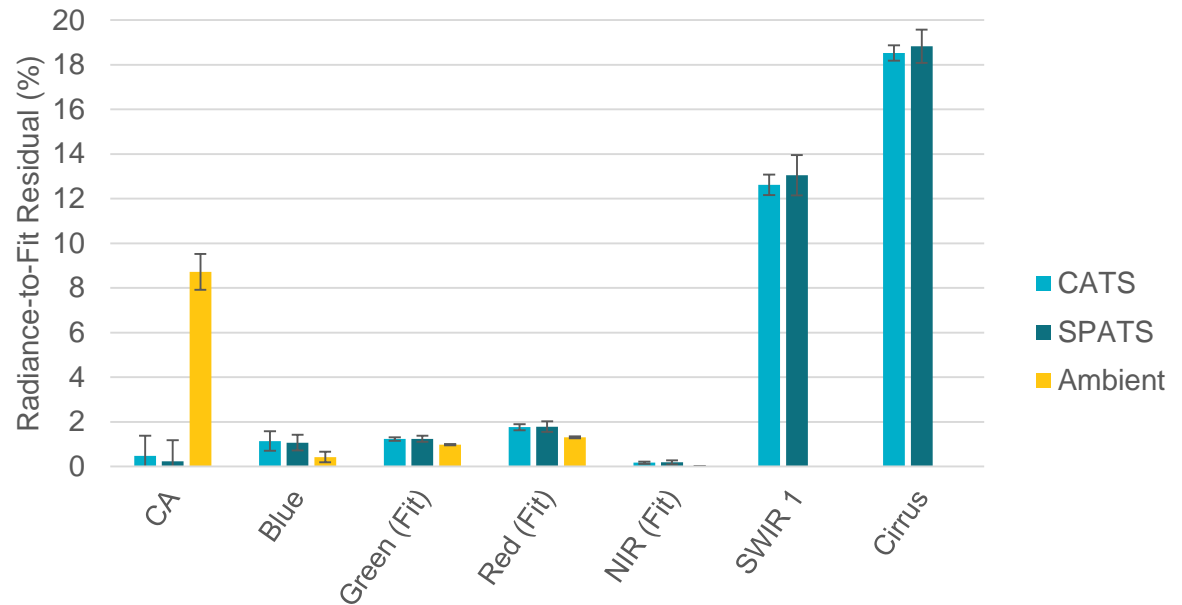

- Both between test campaigns and within test campaign, the fitting method is repeatable
- This residual can be used as a metric to fit bands relative to one another
- The residuals may offer an evaluation of the cal coefficients



# Bulb color temperature is highly repeatable with as few as 2 bands



- Choice of diffuser-calibration bands affects the quality of the bulb color temperature fit
- The quality of the fit can be highly repeatable
- Using more bands for the fit does not imply a better fit
  - Fit quality is measured by both magnitude and repeatability of residual

Standard Deviation of Residual Metric over CATS Collects

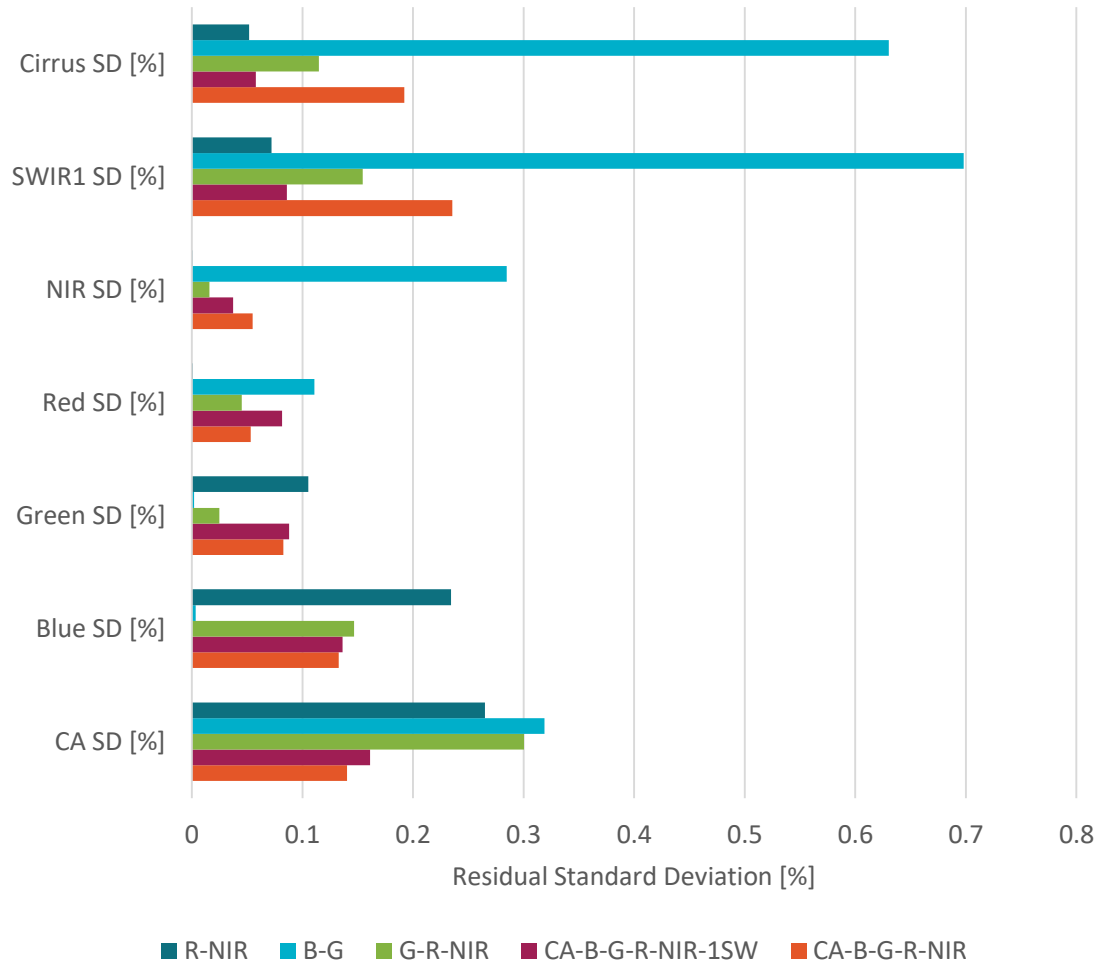



## Summary



- **The data we have collected through ground tests give us enough information to determine:**
  - **Diffuser-calibrated band subset through the diffuser measurements**
  - **Bulb temperature fitting parameters through the stim lamp measurements**
  
- **We will continue to refine the metrics for determining which subset of bands to use and coming up with these final parameters**
  
- **On orbit, we will collect data to**
  - **Compare diffuser TOA radiance measurements to predictions**
  - **Determine whether the cal coefficients changed**
  - **Use updated cal coefficients to fit the on orbit stim lamp images for all bands**



---

# Acknowledgments



- **Sandra Collins**
- **John Fleming**
- **Stu Biggar**
- **Eric Frater**
- **John Douglas**