

Yonago Acta medica 2003;46:133–144

Evaluation of Exhaled Nitric Oxide in Thoracic Surgery Patients under One Lung Ventilation Using a Newly Designed Online Exhaled Nitric Oxide Measuring System

Yukari Minami, Renyu Liu*, Yuichi Ishibe, Naoto Okazaki, Tae Funakoshi and Keiichiro Ueda

*Department of Surgery, Division of Anesthesiology and Critical Care Medicine, Tottori University Faculty of Medicine, and *Department of Anesthesia, University of Pennsylvania Medical Center, Philadelphia, PA 19104 United States*

Measurement of exhaled nitric oxide (NO) has been gaining much interest lately. However, an ideal measuring system is not yet available in the clinical setting. The aims of the present study were to construct an exhaled NO measuring system and to investigate the effects of one lung ventilation (OLV) on exhaled NO output in patients who underwent thoracic surgery. At first, the NO measuring system was constructed with an NO analyzer, a respiratory flowmeter and a data processing computer system in which the algorithm was indwelled for correcting the distorted NO output wave form. Then, accuracy of this system was tested by using a simulator. This simulator was reworked in order to simulate NO production from the lung under both spontaneous respiration and mechanical ventilation. The data of peak NO concentration (pNO) and NO output (VNO) obtained with the NO monitoring system were significantly correlated with “alveolar” NO concentration (aNO) and exhaled NO volume from the simulator. Then, exhaled NO was measured in 12 thoracic surgery patients who underwent OLV using this system. pNO and VNO were significantly decreased by about half during OLV, and returned to baseline 25 min after releasing OLV. These data suggest that the newly designed online exhaled NO measuring system accurately detected aNO and exhaled NO volume in a breath-by-breath manner, and OLV for about 3 h did not influence the NO output from the lung after releasing OLV in thoracic surgery patients.

Key words: exhaled nitric oxide; one lung ventilation; online measurement; simulator; thoracic surgery

The presence of endogenous nitric oxide (NO) in the exhaled air of animals (Gustafsson et al., 1991) and humans (Borland et al., 1993) has been reported. The exhaled NO level from the lungs has been affected by various pathophysiological conditions including inflammation (Belvisi et al., 1995; Hill et al., 1995), other respiratory diseases (Hill et al., 1995; Kharitonov et al., 1996), septic shock (Stewart et al.,

Abbreviations: aNO, alveolar nitric oxide concentration; BLV, bilateral lung ventilation; ETCO₂, partial pressure of end tidal carbon dioxide; mNO, mean nitric oxide concentration; NO, nitric oxide; OLV, one lung ventilation; PaO₂/F_IO₂, ratio of arterial partial pressure for oxygen to fractional inspired oxygen concentration; pNO, peak nitric oxide concentration; ppb, parts per billion; Q, respiratory flow rate; RR, respiratory rate; TV, tidal volume; τ , time constant; TV_{ex}, expiratory tidal volume; VNO, exhaled nitric oxide output

1995) and ischemia-reperfusion injury (Blebea et al., 1996).

A guideline was published to provide recommendations for a standardized procedure for exhaled NO measurement (American Thoracic Society, 1999), because differing methods may cause some misunderstanding of absolute exhaled NO concentration (Robbins et al., 1996; Byrnes et al., 1997). According to the recommendations of online NO measurement, NO output represents the amount of exhaled NO per unit time, and is calculated from the product of NO concentration and expiratory flow rate. A high quality of accuracy in a NO analyzer and flow sensor is required. However, the output wave form of the recently available fast response NO analyzer is still distorted because of unsatisfactory response time and delay time due to transit time through the sample tubing in a particular application. Therefore, it is necessary to correct the output wave form to obtain accurate real-time NO output. The 1st aim of the present study was to construct an online real-time exhaled NO measuring system in a breath-by-breath manner and to evaluate the accuracy and usefulness of this system.

One lung ventilation (OLV) is a special technique employed during thoracic surgery to separate both lungs and secure a large surgical field. In general, a controlled ventilation setting during OLV maintains tidal volume (TV) and respiratory rate

(RR) values similar to those used in bilateral lung ventilation (BLV). These ventilating conditions create a risk of lung injury for the ventilating lung because of a relatively high TV and consequent high airway pressure. Recently, OLV with TV and zero end-expiratory pressure values similar to those used in BLV have been reported to deteriorate pulmonary mechanics, to induce pulmonary hypertension and also to increase the release of thromboxane B2 in an isolated rabbit lung model (Gama et al., 2003). Furthermore, the effects of OLV on exhaled NO have not been investigated. We hypothesized that lung injury might be caused by OLV and exhaled NO output might change after releasing OLV. The 2nd aim of the present study was to measure exhaled NO and to investigate the effects of OLV on NO production from the lungs of patients who underwent thoracic surgery.

Subjects and Methods

Construction and evaluation of a real-time exhaled NO measuring system

System setup

The measuring system consisted of an NO gas analyzer, a respiratory flowmeter, a capnometer and a data-collecting computer system (Fig. 1). The

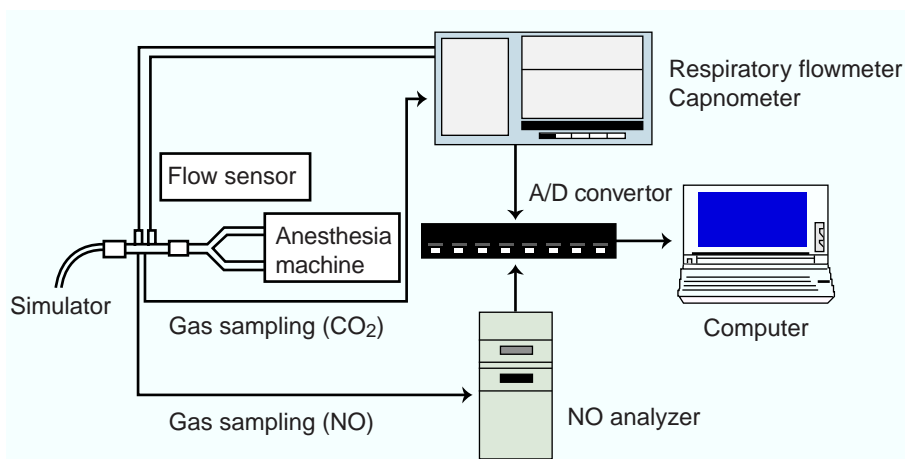

Fig. 1. Setup of the online exhaled nitric (NO) measuring system. The system consists of a simulator, an anesthesia machine, an NO analyzer, a capnometer and a respiratory flowmeter. Output of these data are digitized and recorded in the computer for secondary processing.

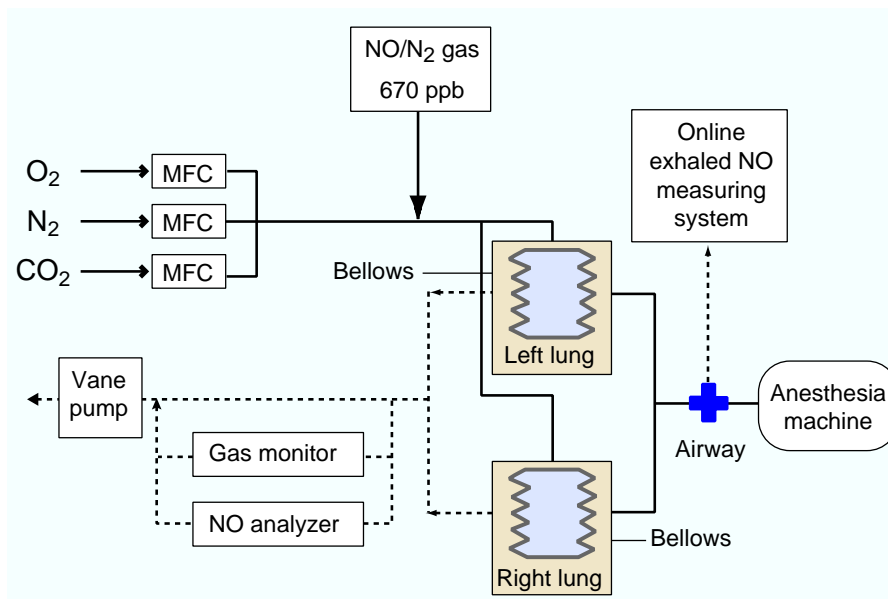

Fig. 2. Relationship of the simulator, anesthesia machine and online exhaled NO measuring system. To simulate nitric oxide (NO) production from the bellows of the simulator, the standard NO gas is infused into the alveolar component gas in the bellows, which is regulated by a mass flow controller (MFC). Exhaled NO parameters and alveolar NO concentration are measured using an online exhaled NO measuring system and an NO analyzer in breath-by-breath manner, respectively. See the text for details.

concentration of NO was measured with an NO analyzer (NOA 280, software version 2.05, Sievers Instruments, Boulder, CO), based on the chemiluminescence method with a sampling volume of 200 mL/min. The CO₂ concentration and respiratory flow rate (Q) were simultaneously monitored by a multi-parameter airway gas monitor (Capnomac Ultima, Datex-Engstrom Division, Instrumentation Corporation, Helsinki, Finland). The original NO, CO₂ and Q data were digitized by the MacLab system, which consists of a MacLab hardware unit (MacLab/400, AD Instruments, Castle Hill, Australia) and a software application program (Chart, version 3.5, AD Instruments), and processed as described below.

Correction of the original NO wave

Accurate drawing of NO concentration waves and gas flow rate is critical for ensuring reproducible measurements, but several factors distort the output waves from the analyzer. Major factors are sampling tube volume connected to the analyzer and delay in the response chamber of the chemiluminescence reaction. Using this system, 10 consecutive response curves were obtained by switching the sample gas from NO free air to standard NO gas (NO 670 parts per billion in N₂, Taiyo Toyo Sanso, Osaka, Japan), and delay time and 2 time constants (τ_1 and τ_2) were obtained. Then, the

original NO wave was corrected using the 2-exponential correction based on the report by Arieli and Van Liew (1981).

Calculation of exhaled NO output

This system can display real-time waves breath-by-breath, and record the processed data for peak NO concentration (pNO), mean NO concentration (mNO) and exhaled NO output (VNO) in tidal ventilation. The VNO is calculated by numerical integration of the product of the NO concentration and flow rate as defined in the guideline (American Thoracic Society, 1999).

Evaluation of the online NO measuring system using the simulator

The human patient simulator (METI, Inc., University of Florida, Sarasota, FL) was connected to the semiclosed anesthesia machine (Ohmeda, Modulus II, BOC Health Care, Madison, WI) through the end of the tracheal tube. The sensors of the online NO measuring system were interposed between the end of the tracheal tube and the respiratory circuit of the anesthesia machine as shown in Fig. 2. The simulator reproduces the airway pressure flow characteristics of the natural lung under normal and pathophysiological conditions. Uptake and delivery of the following “alveolar” gases in-

side the bellows are physically created by gas substitution, that is, O₂, CO₂ and N₂. We connected the NO infusion line to the bellows. Using the gas substitution technique, a constant flow of “alveolar” gas is sent from the bellows by a vane pump. A portion of this gas is sampled by a gas analyzer, which determines the partial pressures of O₂ and CO₂. “Alveolar” NO concentration (aNO) was determined by online NO gas analyzer (NOA 280), which was set parallel to the gas analyzer (Fig. 2). Inspiratory and expiratory gas compositions could thus be measured with a standard monitor (Capnomac Ultima), and expired NO gas concentration was measured with the NO gas analyzer. We selected “standard man awake” and “standard man relaxed” scenarios preconfigured by the manufacturer for measurements during spontaneous breathing and controlled ventilation, respectively.

Respiratory parameters such as TV (mL), RR (breath/min) and partial pressure of end tidal carbon dioxide (ETCO₂, kPa) were adjusted according to our study protocol. These respiratory parameters were regulated by setting the simulator during spontaneous breathing and setting the respirator on the anesthesia machine during controlled ventilation. The standard NO gas was infused into the lung component gases of the bellows of the simulator to simulate NO production from the lung, by changing the infused NO gas flow rate of 45 or 90 or 180 mL/min, which is equivalent to NO production of approximately 30.2 or 60.3 or 120.6 nL/min, respectively. After aNO in the bellows reached a constant value, aNO and all exhaled NO parameters (pNO, mNO and VNO) were measured.

Study protocol

Exhaled NO parameters of pNO, mNO, VNO and aNO were measured by changing ETCO₂ 4.2 ± 0.1 kPa (hyperventilation) or 5.4 ± 0.1 kPa (normoventilation) or 6.4 ± 0.2 kPa (hypoventilation), while keeping a constant infused NO flow rate (180 mL/min). Subsequently, the same parameters were measured by changing the infused NO flow rate to 90 or 45 mL/min while keeping ETCO₂ 5.4 ± 0.1 kPa (normoventilation). While keeping the same ETCO₂ conditions, the combination of TV and RR

was changed 4 times and parameters were measured. These series of measurements were repeated under both spontaneous breathing (*n* = 20) and controlled ventilation (*n* = 19).

Application of the online real-time NO measuring system to thoracic surgery patients

As this is a prospective and observational study without intervention other than specific monitoring procedures, the Ethical Committee of Tottori University Faculty of Medicine approved this study without obtaining informed consent from the patients. Exhaled NO was measured in 12 patients undergoing thoracic surgery during which OLV was required. To provide a control, exhaled NO was also measured in 5 non-thoracic surgery patients, who did not require OLV during surgery.

The patients were premedicated with 25 to 50 mg hydralazine and 0.5 mg atropine intramuscularly. After induction with 2.0 mg/kg propofol, 5 µg/kg fentanyl and 0.05 mg/kg pancuronium, anesthesia was maintained with propofol and fentanyl. No inhalational volatile anesthetics were used because exhaled NO is underestimated in the presence of potent inhalational volatile anesthetics (Liu et al., 2000). Thoracic epidural anesthesia was also applied in some patients of both groups. The trachea of each patient was intubated with a double lumen endobronchial tube. Surgery was performed with OLV by collapsing the non-dependent lung in the lateral decubitus position. The lungs of patients were ventilated with a TV of 10 to 12 mL/kg at a rate of 10 breaths/min during BLV. Respiratory minute volume was kept constant during NO measurement by adjusting both TV and RR to keep ETCO₂ at about 3.5 to 4.5 kPa. During OLV, respiratory minute volume was adjusted to maintain the same level of ETCO₂ as that during BLV. Arterial partial oxygen pressure was measured with a standard blood gas analyzer, and the ratio of arterial partial pressure for oxygen to fractional inspired oxygen concentration (PaO₂/F_IO₂) was calculated. Lung compliance was measured with multi-parameter airway gas monitor (Capnomac Ultima).

Data collection

The original data were recorded just before OLV; 5, 20 and 60 min after beginning of OLV; just before reestablishment of BLV; and 5 and 25 min after reestablishment of BLV. The data for patients who underwent non-thoracic surgery were recorded before, during and after surgery.

Data analysis and statistics

pNO, mNO and VNO were calculated from a consecutive analysis of NO waves for 40 s and compared to aNO using a single linear regression test. Using the same statistical analysis, VNO was compared to the calculated exhaled NO volume, which was defined as aNO × expiratory TV (TV_{ex}) × RR. The parametric data of patient characteristics, respiratory parameters and blood gas data were presented as mean ± SD. Respiratory parameters and blood gas data were analyzed with analysis of variance with repeated measures and subsequent post hoc test. As exhaled NO parameters were not distributed uniformly with the Bartlett test, they were analyzed by the nonparametric analysis of Friedman’s χ^2 -test, and when statistical significance was observed, a subsequent Wilcoxon’s *t*-test with Bonferroni’s correction was performed. Commercially available software (Statview, version 4.5

Abacus Concepts, Berkeley, CA) was used for the statistic analysis and *P* < 0.05 was considered to be statistically significant.

Results

Drawing of the real-time NO wave and evaluation of the measuring system

Delay time of the 10 consecutive measurements was 2.1675 ± 0.0736 s. Mean time constants were 0.1208 ± 0.0089 s and 0.5656 ± 0.0075 s in τ_1 and τ_2 , respectively. Consequently, the distorted output curve for NO was corrected by the following formula for C:

$$C = C_0 + (\tau_1 + \tau_2) \times dC_0/dt + \tau_1 \tau_2 \times d^2C_0/dt^2 \\ = C_0 + 0.6863 dC_0/dt + 0.0683 d^2C_0/dt^2$$

where C_0 is the original NO concentration, C is corrected NO concentration and t is time.

The representative corrected NO is shown combined with waves of original NO, CO₂ and Q in Fig. 3. Respiratory parameters of the simulator are summarized in Table 1. aNO decreased according to the increase in respiratory minute volume.

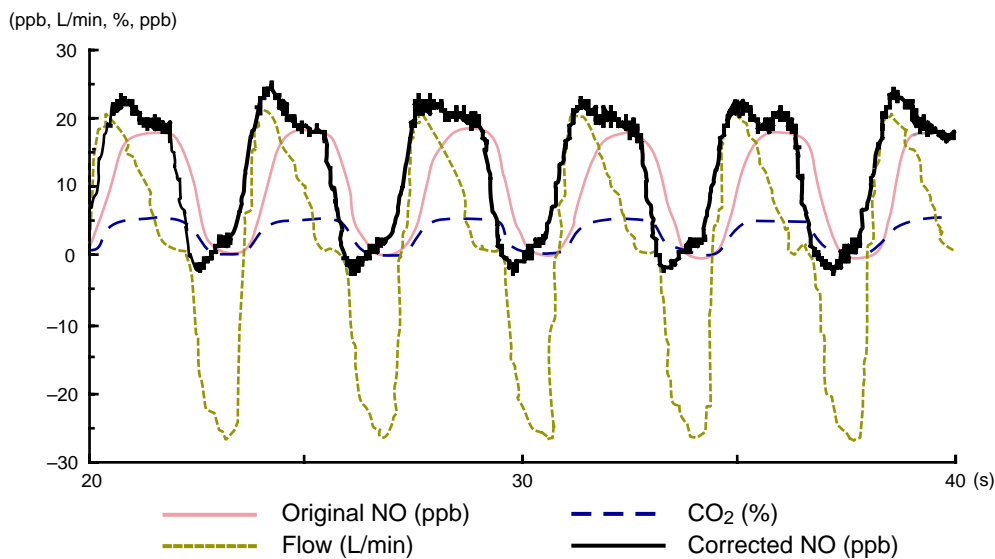

Fig. 3. Representative traces of original nitric oxide (NO), corrected NO, carbon dioxide (CO₂) and gas flow after time phase adjustment. Time phase adjustment and NO wave correction are described in the text for details. ppb, parts per billion.

Table 1. Characteristics of the simulator

Infused NO	Respiratory condition	Spontaneous breathing				Controlled ventilation			
		ETCO ₂	RR	TV _{ex}	aNO	ETCO ₂	RR	TV _{ex}	aNO
180 mL/min	Hyper-ventilation	4.4	6.4	735	21.4	4.1	6.0	1006	17.8
		4.3	10.6	857	15.5	4.3	9.7	1333	12.8
		4.1	15.0	600	15.7	4.4	15.3	692	14.5
		4.3	20.3	409	17.9	4.1	20.1	635	12.9
	Normo-ventilation	5.5	6.7	516	24.2	5.5	6.0	571	24.1
		5.5	11.3	439	21.0	5.3	10.4	526	20.3
		5.5	16.6	388	19.3	5.5	16.1	411	19.6
		5.3	20.5	334	19.7	5.5	21.1	308	21.0
	Hypo-ventilation	6.4	5.2	354	29.3	6.3	6.0	368	27.5
		6.5	10.0	297	26.8	6.3	10.1	206	31.2
		6.7	13.4	319	23.0	6.1	15.1	134	34.8
		6.4	19.5	261	22.7	–	–	–	–
90 mL/min	Normo-ventilation	5.5	7.0	544	13.4	5.3	6.0	669	12.0
		5.5	12.2	460	11.9	5.3	10.1	526	11.4
		5.5	17.1	404	11.0	5.5	15.3	439	10.7
		5.3	20.4	351	10.9	5.2	20.3	376	9.9
45 mL/min	Normo-ventilation	5.3	6.4	529	8.7	5.5	6.0	451	8.2
		5.5	12.1	451	7.9	5.3	10.1	517	7.0
		5.5	17.1	415	7.0	5.3	14.7	506	6.1
		5.3	20.4	362	7.3	5.5	20.1	341	6.4

aNO, alveolar nitric oxide concentration (ppb); ETCO₂, partial pressure of end tidal carbon dioxide (kPa); infused NO, infused flow rate standard nitric oxide gas (670 ppb) into the bellows of the simulator; RR, respiratory rate (rate per minute); TV_{ex}, expiratory tidal volume (mL); –, not performed.

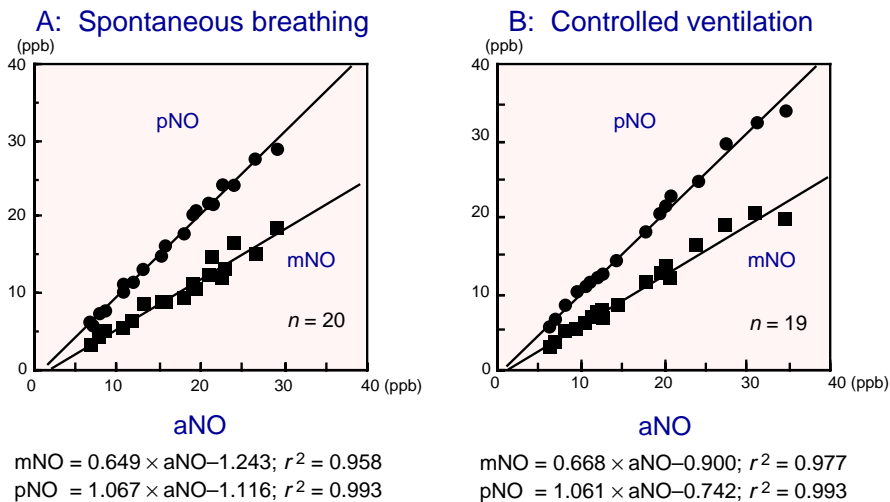

Fig. 4. Peak nitric oxide concentration (pNO) and mean nitric oxide concentration (mNO) in a tidal breath significantly correlated with alveolar nitric oxide concentration (aNO) during spontaneous breathing (A) and during controlled ventilation (B).

Both pNO and mNO significantly correlated with aNO during spontaneous breathing ($n = 20$, Fig. 4A) and controlled ventilation ($n = 19$, Fig.

4B). In particular, pNO coincided with aNO under a wide range of respiratory patterns. When the standard NO gas was infused into the bellows of the

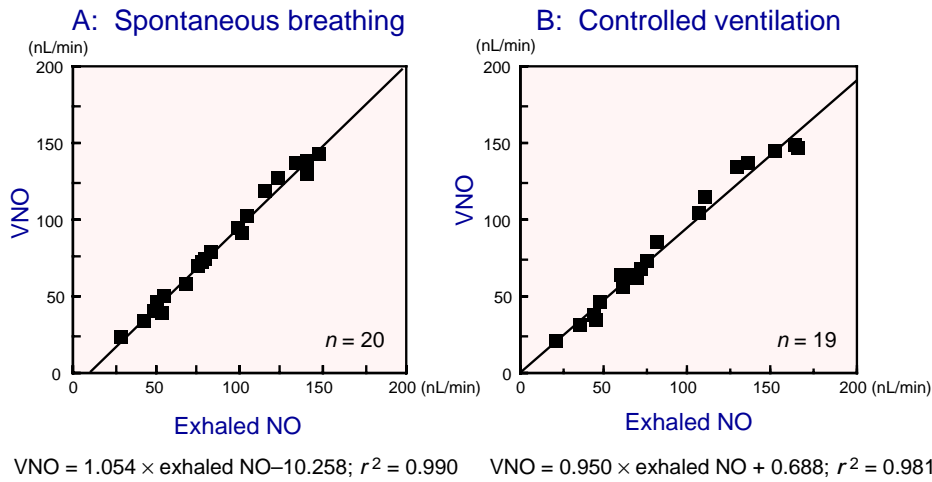

Fig. 5. Exhaled nitric oxide output (VNO) significantly correlated with exhaled NO volume during spontaneous breathing (A) and during controlled ventilation (B). Exhaled NO volume was defined as the products of alveolar nitric oxide concentration (aNO), expiratory tidal volume (TV_{ex}) and respiration rate (RR).

stimulator at rates of 45, 90 and 180 mL/min, aNO yielded 40.4 ± 9.9 nL/L (n = 8), 66.4 ± 11.3 nL/L (n = 8) and 111.9 ± 33.7 nL/L (n = 23), respectively. VNO correlated significantly with the actually exhaled NO volume (aNO × TV_{ex} × RR) from the simulator regardless of changes in respiratory patterns during both spontaneous breathing (Fig. 5A) and controlled ventilation (Fig. 5B).

Measurement on thoracic surgery patients

The characteristics of the patients are shown in Table 2. The mean duration of OLV was about 3 h. In non-thoracic surgery, TV/kg, RR and ETCO₂ were maintained constantly during surgery. In thoracic surgery, TV/kg and RR significantly

changed during OLV. These variables returned to baseline after releasing OLV (BLV-5 and 25) (Fig. 6).

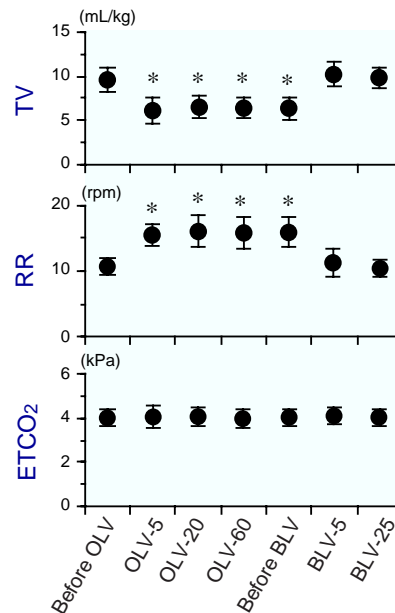

Fig. 6. Changes in tidal volume per body weight (TV/kg), respiratory rate (RR) and end tidal CO₂ (ETCO₂) in thoracic surgery. Data were collected before OLV, just before one lung ventilation (OLV); OLV-5, 5 min after beginning of OLV; OLV-20, 20 min after beginning of OLV; OLV-60, 60 min after beginning of OLV; before BLV, just before reestablishment of bilateral lung ventilation (BLV); BLV-5, 5 min after reestablishment of BLV; BLV-25, 25 min after reestablishment of BLV. Values are mean ± SD. *P < 0.05, different from before OLV. ETCO₂ was in physiological ranges resulting in reduced TV and increased RR during OLV.

Table 2. Characteristics of the patients

	Thoracic surgery	Non-thoracic surgery
Number of patients	12	5
Age (year)	57.9 ± 20.6	54.2 ± 15.8
Height (cm)	156.5 ± 9.9	161.5 ± 11.3
Weight (kg)	50.9 ± 7.3	65.1 ± 19.3
Surgery time (h:m)	4:09 ± 2:17	2:44 ± 2:09
OLV time (h:m)	3:13 ± 1:26	–

Values expressed as mean ± SD. h:m, hour:minute; OLV, one lung ventilation; –, not performed.

Table 3. Changes in PAW, CL and PaO₂/FIO₂

	Before OLV	During OLV	After OLV
PAW (kPa)	1.7 ± 0.2	2.3 ± 0.3*	2.0 ± 0.3†
CL (mL/kPa)	495 ± 158	250 ± 93*	402 ± 112*†
PaO ₂ /FIO ₂	65.3 ± 8.9	20.0 ± 11.1*	57.8 ± 13.6†

Values expressed as mean ± SD.

CL, lung compliance; OLV, one lung ventilation; PaO₂/FIO₂, ratio of arterial partial pressure for oxygen to fractional inspired oxygen concentration; PAW, peak airway pressure.

* *P* < 0.05 versus before OLV; † *P* < 0.05 versus during OLV.

In thoracic surgery, peak airway pressure significantly increased during OLV but returned after reestablishment of BLV. Lung compliance significantly decreased during OLV and increased after

OLV but still sustained a low level compared to baseline. PaO₂/FIO₂ decreased during OLV but returned to baseline after reestablishment of BLV (Table 3).

In thoracic surgery, pNO (*P* = 0.0084), mNO (*P* = 0.027) and VNO (*P* = 0.0056) significantly decreased during OLV. These variables returned to baseline after releasing OLV (BLV-5 and 25) (Fig. 7). In non-thoracic surgery, there were no changes in pNO, mNO and VNO during surgery (Fig. 8).

Discussion

We redesigned the online real-time system to measure exhaled NO. The NO wave was corrected by measuring actual delay time and 2 time constants.

Fig. 7. Changes in peak nitric oxide concentration (pNO), mean nitric oxide concentration (mNO) and exhaled nitric oxide output (VNO) in thoracic surgery. Data were collected before OLV, just before one lung ventilation (OLV); OLV-5, 5 min after beginning of OLV; OLV-20, 20 min after beginning of OLV; OLV-60, 60 min after beginning of OLV; before BLV, just before reestablishment of bilateral lung ventilation (BLV); BLV-5, 5 min after reestablishment of BLV; and BLV-25, 25 min after reestablishment of BLV. In this box and whisker plot, the central line represents the median, boxes represent the 25th and 75th percentiles, and whiskers represent the 10th and 90th percentiles. **P* < 0.05, different from before OLV. All exhaled parameters decreased during OLV and returned to before-OLV values up till 25 min after the reestablishment of BLV.

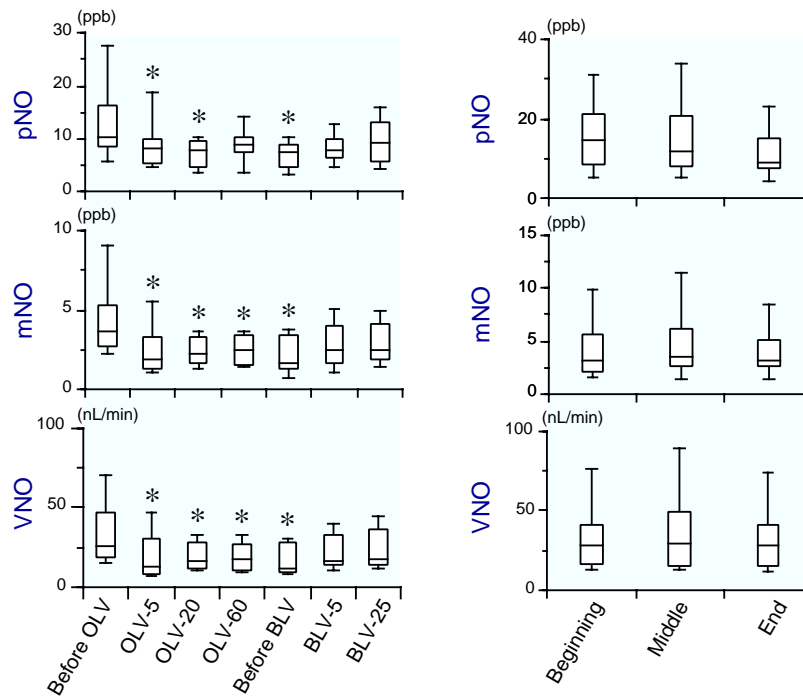

Fig. 8. Changes in peak nitric oxide concentration (pNO), mean nitric oxide concentration (mNO) and exhaled nitric oxide output (VNO) in non-thoracic surgery. Data were collected at the beginning, beginning of operation; middle, middle of operation; and end, end of the operation. In this box and whisker plot, the central line represents the median, boxes represent the 25th and 75th percentiles, and whiskers represent the 10th and 90th percentiles. No exhaled nitric oxide parameters changed significantly throughout the study.

This system was able to detect “alveolar” NO and exhaled NO volume accurately in a breath-by-breath manner, regardless of changes in respiratory minute volume and respiratory patterns during both spontaneous breathing and controlled ventilation.

Fast response analyzers are widely used to measure gas concentration during the breathing cycle. The amount of gas entering or leaving the lungs is calculated by a numerical integration of the product of analyzer’s output concentration and flow rate. A typical example is CO₂ output measurement using capnogram and pneumotachogram, both of which have sufficient performance to respond to rapid changes of CO₂ concentration and Q. Exhaled NO can likewise be analyzed by a fast response NO analyzer. A fast response chemiluminescence analyzer such as a Sievers NOA for exhaled NO measurement has a high performance fast response time, but its output wave is still distorted, resulting in misleading of readings when employed to detect peak concentration or the area under a curve. Large errors may be produced in real-time online exhaled NO measurements, if used without correcting the output curve. Although the output of the analyzer for step-change inputs is a sigmoid rather than an exponential function, a simpler empirical approach was applied with a 1-exponential correction of the output. However, we could obtain satisfactory results of reliable and reproducible measurements of NO using a 2-exponential correction to restore distortion of the curve. Exact correction of delayed time due to sampling tubes is also critical, especially in phase adjustment between NO concentration and flow rate. In general, the respiratory flow pattern, which is detected by the inline flow sensor, is applied as a standard technique for time phase adjustment because various sensing techniques are highly sensitive to flow changes. Therefore, we required flow patterns measured with pneumotachograms.

We infused NO into the bellows of the simulator. The NO concentration of constantly flowing gas sent from the bellows was defined as aNO, and $aNO \times TV_{ex} \times RR$ were defined as exhaled NO volume. Simulating the constant NO production from

the lung by keeping a constant infused volume of NO (180 mL/min) in the bellows, we changed the ETCO₂ from 4.0 to 6.5 kPa. aNO decreased according to the increase in respiratory minute volume and vice versa. Exhaled NO parameters of pNO and mNO strongly correlated with the changes in aNO. In particular, pNO readings represented the aNO level. Changes in combination of TV and RR under the same respiratory minute volume did not influence the readings of pNO and mNO. VNO represented actually exhaled NO volume from the simulator even when changing the infused NO volume. These data suggest that pNO measured with this system reflect aNO whenever a wide range of changes occur in TV and RR. Furthermore, VNO exactly reflected the exhaled NO volume regardless of changes in respiratory patterns and infused NO volume.

We are able to take this system to the bedside as all analyzers and standard gas are mounted on a trolley combined with a MacLab system and laptop personal computer. Taken together with these considerations we believe this system could be a useful tool for real-time exhaled NO measurements, not only in the laboratory but also in critical care such as during anesthesia, postoperative intensive care and respiratory care in medicine.

Using this system, we have shown that OLV for about 3 h did not affect NO output from the lungs after releasing OLV. To our knowledge, effect of OLV on exhaled NO output have not been investigated previously.

The data on exhaled NO parameters of pNO and VNO before OLV were at the same level as previously reported by investigators (Törnberg et al., 2003). Therefore, it was thought that this system had enough accuracy for clinical application. These parameters rapidly decreased by 40 to 70% during OLV. According to the results of this study in the 1st half, pNO and VNO represent alveolar NO concentration and actually exhaled NO volume from the lung, respectively, if there was no production or consumption during passage through the lower airway tract. Theoretically, pNO represents aNO, whereas VNO represent the actual exhaled NO volume, but not NO production from the lung,

because a large amount of alveolar NO rapidly diffuses into the pulmonary circulation, combining with hemoglobin in the capillary blood flow. Therefore, pulmonary blood flow is considered to be an important regulating factor of aNO and exhaled NO volume. These pulmonary circulation effects have been shown very effectively in a laboratory study by Fernández and colleagues (2003), who reported a clear increase of exhaled NO by balloon occlusion of the pulmonary artery. Increases in exhaled NO after atrial septal defect closure are also a clinical finding, indicating the role of the pulmonary blood flow effect on exhaled NO level (Humpl et al., 2002). As the ventilation area was almost halved during OLV, it is likely that aNO might be halved if minute ventilation was maintained at the same level as before OLV, when NO production from the lung was kept constant. In practice, however, a relative increase in respiratory minute volume to the dependent lung during OLV may further facilitate this reduction of pNO. VNO decreased about by half during OLV. This is not surprising because the ventilation area decreased by half during OLV. The present study was performed in the lateral decubitus position, under which pulmonary blood flow in the dependent lung increases by about 10% (Wulff and Aulin, 1972; Rehder et al., 1973). The hypoxic pulmonary vasoconstriction of the collapsed lung promotes the pulmonary blood flow shift to the dependent lung, yielding the blood flow to the dependent lung of 70 to 80% of the cardiac output during OLV (Fiser et al., 1982; Rogers and Benumof, 1985). Therefore, a relative increase in pulmonary blood flow to the dependent lung might contribute to a reduction of exhaled NO.

After releasing OLV, all parameters of exhaled NO returned to levels before OLV. This finding has 2 clinical implications. The collapsed non-dependent lung might not be injured during the collapse and re-expansion process, and be almost completely re-expanded after releasing OLV. Furthermore, the ventilated dependent lung might be protected against barotrauma or volutrauma during OLV. Sustained oxygenation and relative high lung compliance after releasing OLV suggest normal

lung function even after OLV for 3 h, although the collapsed non-dependent lung did not yet completely expand after 25 min after reestablishment of BLV. Our findings agree with the report by Oka and colleagues (1998) that OLV for about 3 h did not affect resistance and reactance in respiratory system after re-expansion. Acute re-expansion of the collapsed lung for a prolonged period leads to the development of pulmonary edema, and high tidal and high pressure ventilation induces respirator-induced lung injury (Dreyfuss et al., 1995; Broccard et al., 1999). Prolonged OLV or inappropriate ventilation patterns during OLV might reduce NO production, resulting in lung injury and affect lung function. The lung's protective ventilation strategies (Amato et al., 1998), low TV and positive end-expiratory pressure, are suggested to reduce lung injury due to volutrauma and barotrauma. Our ventilation pattern, relatively low TV and increased RR, and short OLV time might contribute to prevent lung injury during OLV.

In the previous study we showed that NO output decreased after cardiopulmonary bypass accompanied by low lung compliance and returned by 16 h after cardiopulmonary bypass (Ishibe et al., 2000), but we could not follow up postoperatively in this study. After the end of thoracic surgery our patients were extubated from their tracheas in a short time. This measuring system restricts use under the spontaneous airway without tracheal intubation. Exhaled NO measurements are convenient and less invasive, and basal exhaled NO output reflects bronchiolar and alveolar epithelial activity, but the lower sensitivity of exhaled NO measurements is pointed out for detection capillary endothelial injury (Sartori et al., 1999). Kövesi and colleagues (2003) emphasized a stimulation test with intravenous nitroglycerin to reveal endothelial dysfunction after cardiopulmonary bypass. Further studies are required to elucidate the effect of OLV on lung function and NO output from the lung.

We redesigned the online real-time exhaled NO measuring system. This exhaled NO measuring system accurately reflected the alveolar NO concentration and exhaled NO volume from the simu-

lator. Using this system, we have shown that 3 h lung collapse and re-expansion did not influence NO output from the lung after releasing OLV in thoracic surgery patients.

Acknowledgments: The authors thank Professor Eiji Shimizu, Division of Internal Medicine and Molecular Therapeutics, Department of Multidisciplinary Internal Medicine, Professor Kazuo Yamada, Division of Medical Biochemistry, Department of Pathophysiological and Therapeutic Science, and Professor Shigeo Hino, Division of Virology, Department of Microbiology and Pathology, School of Medicine, Tottori University Faculty of Medicine, for their reviewing the manuscript.

Supported in part by Grant-in-aid No. 11671497 for Scientific Research from the Ministry of Education, Science, Sports and Culture of Japan.

References

- Amato MB, Barbas CS, Medeiros DM, Magaldi RB, Schettino GP, Lorenzi-Filho G, et al. Effect of a protective-ventilation strategy on mortality in the acute respiratory distress syndrome. *N Engl J Med* 1998;338:347–354.
- American Thoracic Society. Recommendations for standardized procedures for the on-line and off-line measurement of exhaled lower respiratory nitric oxide and nasal nitric oxide in adults and children-1999. *Am J Respir Crit Care Med* 1999;160:2104–2117.
- Arieli R, Van Liew HD. Correction for the response time and delay of mass spectrometers. *J Appl Physiol* 1981;51:1417–1422.
- Belvisi M, Barnes PJ, Larkin S, Yacoub M, Tadjkarimi S, Williams TJ, et al. Nitric oxide synthase activity is elevated in inflammatory lung disease in humans. *Eur J Pharmacol* 1995;283:255–258.
- Blebea J, Bacik B, Strothman G, Myatt L. Decreased nitric oxide production following extremity ischemia and reperfusion. *Am J Surg* 1996;172:158–161.
- Borland C, Cox Y, Higenbottam T. Measurement of exhaled nitric oxide in man. *Thorax* 1993;48:1160–1162.
- Broccard AF, Hotchkiss JR, Suzuki S, Olson D, Marini JJ. Effects of mean airway pressure and tidal excursion on lung injury induced by mechanical ventilation in an isolated perfused rabbit lung model. *Crit Care Med* 1999;27:1533–1541.
- Byrnes CA, Dinarevic S, Busst CA, Shinebourne EA, Bush A. Effect of measurement conditions on measured levels of peak exhaled nitric oxide. *Thorax* 1997;159:697–701.
- Dreyfuss D, Soler P, Saumon G. Mechanical ventilation-induced pulmonary edema. Interaction with previous lung alterations. *Am J Respir Crit Care Med* 1995;151:1568–1575.
- Fernández-Mondéjar E, Hambraeus-Jonzon K, Ronéus A, Hedenstierna G. Nitric oxide increases dramatically in air exhaled from lung regions with occluded vessels. *Acta Anaesthesiol Scand* 2003;47:312–318.
- Fiser WP, Friday CD, Read RC. Changes in arterial oxygenation and pulmonary shunt during thoracotomy with endobronchial anesthesia. *J Thorac Cardiovasc Surg* 1982;83:523–531.
- Gama de Abreu M, Heintz M, Heller A, Széchényi R, Albrecht DM, Koch T. One-lung ventilation with high tidal volumes and zero positive end-expiratory pressure is injurious in the isolated rabbit lung model. *Anesth Analg* 2003;96:220–228.
- Gustafsson LE, Leone AM, Persson MG, Wiklund NP, Moncada S. Endogenous nitric oxide is present in the exhaled air of rabbits, guinea pigs and humans. *Biochem Biophys Res Commun* 1991;181:852–857.
- Hill GE, Ruggeroli A, Pohorecki R, Alonso A, Robbins RA. Cigarette smoking reduces endogenous airway nitric oxide production during cardiopulmonary bypass in humans. *Anesth Analg* 1995;81:170–172.
- Hill GE, Snider S, Galbraith TA, Forst S, Robbins RA. Glucocorticoid reduction of bronchial epithelial inflammation during cardiopulmonary bypass. *Am J Respir Crit Care Med* 1995;152:1791–1795.
- Humpl T, Campbell R, Stephens D, Van Arsdell G, Benson LN, Holtby HM, et al. Levels of exhaled nitric oxide before and after surgical and transcatheter device closure of atrial septal defects in children. *J Thorac Cardiovasc Surg* 2002;124:806–810.
- Ishibe Y, Liu R, Hirose J, Kawamura K, Yamasaki K, Saito N. Exhaled nitric oxide level decreases after cardiopulmonary bypass in adult patients. *Crit Care Med* 2000;28:3823–3827.
- Kharitonov SA, Chung KF, Evans D, O'Connor BJ, Barnes PJ. Increased exhaled nitric oxide in asthma is mainly derived from the lower respiratory tract. *Am J Respir Crit Care Med* 1996;153:1773–1780.
- Kövesi T, Royston D, Yacoub M, Marczin N. Basal and nitroglycerin-induced exhaled nitric oxide before and after cardiac surgery with cardiopulmonary bypass. *Br J Anaesth* 2003;90:608–616.
- Liu R, Ishibe Y, Okazaki N, Kimura K. Chemi-

- luminescence underestimates nitric oxide concentration in the presence of potent inhalation anaesthetics. *Br J Anaesth* 2000;84:596–599.
- 21 Oka T, Ozawa Y, Sato J. Lung collapse during one lung ventilation does not change low frequency respiratory mechanics. *Masui* 1998;47:1427–1432 (in Japanese).
 - 22 Rehder K, Wenthe FM, Sessler AD. Function of each lung during mechanical ventilation with ZEEP and with PEEP in man anesthetized with thiopental-meperidine. *Anesthesiology* 1973;39:597–606.
 - 23 Robbins RA, Floreani AA, Von Essen SG, Sisson JH, Hill GE, Rubinstein I, et al. Measurement of exhaled nitric oxide by three different techniques. *Am J Respir Crit Care Med* 1996;153:1631–1635.
 - 24 Rogers SN, Benumof JL. Halothane and isoflurane do not decrease PaO₂ during one-lung ventilation in intravenously anesthetized patients. *Anesth Analg* 1985;64:946–954.
 - 25 Sartori C, Lepori M, Busch T, Duplain H, Hildebrandt W, Bärtzsch P, et al. Exhaled nitric oxide does not provide a marker of vascular endothelial function in healthy humans. *Am J Respir Crit Care Med* 1999; 160:879–882.
 - 26 Stewart TE, Valenza F, Ribeiro SP, Wener AD, Volgyesi G, Mullen JB, et al. Increased nitric oxide in exhaled gas as an early marker of lung inflammation in a model of sepsis. *Am J Respir Crit Care Med* 1995;151:713–718.
 - 27 Törnberg DC, Bjorne H, Lundberg JO, Weitzberg E. Multiple single breath measurements of nitric oxide in the intubated patient. *Am J Respir Crit Care Med* 2003;168:1210–1215.
 - 28 Wulff KE, Aulin I. The regional lung function in the lateral decubitus position during anesthesia and operation. *Acta Anaesthesiol Scand* 1972;16:195–205.

Received September 29, 2003; accepted November 6, 2003

Corresponding author: Yukari Minami