

Challenges in designing a localisation system suitable for hazardous environments

Tho Nguyen, Aman Kaur and Omar Howlader

The London South Bank Innovation Centre for Automation in NDT, Cambridge

Introduction

The project is part of a 2-year Fast Track to Innovation grant by the European Commission to design and manufacture a localisation/navigation system (both software & hardware) in the context of a robotic platform for petrochemical tank inspection application (oil & gas specific).

The work includes (i) Mechanical design and manufacture, (ii) Electronic design & integration; and (iii) Algorithm development & programming of the localisation system. The procedure follows specific requirements which underpin the ATEX regulations (Europe) and IECEx certification (world-wide).

Challenges break down to (i) short time scale for all tasks to be carried out (ii) specific and strict constraints in deployment of equipment in zoned areas regarding build materials, voltage barrier, etc., (iii) limited availability of off-the-shelf products.

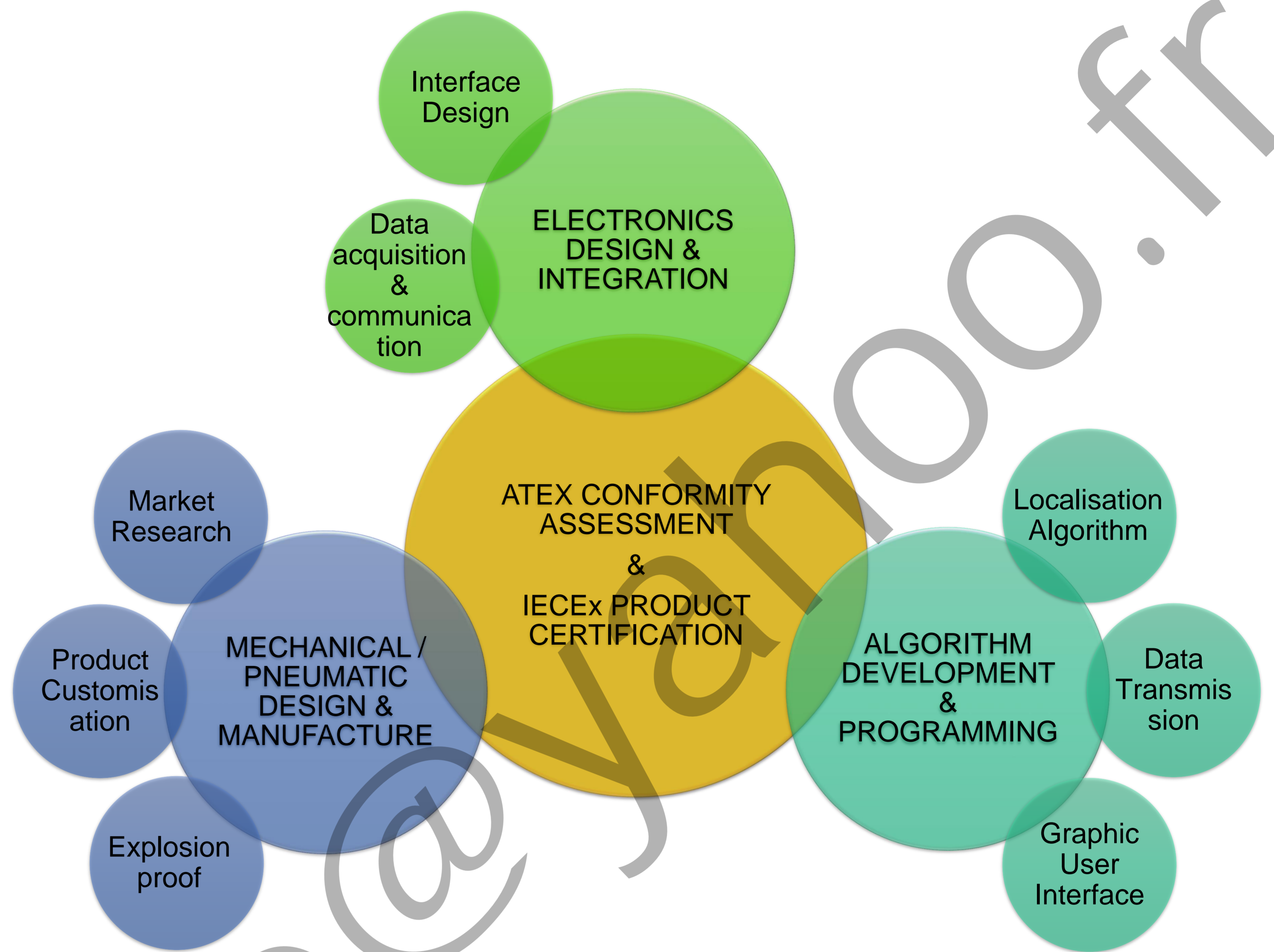

Mechanical Design & Manufacture

The biggest design challenge is its compliance with **Ex ma IIA T3 Ga** (electric) and **Ex h IIA T3 Ga** (non-electric) for corrosive and highly explosive gaseous & liquid-based environment. Standards to follow include and not limited to BS EN ISO 80079-36, 80079-37 and BS EN 60079-18.

Control Electronics Design & Integration

- ❖ Support for multiple interfaces types to integrate with sub-units;
- ❖ Data acquisition of a variety of sensors;
- ❖ Communication with remote control unit through Ethernet;
- ❖ Provision for safety features e.g. thermal trips.

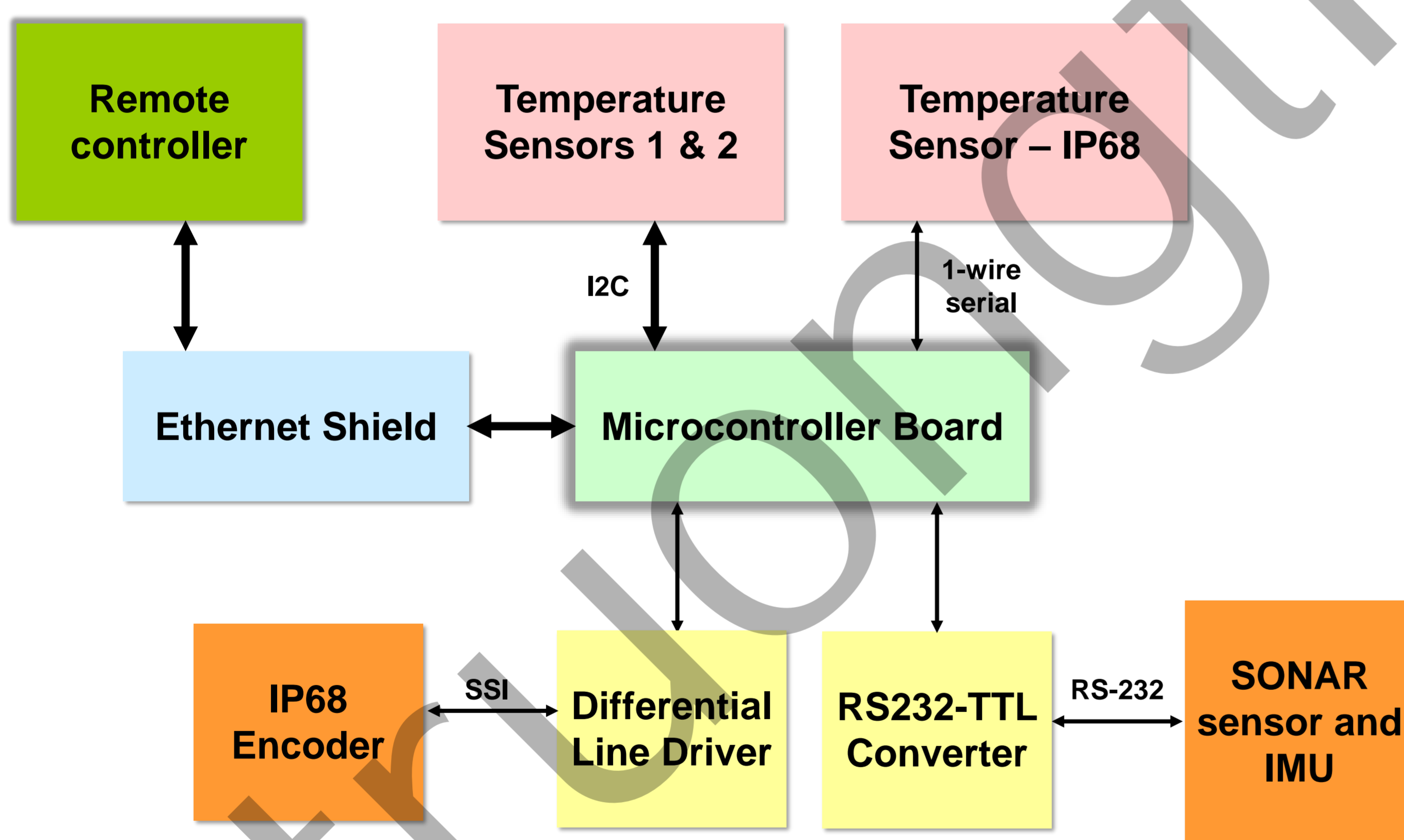

Algorithm Development & Programming

- ❖ Bi-directional communication between the robot and the control panel;
- ❖ Real time monitoring of the robot orientations and thermal profile of the critical areas;
- ❖ 360 degrees mapping and regeneration of the tank inner boundary;
- ❖ Semi-autonomous simultaneous mapping and localisation of the robot inside the tank.

