

Amphibious Robot For Weld Inspection Inside Floating Production Oil Storage Tanks

T.P. Sattar¹, H.E. Leon Rodriguez¹, J. Shang¹, T. Gan² and A. Lagonikas³

¹ Department of Electrical, Computer and Communications Engineering,
London South Bank University, 103 Borough Road, London SE1 0AA

² TWI Ltd, Granta Park, Great Abington, Cambridge CB1 6AL

³ Zenon S.A., 5 Kanari Street, Gl. Nera, GR 15354, Kinari Street, Athens, Greece
email: Sattartp@lsbu.ac.uk, leonrh@lsbu.ac.uk,

Abstract: An amphibious and mobile robotic inspection system is described that has been developed to test welds located inside a floating production storage oil tank (FPSO tank). The robot has been designed to operate both in air and while submerged in oil to test welds on structural strengthening plates and tank walls. It operates in air when the tank has been emptied with only a few inches of product remaining on the floor. In this case the robot moves on the floor of the tank and inspects welds on the bottom of the strengthening plates and the floor. The robot operates in a liquid by swimming down from a manhole in the roof of the tank and settling on the floor in the vicinity of a test area. In both air and liquid, ultrasonic sensors profile the surrounding strengthening plates and tank walls and guide the robot autonomously along the welds. A Cartesian scanning arm mounted on the robot scans the welds with an ACFM probe and performs non-destructive testing (NDT) after the robot has been positioned correctly.

The robot trajectory required to follow the welds precisely in a constrained space requires motion that is straight-line along the welds, 90° rotations of the robot to follow the weld and present the scanner arm correctly when going from a strengthening plate to a side-wall and back onto the next plate. To achieve this motion, special mechanisms have been designed to rotate all four wheels through turning angles between $\pm 180^\circ$ and to independently control all four wheels.

The paper describes and demonstrates the performance of the amphibious inspection robot operating in water and in air. Preliminary NDT results obtained with ultrasonic and ACFM techniques applied to a mock-up of FPSO strengthening plates are presented. The paper discusses features of the design that will enable further development for operation in oil and explosive environments.

Keywords: Swimming Robots, Weld Inspection of FPSO Strengthening Plates, Underwater Wall Climbing Robots, Amphibious Robots

I. INTRODUCTION

The aim of this work is to develop an amphibious and mobile robotic inspection system to test welds located inside a floating production storage oil tank (FPSO tank) [1]. Currently these welds are inspected manually by first emptying and cleaning the tank. This is a time consuming and expensive operation that requires operators to enter a hazardous environment. Significant cost reductions would be made if the inspection could be automated so that the tank is either emptied so that only two to three centimeters of oil remain on the tank floor or preferably if the robot can perform the inspection in a full tank. In the first case the robot would operate in air and an explosive environment but would

eliminate the need to swim the robot through a very complicated maze of partitioning walls and rows of strengthening plates that occur every 700-900 mm. In the second case the robot would swim to a strengthening plate and operate under oil thereby eliminating the need to empty the tank. The FPSO inspection task and suitable Non-destructive Testing methods are reported in [2]. Figure 1 shows two FPSO tanks (yellow area) in the cross-section of a ship hull. The strengthening plates are visible on the floor of each tank.

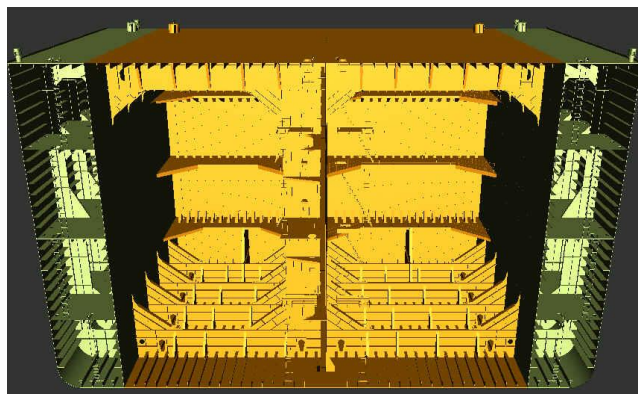

Fig. 1: Cross section of the hull of a ship with two FPSO tanks

II. DESIGN OF AMPHIBIOUS MOBILE ROBOT

A. Design Requirements

The swimming and wall-climbing robot is required to provide access to welds on strengthening plates on the walls and the floors of tank in a very cluttered environment.

It should be compact, mass approximately 20kg, so that it can be inserted through a manhole of minimum diameter 600mm. In FPSO's owned by BP, the manholes are two elliptical hatches into each cargo tank approx. 900x600mm in size. FPSO's operated by Petrobras have approx. 600x800mm openings.

The robot should be transportable by one or at most two operators, and should be able to operate between two adjacent longitudinal strengthening plates separated by a distance of 900 mm with the transverse frames separated by a distance of 4.5m. Both the walls and the floor are cluttered with

strengthening plates so that unhindered robot motion on the walls or the floor by a small robot is not possible.

Access to welds could be obtained by swimming over the plates from one section of the tank to another and then landing on a wall or floor between the plates.

The NDT inspection requirement is to inspect vertical welds as well as horizontal welds.

B. Design for operation in oil

For operation in crude oil and a potentially explosive environment, it is necessary to consider making the robot intrinsically safe.

1) Buoyancy In Water And In Crude Oil

The oil industry uses API gravity as a measure of crude density. This is an inverse measure, the higher the API number, the lower the density.

$$\text{API gravity} = \frac{141.5}{\text{specific gravity at } 60^{\circ} F} - 131.5$$

Where, specific gravity is the ratio of density of oil to density of water.

Light crude oil has a API gravity of more than 40. At API = 40, density of water is 998 kg m^{-3} , the density of light crude is 823.42 kg m^{-3} . (For comparison, the density of paraffin oil is 800 kg m^{-3})

Heavy crude oil, typically API gravity of 20 or less, has a density of 932.13 kg m^{-3} (For comparison, the density of olive oil is 920 kg m^{-3})

A robot designed to be neutrally buoyant in water (with either mass or volume control), will experience a negative buoyancy force in oil.

For example, if the robot weight in air is 998 kg and its volume is 1 m^3 , it will be neutrally buoyant in water and will experience a negative force of 66 kg in heavy crude with API gravity of 20. The same robot in light crude API gravity of 40, will experience a negative buoyancy force of 175 kg.

In conclusion, if sufficient range of mass or volume change is designed into the buoyancy tanks, then the same robot should be able to operate in all types of crude oil.

2) Design for intrinsic safety in explosive environments

To meet BASEEFA requirements for Certification, the following issues were considered:

- All electronics must be in a single enclosure for all electrical/electronic components – sealed and purged with inert gases
- Provide two safety switches in series monitor pressure in enclosure and cut-off power supply at operators station when pressure falls below a threshold value

- There will be a explosion risk in “Vapour” zone when inserting robot into tank. Solution will be to use a purged funnel.
- Use materials that prevent build up of electrical static and avoid sharp corners where a discharge could occur.

C. Final Design of Robot

The final design of the robot is shown in figures 2 and 3. This design is a further development of a wall climbing robot called RobTank that has been developed earlier for in-service inspection of oil and chemical storage tanks [3]. The wall-climbing ability of this robot has been tested and demonstrated in water tanks. It can make transitions from a floor to a wall and vice-versa.

Further development of this design has added a variable buoyancy tank that can quickly and accurately control buoyancy around the neutral buoyancy of the robot.

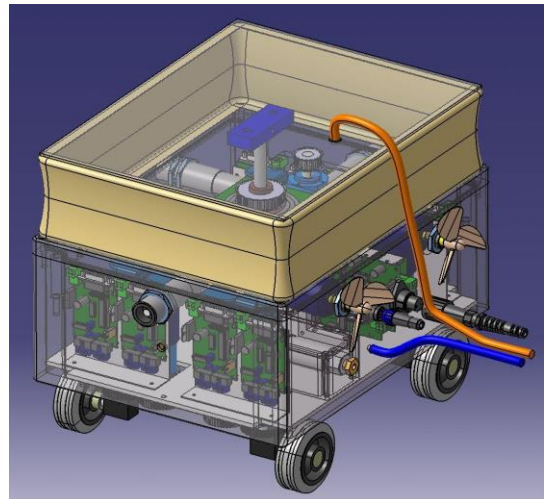

Fig. 2: Amphibious mobile robot showing the variable buoyancy tank on top of the sealed chamber housing the servo drive systems

All control systems are embedded on-board the robot in a gas pressurized central chamber sealed to prevent the ingress of water through any leaks at the rotating shafts emerging from the central chamber and through NDT sensor probe cables. The reason for placing most hardware systems onboard the robot is to reduce the size of the umbilical cord so that cable management becomes easier.

The outer dimensions of the robot are (mm): 410L x 300W x 300H. Its mass in air is 12 kg and it can carry a payload of 8kg.

On-board embedded servo controllers with encoder feedback control the speed and position of the robot. High level control is from an operators console via RS 485 twin pair communications with on-board controllers.

Both depth and horizontal motion is controlled simultaneously to swim the robot to a test site on a wall or above a floor area that is to be tested.

Scanning Arm mounted on this face

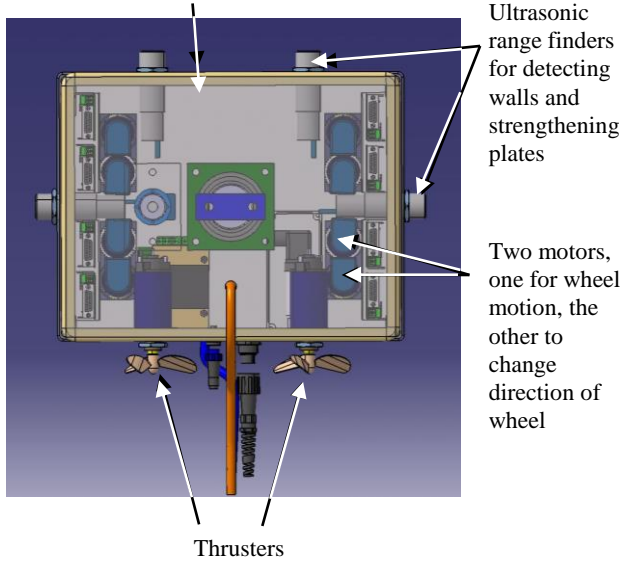

Fig. 3: Plan view of the robot showing location of ultrasonic range sensors and the six drive motors and two thruster motors

After insertion of the robot through a manhole in the top deck, positive or negative buoyancy control is used to swim the robot vertically to a specified depth and to maintain that depth with neutral buoyancy. Two independent, speed controlled thrusters move the robot in a horizontal plane in the forward and reverse direction or rotate it to face in any direction.

The robot is designed to operate in air as well as submerged in water (at this stage) though eventually it will be made intrinsically safe to operate in crude oil (API 20 to 40). It consists of a buoyancy tank on top that adjusts its buoyancy around neutral by controlling its mass. A depth sensor provides the feedback to regulate the depth at which the robot is required to maintain its position.

A system of four ultrasonic sensors operating at 10 KHz and a rotating ultrasonic sensor at 5 MHz profile the surrounding strengthening plates and tank walls. These sensors are used to align the robot and to guide it autonomously along welds between the floor and strengthening plates and the toe ends of the plates. The Cartesian scanner shown in figure 4 carrying an ACFM probe scans the welds after the robot has been positioned correctly.

Robot trajectory in a constrained space for precise weld following around plates and side walls requires motion that is straight-line along welds, 90° rotation to present the scanner arm correctly when going from a plate to a side-wall and back onto the next plate. Special mechanisms have been designed to rotate all four wheels through turning angles between $\pm 180^\circ$ and to independently control the speeds of all four wheels.

III. SCANNING ARM

The robot is required to follow weld lines, stopping to deploy NDT probes with a scanning arm.

The mechanical scanning arm selected to be used for carrying and deploying each NDT sensor at the desired location, is depicted in figure 4.

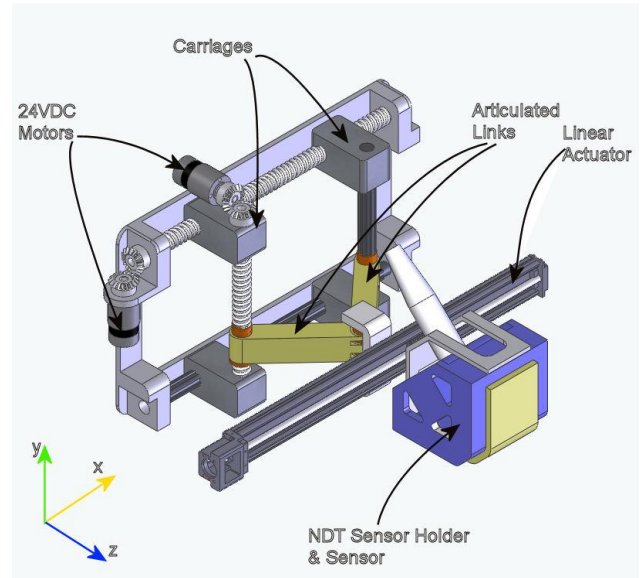

Fig. 4: Mechanical Scanner Design

Figure 5 shows the robot with a scanning arm fitted to one of the faces. The robot is shown between two strengthening plates (stiffeners) and the side wall of a tank. The NDT sensor shown is an ACFM probe.

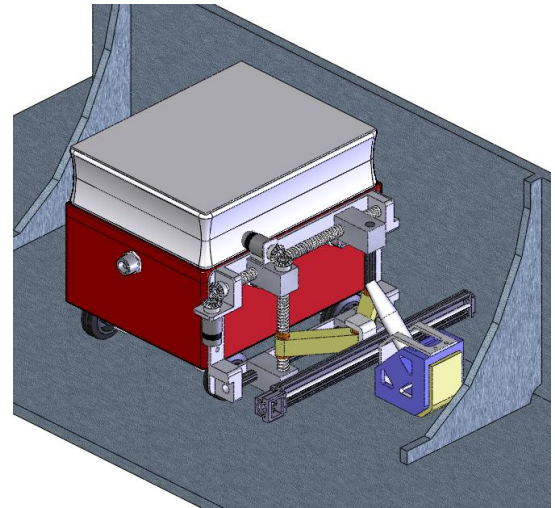

Fig. 5: Scanner mounted on front face of robot, shown deploying an ACFM NDT probe while located between two stiffener plates in a FPSO tank

The arm consists of two sets of 12mm diameter threaded shaft mechanisms, paired with guide shafts and their respective motor modules.

A horizontal threaded shaft and its dedicated motor module are mounted onto a back plate, which connects the scanner to the robotic platform. By setting the motor accordingly, the threaded shaft mechanism is able to provide the carriages with linear actuation along the X axis.

The carriage itself comprises of a vertical shaft and a linear guide shaft jointed with articulated links to a linear guide

actuator, which in turn is connected to the sensor holder that carries the sensor of each respective NDT method. The actuation provided by the motor module which is mounted onto the back plate, allows the carriage to move the threaded shaft and the guide shaft mechanism in opposite directions, thus moving inwards or outwards allowing actuation for the NDT sensor holder along the Z axis.

Motion along the Y Axis is achieved by the actuation of the vertical threaded shaft.

Finally, the linear actuator which is placed between the articulated links and the sensor holder drives the sensors along the X axis.

The scanning arm's modular configuration allows the sensor holder and thus the sensors to move along three degrees of freedom, so they can be placed safely and accurately into position in order to carry out the inspection of the welding. The retractable feature of the scanner arm contributes to the compact build of the overall system so it can be inserted easily into the inspection area and maintains its manoeuvrability by keeping the centre of mass close to the robot. When expanded, the sensor's tip can reach up to 350mm in front of the robotic platform and with a linear guide actuator of 400mm in operational length, the sensor can inspect hardly accessible corners of the tank's structure. The bearing load that the arm can hold may reach up to 4Kg , depending on the NDT method used at that time, which at this expanded position, will result to a required torque of 8Nm that the 24VDC motors are able to safely sustain.

The linear displacement of each module is measured by the encoders which are embedded into the 24V DC motor arrangements. Due to the harsh environment under which the system is subjected to operate, delicate in construction components like the motor controller, motor drives and various custom electronics are shielded in to an IP68 enclosure inside the robotic platform's casing. The linear guide actuator is composed of a one-piece outer rail surrounding an inner block, a ball screw drive through the block's centre, and two linear motion guide raceways per each side of the block, that overall provide for a rigid actuator function and positional accuracy in the order of tenths of a millimetre.

In order to avoid potential undesired contact with an object, robot's scanner must be able to map the space axially in front and on the side of the scanner is necessary. For the completion of this objective, 4 distance-measuring sensors are to be integrated on the sensor holder. The readings from these sensors as the scanner holder extends and retracts, will assist the robot's overall behavior while inspecting.

IV. FOLLOWING MOTION TRAJECTORIES

The robot is required to follow strengthening plate welds by keeping the scanning arm parallel to a plate and rotating itself through ninety degrees after it has reached the tank wall. The space between two strengthening plate is very constrained so that large turning circles are not possible. The required trajectory is shown in figure 6.

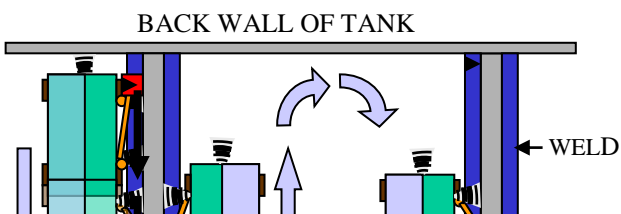

Fig. 6: Robot trajectory between two adjacent strengthening plates

This trajectory is possible provided the four wheels can be turned through any angle between zero and ninety. A special mechanism actuated by two motors has been developed to permit this turning. Four mechanisms are required, one for each wheel.

Two ultrasonic range finders are mounted on the front face of the robot. The scanning arm is mounted on this face.

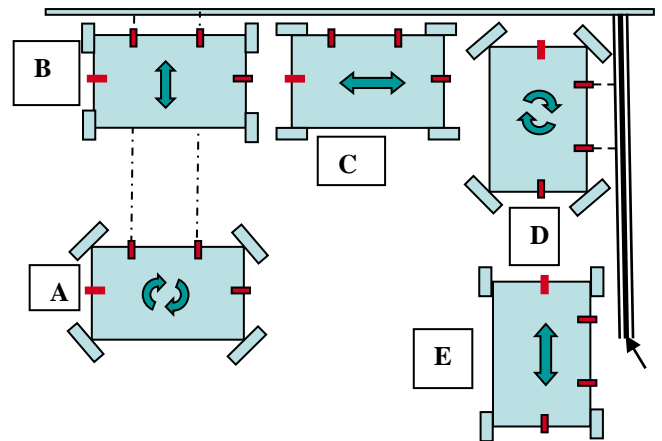

Fig. 7: Sensor guided straight-line and Rotation motion of robot to follow back wall and plate welds

The trajectory that shows the principle of operation in figure 7 starts in position A. The robot can be rotated at the same position coordinates by turning all wheels to be at a pre-computed angle. The distance measured by each sensor is equalized by rotating anti/clockwise. The wheels are turned to face the wall as in position B and the robot moved towards the tank wall till it is at a required distance. The robot then moves along the wall towards the strengthening (stiffener) plate, maintaining the required distance, position C. When the side range sensor detects the strengthening plate, the robot is rotated to face the plate, as shown in position D. The robot then aligns itself to be parallel and at a desired distance from the plate. The wheels are turned as in position E and the robot

moves along the plate, inspecting the weld with the scanning arm.

A block diagram of the control system is shown in figure 8.

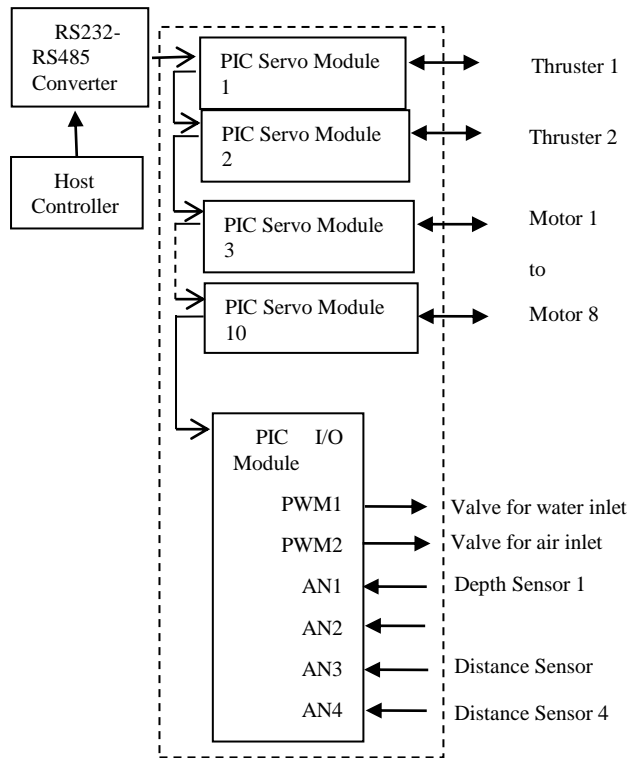

Fig. 8: Block diagram of control system for robot vehicle

V. TESTS OF ROBOT MOTION WHEN OPERATING IN AIR

The vehicle platform shown in figure 9 has been developed to test the motion of the robot when following a trajectory along stiffener welds.

The mechanisms to rotate the robot at the same spot to find a stiffener or wall and then adjust the robot position to be normal to the wall have worked as expected.

A limitation is the range of the ultrasonic sensors which work reliably up to 1.5 metres when the orientation angle of the robot is less than fifteen degrees.

The robot is able to autonomously follow the weld along the stiffener plates and the side walls of the FPSO tank while maintaining the correct distance from the wall and stiffener plates.

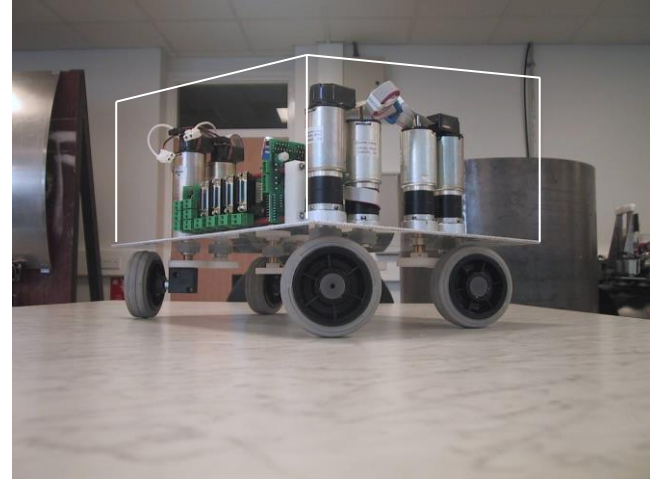

Fig. 9: Platform to test robot motion and trajectory following capability

VI. NDT TECHNIQUES FOR FPSO INSPECTION

In this experiment, an ultrasonic creep wave probe has been used to measure weld on a stiffener plate.

The experimental setup is shown in figure 10. The creep wave probe consisting of dual crystal with an angle 25° at 4MHz was used. The choice of the frequency is related to the range of the inspection. Creep waves appear when the longitudinal wave is propagating at an angle greater than 75° but less than 90° . The optimum angle for a strong creep wave signal had to be determined within this range. In this application, the optimum value was found at a refracted angle of 80° . It has enough cover range to make it possible to inspect both fillet welds in the stiffener plate to the T-joint from the other side.

In the case of the ACFM sensor, a 50kHz corrosion probe was used. The coils used to generate Eddy-current field in the test surface are placed either side of the test area. Their position will determine the direction of current flow, which must be across the cracks if the perturbations in the field are to be at a maximum. Sensor coils used in conventional eddy-current testing can be absolute (a simple single coil) or differential (a coil split into oppositely wound halves). In this experiment, the probe has a diameter of 50mm and provides B_x and B_z responses from defect depth. B_x and B_z corresponds to the field in the horizontal and vertical directions. (Note: B_x is perpendicular to the current and parallel to the surface of the test sample, and the B_z is perpendicular to the surface of the test sample. For deployment on fatigue cracked weld toes for example where a crack is parallel to the weld, the x-direction will be parallel to the crack edge) [4]

Finally, since the sensitivity of the technique is also dependent on the area sensed by the coil, the smaller the area, the higher the sensitivity, the pairs of coils were arranged in arrays, that gave coverage of the whole weld surface.

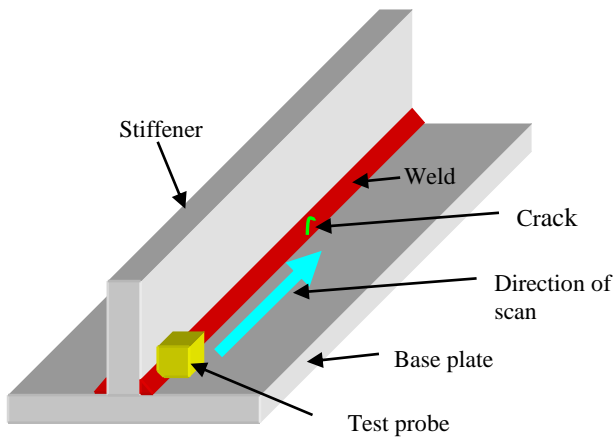

Fig. 10: Experimental setup for data collection using ACFM and ultrasonic creep wave probes.

A. Results and discussion

Figure 11 shows the A-scan results from the ultrasonic creep probe measurements with the defects at the beginning and end of the weld.

The figure also shows that the background noise is relatively high compared to the received signal.

Due to this reason, determination of the defect size is difficult. The scan was then repeated using the ACFM probe.

Examples of the ACFM waveforms are shown in Figures 12 and 13. These figures illustrate the Bx and Bz data of defects at the beginning and end of weld. Both ACFM and ultrasonics data are well correlated, indicating the position of the defects.

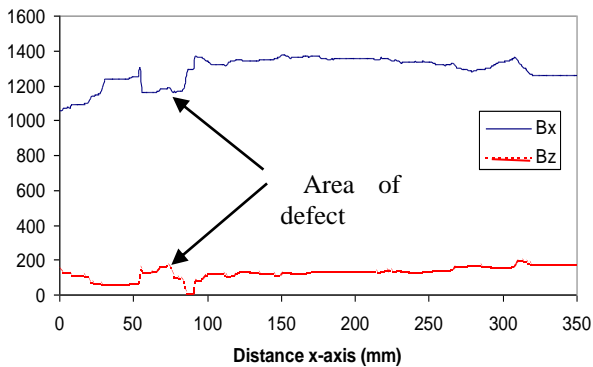

Fig. 12: An example of the ACFM data illustrating the Bx and Bz data of defect at the beginning of the weld.

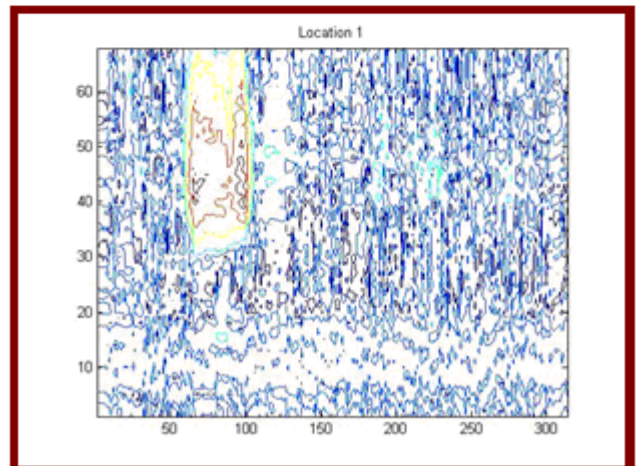
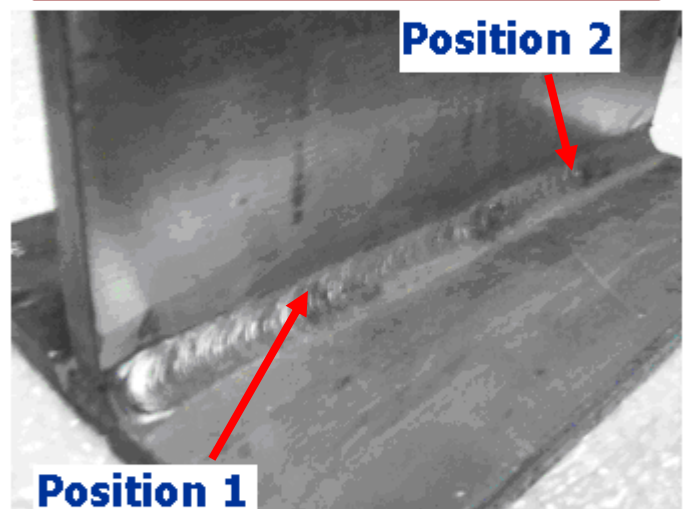
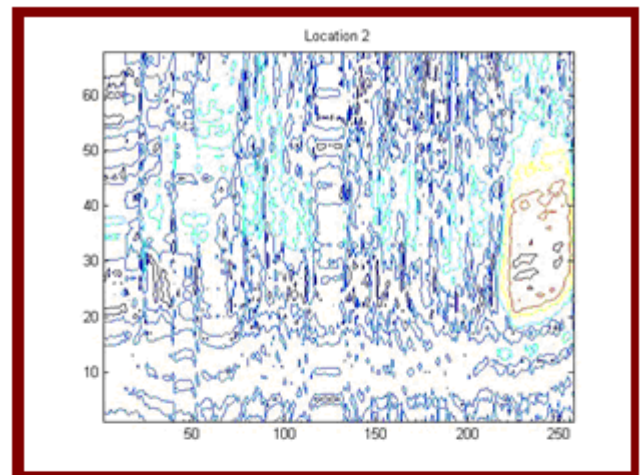

Fig. 11: A-scan results from ultrasonic creep. (Position1) defect at the beginning of the weld and (Position 2) defect at the end of the weld.

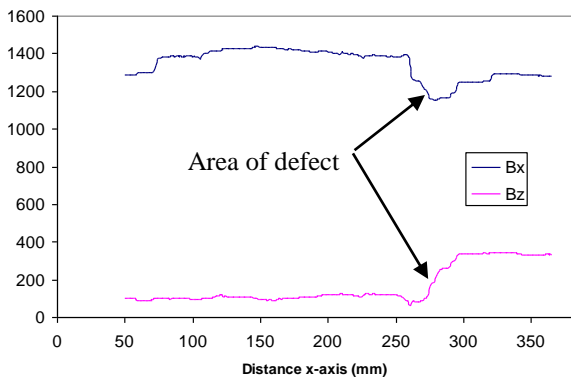

Fig. 13: An example of the ACFM data illustrating the Bx and Bz data of defect at the end of the weld.

VII. PROFILING SURROUNDING PLATES WITH A ULTRASONIC RADAR

Experiments have been conducted to develop a ultrasonic pulse echo radar that will enable the robot to detect the presence and distance of stiffener plates in a dark medium such as crude oil. This radar will be in addition to the four ultrasonic range finders mounted on the front and sides of the robot. The ultrasonic probe/ mirror arrangement shown in figure 14 was rotated by $\pm 60^\circ$ starting from the corner of two plates at right angles to each other. A C-scan image displays the detected plates and the corner where the two plates join. A grid of points was created where the probe was positioned.

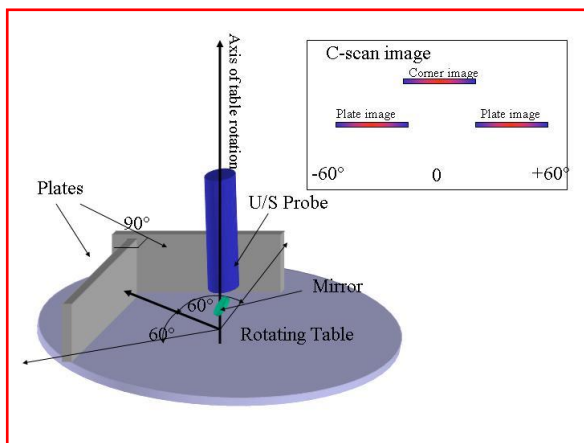

Fig 14: Ultrasonic radar probe setup to detect plates

Figure 15 shows the grid and the starting co-ordinate 0, 0 with the normal to one plate being the x-axis and the normal to the other plate being the y-axis.

The distance of each plate from the 0,0 co-ordinate was $x = 127.28$ mm and $y = 127.28$ mm.

The c-scan image obtained by first looking at the corner and then rotating the table by $\pm 60^\circ$ is shown in figure 16.

An algorithm has been developed to compute plate distances from the c-scan data. The measured values for co-ordinate

position 0,0 were $x = 126.25$ and $y = 130.46$, giving measurement errors of 1.03 and -2.18 mm respectively. Measurements were repeated with the probe at other grid points. The measurement errors were within ± 4 mm, giving sufficient resolution to enable accurate profiling of the surrounding plates and other objects.

Fig. 15: Co-ordinate positions for the ultrasonic probe to

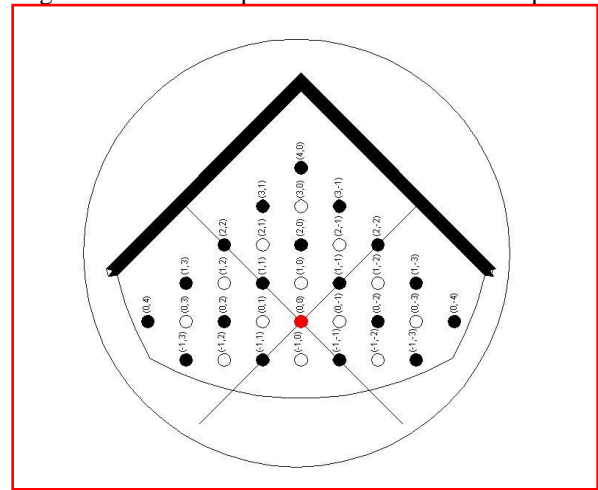

measure plate distances

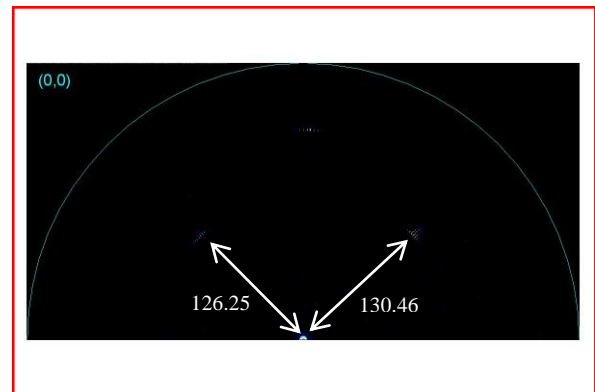

Fig 16: C-scan image showing detection of the corner and plate sides from 0,0 co-ordinate position

Further work is being done to select a suitable probe frequency to give optimum results in oil and to develop the real-time computational algorithm to profile the objects and plates surrounding the robot.

VIII. CONCLUSION AND FUTURE WORK

Prototype robot modules have been built and tested. The robot is able to locate stiffener plates and tank walls with its ultrasonic sensors. It is then able to follow welds on the floor while operating in air (emptied tank). The ACFM NDT technique has been tested on weld samples. Other NDT techniques (conventional ultrasonic, ultrasonic phased array, and plate waves) have been tested but are not reported here. The scanning arm has been built and tested but not integrated with the robot vehicle yet. The swimming and depth regulation capability of the variable buoyancy tank has been tested and reported in [5]. Full integration of all modules and data fusion

of NDT has commenced and is expected to be completed in the next four months.

ACKNOWLEDGEMENTS

This work is funded by the European Community through the CRAFT project FPSO INSPECT (COOP-2004-508599) [1] with the following partnership: NDT Consultant (UK), TSC Inspection Systems (UK), Isotest Engineering (Italy), Tecnitest Ingenieros (Spain), Spree Engineering Ltd (UK), Miltech Hellas S.A. (Greece), ZENON (Greece), Kingston Computer Consultancy (UK), BP (UK), Petrobras (Brazil) and LondonSouth Bank University (UK). The Project is coordinated and managed by TWI (UK).

The Nueva Granada Military University of Colombia, sponsors the Ph.D studies of H.E. Leon Rodriguez.

The ACFM NDT results are the work of TWI Ltd, Cambridge (UK) and the results from experiments on ultrasonic radar are the work of Isotest Engineering, Italy.

REFERENCES

- [1] European CRAFT project FPSO-INSPECT, *Non-Intrusive In-Service Inspection Robot for Condition Monitoring of Welds Inside Floating Production Storage and Off-loading (FPSO) Vessels*, 6th Framework Programme RTDD-CRAFT Proposal ref 508599
- [2] T.P. Sattar, Leon H. Rodriguez, J. Shang, *Automated NDT Of Floating Production Storage Oil Tanks With A Swimming And Climbing Robot*, in Proceedings of the 8th International Conference on Climbing and Walking Robots and the Support Technologies for Mobile Machines (CLAWAR 2005), Editors Tokhi, Virk and Hossain, ISBN-10 3-540-26413-2, Springer, ISBN-13 978-3-540-26413-2, pp. 935-942
- [3] Sattar T.P., Zhao Z., Feng J., Bridge B., Mondal S., Chen S., (2002) *Internal In-service Inspection of the floor and walls of Oil, Petroleum and Chemical Storage Tanks with a Mobile Robot*, Proc. Of 5th International Conference on Climbing and Walking Robots and the Support Technologies for Mobile Machines, Edited by Philippe Bidaud and Faiz Ben Amar, ISBN 1 86058 380 6, 2002, pp 947-954, Professional Engineering Publishing Ltd. UK.
- [4] <http://www.tscinspectionssystem.co.uk/indexACFM.htm?http://www.tscinspectionssystem.co.uk/ACFMDetailPg1.htm>
- [5] Shang,J., Sattar, T.P., Leon Rodriguez , H.E, *PDA Depth Control of a FPSO Swimming Robot*, Proceedings of the 9th International Conference on Climbing and Walking Robots and the Support Technologies for Mobile Machines (CLAWAR 2006), to appear