

Design of Pellet Recycle Scraper System in Sand-Blasting Chamber

Wang Baoli

Bombardier Sifang (Qingdao)
Transportation Ltd
Shandong 266111, China

Wang Junli

Bombardier Sifang (Qingdao)
Transportation Ltd
Shandong 266111, China

Zhao Zhipeng

Bombardier Sifang (Qingdao)
Transportation Ltd
Shandong 266111, China
e-mail: 760907040@qq.com

Abstract—In the process of industrial sand-blasting, it is necessary to recycle the pellet. In order to solve the existing problems such as high cost, vulnerability, maintenance difficulty and low recycle efficiency in pneumatic recycling system and mechanical recycling system of pellet, we designed a trapezoidal scraper recycle system of pellet which powered by the cylinder and controlled by PLC to realize the pellet collection. The core component of the system is the scraper mechanical structure which mainly composed of scraper, scraper cylinder, baffle, scraper frame, bearing. This design has the advantages such as simple structure, resistant to breakdown, easy dismantlement. By installing pneumatic valve on the cylinder, the sand scraping speed can be adjusted. The trapezoidal scraper pellet recycling system efficiency is much higher after the contrast experiments between trapezoidal scraper and mechanical screw conveyor of the original equipment.

Keywords-Pellet; Cylinder; PLC; Scraper; Trapezoid

I. INTRODUCTION

In order to improve the adhesion of the surface paint, it is necessary to sand-blast on the workpiece. During the sand-blasting process, pellet need to be recycled for the purpose of cost reduction [1-2]. At present, pneumatic recycling system [3] and mechanical recycling system [4-5] are widely used in our country for pellet recycle. However, problems such as high cost, vulnerability and maintenance difficulty still exist. Therefore, it is overwhelming important to design a recycle system for pellet of low cost, resistance to breakdown and easy maintenance.

II. PELLET RECYCLE SYSTEM

Scraper-typed pellet recycle system [6] designed by this design is mainly composed of 2 rod, 3 scraper, 5 cylinder, 6 pellet-collect container and so on. As shown in Figure 1, 1 is trench, 4 is air rod and 7 is pellet material. The air rod is fixedly connected with the pull rod. Numerous scrapers with the same structure are fixedly connected with the pull rod. The scraper has the function of one-way reversing. When the air rod is retracted, the scraper will move the pellet material

to the material collecting container. When the air rod is stretched out, the scraper will flip without pushing pellet, so that pellet will achieve a cycle of directional movement. By installing pneumatic valve on the cylinder, air rod speed can be adjusted.

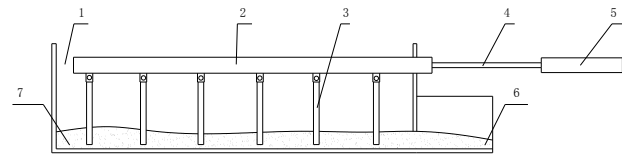

Figure 1. Scraper pellet recycle system

III. MECHANICAL SYSTEM DESIGN

A. Scraper structure

The core component of the material recycle system is the scraper. For the scraper system designed in this design as shown in Fig. 2, Fig. 3, Fig. 4, Fig. 5, 1 is trench, 7 is the pellet material. The physical map is shown in Figure 3-4. Scraper system is mainly composed of 2 bearing mounting plates, 3 scraper frame, 4 vertical bearing, 5 lateral bearing, 6 scraper, 8 baffle, 9 bayonet and 10 scraper cylinder as shown in Figure 3-1 and Figure 3-2. Scraper and scraper cylinder are in dynamic connection, with functions such as one-way flip and reverse scraping. The basic scraper structure is trapezoidal. The role of bayonet is to constrain the freedom for scraper up and down. The surface of the scraper frame is fixedly connected with the scraper cylinder and the baffle. Lateral bearing and vertical bearing are cross-typed with functions of guiding and undertaking weight respectively as shown in Figure 3-3. Lateral bearing and vertical bearing are mounted on the bearing mounting plate. Bearing mounting plate is fixedly installed on the inner wall of the trench. One end of the scraper frame is fixedly connected with the air rod. The pneumatic control valves and proximity switch are mounted onto the air cylinder.

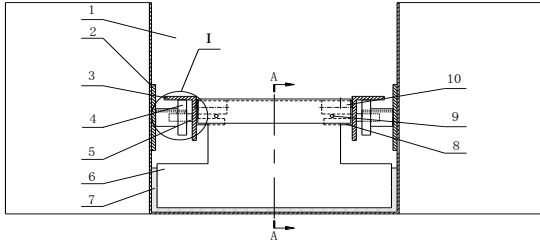

Figure 2. Scraper system

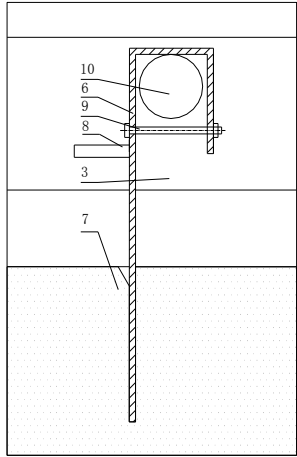

Figure 3. A-A directional view

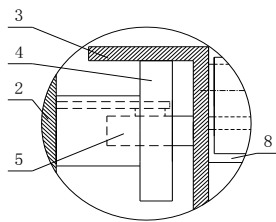

Figure 4. I partial view



Figure 5. Physical map of trapezoidal scraper

B. Scraper's working theory

Once the scraper-typed pellet recycle is started, the scraper frame will move the trapezoid scraper forward and

backward by scraper cylinder. When the scraper moves forward, the scraper will push the pellet forward due to the pulling force of the air cylinder and the blocking effect of the baffle up on the scraper. When the scraper moves backward, the baffle won't have blocking effect on the scraper, the scraper rotates around the scraper cylinder under the reaction force of the pellet on the ground, it won't push the pellet material. With such a reciprocating rhyme, directional movement of pellet material can be completed as well as pellet will be collected. Pneumatic valve can adjust the air rod running speed according to the current situation, hence adjust the scraping pellet speed by scraper.

C. Scraper performance analysis

- The scraper major components are cylinder, scraper, scraper frame, bearing and so on. It has advantages such as simple structure, low cost, easy dismantlement.
- This design uses trapezoidal scraper and make full use of the trench surface to supervise the height of pellet piled in case it affects scraper flip. Its influence is most obvious when the width of trench is small.
- The bearings are distant from the ground, which can prevent the accumulation of pellet from damaging the bearings to reduce the maintenance times.
- The pneumatic speed control valve is installed onto the cylinder so the scraper speed can be reduced when there are fewer pellet, which can reduce scraper loss.

IV. ELECTRICAL SYSTEM DESIGN

According to requirements of the system, this design uses Siemens S7-200 PLC to control the scraper. This product is cheap, powerful with great practicality. PLC I/O allocation table is shown in Table 1. Its external wiring diagram is shown in Fig 6. Proximate to the switch, PLC detects the position of the air rod and controls direction change of the cylinder through solenoid valve. When the air rod fails to change direction, the PLC will stop and give alarms [7-8].

TABLE I. PLC I/O ALLOCATION

Input		Output	
Input component	Address	Output component	Address
SB1, start	I0	Y1, cylinder out	Q0
SB2, stop	I1	Y2, cylinder contraction	Q1
SQ1, cylinder stretched out until the position of test	I2	BJ1, warning light	Q2
SQ2, cylinder contracted until the position of test	I3		

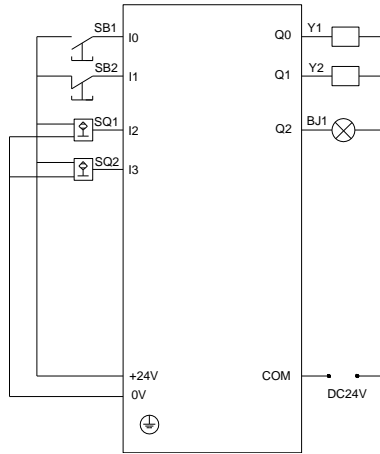

Figure 6. Schema of electrical control

V. EFFICIENCY COMPARISON BETWEEN TRAPEZOIDAL SCRAPER AND MECHANICAL PELLET RECYCLE SYSTEM

In this design, trapezoidal scraper and the original mechanical screw conveyor pellet recycling efficiencies are compared. The same amount of pellet are placed in two ditches. With both systems under the best operating efficiency, statistics of recycle time will be collected according to 5 kg, 10 kg and 15 kg pellet. The result is shown in Table 2.

TABLE II. PELLET RECOVERY TIME

Recycled pellet quality (kg)	Pellet recovery time(hour)	
	Screw conveyor	Trapezoidal scraper
5	0.51	0.30
10	1.11	0.62
15	1.56	0.89

Data show that under the same condition, the time required to complete the 5 kg, 10 kg, 15 kg recycle by trapezoidal scraper is significantly less than that of the mechanical screw conveyor thus prove that the trapezoidal scraper pellet recycle system efficiency is much higher.

VI. CONCLUSION

Scraped pellet recycle system is proposed in this design. It uses Siemens S7-200 PLC as the controller and its core component is the trapezoidal scraper whose advantages are simple structure, resistance to breakdown and easy dismantlement. With comparison of experiments, it shows high efficiency in recycling pellet. Hence it is worthwhile of popularization.

REFERENCES

- [1] Ye Yangxiang, Pan zhaoji. Application Manual for Coating Technology [M]. China Machine Press, 1997.
- [2] Yao Shoushan, Li Geyang, Hu wenbing. Surface Science and Technology [M]. China Machine Press, 2005.
- [3] Wang Xuefang. Analysis of Pneumatic Sand-Blasting System [J].Electric Power Locomotives and Urban Railway Vehicles, 2003, 26 (2): 30-32.
- [4] Wang Yongli. Application Examples by Sand-Blasting Machine in the Coating Line [J]. Modern Coatings, 2013, 16 (3): 27-33.
- [5] Liu Fugui. Research on Screw Conveyor Machine of Pellet [J]. Rolling Stock Workers, 2001 (11): 9-11.
- [6] Luan Xianyu, Liu Hongnan. Design of Blasting Chamber Scraper Recycle System Based on PLC [J]. Mechanical Engineers, 2014 (6): 158-159
- [7] Liu Huabo. Siemens S7-200 PLC programming and application case selection [M]. China Machine Press, 2009.
- [8] Liao Changchu. S7-200 PLC programming and application [M]. China Machine Press, 2014