



OPTIMIZATION OF MODIFIED ROTAMETER USING HALL PROBE SENSOR WITH RESPECT TO LIQUID DENSITY AND ITS CALIBRATION USING ARTIFICIAL NEURAL NETWORK

Sunita Sinha and Nirupama Mandal, *MIEEE*

Department of Electronics Engineering, Indian Institute of Technology (ISM) Dhanbad, India

Emails: nirupama_cal@rediffmail.com, sunita07ecmjpru@gmail.com

Submitted: Oct. 3, 2016

Accepted: Nov. 12, 2016

Published: Dec. 1, 2016

Abstract- Rotameter is one of the most commonly used local indicating type flow measuring instrument. For remote indication and control a secondary transducer like Hall Probe sensor, LVDT etc. is incorporated with the conventional rotameter. In this paper, a modified rotameter with Hall Probe sensor is used as a measuring instrument. The output hall voltage is proportional to the flow rate of the fluid and the change in fluid density may also vary the hall voltage. So this kind of variation shows incorrect flow rate if the density of the float is not taken to a very high value compared to the density of the fluid. But the density float may affect the flow rate measurement and introduce error. In this respect firstly the variation of Hall voltage with respect to liquid density is analyzed and then the measuring system is calibrated using ANN. The ANN calculates the correction factor with respect to the change in liquid density, which results in obtaining the output close to the desired output. The simulation results show that the calibration technique is efficient.

Index terms: Flow rate, Hall Probe sensor, rotameter, Artificial Neural Network, Correction factor, Accuracy.

I. INTRODUCTION

Rotameter is popular as one of the industrial flowmeter because of its linear scale, large measurement range, constant and low pressure drop. Also rotameters simplicity of installation and maintenance has enhanced its usage in various process and control industries. The measurement of flow [1-6] is based on the position of float which changes with change in flow rate. The factory calibrated rotameters can be used for a particular liquid under a specific temperature and pressure conditions. For varying liquid, temperature and pressure conditions the device need to be recalibrated to maintain accuracy in measurement. Rotameters are usually calibrated for water as process fluid. Variations in viscosity (5 to 20 centistokes) of the liquid do not affect the actual flow rate in large extent. But with the variation of liquid density, actual flow rate varies and it will result in error in measurement. So the measurement needs to be corrected. Correction factor increases the accuracy of the system.

Thomas Povey *et al.* [13] proposed and demonstrated a new technique for measuring mass flow rate accurately without using calibrated flowmeters for gases exiting from an initially pressurized plenum. Rogie I. Rodriguez *et al.* [18] designed a wireless inductive-capacitive (L-C) sensor which can be used for monitoring temperatures in rotating components like power plants and jet planes. Nasrin Afsarimanes *et al.* [19] gave a calibration method using LabVIEW software for characterizing and optimizing thermal sensors like thermistors and RTD. Zhang Haining *et al.* [24] gave an algorithm for temperature–pressure compensation using two-phase flow for vortex flowmeter. This method can be used in petroleum and chemical industries where the input that is crude oil contains a mixture of gases. In conventional rotameter the reading of the rotameter cannot be sent at remote location. So to remove this drawback, we need to convert the float movement obtained at a particular flow rate to the corresponding output in the form of electrical signal. For this we need to modify the conventional rotameter. Some researchers have worked towards this field. K.Chakraborty *et al.* [20] proposed a modified rotameter so that the output from rotameter can be transmitted to remote location. N. Mandal *et al.* [25] have used improved inductance bridge–type technique to design a modified rotameter transmitter. The proposed method consist of a very thin wire made up of ferromagnetic material is attached with the float. When there is change in the flow rate then the wire with the float moves up and down. Since the other end of wire is free so it will also move up and down. The inductive coils mounted on the

rotameter senses movement of free end of wire. The self-inductance variation was converted into electrical energy and using modified inductance bridge network that electrical energy is converted into DC current signal which can be sending to remote indicator using signal conditioner. Since the rotameter suffers from the problem of transmission of measurement value from field location to the control area. So by using hall probe based technique, the float movement can be converted into electrical current signal which can be transmitted to remote area. Hall probe sensor has different applications in the field of measurement. V.N. Petousis *et al.* [14, 16] presented a new hall sensor which works on the novel concept of offset reduction method. By using this method, the electric field variation inside the hall effect sensor caused by external magnetic field can be controlled. The combination of this method and dynamic spinning current method with elaborate sequence produces a hall voltage with less noise even if external magnetic field are present. H.T Dearden [23] presented a method to calculate uncertainty in a flow total. The given approach can be used for compensating variations of various process variables like pressure and density. S.Sinha *et al.* [27] designed, developed and tested a non-contact type modified rotameter with hall probe sensor. A circular permanent magnet was attached to the float and a hall probe sensor was placed outside the rotameter at the axial point to sense the change in magnetic field with the change in float position. The drawbacks of conventional LVDT type and inductance type rotameter transducer was removed by using hall probe sensor. But the main drawback of this type modified rotameter flow transmitter is the calibration difficulties due to change in density of liquid as well as temperature. This limitation can be eliminated by Artificial Neural Network. Many researchers have worked for the improvement in the performance of the measurement system and controlling the process. A.A.Aldair *et al.*[17] designed an intelligent controller using neuro-fuzzy technique for non-linear active suspension systems in vehicle. This artificial intelligence based controller can handle non-linearities in less time as compared to conventional controller. Jianming Liu [21] proposed a concrete filled core steel tube. The Radial Basis function of Artificial Neural Network is used for calculating the loading capacity of concrete filled core steel tube. Xing Haihua *et al.* [26] proposed a sensitivity analysis method using hierarchical hybrid fuzzy neural network. The relationship between input and output values can be determined by using this sensitivity analysis method. Also the important input data can be identified by using this method. This method can be used for both continuous and discrete input values. Researchers have

removed the drawbacks in flow measurement system by calibrating the measurement system using Artificial Neural Network. Haizhuang Kang *et al.* [7] have optimized the location of sensor for measuring flue gas flow in industrial ducts and stacks with the help of neural network. T.T.Yeh *et al.* [8] have worked towards the development of intelligent ultrasonic flow measurement technique using Artificial Neural Network. They used pattern recognition method for flow field detection. In field applications, the proposed advanced ultrasonic flowmeters are beneficial. C.Ronette *et al.*[9] have reviewed mostly used neural network based methods for modeling of a system mainly in field of bio-chemical engineering. They discussed the mostly used architectures including black box neural networks and hybrid neural networks which are used for modeling bio-chemical and chemical processes. The discussed architecture include multilayer perceptron and Radial Basis function categorized under static neural networks and under dynamic neural networks delayed input feed forward neural network, elman neural network and neural space model are categorized. The neural network architectures are widely used for complex non-linear modeling and control of chemical and bio- chemical processes. S.Gh. Etemad *et al.* [10] calculated correction factor of pitot tube for both purely viscous newtonian and non-newtonian fluids using simulations on galerkin finite elements. R.A. Hooshmand *et al.* [11] have designed and optimized the electromagnetic flowmeter. They also calibrated the flowmeter using neural network. By using neural network the correction factor was calculated with respect to the variation in liquid level and conductivity coefficient. The calculation of correction factors lead to the increase of system accuracy. Lei Shi *et al.* [12] have done the nonlinear calibration of pH sensor using neural network. Bo-Kaixia *et al.* [15] gave a solution for measuring the water content in oil using genetic algorithm and Radial Basis function neural network based hybrid model. The non-linear mapping property of ANN was used for this purpose. Huichao Zhao *et al.* [22] have proposed the integration of data in multipath ultrasonic flowmeter using Artificial Neural Network. They obtained the training and testing data from CFD simulations. A three layer feed forward neural network was used. By calibrating the system with neural network, the flexibility of the system to work under complex flow profiles was increased. Shaojiang Dong *et al.* [28] proposed a new method based on back propagation neural network and support vector machine model to identify the rotating machine fault. The validation of the proposed method was done in real world with vibration monitoring data.

From the aforesaid work done by various researchers, we analyzed that by calibrating the system with Artificial Neural Network, the problem of non-linearity can be removed and also the system accuracy can be increased to a greater extent. In the present paper, we have proposed a calibration technique using Artificial Neural Network. Since the output hall voltage varies with the change in input parameters like liquid density and temperature so to avoid this variation in hall voltage the modified rotameter is calibrated using Artificial Neural Network. In this paper, firstly it is shown that how the actual flow rate varies with change of liquid density and then the correction factor is calculated using artificial neural network.

II. THEORY

2.1 Relation between output hall voltage and Density

In the modified rotameter with hall probe sensor [27] shown in Figure 1, a circular permanent magnet is attached with the float so that with the change in position of float the magnet position also changes. This results in increase in magnetic field intensity with increase in flow rate at the axial point of the ring magnet.

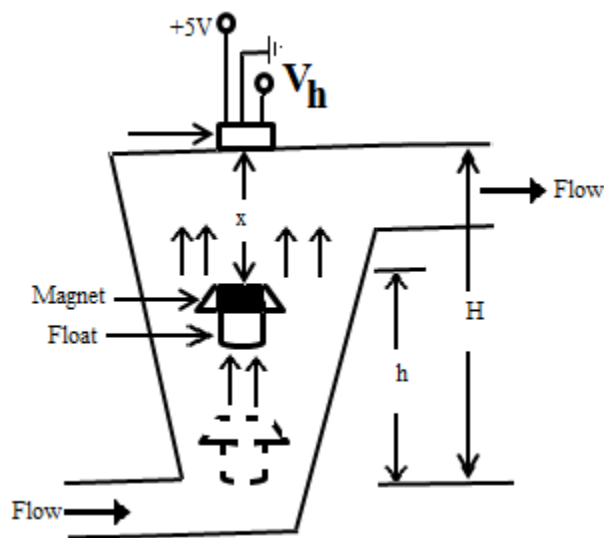

Figure 1. Modified Rotameter with Hall Probe Sensor

When the float is a height h then the flow rate Q is given by,

$$Q \propto \sqrt{\frac{\rho_F - \rho_L}{\rho_L} h} \quad (1)$$

where ρ_F and ρ_L are density of float and liquid respectively. If ρ_F is greater than ρ_L then

$$Q \propto \sqrt{\frac{\rho_F}{\rho_L} h}. \quad (2)$$

where

Q = Flow rate

ρ_F = Float density

ρ_L = Liquid density

Now, for some limiting value of 'x', the axial magnetic field B_x follows inverse square root relation and is given by,

$$B_x = \frac{k_1}{x^2} \quad (3)$$

where k_1 is a constant. Also rotameter principle states that the flow rate ' Q ' is directly proportional to float height ' h '.

$$\text{Hence } Q = k_2 h. \quad (4)$$

where k_2 is constant. When constant current flows through the sensor then the hall voltage, v_h is proportional to the axial magnetic field, B_x and is given by,

$$v_h = k_3 B_x. \quad (5)$$

where k_3 is a constant. From equation (2) we have,

$$h_1 \propto \sqrt{\frac{\rho_L}{\rho_F}} \quad (6)$$

If ρ_F is constant then $h_1 \propto \sqrt{\rho_L}$.

$$\text{So, } h_1 = k_4 \sqrt{\rho_L} \quad (7)$$

where k_4 is a constant. Now the distance of hall probe from float is given by,

$$x = H - h_1 = H - k_4 \sqrt{\rho_L} \quad (8)$$

From equations (3) and (5) we have,

$$v_h = k_3 \frac{k_1}{x^2} \quad (9)$$

From equations (8) and (9) we get,

$$v_h = k_3 \frac{k_1}{(H - k_4 \sqrt{\rho_L})^2} \quad (10)$$

From equation (10) we have,

$$v_h = \frac{k_1 k_3}{H^2 \left(1 - \frac{K_4}{H} \sqrt{\rho_L}\right)^2} \quad (11)$$

or,
$$v_h = \frac{k_1 k_3}{H^2} \left(1 - \frac{K_4}{H} \sqrt{\rho_L}\right)^{-2} \quad (12)$$

Using binomial expansion and simplification we get,

$$v_h = \frac{k_5}{H^2} \left(1 + \frac{2K_4}{H} \sqrt{\rho_L}\right) \quad (13)$$

Hence the equation (13) shows the relationship between the hall voltage and the liquid density. By placing the values of the constant and assuming the value of 'H' equal to 25cm, the variation in hall voltage with respect to liquid density can be observed.

2.2. Calculation of correction factor

Rotameter is one of the most efficient and economical flowmeters. According to the need it can be designed to resist high pressures, high temperatures and corrosive fluids. Also the factors affecting electronic meters do not affect measurement of rotameter. Generally flowmeters are calibrated for some common fluids. Similarly, the calibration of rotameter is usually done with water for liquid. The calibration factor or curve tells how volumetric flow rate and float position (i.e. height) are related to each other for a particular float and tapered tube. For liquids other than water the new corrected volumetric flow rate should be calculated. Normally the calibration of rotameter for water is done with a specific gravity of 1.0 and viscosity with 1.0 centistokes. The actual flow rate with respect to calibrated value does not change significantly with the variation in viscosity in the range 5 centistokes to 20 centistokes. But when there is variation in density and temperature the actual flow rate will change. Therefore for liquids other than water the correction factor must be calculated.

The volumetric flow rate of rotameter for water at height 'h₁' is given by,

$$Q_w = k_3 \sqrt{\frac{\rho_f - \rho_w}{\rho_w}} h_1 \quad (14)$$

where Q_w is the calibrated flow rate for water. In same rotameter if a liquid other than water flows then the flow rate is adjusted till the float reach the same height. In this case the flow rate is given by,

$$Q_l = k_3 \sqrt{\frac{\rho_f - \rho_l}{\rho_l}} h_1 \quad (15)$$

where Q_l is the actual flow rate.

From equations (14) and (15) we get,

$$\frac{Q_l}{Q_w} = \sqrt{\frac{(\rho_f - \rho_l)\rho_w}{(\rho_f - \rho_w)\rho_l}} \quad (16)$$

The above equation represents the corrected flow rate or correction factor. Since in modified rotameter the float is of stainless steel so $\rho_f = 8.02 \text{ g/cm}^3$ and $\rho_w = 1.0 \text{ g/cm}^3$. So the correction factor is given by,

$$C.F = \sqrt{\frac{(8.02 - \rho_l)}{7.02\rho_l}} \quad (17)$$

The correction factor can be calculated from neural network and the corrected output can be obtained after calibration. The block diagram of the proposed calibration is shown in following Figure 2.

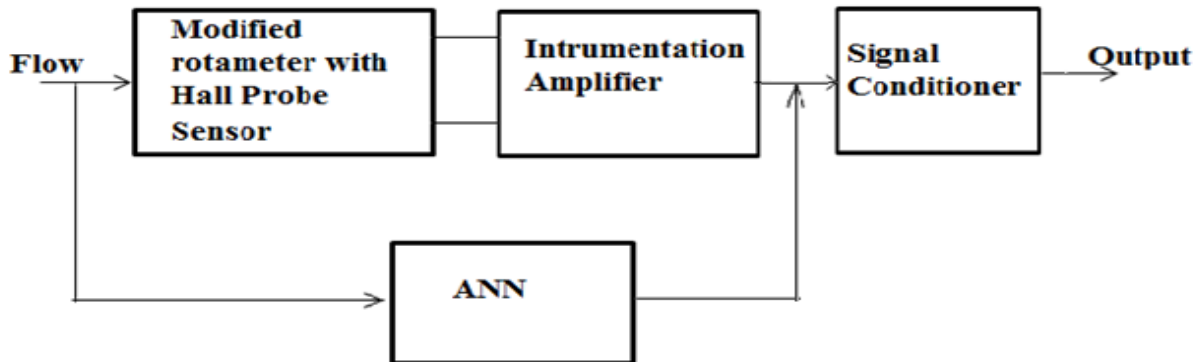

Figure 2. Block diagram of the proposed measurement system

2.3. Calculation of correction factor using neural networks

For designing Artificial Neural Network sampling, training and testing are done. The range of liquid density considered for training Artificial Neural Network is 0.955 g/cm^3 to 1 g/cm^3 . The liquid density is randomly divided into 30 parts. After training the Artificial Neural Network, the testing is done with different values of liquid density as input.

III. RESULT AND SIMULATIONS

Experiments are done using different industrial fluid with different density. Initially the modified rotameter was calibrated for water. Then for different liquids, the output of the hall voltage is taken maintaining a constant flow rate. When different liquids were used as process fluid in the modified rotameter then the hall sensor voltage varied with the change in liquid density. The hall voltage output is plotted against the density of the liquid. The curve is shown in Figure 3.

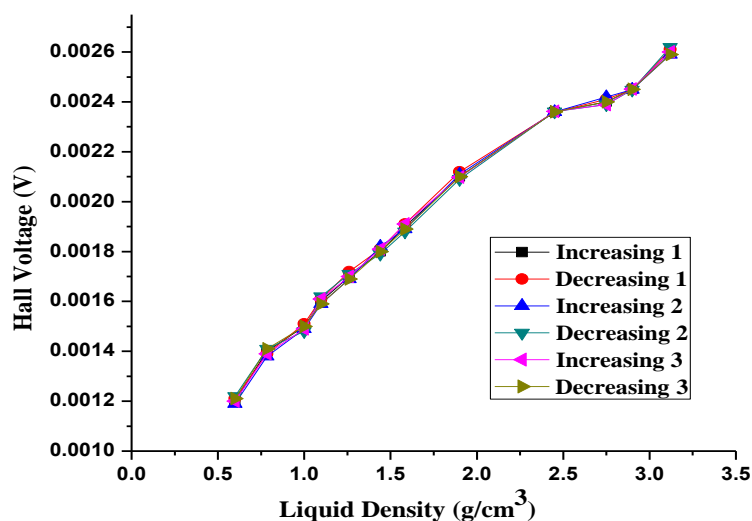

Figure 3. Variation of Hall voltage with liquid density.

The experiment was repeated six times at a constant flow rate of 12 LPM and the standard deviation curve for six observations at different values of liquid density is shown in Figure 4.

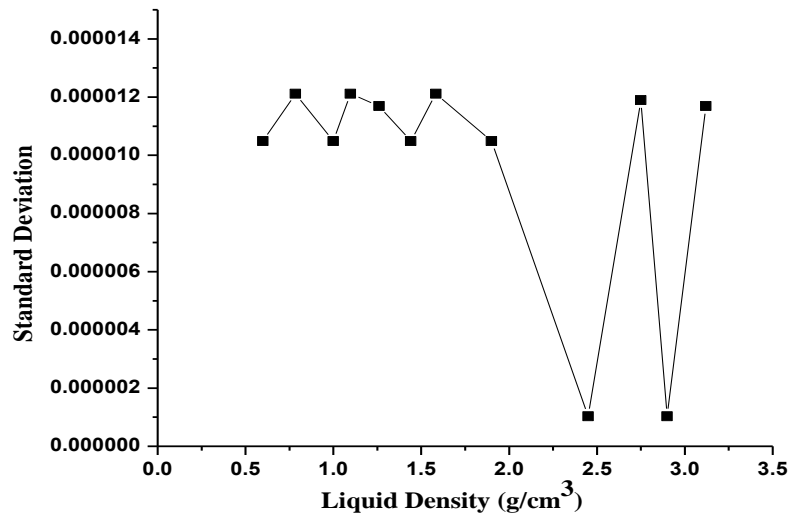

Figure 4. Standard deviation curve

After training the Network performance function, mean square error is obtained. In the current training MSE is obtained at epoch 98. Mean square error shows the network performance according to the mean of the squared errors. For all data sets the mean square error dynamics comes in logarithmic scale and as decreasing function.

The mean square error plot is given in Figure 5, after training the Artificial Neural Network.

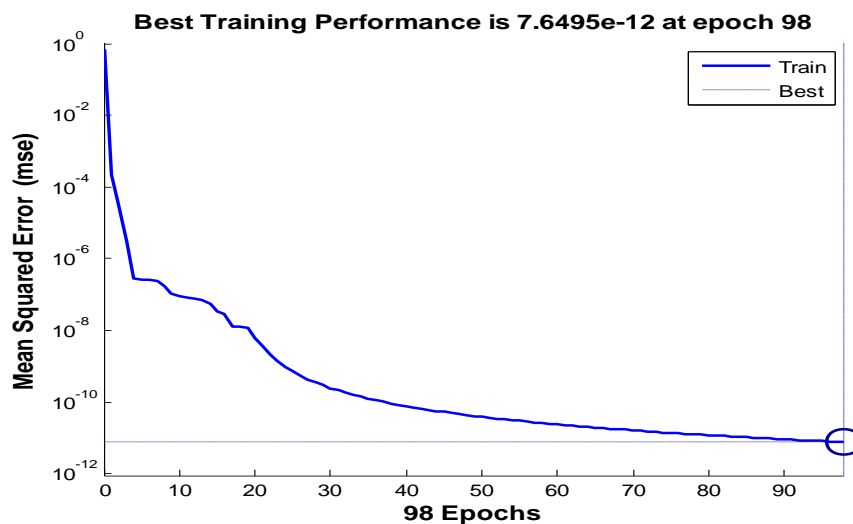

Figure 5. MSE Plot

The statistics can be analyzed from training state. The gradient in the plot shows the back propagation gradient in logarithmic scales on each iteration. Validation fails shows the iterations

when MSE increased its value. After six fails in a row Matlab automatically stops. The training state plot is given in Figure 6.

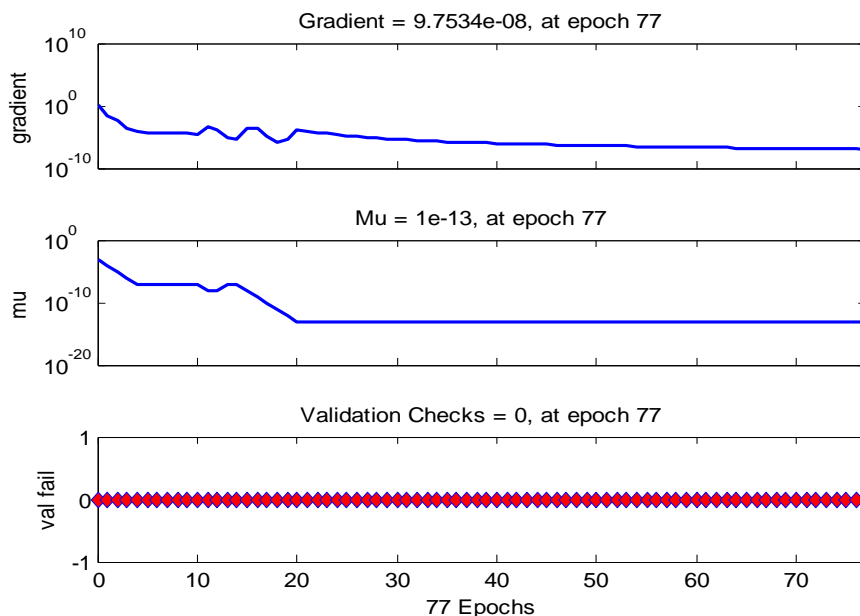

Figure 6. Training State Plot

After training the ANN, it was tested for various values of liquid density. As seen from the table 1 there is not much difference between the ANN output and the real output. The maximum relative percentage error obtained is 1.97%. The values less than 8 is considered for testing since assumption has been made that the float density is much greater than liquid density and in this experiment the float is made up of stainless steel with its density of 8.02g/cm^3 .

Testing results

Table 1: Simulation results for the testing values of liquid density

Liquid Density	ANN Output	Real Output	Relative Error (%)
0.599	0.8114	0.7957	1.97
0.7846	0.9037	0.8993	0.49
1	1	1	0
1.097	1.0333	1.0401	0.65

1.261	1.0982	1.1019	0.34
1.44	1.1494	1.1618	1.07
1.584	1.1839	1.2051	1.76
1.9	1.29	1.287	0.233
2.45	1.385	1.3943	0.667
2.75	1.44	1.4368	.223
2.90	1.446	1.4543	0.571
3.120	1.4593	1.4793	1.11

The output from ANN was taken repeatedly and the standard deviation calculated for six repeated readings is shown in figure 7. The percentage deviation curve from real output is shown in Figure 8.

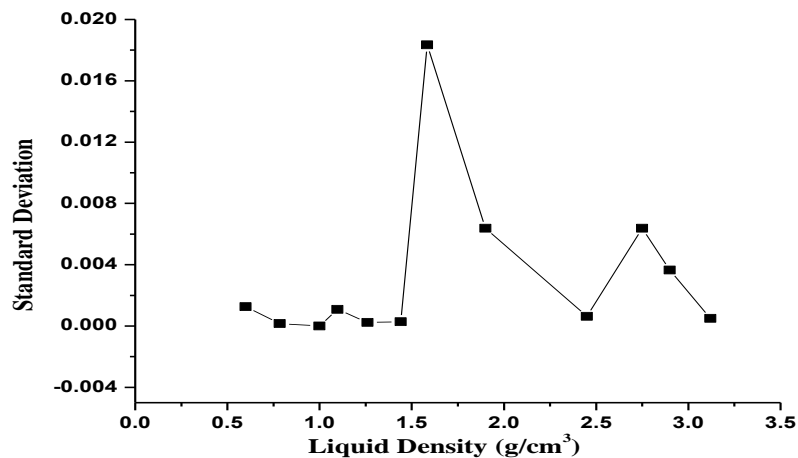

Figure 7. Standard Deviation Curve for ANN Output

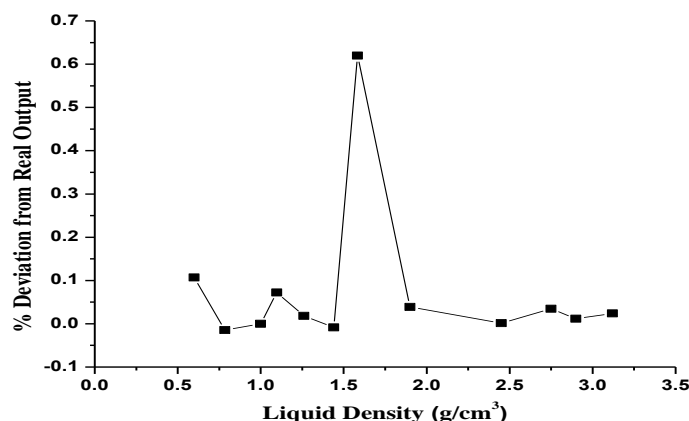

Figure 8. Percentage Deviation Curve for Real Output

The calculated correction factor is the multiplication factor at the output of the rotameter and the error introduced due to variation of liquid density at the input of the fluid of the rotameter is minimized by calibrating the system using Back Propagation Algorithm of Artificial Neural Network. From the testing results, it is observed that the maximum relative error is 1.97%. So the accuracy of the system is increased and recalibration of the measurement system with the variation of input parameters can be avoided by using this ANN based measurement technique.

IV. CONCLUSIONS

In this paper, the effect of change of liquid density on hall voltage in modified rotameter is shown. By applying correction factor as multiplication factor to the measured quantity the effect of change of liquid density and other parameters like temperature can be compensated. A minimum error of $7.6495e-12$ is obtained at an epoch 98 as shown in MSE Plot of performance graph. This results in high level of accuracy. So by calibrating the rotameter with artificial neural network the correction factor was calculated in more accurate form. It is observed from the testing results shown in table 1 that the output from ANN is very near to real output and the relative error obtained lies within $\pm 2\%$. So by calibrating the measurement system by Artificial Neural Network the system is made more accurate and also the non-linearity in input and output relation due to various input parameters like temperature can be removed by ANN based measurement technique.

REFERENCES

- 1) E.O. Doebelin, Measurement system and design, 4th ed. New York: Mc Graw – Hill , 1990.
- 2) P.Bentley, principles of measurement systems, 3rd ed. Singapore: Longman Singapore publishers Ltd. 1995.
- 3) K. Gurney, An introduction to neural networks, UCL Press , 1997.
- 4) B.G. Liptak, Process measurement and analysis, 3rd ed. Oxford, U K: Butterworth heinman, 1999.
- 5) B. Yegnanarayana, Artificial neural networks, 11th ed. PHI, 2005.
- 6) K. Suzuki, “Artificial neural networks- industrial and control engineering applications”, INTECH open access publisher, 2011.
- 7) H. Kang, Q.Yang, C.Butler, and Fi Benati, “Optimization of sensor locations for measurement of flue gas flow in industrial ducts and stacks using neural networks”, IEEE Trans. on Instrum. and Meas., vol. 49, no.2, pp. 288-233, April 2000.
- 8) T.T. Yeh, P.I. Espina and A.Stephen Osella, “An intelligent ultrasonic flow meter for improved flow measurement and flow calibration facility”, IEEE Instrum. and Meas. Conf., pp. 1741-1746, May 2001.
- 9) C. Renotte, A. Vande Wouwer, Ph. Bogaertst and M. Remy, “Neural network applications in non-linear modelling of (bio)chemical processes”, Measurement + Control, vol. 34, pp.197-201, Sept. 2001.
- 10) S.G. Etemad, J. Thibault, and S.H. Hashemabadi, “Calculation of the Pitot tube correction factor for Newtonian and Non-Newtonian fluids,” ISA Trans., vol. 42, no.4, pp. 505-512, Oct. 2003.
- 11) R. A. Hooshmand and M. Joorabian, “Design and optimization of electromagnetic flowmeter for conductive liquids and its calibration based on neural networks,” IEE Proc.on Science, Measurement and Technology, vol. 153, no. 4, pp.139-146, July 2006.
- 12) Lei Shi, Li Cai, Zize Liang, and Zengguang Hou, “Nonlinear Calibration of pH Sensor Based on the Back-Propagation Neural Network,” IEEE Conference on Networking, Sensing and Control, pp. 1300-1304, 2008.
- 13) T. Povey and P. F. Beard, “A novel experimental technique for accurate mass flow rate measurement”, Elsevier, Flow Meas. and Instrum. vol. 19, no. 5, pp. 251-259, Oct. 2008.
- 14) V.N. Petoussis, P. D. Dimitropoulos, and G. Stamoulis, “ A novel Hall effect sensor using elaborate offset cancellation method,” Sensors and Transducers J., vol. 100, no. 1, pp. 85-91, Jan. 2009.
- 15) Bo-Kai Xia and Ying-chun Bo, “A soft sensor for water content-in-oil based on GA-RBF neural network” Measurement + Control, vol. 43/6, pp. 179-182, July 2010.
- 16) V.N. Petoussis, P. D. Dimitropoulos, and G. Stamoulis, “General development of a new Hall effect sensor,” Sensors Transducers J., vol. 127, no. 4, pp. 36-44, Apr. 2011.
- 17) A. A. Aldair and W.J. Wang, “Design an intelligent controller for full vehicle nonlinearActive suspension systems”, International journal on smart sensing and intelligentsystems, vol. 4, no. 2, pp. 224- 243, June 2011.
- 18) R.I. Rodriguez and Yi Jia, “A wireless inductive-capacitive (L-C) Sensor for rotating component temperature monitoring”, International journal on smart sensing and intelligent systems, vol. 2, no. 2, pp. 325-337, June 2011.

- 19) Nasrin Afsarimanesh and Pathan Zaher Ahmed, "LabVIEW based characterization and optimization of thermal sensors", International journal on smart sensing and intelligent systems, vol. 4, no. 4, pp.726-739, Dec. 2011.
- 20) K. Chakraborty, N. Mandal, and R. Sarkar, "Design of an electronic flow transmitter using LVDT & hall sensor," Int. J. Electron. Commun. Technol., vol. 4, no. 1, pp. 180-182, 2013.
- 21) Jianmingliu, "Neural networks method applied to the property study of steel-concrete Composite columns under axial compression", International journal on smart sensing and intelligent systems, vol. 6, no. 2, pp. - 548-566, April 2013.
- 22) Huichao Zhao, Lihui Peng, Tsuyoshi Takahashi, Takuya Hayashi, Kazuyoshi Shimizu, and Toshihiro Yamamoto, "ANN based Data Integration for Multi-path Ultrasonic Flowmeter," IEEE Sensors journal, vol.14, no.2, pp. 362-370, Feb. 2014.
- 23) Harvey T Dearden, "Uncertainty in Flow Totals," Measurement and Control, vol. 47. no. 5, pp. 158-160, June 2014.
- 24) Zhang Haining and Ren Yonghui, "Frequency processing and Temperature-pressure compensation of the vortex flow meter based on two phase", International journal on smart sensing and intelligent systems, vol. 7, no. 3, pp. 1326-1346, Sept. 2014.
- 25) N. Mandal, B. Kumar, R. Sarkar, and S.C. Bera, "Design of an flow transmitter using an improved inductance bridge network and rotameter as sensor," IEEE Trans. on Instrum. Meas., vol. 63, no. 12, pp. 3127-3136, Dec. 2014.
- 26) Xing Haihua, Yu Xianchuan, Hu Dan and Dai Sha, "Sensitivity analysis of hierarchical hybrid fuzzy- neural network", International journal on smart sensing and intelligent systems, vol. 8, no. 3, pp. 1837-1854, Sept. 2015.
- 27) S. Sinha, D. Banerjee, N. Mandal, R. Sarkar, and S.C. Bera, " Design and implementation of real-time flow measurement system using hall probe sensor and PC based SCADA," IEEE Sensors Journal, vol. 15, no. 10, pp. 5592-5600, Oct. 2015
- 28) Shaojiang Dong, Xiangyang Xu, Juan Liu and Zhengyuan Gao, "Rotating Machine Fault Diagnosis Based on Locality Preserving Projection and Back Propagation Neural Network-Support Vector Machine Model" Measurement and Control, vol. 48(7), pp. 211-216, 2015.