



## THE IMPLEMENTATION OF HIGH EFFICIENCY WIRELESS SENSOR IN ACOUSTIC OBJECT TRACKING

ChengFang Zhen,<sup>1,3</sup> Wenyi, LIU<sup>2</sup>, and Hanming WEI,<sup>2</sup>

1 School of 1The College of the Computer and Automatic technology, North University of  
China, TaiYuan 030051, PR China

2 Key Laboratory of Instrumentation Science & Dynamic Measurement, North University of  
China, Ministry of Education, TaiYuan 030051, PR China

3 Dept. of computer Science, The University of Alabama, Tuscaloosa, 35401, USA

Emails: [czhen@crimson.ua.edu](mailto:czhen@crimson.ua.edu), [Liuwenyi@nuc.edu.cn](mailto:Liuwenyi@nuc.edu.cn), [Wei1001@163.com](mailto:Wei1001@163.com)

---

*Submitted: Aug. 11, 2015*

*Accepted: Nov. 3, 2015*

*Published: Dec. 1, 2015*

---

*Abstract- Energy control in Wireless Sensor Network is one of the most crucial technologies. Based on the acoustic object localization background, we designed a new structure of the sensor node to realize the energy efficiency in the power supply and artificial sleeping scheduling in this paper. The power control model is independent with data processing and control model and can separately realize the power supply for different part of the node. The node can transfer status according the different circumstance to minimize the energy consumption. Furthermore, a new synchronous sleeping/wake schedule mechanism in the medium access control layer is proposed. Sensor nodes can use the forwarding and listening status to schedule their better energy status on demanded. The experiment has been evaluated and analyzed in a test-bed. The result confirms the structure and the proposed mechanism are energy efficiency and gain better trade-off between the accuracy and efficiency.*

**Index terms:** Wireless sensor network, scalable architecture, energy-equalize, power control.

## I. INTRODUCTION

The latest advances in distributed computing and micro electro mechanical systems(MEMS) have enabled the emergence of a variety of wireless sensor networks (WSNs) applications in the past years, such as comprising military<sup>[1]</sup>,home automation, smart building, healthy and medical application, vehicle and target tracking<sup>[5]</sup>,and industry domains<sup>[6,7]</sup>. The WSNs for detection, localization and tracking of the acoustic sources are widely applicable in industry, defense, robotics and security<sup>[3]</sup>. The common character in these applications is the limited energy for the node because of the deployment with the limited battery power. Moreover, the replacement or supplement of the power are very difficult for the environmental constrains and other factors. All applications are interested in long WSN lifetime. <sup>[2, 4]</sup> The challenge and the motivation of increasing the network lifetime while ensuring a deterministic latency and accuracy is crucial for all the WSN researchers. By increasing the network lifetime and providing a means to ensure the sensed data latency and localization accuracy, we proposed a design and implementation of a WSN node and the energy efficiency in the MAC layer.

In general, a WSN tracking system consists of a large number of low cost and densely deployed battery powered sensor nodes <sup>[6]</sup>.The sensor nodes equipped with wireless communication, sensing, processing and storage functions to monitor a certain phenomenon such as environmental data or object tracking<sup>[8]</sup>.An important characteristic of sensor devices is that their battery capacity is very small, much smaller than conventional wireless devices like laptops and even PDAs, thereby making energy conservation one of the most important issues in sensor network. As the sensor nodes are powered by batteries, it is difficult to replace or recharge because of cost (e.g., cost of battery and labor) or geographic (e.g., difficult or unfriendly terrain) reasons, thus the nodes in WSNs are characterized by limited power, processing, and memory resources which made the energy saving becoming a paramount concern in WSNs. The sensor node should be designed follows: a) power controllable; b) energy efficient; c) high synchronization accuracy. Some WSNs were developed for general applications in decades as follow.

At Berkeley, the Smart Dust project <sup>[9]</sup>, which aims at the develop sensor node of micrometric size. Their focus is on miniaturization of sensor node so that it has a dust size. Since this is a long time project, the first step was the development of the Mote's family. The WeC Mote was one of

the first types of sensor node developed in this project. Then, they upgrade to Mica Mote and finally to Mica2 Mote. The designer claims that the advantage of this last mote is its radio, which is more robust (CCIOOO) compare to TR1000.

The Pico Radio project<sup>[10]</sup> at Berkeley Wireless Research Center is another project at Berkeley. The objective is to develop a low-cost and low-power sensor node. Its focus is at the radio hardware, link and network layer stack. Medusa Mk-2<sup>[11]</sup> and iBadge<sup>[12]</sup> are sensor nodes from UCLA. These sensor nodes use more than one processor and iBagde also includes a Bluetooth chip. These devices provide a good solution for gateway.

Pushpin<sup>[13]</sup> is a sensor node that is part of a MIT project. Although main objective is for a portable computer, Pushpin's requirements also meet the wireless sensor network needs. It used a different approach for communication, using infrared. Its operational system Bertha is interesting since it tits in 8051 and its purpose is for distributed system.

In this paper we proposed a scalable and efficient WSN node design oriented acoustic positioning applications, adopted the combination of DSP and FPGA as the processor of the sensor node, used the 9XTEND to transfer demanded energy status. The most significant two innovations of the design are to realize the power control separately with other models and transfer the sleep/wake models on-demanded.

The existing mainly solution of the energy consumption for the WSN can divide by the different network layer as following.

Radio transmission optimization in the physical layer: In physical layer, how to reduce energy dissipation due to wireless communications and how to minimize the power consumption are more basically in the hardware basement. Researchers have tried to optimize radio parameters such as coding and modulation schemes<sup>[14]</sup>, power transmission and antenna direction<sup>[15]</sup> Transmission Power Control (TPC) has been investigated to enhance energy efficiency at the physical layer by adjusting the radio transmission power.<sup>[16,17]</sup>

Data reduction mechanism in the data-link layer: To reduce the amount of the data link to be transmitted to the sink is another way to gain saving. The data-link layer can limited the sensing tasks or the unneeded data in terms of energy. Data aggregation<sup>[18]</sup> and data compression<sup>[19]</sup> have discussed the energy saving affect from the data-link layer. Sleep/wake schemes also aim to adapt node activity to save energy by putting the ratio in sleep mode. There are different rules such as duty cycling schemes,<sup>[20]</sup> passive wake-up<sup>[21]</sup> or topology control<sup>[22]</sup>.

Energy efficiency routing in the Network layer: In the network layer, researchers control the energy by decline the routing burden in multi-hop schemes. There are so many traditional routing optimizing ways can put into WSN. Usually, routing metric <sup>[23]</sup> or cluster architecture <sup>[24]</sup> can gain more efficiency.

We analyze the network architecture of WSN and the energy saving scheme on it to chasing our own way to tackling the problem in object tracking. Then we proposed a sleep/wake schedule mechanism based on our node design. This paper is organized as follows. Section 2 introduced the design and implementation of the sensor nodes we proposed. Section 3 is focus on the power control and the status transfer on the node. Section 4 proposed the sleep schedule mechanism and analyzed it. Section 5 shows the experimental results and analysis. Finally, Section 6 concludes the paper.

## II. IMPLEMENTATION OF WSN ACOUSTIC LOCALIZATION NODE

### a. Design requirements of WSNs node

Wireless sensor node is the core of the sensor networks. The node communication distance and stored energy is limited due to the node volume, price, power supply and other factors. Although the structure of the sensor network nodes is different according to their various applications, the sensor network nodes generally have two components: the node hardware and embedded software. Node hardware mainly consists of the following four parts: data acquisition part ( sensor module ), data processing part ( processing module ), data transmission part ( wireless communication module ) and the power ( the energy supply module ) as shown in Figure 1 :

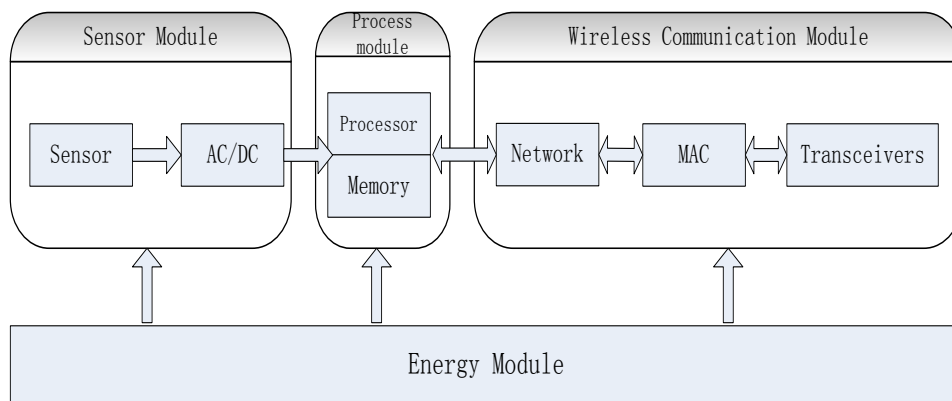

Figure.1 The architecture of wireless sensor node

### b. The architecture of the node

The development of a sensor network is strongly related to the intended application, and different applications have different performance requirements on the sensor network. We propose a new design of sensor network node for the acoustic localization which has the following modules: power module, data acquisition module, data processing module and wireless transceiver module. Power supply module is responsible for the supplying voltage of the rest major components. Because of the variety of different components, the voltage conversion module is mainly used to voltage converting and stability security of supply voltage. While there must have a function circuit providing a constant current source for the acoustic sensors power, its function is convert the constant voltage source into the constant current source. Microcontroller module is a key component of the sensor node. It is responsible for managing and scheduling other modules and tasks. Wireless communication module encodes/decodes commands and data, and facilitates wireless delivery with antennas. Sensor module collects information from surroundings and feeds them to the microcontroller for processing. The architecture of a sensor node is shown in Figure 2:

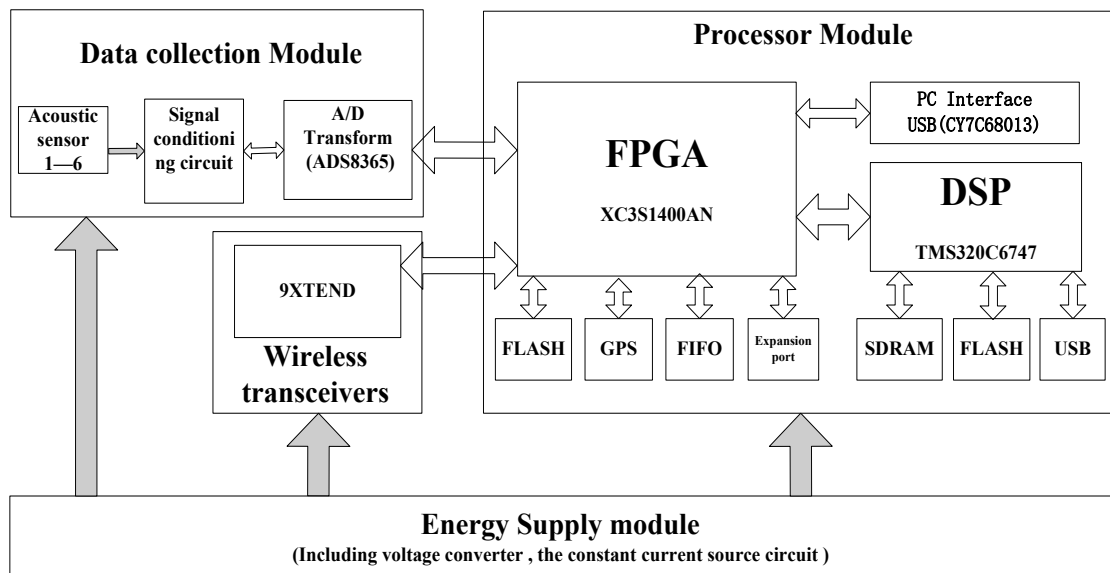

Figure.2 The architecture of the wireless sensor node

The node is designed as passive node which never sends the initiative probe signal. The acoustic sensor nodes awake from sleeping state and begin to synchronization with others only if there is acoustic object occurred in the monitoring area and the sound signal satisfies the acoustic sensor

acquisition range. The sleep/wake mechanism both can avoid enemy detection and location on itself, but also have on a significant effect on energy-saving. The details about the mechanism will be described in the next section, and we only focus on the hardware details in this section.

We use the combination of FPGA and DSP as the processor of the sensor node. The traditional sensor node adopt the single microprocessor (microcontroller, ARM, etc.) which brought enormous workload and serial data processing to the processor. We proposed the design of that the FPGA responsible for the synchronization, the DSP responsible for the data processing and the algorithms running. The data acquisition module transfers the object data to the processing module. The data first get the preliminary processing by the FPGA, and then sent to the DSP. DSP are not directly connected with the wireless transceiver modules, making the DSP work simplification. This design significantly reduces the workload of the DSP digital processing; improve the data processing efficiency and synchronization accuracy, especially increase the reliability of data processing. We will explain the implementation of the principle of each module as follow:

#### c. Data collection module

Sensor mainly percept and gather the information from external only as a part of collection module. In the acoustic localization WSNs, sensor mainly responsible for audio signal acquisition, sensor module usually consists of the sensor probe and transmission system two parts. The transmission system connected the sensor to the data processing module and the control module through sensor interfaces and takes the A/D conversion or filtering process to the received analog signal. It's crucial to select the appropriate sensor according to the actual requirements and load balancing.

We choose a high precision microphone concluding conditioning circuit produced by professional company as shown in Figure 3:



Figure.3 The picture of MPA416

The microphone has the following major features:

- 1) Small: MPA416 length 61mm, diameter of 1 / 4 ";
- 2) Free-field, wide frequency range, Frequency response range of 20Hz ~ 20KHz;
- 3) SMB Connection: allows MPA416 use only one SMB connection;
- 4) Simply application circuit: no any external components, reducing the node size, improving reliability, reducing energy consumption;
- 5) High sensitivity: The microphone sensitivity is  $\rho = 50\text{mV/Pa}$ .

The output voltage of the microphone signal can calculate by the following sound pressure level formula:

$$y(\text{dB}) = 20\lg\left(\frac{x(\text{Pa})}{2 \times 10^{-5}}\right) \quad (1)$$

Suppose the object signal is less than 127dB (The acoustic frequency human ear can hear), we can calculate the sound pressure maximum:

$$x = 2 \times 10^{\frac{y}{20}-5} = 2 \times 10^{1.35} \approx 44.77(\text{Pa}) \quad (2)$$

The microphone output peak voltage can be drawn according to the value of the sound pressure combined with the sensitivity of the microphone:

$$U = (\rho \times x) = (50 \times 44.77) \approx 2.24(\text{V}) \quad (3)$$

So the microphone output voltage range is:

$$-2.24\text{V} \leq U \leq +2.24\text{V} \quad (4)$$

Obviously, the energy consumption of the sensor can match the energy efficient requirements.

d. Data processing module

Most of the typical sensor data processing module using a single chip or ARM chip as a data processor such as AVR microcontrollers of the Atmel company , ultra-low power MSP430 series processors of TI and ARM processors.

Though these processors have excellent processing ability, they are not suitable the application characteristics of acoustic positioning and synchronization data processing needs, its digital processing speed can not transcend DSP. So we use DSP as data processing module microprocessors to process the position data and run synchronization algorithm. The FPGA is especially used to collecting the timestamp and send the clock data to DSP. The combination of these two processors made the sensor more efficient, there structure is shown in Figure 4:

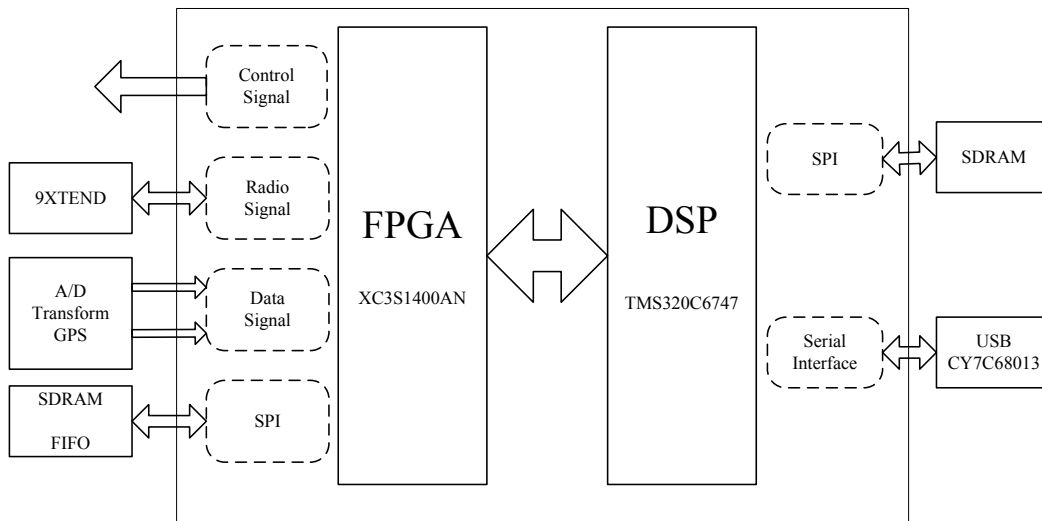

Figure.4 The structure of the data processing module

### III. THE POWER CONTROL AND ON-DEMAND SCHEDULE MECHANISM

Power supply module is the cornerstone of the entire node acquisition system, which provides power for all the running of nodes and fits the energy requirements. Since most of the nodes deployed in harsh environment, it cannot rely on conventional energy sources to provide industry electricity. The current development of typical nodes were powered via battery or solar energy and other natural supports, in this design, we take the mobile power supply module as the energy supply device.

We specifically designed voltage conversion circuit and the constant current source circuit to meet different reference voltage needs of the rest modules contains various types of chips to



ensure that each chip can work in the best conditions. In addition, the adoption of the plugged off power chip made each modules can control its power according the energy-saving requirements. The power requirements of the sensor node are various according the different chip as shown in Table 1:

Table 1: Voltage levels Type involved in System

Modules	Type of chip	Power requirements
Data collection module	Sensor MPA416	constant current source 、 2.5V reference
	ADS8365	Analog 5V、 Digital 3.3 V
Data processing module	DSP、 FPGA	Digital3.3 V、 1.2 V
	DSP_USB spared	Digital1.8 V
	SDRAM 、 FLASH 、 GPS 、 USB68013、	Digital3.3 V
	FIFO	Analog 5V
Wireless module	9XTEND	Analog 5V
others	LED	Analog 5V

We use 24V voltage source series of two 12V mobile power as the power supply device of the system. The LT1084 voltage converter switch 24V into 5V and then passed the voltage switcher to needed voltage level to supply the other circuits except the sensor which needed 24V constant voltage source directly supplying. Specific power supply module structure design schematics are shown in Figure 5.

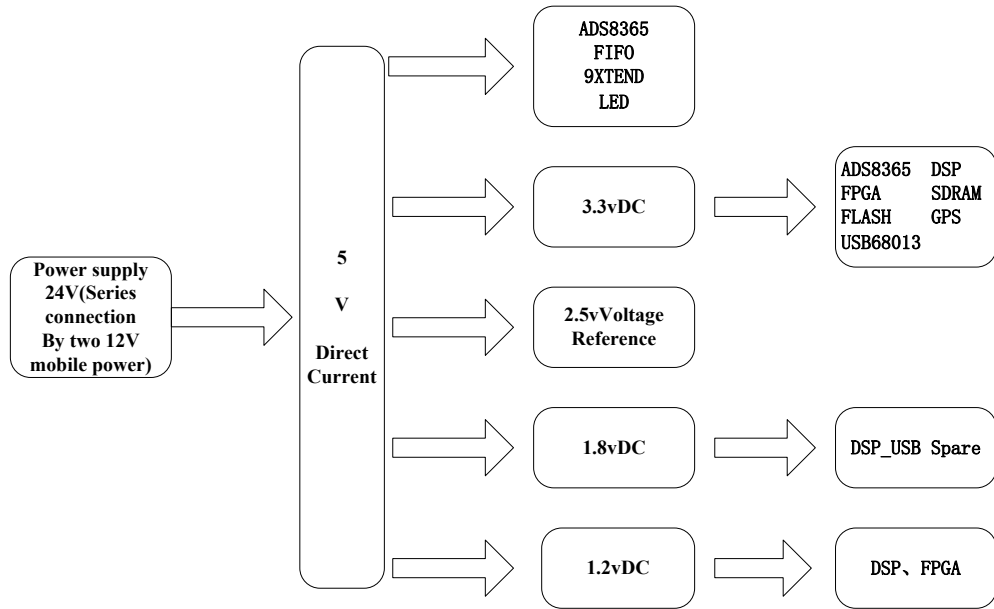

Figure.5 Power supplying Schematics figure

We ensure that each module can be individually controlled power switch in the circuit implementation processing easy to maximize energy savings. Specific design schematics shown in Figure 6:

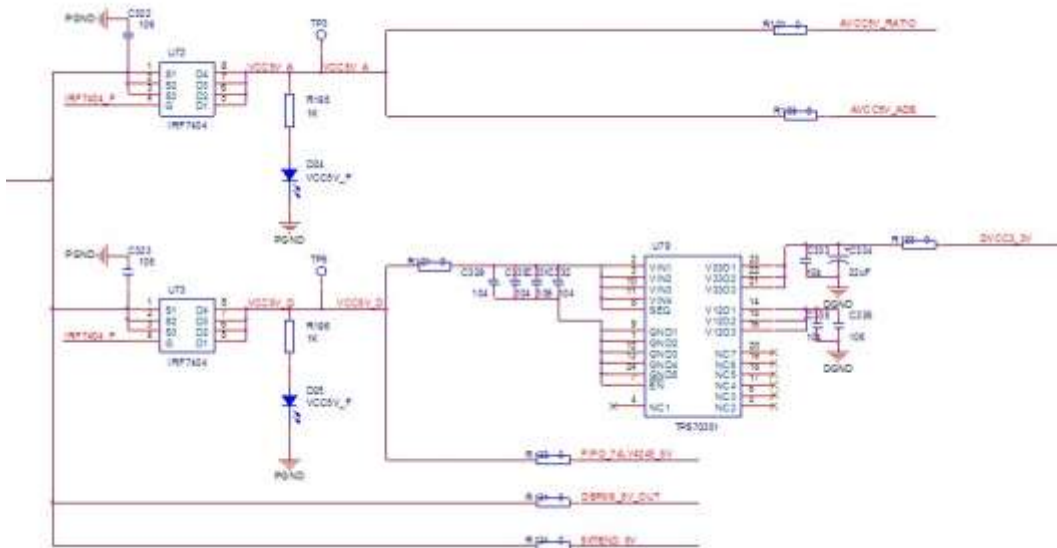

Figure.6 The circuit principle of Power control module

The power control is designed at the physical layer to reduce the burden of other layers. The individual control of each components supply the intelligence and extendibility for the node. We can control different interface on/off for different node. The node is shown in Figure 7.

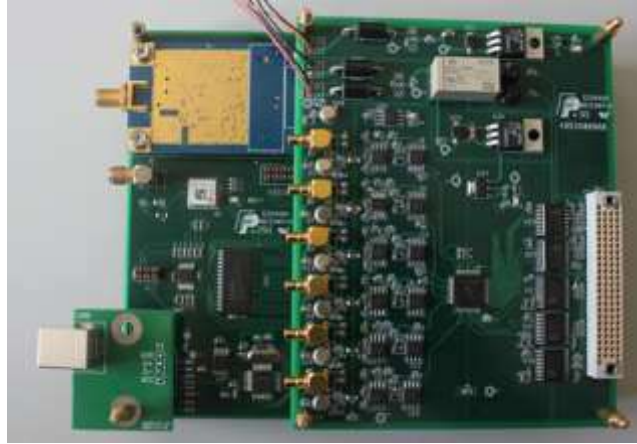

Figure.7 The Efficiency sensor node

#### IV. ON-DEMAND RATIO TRANSMISSION CONTROL AND THE SLEEP/WAKE SCHEDULING SCHEME

##### a. Ratio Transmission control on the Physical Layer

Wireless transceiver module is responsible for the data communications between the sensor nodes, nodes and base station. The carrier frequency selection, signal modulation, data rate, and coding method should be count in choosing a suitable wireless transceiver module. We adopt 9Xtend wireless chip from DIGI Company for its reliability, high data throughput and long distance ability as following:

- 1) 9Xtend works in ISM 900MHz band, uses frequency shift keying (FSK,) modulation, spread spectrum (FHSS, Frequency Hopping Spread Spectrum) communication.
- 2) Outdoor transmitting distance can reach 22km when equipped a bipolar antenna at 9600bps data rate,; 11km when equipped a bipolar antenna at 115200bps data rate 115200bps.
- 3) The receiver sensitivity can reach -110dBm at 9600 band,-100dBm at 15200 band.

4) 9XTend wireless communication module supports point- to-multipoint communication, resending answering, and 10 different bands.

5) The module uses 256-bit Advanced Encryption Standard (AES), provide high safety performance.

6) 9XTend wireless module supporting 2.8V-5.5V power supply, supporting software programming pin serial port and the cycle sleep mode, supporting hardware sleep mode that consumes only 5MA.

7) Full-duplex mode.

9XTend wireless module using asynchronous serial interface to communicate with the controller, and uses its own set of control protocols and functions of its main pin shown in Table 2.

Table 2: The main pin and functions of 9XTend

Pin number	Pin name	I/O	Function
1	GND	-	Ground power
2	VCC	I	Voltage: 2.8-5.5V
3	GPO2/RX LED	O	General Purpose Output 2; Wireless packet reception indication
4	TX_PWR	O	Wireless packet transmission instruction
5	DI	I	Asynchronous serial data input
6	DO	O	Asynchronous serial data output
7	SHDN	I	Hardware sleeping control, active when low
8	GPI2/SLEEP	I	General Purpose input 2; sleeping control
9	GPO1	O	General Purpose output 1
10	GPI1	I	General Purpose input 1
11	CONFIG/RSSI	I/O	Configuration Control; signal strength output
12-20	Reserved		

As shown in the table, THE TX\_PWR and RX LED can send and receive the wireless packets, we use these two pins to collecting the clock timestamp for the synchronization protocol, there timing diagram shown in Figure 8 and time parameters shown in Table 3:

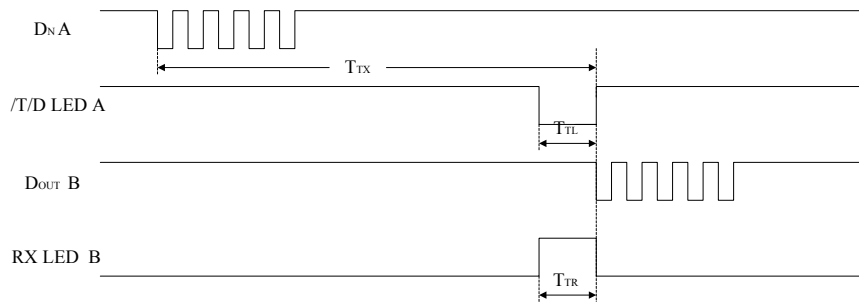

Figure.8 Timing diagram of the TX\_PWR and RX LED pin

Table.3 Time parameters of the TX\_PWR and RX LED pin

Symbol	Means	115200baud	9600baud
TTX	Sending delay	9.4ms	94ms
TTL	TX_PWR Time of low level	2.45ms	29.6ms
TRL	RX LED Time of high level	2.26ms	27.2ms

9XTend wireless module has six operating modes: Idle mode, transmitting mode, receiving mode, commanding mode, sleeping mode and off mode. The model state transition diagram shown in Figure.9:

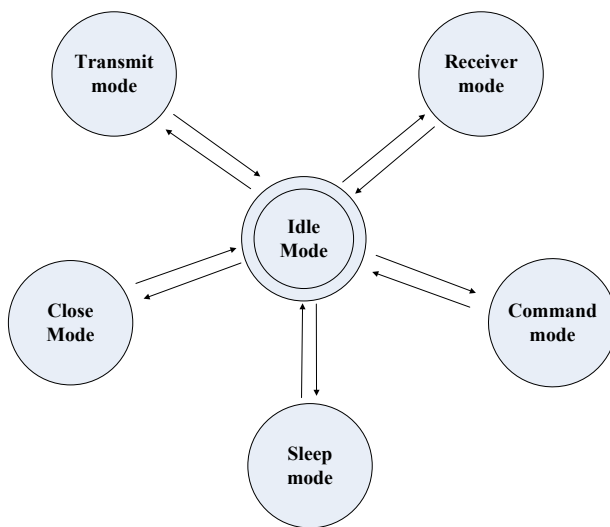

Figure.9 The model state transition diagram of 9XTend

Wireless module supports both hardware off and software off sleep mode, which can achieve low-power design. When the SHDN pin is set low, the wireless module turned into the hardware

shutdown mode which the VCC pin current is only  $5\mu A$  in this mode. The wireless module will be reset when the SHDN pin is set high, and then after about 100ms enters idle mode state. .9XTend can freely set to sleep mode, serial port sleep mode and cycling sleep mode by using the SM (Sleep Mode) command. The consumptions of these three modes are:  $147\mu A$ , 10mA, 1.6 mA .The consumption of the transmission and receiver mode are decided by the data scale and the network congestion state .Above status is shown in the Table 4:

Table.4 the consumption of Wireless Model in different modes

Type of mode	Power value
Off mode	$5\mu A$
Idle mode	$147\mu A$
Serial port sleep mode	10mA
Cycling sleep mode	1.6mA
Transmission mode	Decided by data scale
Receiver mode	Decided by data scale

#### b. Sleep/wake scheduling scheme

In the acoustic object tracking applications, the motivation of the system is to detect sense, collect and calculate the information of the interest object. All of the energy should be use efficiently to the object oriented. What we should do is to minimize the useless consumption of the other information or when the object is not moving. This is the basic idea of our mechanism. The object will irritated all of the sensors and the system until it is out of the work area. The node lifetime is all using to the object-oriented information.

We divided sensors into Listening node (LN) and Forwarding node (FN) according to individual responsibility. LN used to collecting data from the object and transmit them to the FN. FN used to forwarding data between LN and sink. They can set with the power control mechanism we have discussed in Section 3 to meet different functions. Before the object occurs at any of the node area, all of the network would set into the sleep mode without synchronization and other running activity except the LN. The sink will choose the FN and the remained node

will be the LN. When the LN find any new object it should send a wake beacon to the sink. Sink wake all of other nodes and synchronize the cluster. All of the nodes in sleep will wake and set the timer to sleep according to the beacon. We can see the processing in Figure 10. The total number of broadcast beacon frames is easy to account and be reduced compared with the traditional ways.

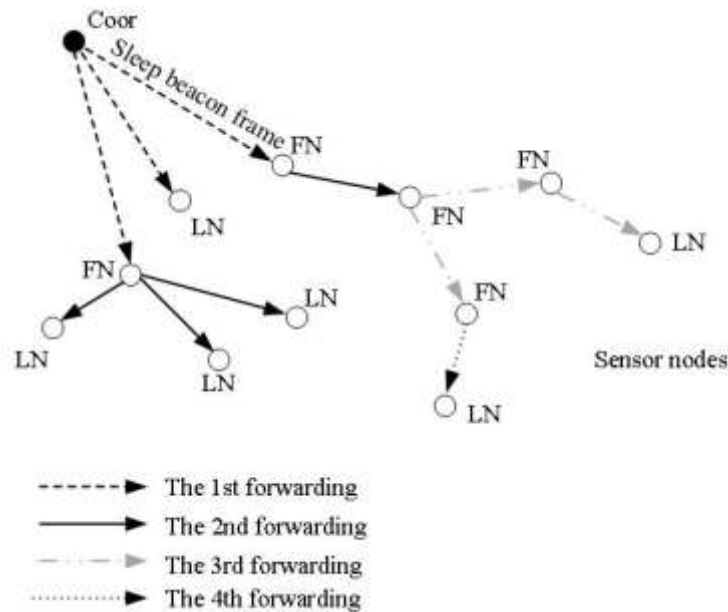

Figure.10 Enhanced synchronous sleep scheme

The algorithm is designed as following:

Algorithm: sleep/wakeup scheduling algorithm

**Input:**  $WI_{normal}$  the Wake Interval Normal

**Output:** sleep/wakeup schedule

**begin**

**check** region status by each node

**if** region status is region 1 **then**

set wake interval to  $3 \times WI_{normal}$

**else**

**if** region is region 2 **then**

set wake interval to  $2 \times WI_{normal}$

**else**

set wake interval to  $WI_{normal}$

**endif**

**endif**

**check** topology status by each node

**if** topology status is critical **then**

set wake interval to  $2 \times WI_{normal}$

**else**

set wake interval to  $WI_{normal}$

**endif**

```

follow up, by each sensor node, the determined sleep/
wake schedule and sense the environment for the occurrence
of the event for the specified interval defend by
sleep/wake schedule.
if event occurs then
set wake interval of event occurrence node to  $3 \times$ 
 $WI_{normal}$  set wake interval first hop neighbors of event occurrence
node to
 $2 \times WI_{normal}$  and send the message about the changed
wake interval to the first hop neighbors
change of sleep/wake interval by the first hop neighbor
upon receipt of the updated sleep/wake schedule
wait of the event occurrence node for the arrival of
next scheduled slot determined by self-timer before
sending the sensed event data
send the data to the next hop neighbor using three
way communication RTS, CTS and DATA.
endif
end
    
```

It is clearly to make the wake interval adaptive to the traffic load of the sensors. LN have greater traffic load as compared with the FN and are assigned longer wake intervals as shown in Figure 11.

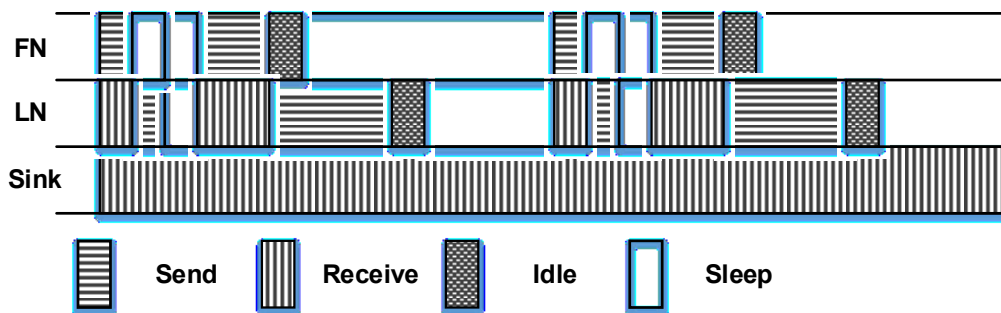

Figure.11 The sleep/wake pattern of nodes in the tracking system

Different nodes have on-demanded traffic load according to its individual functions. The result can be successfully minimized in both end-to-end delay and throughout of the whole cluster. It is obviously that the node design has improved the energy consumption and the network lifetime as well.

## V. EXPERIMENTS RESULTS ANALYSIS OF THE LOCATION NODE SYSTEM

In this paper, we propose an effective and feasible implementation scheme for WSN in object tracking. Our primary purpose is to maximize residual energy and application relevance of transferred status to extend the network lifetime. The energy efficiency in our node is tested at



the National Key Laboratory for Electronic Measurement Technology. We have set up a test-bed and conducted experiments with sensor nodes developed by our team. In the experiments, two batteries are used in series to provide energy for each sensor node. If the voltage falls below 2.5 V, the sensor node will not work correctly. Thus, we compare the voltage variation in the experiments so that we can know the power output and analyze the energy consumption. Figure 11 and Figure 12 show the variation of average voltage in the sensor nodes before and after the synchronous sleep scheme is used, respectively. Without the scheme, the sensor nodes continuously sense and send information about the surroundings such as temperature to the server. With the scheme, the sleep time is set to 15 min.

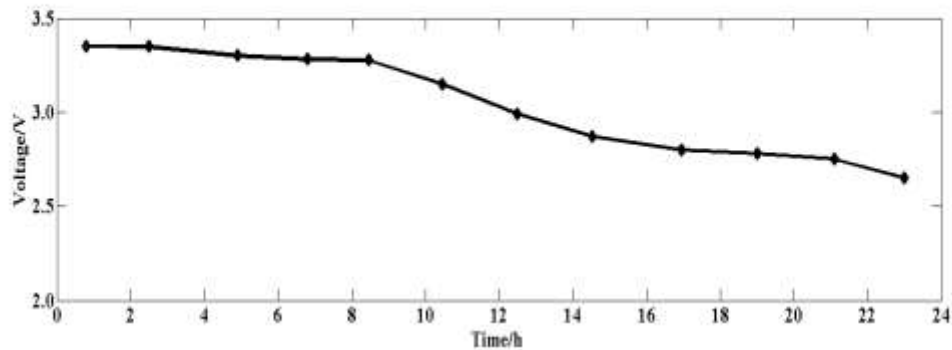

Figure.12 Voltage variation without sleep mechanism

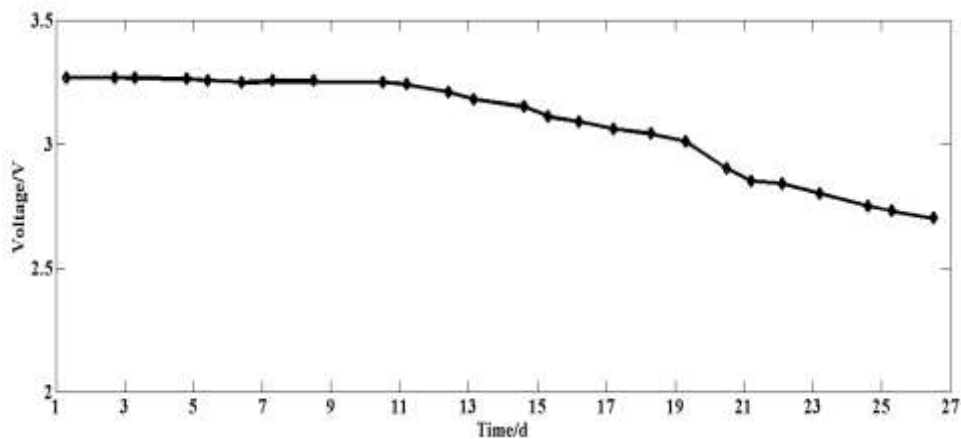

Figure.13 Voltage variations with sleep mechanism

In these figures, the vertical axis represents the remaining voltage measured in the sensor node. While the horizontal axis in the two drawings uses different time units to highlight their

differences. Please note that the remaining voltage is measured after the battery voltage has been adjusted with condition circuits.

In Figure 12, the unit is ‘hours’ and we can see that after about 22 hours, the remaining voltage has approached to 2.5 V. On the other hand, in Figure 13, the unit is ‘days’ and the remaining voltage stays above 2.5 V even after 25 days. Thus, the experimental results show that the sensor network will survive for one day or 25 days, depending on whether the sleep mechanism is implemented or not. It demonstrates that the proposed sleep and wake scheme is very effective in saving energy and can significantly extend the life time of the network.

The power control affect has been test and the result is shown in Figure 14. It shows the variation of average voltage in the sensor nodes before and after the power control mechanism is used, respectively.

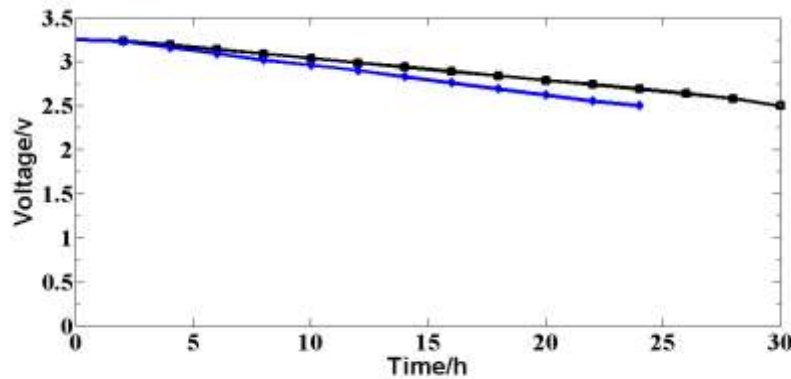

Figure.14 Voltage variation with or without power control

The result of experiments showed us that with the proposed power control scheme, the life time of sensor nodes is about 30 hours compared to 24 hours without power control scheme. The life time is improved about 25%, which illustrates the efficiency of the implemented power control scheme.

## VI. CONCLUSIONS

The tradeoff between energy consumption, node design and the transmission delay is taken into account in our paper. We designed an intelligent sensor node used to tracking the acoustic object in the Wireless Sensor Network. The node is chartered by individual power control and on-

demand pattern transferring. The function of the node including sensing, processing the data and realizing the power control according to the different uses. Then we proposed a sleep/wake schedule mechanism based on it try to reduce the traffic load to enlarge the lifetime of the network. Experiments are carried out to evaluate the performance of the proposed algorithm, by comparing its performance in the MAC layer. The results showed us the node design is feasible and efficiency and the proposed algorithm of sleep/wake schedule have significantly enlarged the node lifetime. In the future, the end-to end-delay and the accuracy of the tracking will be considered.

## REFERENCES

- [1] Gyula, Marklos, Maroti, Sensor network-based counter sniper system, Proceedings of the 2nd International Conference on Embedded Networked Sensor Systems, ACM, NY, USA (2004 ) 1-12;
- [2] Junfeng Qiao, Sanyang Liu , and Xiaogang Qi, Transmission Power Control in Wireless Sensor Networks under the Minimum Connected Average Node Degree Constraint, International Journal on Smart and Intelligent Systems, 2015,8(1),801-821.
- [3]HUANG Zhiwei, ZHENG Zimu, LI Zhicheng and PENG Xinyi, Connectivity-aware Topology Control with Cyclic-like Structures in Wireless Sensor Networks, International Journal on Smart and Intelligent Systems, 2014,7(4), 1663-1682.
- [4] Miguel S. Familiar, José F. Martínez, Pervasive Smart Spaces and Environments: A Service-Oriented Middleware Architecture for Wireless Ad Hoc and Sensor Networks, International Journal of Distributed Sensor Networks Volume 2012
- [5] A. Aroraa, P. Duttaa, A line in the sand: a wireless sensor network for target detection, classification, and tracking ,Computer Networks, Volume 46, Issue 5, 5 December (2004)605–634
- [6] IF Akyildiz, W Su, Y Sankarasubramaniam, E. Cayirci, Wireless sensor networks: a survey, Computer Networks 39 (2002) 393–422.
- [7] Alessandra Flamminia, Paolo Ferrari, Wired and wireless sensor networks for industrial applications, Microelectronics Journal, Volume 40, Issue 9, September 2009, Pages 1322–1336

- [8] Zoran M, Saric • Dragan D, Kukolj, Acoustic Source Localization in Wireless Sensor Network, *Circuits System Signal Process* (2010) 29: 837–856
- [9] Frost G P. Sizing up smart dust. *Computing in Science & Engineering*, (2003)5(6): 6–9.
- [10] J. Rabaey R. Broderson, Pico radio: Communication/Computation Pico nodes for Sensor Networks, *NTIS Technical Reports Newsletter*, Jan (2003)
- [11] <http://www.cens.ucla.edu/Project-Descriptions/Sensor/ZOPlatform/approach.htm>
- [12] Sung Park, Design of a Wearable Sensor Badge for Smart Kindergarten, *Proceedings of International Symposium on Wearable Computers*, October (2002), 231-238
- [13] Pushpin: <http://www.media.mit.edu/resenv/PushpiniWebSite>.
- [14] F.M. Costa, H. Ochiai, A comparison of modulations for energy optimization, in: *Wireless Sensor Network Links*, IEEE Global Telecommunications Conference, 2010, pp. 1–5.
- [15] S. Cui, A. Goldsmith, A. Bahai, Energy-constrained modulation optimization, *IEEE Trans. Wireless Commun.* 4 (5) (2005) 2349–2360.
- [16] S. Lin, J. Zhang, G. Zhou, L. Gu, J.A. Stankovic, T. He, ATPC: adaptive transmission power control for wireless sensor networks, in: *4th Int. Conf. on Embedded networked sensor systems*, 2006, pp. 223–236.
- [17] L.H. Correia, D.F. Macedo, A.L. dos Santos, A.A. Loureiro, J.M.S. Nogueira, Transmission power control techniques for wireless sensor networks, *Computer. Network.* 51 (17) (2007) 4765–4779.
- [18] E. Fasolo, M. Rossi, J. Widmer, M. Zorzi, In-network aggregation techniques for wireless sensor networks: a survey, *IEEE Wireless Commun.* 14 (2) (2007) 70–87.
- [19] N. Kimura, S. Latifi, A survey on data compression in wireless sensor networks, in: *Int. Conf. on Information Technology: Coding and Computing*, Las Vegas, NV, 2005, pp. 8–13.
- [20] R. Carrano, D. Passos, L. Magalhaes, C. Albuquerque, Survey and taxonomy of duty cycling mechanisms in wireless sensor networks, *IEEE Commun. Surv. Tutorials* 16 (1) (2014) 181–194.
- [21] C. Ranhotigamage and S. C. Mukhopadhyay, “Field Trials and Performance Monitoring of Distributed Solar Panels Using a Low Cost Wireless Sensors Network for Domestic Applications”, *IEEE Sensors Journal*, Vol. 11, No. 10, October 2011, pp. 2583-2590.
- [22] H. Ba, I. Demirkol, W. Heinzelman, Passive wake-up radios: from devices to applications, *Ad Hoc Netw.* 11 (8) (2013) 2605–2621.

- [23] S. Misra, M.P. Kumar, M.S. Obaidat, Connectivity preserving localized coverage algorithm for area monitoring using wireless sensor networks, *Comput. Commun.* 34 (12) (2011) 1484–1496.
- [24] A. Liu, J. Ren, X. Li, Z. Chen, X.S. Shen, Design principles and improvement of cost function based energy aware routing algorithms for wireless sensor networks, *Comput. Netw.* 56 (7) (2012) 1951–1967.
- [25] Y.M. Lu, V.W.S. Wong, An energy-efficient multipath routing protocol for wireless sensor networks, *Int. J. Commun. Syst.* 20 (7) (2007) 747–766.