



## VISION-INTEGRATED PHYSIOTHERAPY SERVICE ROBOT USING COOPERATING TWO ARMS

Huanbing Gao<sup>1,2</sup>, Shouyin Lu<sup>2</sup>, Guohui Tian<sup>2</sup>, Jindong Tan<sup>2</sup>

1, School of Control Science and Engineering

Shandong University

Jinan, China

Emails:gaohuanbing@163.com

2, School of Information and Electrical Engineering

Shandong Jianzhu University

Jinan, China

Emails:sdzjnqr@163.com

---

*Submitted: Feb. 20, 2014*

*Accepted: June 25, 2014*

*Published: Sep. 1, 2014*

---

*Abstract- This paper presents the mechanical architecture, control system, and other modules of a physiotherapy service robot which can treat degenerative disease and chronic disease of middle-aged and aged people by Chinese massage skill. The main body of the robot includes a massage adjustable bed, two 4-DOF(Degree of Freedom) robot arms and two massage hands that can accomplish various massage manipulations. Physiological signal and massage pressure are detecting in real time in massage process to ensure a scientific and safe therapy. Vision system sends the recognized acupoint position to the master system to track the patient's body, and the acupoint being massaged is displayed in real time by the 3D virtual model. The robot can execute ten massage manipulations, so that the traditional Chinese massage can have a robot instead. The effectiveness for degenerative lumbago in middle-aged and aged is demonstrated by laboratory examination and clinical trial..*

**Index terms:** physiotherapy robot, acupoint recognition, motion control.

## I. INTRODUCTION

Physiotherapy service robot is one of the service robots, which is developed for the clinical requirement of physical therapy and health care of degenerative disease and chronic disease of middle-aged and aged people. Physical therapy, e.g. massage, has a long history in China, but massage clinical treatment, a physical labor with strong intensity, is still made by experienced masseuse in hospital nowadays. There are some instruments simulating massage manipulations in the market right now, such as massager and massage chair, which can make a role of relaxing, care and eliminating fatigue, rather than treating diseases.

Sanyo Electric Co. realized the massage manipulations of pinching first in 1996 [1], and P. Minyong (Toyohashi University of Technology) et al., presented a four-fingers massage hand with pressure sensors in 2006 [2-5], which was able to create the movement and force of robot to behave as similar as the human's massage.

Tatsuya Teramae (Tottori University) et al., proposed the control strategy of the similar professional masseur's process. The appropriately impressed force is decided depending on the estimated elasticity, and the decided impressed force is realized by the impedance control [6]. Waseda University, also in Japan, has succeeded in developing the Waseda-Asahi oral-rehabilitation robot in 2007, which is composed by two six-degrees of freedom arms with plungers attached at their end-effectors [7-9]. Konkuk University has developed a massage robot tapping human backs in 2007, which is composed of a chair, a 1-DOF (degree-of-freedom) torso, monitor face, and two 3-DOF arms and hands [10]. All of above researches have realized some massage action, but making treatment plan according to acupoint is not mentioned.

R. C. Luo, C. C. Chang et al., in Taiwan, developed a relative new and feasible application of multi-fingered robot hands except for the use as prosthesis and grasping applications. And the Surface electromyographic signals (EMS) measured from the trapezius muscles before and after the massage therapy are analyzed [11-13]. But, they only used EMS rather than more representative electrocardiograph (ECG) etc. In China, Lei Hu, et al. (Beihang University), presented a finger-kneading manipulation model based on pain threshold and a hybrid force position control strategy, and they used visual servo to track massage position [14-15]. Xiaoqin Yin and Yonggen Xu of Jiangsu University put forward one parallel mechanism of 2-DOF

realizing 1 translation-1 rotation with single-opened-chain as a unit [16]. Jingguo Wang and Yangmin Li proposed a new application of 7-DOF redundant manipulator to do the massaging work for human feet with the tactile sensor equipped to the end-effector [17]. Above results are all theory research or laboratory products, and therapeutic effects have not verified through clinical test.

In this paper, we propose a physiotherapy service robot system, developed by the technology of Chinese massage, modern machinery, computer, control and mechanical-electrical integration, which can execute ten massage manipulations of finger-/palm-kneading, finger-/palm-rolling, pressing, pushing, tapping on lumbar and pinching, vibrating, patting on lower limb. It can calculate the coordinates of the acupoints and make treatment plan based on an expert system. It allows robot to replace human to do Chinese massage health care treatment, an ancient and meaningful work, so that the situation that health care resources are limited and an aging population structure society becomes more and more serious is effectively improved.

## II. MECHANICAL ARCHITECTURE

### III.

#### a. Main body

We have developed two models of physiotherapy service robot, whose names are JZMR-I and JZMR-II. The photos of them are shown in Figure 1.



Figure 1. JZMR-I and JZMR-II Robots

JZMR-I and JZMR-II have the same logic structures. JZMR-II builds an optimization model to improve JZMR-I on size, mechanism, the number and DOF of robot arm, and the structure of massage hand. The physiotherapy service robot system is composed of hoistable platform for massage, massage mechanical hand, two arms, acupoint recognition and positioning model, physiological signal detection model, motion control model, and 3-D virtual-reality model. The

remaining parts of the paper will give out every part respectively. Figure 2 shows the logic diagram of physiotherapy service robot.

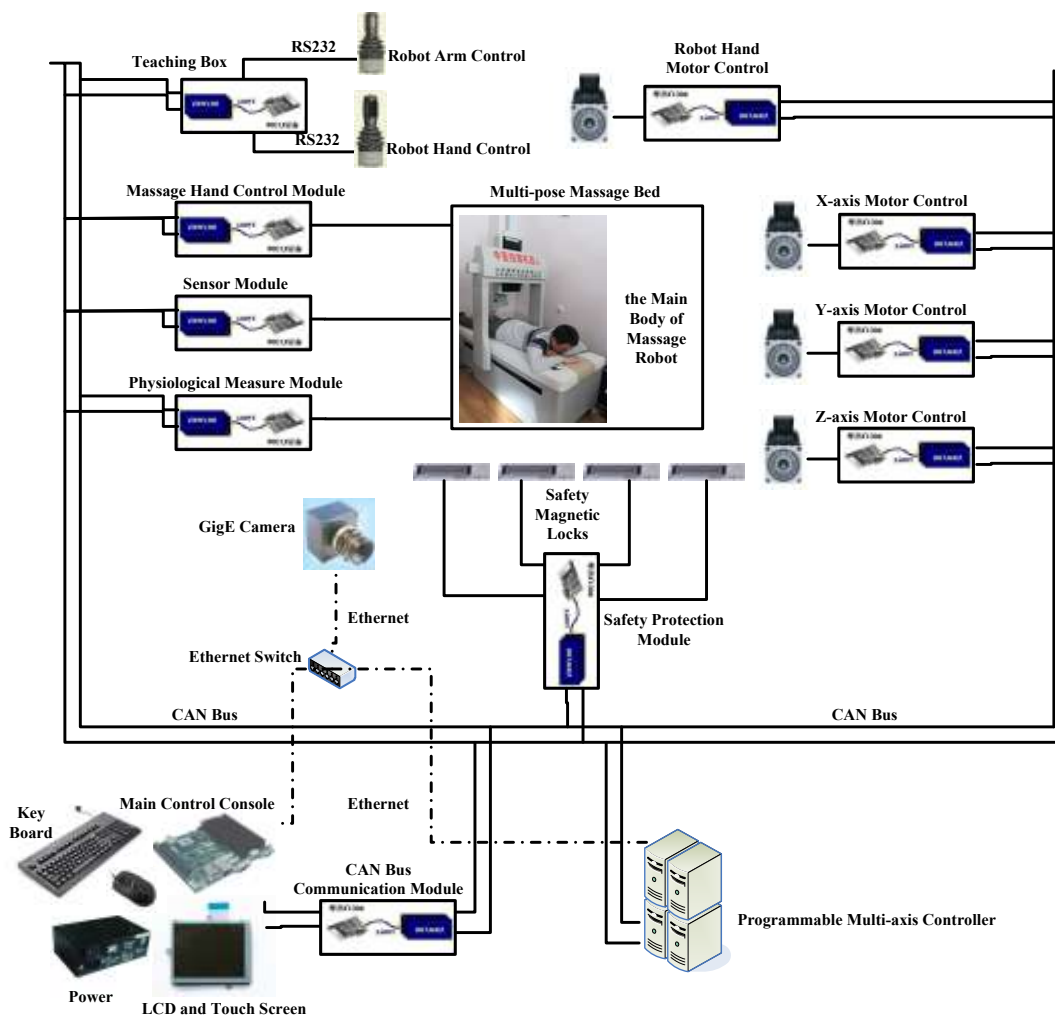

Figure 2. Logic diagram of physiotherapy service robot

The main body, also called massage platform, of JZMR-I robot is 2300mm long, 1000mm wide and the height of the massage bed can adjust in the range of 715-870mm. Both right and left robot arm can move respectively, on the Y axis direction of movement distance to reach 900 mm, Y axis direction to reach 1900 mm, and Z axis to reach 300 mm. Rotating arm can rotate around the Z axis with the rotation range  $\pm 60^\circ$ . The main body of JZMR-I robot is shown in Figure 3.

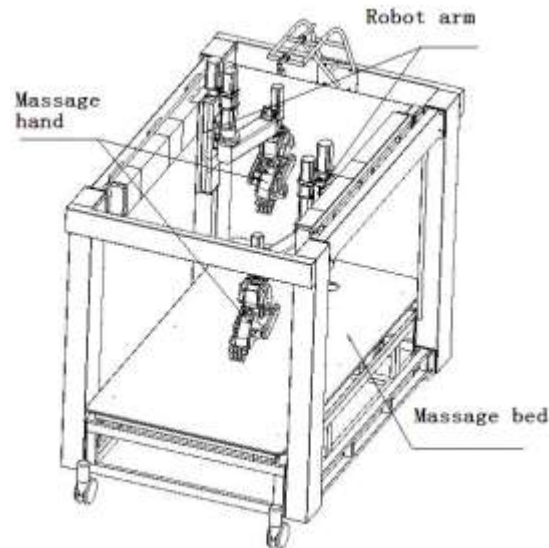

Figure 3. Main body of JZMR-I robot

In order to enhance the adaptability of space, JZMR-II robot reduced its size with 1900mm long, 550mm wide and the height of the massage bed is 500mm.

#### b. Robot arm

The robot arm architecture of JZMR-I robot combines rectangular type and joint type. Two arms working together are designed taking advantage of series structure and parallel structure because massage is a work that needs enough stiffness and accuracy. The robot arms mainly include three parts of horizontal movement mechanism, vertical movement mechanism and the deep movement mechanism, and the horizontal movement mechanism and vertical movement mechanism both are rectangular type. The greatest motion range of horizontal movement mechanism is 900mm and its highest speed can be up to 300mm/s. The greatest motion range of vertical movement mechanism is 300mm and its highest speed can be up to 80mm/s. While what the deep movement mechanism used is joint type mechanical structure with two axes named R1 and R2. The greatest motion angle of R1 is  $150^{\circ}$  and its highest speed can be up to  $50^{\circ}/s$ . The greatest motion angle of R2 is  $270^{\circ}$  and its highest speed can be up to  $50^{\circ}/s$ . The motion range of robot arm is shown in Figure 4.

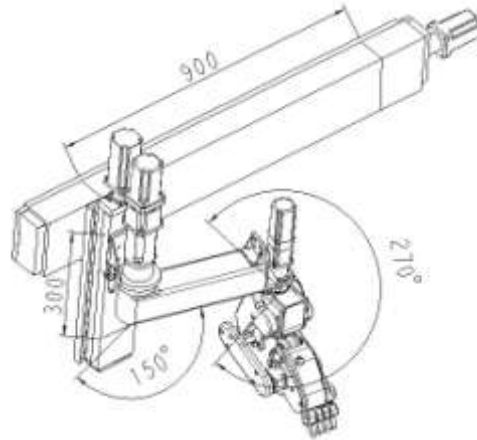

Figure 4. Motion range of robot arm

We create a three-dimensional Cartesian coordinate with the plane of massage platform as X-Y plane, from foot to head as the X axis direction. The motions in Y and Z axis are guided by linear bearings and linear shafts, and ball-screws are driven by servo motors to realize the movement of robot arm. Other motions of robot arm are all from joints rotation. The rotation arm can rotate in the range of  $\pm 60^\circ$ , and it can achieve the movement of massage hand on X-axis direction cooperating with the movement on Y-axis direction. Spinner Rack can rotate around the Z axis in  $270^\circ$  driven by plane rotation motor in order to realize the direction adjustment of massage hand.

The architecture of JZMR-II robot changed greatly. A gantry structure driven by X-axis robot arm is adopted. Another joint type robot arm that can rotate in a horizontal plane within the range of  $270^\circ$  is equipped on the gantry.

### c. Massage hand

A massage equipment that named massage hand by us is installed on the bottom of robot arm, which can execute Chinese massage imitating human. The massage hand can independently execute the massage manipulations of tapping, pinching, vibrating and patting. The maximum force of pinching motor is 70N, and the maximum force that palm and roller of massage hand can bear is 190N. The over-all structure of robot arm and hand are shown in Figure 3, and Figure 5 shows the structure of robot hand and the distribution of motors in it.

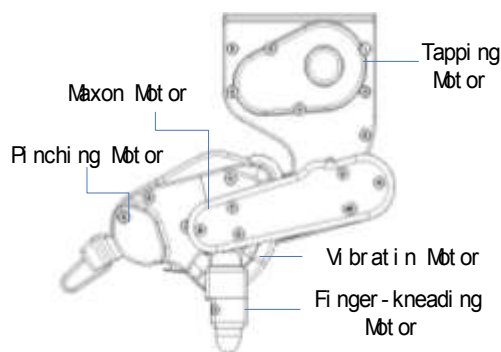

Figure 5. Structure of the massage hand

#### d. Security provided by mechanical structure

A function of fast falling is provided for adjustable massage bed to ensure the security. When a problem or exceptional situation occurs while a process runs, such as power outage, this function can probably be used. Under normal circumstances, a screw is locked at the opening of a sliding sleeve by a non-cylinder pin shaft inserted into the sliding sleeve and the screw. When the power cuts out, we can pull a bar to draw the non-cylinder pin shaft out, so the bed can fall fast by gravity through the sliding sleeve. When the power supply is back to normal, we can raise the bed by motors and the screw will be locked again by the non-cylinder pin shaft under force of a spring.

## IV. MOTION CONTROL SYSTEM

#### a. Functions of motion control system

The main function of motion control system is analyzing the command received from main control system by Ethernet, and controlling the movement of each axis on the robot arm. With the posture adjustment for massage hand, the movement of robot arm can locate the coordinated point and do different massage manipulation. On the other hand, some state parameters, including the values of each pressure sensor, the running statuses of robot arm and robot hand, and the trigger state of limit switches, etc, are sent to main control system by motion control system. The motion control system can continuously and smoothly move the robot hand to target point (any point in the massage space) of which coordinate is received from the main control system, and execute the massage manipulation.

b. Composition of motion control system

The core component of the motion control system is TRIO464 programmable multi-axis controller, and 13 axis driving interfaces, 32 digital I/O channels, and 10 analog signal input channels are provided with the cooperation of 4 extension modules of P874, P879, P325 and P316. All joints of the robot arm are driven by Panasonic servo motor that can provide accurate displacement and speed control, while the motors in robot hand are common DC motor except for the MAXON servo motor on the wrist. All of 8 servo motors are driven by PMAC and every servo motor has an encoder fed back to its driver, while all of 11 common DC motors are driven by PIC single chip processor.

Positive and negative limit switches are installed for all axes, and software limiting is provided to ensure the movement of the robot arm in a safe range.

At the same time, the motion control system can send real-time pressure data to main control system by the 10 sensors equipped on the thumb, palm, roller, finger array, and wrist of the robot hand, so the main control system can adjust the massage force less than anyone being massaged ought to endure , then the security is enhanced. The diagram of motion control system is shown in Figure 6.

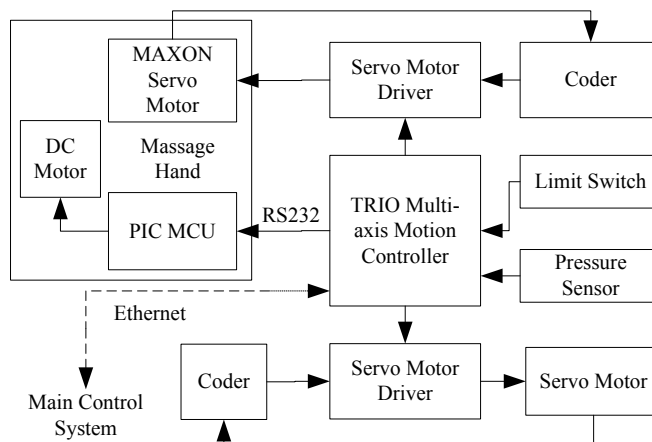

Figure 6. Diagram of motion control system

V. PHSIOLOGICAL SIGNAL DETECTIING SYSTEM

The physiotherapy service robot needs the real-time physiological signals of the massaged man, including blood pressure, sphygmus, ECG, etc. The physiological signals can help the robot to judge whether the massage force is suitable and whether the process is appropriate for going on.



As the massage in process, the physiological signals are also captured and displayed on the screen of the main control console as some curves, so the change rule can be shown conveniently. And the expert system will analyze these data to get the accurate characteristic, and guide the massage of the robot thereby.

Conceptual architecture of the module for ECG signal acquisition is shown in Figure 7: analog signal acquisition with electrodes, signal amplification, signal processing with a band-pass filter and analog to digital signal conversion. There are three types of electrodes, called wet, dry and insulated or capacitive electrodes, which are also used to capture other biosignals, such as EMG, EEG, etc. Wet disposable electrodes are nowadays prevailing in use. These are also used in our service robot.

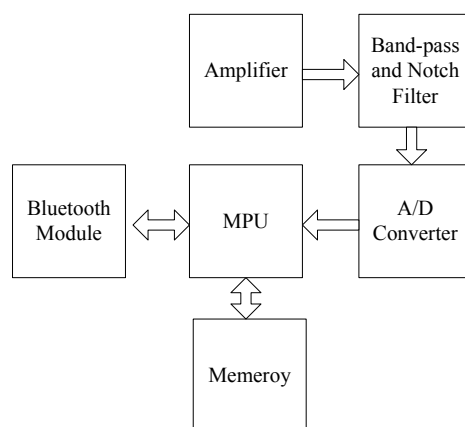

Figure 7. Conceptual architecture of ECG module

The signal from electrodes enters the amplifier system. The main issue with the ECG signal which reaches the amplifier is noise, which may have much greater amplitudes than the observed signal. Choosing the right amplifier largely depends on its noise characteristics. For example, common mode interference can be partially abolished by the instrumentation amplifier. To further eliminate interference, we use filters, which are set according to our understanding of the useful signal and interference. Since the frequency of most valid signal is between 0.05 Hz and 100 Hz, the cutoff frequencies of band-pass filter are set accordingly. Both, passive and active filters can be used in this case. Amplifying and filtering stage is followed by sampling and A/D conversion, to prepare the signal for digital processing. Theoretically the sampling frequency of 200 Hz is sufficient. However, in the event that we apply the analysis of ventricular late potentials and heart blocks, we must sample with a minimum of 1000 Hz, since the spectrum of

these disorders may extend all the way to 500 Hz. Sampling frequency is therefore chosen depending on the complexity of the ECG signal analysis.

For signal monitoring the module must be complemented with system memory, microcontroller and transceiver unit by using wireless communication of Bluetooth.

## VI. ACUPOINT RECOGNITION AND POSITION SYSTEM

### a. The form of acupoint recognition and position system

The robot has no good effect unless the point massaged is the accurate acupoint. The original coordinates of the acupoints are got by teaching as an expert physician moves the robot arm by a control stick. But the coordinates are not invariable because the patient would move his body inevitably when being massaged. The effect of massage will be decreased if the robot goes on massage according to original coordinates. So we designed a vision system to recognize and locate the acupoint. Some red marks are stuck on the acupoint of the patient, and a camera will capture the image and process it to get the positions of the marks. The system can judge whether the body is moved by comparing two adjacent images so the dynamic tracking for acupoint is realized[18][19].

The rectangular region that the robot hand can reach is 1900mm×900mm, while the actual massage region is less than 1500mm×500mm because the massaged positions are all on back, waist, and legs. We hope the tracking error is less than 2mm, but we must make the error less than 1mm in theory to allow for random errors caused by many interference factors. Comparing the massage region with the tracking accuracy, a conclusion can make that the corresponding actual object for one pixel of the image captured by the camera should be less than 1mm. After investigation, we select the uEye series industrial camera made by IDS Company in German, which is equipped with a very sophisticated high-speed CMOS sensor (resolution ratio of 1600×1200). The corresponding object for one pixel is 0.218mm by using the uEye camera with a 5mm lens. The camera can continuously shoot at the speed of 18 frames per second, that is, each shooting interval time is about 55ms, which meets the project's requirements.

### b. Acupoint detection

In order to facilitate matching, we choose the circular mark. The color of marks can be any, then the first work after acupoint detection program starting is to get the RGB value of the marks. After the marks fixed on the body, take an image and find the marks, and right click on any position of the marks, then the coordinate and RGB value of the pixel are recorded. But if we take a number of pictures even for the same color, each of the RGB value will be slightly different, especially in the case of the light is not strong enough. So a certain threshold of the RGB value is set to increase the probability of captured the marks.

Some image preprocessing, such as filtering noise and image enhancement, must be make beforehand. The commonly spatial adaptive noise filter can reduce the noise effectively, but at the same time leads to the loss of a large number of image edge detail information. By synthesizing multi-scale structural element in sharp method of morphology, we can sharpen the detailed edges of image. Then, erode the prior edges with multiple morphological structuring elements to obtain only one response to a single edge, or at least a fixed small number of responses and remove noise.

### c. Coordinate transformation

The origin for image from camera is the upper-left corner, and the y-axis positive direction is from left to right, while the x-axis positive direction is from top to bottom. There are 2 ways to get the z coordinate value of acupoint. One of the ways is teaching the coordinate value, that is, keep the robot hand moving down to the patient's body until it has touched the acupoint, then record the x-y-z value. The other way is measuring the z value by a camera mounted on the side of the massage bed. But in practice, we can stick the marks on the back of the patient, and make them as far as possible in the same plane, so the z coordinate value can be ignored.

The values in the recognition coordinates should be transformed into the motion coordinates. The relation of the two coordinates is shown in Figure 8.

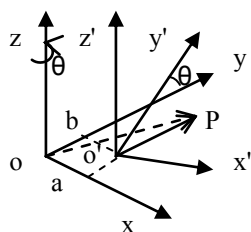

Figure 8. Coordinate transformation

The coordinate frame is robot motion coordinate frame, defined as A coordinate frame, while coordinate frame is image frame, defined as B coordinate frame. Because we ignore the change of z coordinates, B coordinate frame can be described as the result of a series of transformation from A: rotation  $\theta$  about z axis, then translation a units about x axis, and translation b units about y axis[20].

So we can get the homogeneous coordinate transformation matrix of coordinate frame A to coordinate frame B shown as Formula (1).

$${}^A_B\mathbf{T} = \begin{pmatrix} {}^A_B\mathbf{R} & {}^A\mathbf{P}_{BO} \\ \mathbf{0} & \mathbf{1} \end{pmatrix} = \begin{pmatrix} \mathbf{R}(z, \theta) & {}^A\mathbf{P}_{BO} \\ \mathbf{0} & \mathbf{1} \end{pmatrix} \quad (1)$$

In Formula (1),  ${}^A_B\mathbf{R}$  is the rotation transformation matrix, and  ${}^A\mathbf{P}_{BO}$  is the translation transformation matrix. So the homogeneous transformation matrix can be written as Formula (2).

$${}^A_B\mathbf{T} = \begin{pmatrix} {}^A_B\mathbf{R} & {}^A\mathbf{P}_{BO} \\ \mathbf{0} & \mathbf{1} \end{pmatrix} = \begin{pmatrix} \mathbf{R}(z, \theta) & {}^A\mathbf{P}_{BO} \\ \mathbf{0} & \mathbf{1} \end{pmatrix} = \begin{pmatrix} \cos\theta & -\sin\theta & 0 & a \\ \sin\theta & \cos\theta & 0 & b \\ 0 & 0 & 1 & 0 \\ 0 & 0 & 0 & 1 \end{pmatrix} \quad (2)$$

In Formula (2),  $\theta$ , b and a can be got by measure. So, there is a way to go from the image coordinates to the motion coordinates. If the coordinates of a mark in B is  ${}^B\mathbf{P}$ , the coordinates in A, written as  ${}^A\mathbf{P}$ , can be calculated out by Formula (2).

## VII. MAIN CONTROL SYSTEM

### a. The form of main control system

The main control system is the controlling and processing core of the whole robot system, and as the same time it is the direct access to learn the work state and work result of the robot. The following list contains functions of the main control system: scheduling the message tasks, planning the message actions, controlling the message motion, exception handling and man-machine interaction. The main screen of the main control system also displays the physiological signals of the massaged man, and the state of the massage platform and other parts of the robot. The main control system sends commands received from operation staff to the motion control

module and others. The main control system can be partitioned to 8 parts of module of communicating with motion controller, module of teaching controlling, interface module of physiological signals, interface module of acupoint recognition and position, module of 3D virtual reality, interface module of robot state and alarm, message expert system, management information module of the patient.

The main control system works as a DCS, with higher extendibility and reliability, to make every module cooperating with each other used the network of CAN and Ethernet. It controls the movement trajectory of robot hand according to the command from the control stick of the teaching module so the robot can record the positions of the reference points. The positions recorded can be update in real time by the vision position system.

An embedded PC module with an ultra low power processor of Intel Pentium M, is adopted by the main control system. A Windows XP OS is installed and the support for PS/2, USB, RS-232 devices is provided. The software is developed by Visual Studio 2005 and SQL SERVER 2005 is running as the database management system. The main graphic user interfaces are shown in Figure 9.

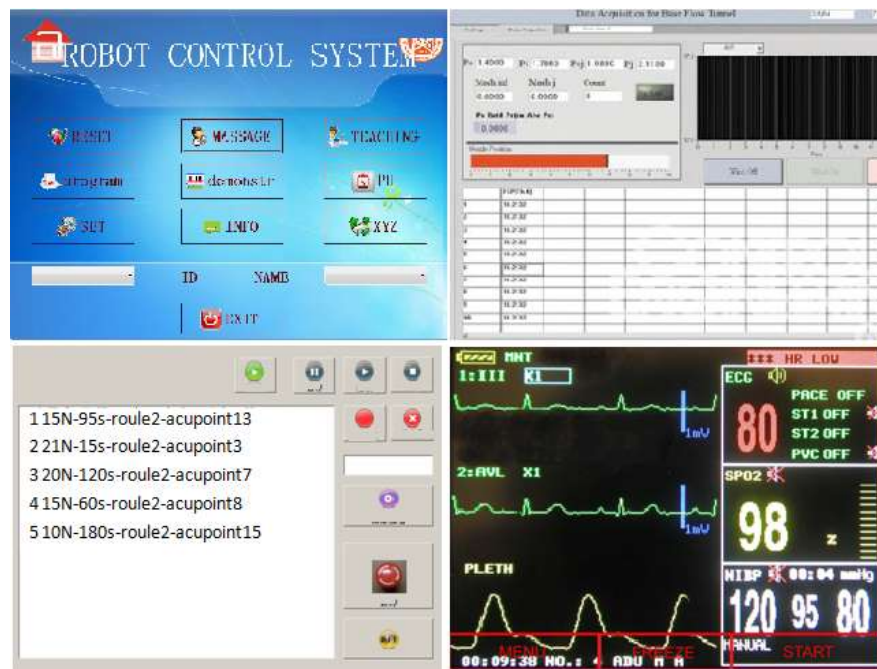

Figure 9. Main user interfaces

#### b. Communication interface for motion controller

The main control system sends command of message operation with TCP/IP-based communication to multi-axis controller to control the corresponding motors. The communication

must be reliable, because that, in any case, the communication can not be interrupted, otherwise, it will cause the fatal accident. Connection-oriented socket is adopted to ensure the reliability. The multi-axis controller made by TRIO is equipped with a TCP Server allowing multi-threading. When powered on, the TCP Server will start listening “502” port to wait for connection requests from client application. The main control system will create a TCP Client trying to connect to the TCP Server during startup. A socket communication stream is built as the TCP Server accepted the connection request.

The internal storage space of TRIO controller is divided into two kinds named Table and Var. If you want to send command to the TRIO controller, you can write to the corresponding Table. Likewise, if you want to know the state parameter of the TRIO controller, just read the corresponding Table. The instruction for reading and writing to Table can be found in the user guide provide by TRIO, and what we need to do is making these instructions into TCP data packet.

#### c. Visual positioning module interface

Visual positioning subsystem is the basic part of physiotherapy service robot and the precondition for guaranteeing normal massage performance. The position of human body is analyzed by the visual system through the collected image, the figure and the position of some key parts are determined according to the outline, and then the acupoints on body are located for massage according to TCM acupoint identification method.

Visual positioning subsystem runs as a separate process, thus communication problems with the main control system are involved. There are many communication modes among the inter-processes, commonly as shared memory, named pipe, anonymous pipe, messaging and other methods which can be used to complete the task directly. In addition, inter-process data communication task can be achieved indirectly through socket port, configuration file, registry and etc. The above methods have their own advantages and disadvantages, the method of excluding configuration file and registry can be used to solve fast switching problem of big data volume in process This system applies Windows WM\_COPYDATA message to realize the communication.

The declaration of the structure of WM\_COPYDATA in Windows API is as follows:

```
typedef struct tagCOPYDATASTRUCT {
```

```

DWORD dwData;
DWORD cbData;
PVOID lpData;
} COPYDATASTRUCT;

```

When apply WM\_COPYDATA message, window handle is specified and sent by the first message parameter, and the second message parameter is the indicator of data structure COPYDATASTRUCT which is related to same data. Among them, it only needs to give lpData to the first address of ready-to-send data, and data block length is designated by cbData. After message was sent, the receiver code in response function of WM\_COPYDATA message receives the data block through the second parameter which was transmitted with message.

Visual positioning subsystem can be started and stopped by main control system, “SendMessage” function is applied to send a WM\_COPYDATA message with startup parameter, identification point coordinate will be transmitted by visual positioning system at a fixed period, the transmission of coordinate also adopts WM\_COPYDATA message. After receiving the coordinate information, the two adjacent coordinate values will be compared by the main control system to calculate the offset, and then update relevant coordinate record. Sending a WM\_COPYDATA message with stop parameter can stop visual positioning system sending coordinate.

#### d. Teaching module

The teaching device of physiotherapy robot is main hand control system, which is mainly applied for teaching the acupoint position of human body. This device is made up of three parts of operating handle, data processing module and communication module. Operating handle adopts a triaxial Hall operating handle, the direction and angle of operating handle movement are converted to digital signal and encodes to output by data processing module, communication module is mainly used to achieve bus communication based on SJA1000 chip, which could connect teaching module into CAN bus network of robot system.

Click “Teaching” button to enter into teaching interface (shown in Figure 10). Teaching is a process of confirming the coordinate of massage acupoint. Remote control mechanical arm to reach massage acupoint and records the coordinate of this acupoint.



Figure 10. Picture of teaching interface

Click “Start Teaching” button, teaching mechanical arm moves to origin of coordinate waiting for command, after movement completed, mechanical arm movement is controlled by “+”, “-” control button on x, y, z axis, once mechanical arm reach acupoint position which needs to be calibrated, choose the name of acupoint in drop down box to record in the data base, and complete the teaching of this acupoint.

#### e. CAN interface

Robot system needs to be connected in a CAN bus network with teaching operating handle, blood pressure measurement module and pulse measurement module communication, since embedded PC of Intel Pentium M processor adopted by main control system does not have CAN communication interface, so we adopt the CAN to convert to RS-232, to use computer RS-232 bus to communicate with these equipments, it only needs to connect a CAN-RS232 mutual-conversion module to RS-232 interface of embedded PC[21-22].

NET Framework 2.0 class library includes important “SerialPort” class for controlling serial port, which conveniently achieves required various functions of serial communication. This class provides synchronization I/O and event-driven I/O, visit to base pin and interrupted state and visit to the property of serial driver.

## VIII. CLINICAL TRIAL

Clinical trial is performed to JZMR-I physiotherapy service robot at affiliated hospital of Shandong Traditional Chinese Medicine University. Clinical research is performed according to



Declaration of Helsinki and relevant clinical test research standards and regulations. Before the test research starts, test scheme is approved by research unit—ethics committee of affiliated hospital of Shandong Traditional Chinese Medicine University, the category of clinical trial is clinical verification, and verification range is lumbar intervertebral disc, it adopts research method that compares the effect before and after treatment, and put all subjects in group in chronological order to receive treatment and observation, 15 days is a course of treatment, and testers inspect subjects and therapeutic equipments and record the inspection result before test, during test and after test.

200 subjects are chosen in this trial, whose age are 45-65, and research objective, procedure, possible risk and their rights are fully introduced to them by research doctor, informed consent forms are signed and kept as appendix in research archives, subjects are treated according to predefined treatment course, and recovery rate, which could reflect clinical effect, can be calculated according to the grade before and after treatment. The test includes effectiveness observation item and safety observation item, and the result proves that the treatment effect of 200 cases is all effective. The photo taken during clinical trial is shown in Figure 11.



Figure 11. Clinical trial

## IX. CONCLUSIONS

The design process of physiotherapy service robot prototype is introduced in this paper. A massage hand which can integrate many massage skills is designed for this service robot and high safety new massage robot body mechanism is designed to achieve 10 typical TCM massage manipulations. Massage process can be adjusted according to real-time physiological signal and feedback from acupoint identification system, but the cost of this prototype is quite high, in order to promote the industrialization of massage robot, how to reduce cost of mechanical structure and

control system needs to be considered. In addition, freedom degree of mechanical arm could be increased to achieve massage manipulation flexibly. Clinical course also found that teaching process is very long, so it could be improved to visual system teaching method, which would greatly improve efficiency.

#### ACKNOWLEDGEMENT

This work was supported by National High-tech Research and Development Projects (863), under the Grants 2010AA040201 and 2012AA041506.

#### REFERENCES

- [1] M. Kume, Y. Morita, Y. Yamauchi, H. Aoki, M. Yamada, K. Tsukamoto, "Development of A Mechanotherapy Unit for Examining the Possibility of An Intelligent Massage Robot", *Intelligent Robots and Systems*, vol. 1, 1996, pp. 346-353.
- [2] K. Terashima, H. Kitagawa, T. Miyoshi, P. Minyong, T. Kondo, "Modeling and Massage Control of Human Skin Muscle by Using Multi-fingered Robot Hand", *Integrated Computer-aided Engineering*, vol. 13, no. 3, 2006, pp. 233-248.
- [3] P. Minyong, K. Mouri, H. Kitagawa, T. Miyoshi, K. Terashima, "Hybrid Impedance and Force Control for Massage System by Using Humanoid Mmulti-fingered Robot Hand", *Proceeding of the 17th World Congress*, pp. 15742-1549, 2008.
- [4] P. Minyong, T. Miyoshi, H. Kitagawa, K. Terashima, "Expert Massage Motion Control by Multi-fingered Robot Hand", *Proceeding of International Conference on Intelligent Robotics and Systems*, pp. 3035-3040, 2003.
- [5] Mouri Keisuke, Terashima Kazuhiko, Minyong Panya, et al., "Identification and Hybrid Impedance Control of Human Skin Muscle by Multi-fingered Robot Hand", *Proceeding of IEEE International Conference on Intelligent Robots and Systems*, pp. 2895-2900, 2007.
- [6] Tatsuya Teramae, Daisuke Kushida, Fumiaki Takemori, et al., "Control Strategy for the Massage Chair Based on Human Skin Elasticity", *Proceeding of SCIE Annual Conference*, pp. 631-636, 2007.

- [7] Koga Hiroki, Usuda Yuichi, Matsuno Masao, et al., "Development of Oral Rehabilitation Robot for Massage Therapy", Proceeding of the IEEE International Conference on Information Technology Applications in Biomedicine, pp. 111-114, 2007.
- [8] J. Solis, Y. Obokawa, H. Ishii, H. Koga, A. Takanishi, A. Katsumata, "Development of Oral Rehabilitation Robot WAO-1R Designed to Provide Various Massage Techniques", Proceeding of 2009 International Conference on Rehabilitation Robotics, pp. 457-462, 2009.
- [9] Y. Obokawa, J. Solis, H. Ishii, H. Koga, A. Takanishi, A. Katsumata, "Clinical Massage Therapy with the Oral-rehabilitation Robot in Patients with Temporomandibular joint disorders", Proceeding of 9th Information Technology and Applications in Biomedicine, pp. 1-4, 2009.
- [10] Chulgoo Kang, Bongju Lee, Ikxu Son, et al., "Design of A Percussive Massage Robot Tapping Human Backs", Proceeding of 16th IEEE International Conference on Robot and Human Interactive Communication, pp. 962-967, 2007.
- [11] R. C. Luo, C. C. Chang, Yiwen Perng, "Impedance Control on A Multi-fingered Robot Hand Based on Analyzed Electromyographic Information for Massage Applications", Proceeding of 2009 IEEE International Symposium on Industrial Electronics, pp. 1228-1233, 2009.
- [12] R. C. Luo, C. C. Chang, "Electromyographic Evaluation of Therapeutic Massage Effect Using Multi-finger Robot Hand", Proceeding of 2011 IEEE International Conference on Robotics and Automation, pp. 2431-2436, 2011.
- [13] R. C. Luo, C. C. Chang, "Electromyographic Signal Integrated Robot Hand Control for Massage Therapy Applications", Proceeding of Intelligent Robots and Systems (IROS) 2010, pp. 3881-3886, 2010.
- [14] Xu Ying, Yao Tengzhou, "Simulation and implement of traditional Chinese finger-kneading based on hybrid force position control", Proceedings of 2nd International Conference on Information Science and Engineering, pp.5384 -5387, 2010.
- [15] Hu Lei, Lv Zhentian, "Visual servo control in Massage robot", Proceedings of 2nd International Conference on Information Science and Engineering (ICISE), pp. 5528-5530, 2010.
- [16] Yin Xiaoqin, Xu Yonggen, "Design and simulation of Chinese massage robot based on parallel mechanism", Proceedings of 2010 International Conference on Mechanic Automation and Control Engineering (MACE), pp. 2512-2515, 2010.

- [17] Jingguo Wang, Yangmin Li, "Massaging human feet by a redundant manipulator equipped with a tactile sensor", Proceedings of 2010 IEEE/ASME International Conference on Advanced Intelligent Mechatronics (AIM), pp.7-12, 2010.
- [18] Maher Assaad, Israel Yohannes, Amine Bermak, Dominique Ginhac and Fabrice Meriaudeau. "DESIGN AND CHARACTERIZATION OF AUTOMATED COLOR SENSOR SYSTEM". International Journal on Smart Sensing and Intelligent Systems, VOL. 7, NO. 1, 2014, pp.1-12.
- [19] Xianxian Tian, Hong Bao, Cheng Xu and Bobo Wang. "PEDESTRIAN DETECTION ALGORITHM BASED ON LOCAL COLOR PARALLEL SIMILARITY FEATURES". International Journal on Smart Sensing and Intelligent Systems, VOL. 6, NO. 5, 2013, pp. 1869-1890.
- [20] G.Sengupta, T.A.Win, C.Messom, S.Demidenko and S.C.Mukhopadhyay, "Defect analysis of grit-blasted or spray printed surface using vision sensing technique", Proceedings of Image and Vision Computing NZ, Nov. 26-28, 2003, Palmerston North, pp. 18-23.
- [21] Cai Z X, "Fundamentals of robotics", Beijing: China Machine Press, 2010.
- [22] G. Sen Gupta, S.C. Mukhopadhyay, C. H. Messom and S. Demidenko, "Master-Slave Control of a Teleoperated Anthropomorphic Robotic Arm with Gripping Force Sensing", Proceedings of 2005 International Instrumentation and Measurement Technology Conference, May 17-19, 2005, Ottawa, Canada, IEEE Catalog Number 05CH37627C, ISBN 0-7803-8880-1, Page number-2203-2208.
- [23] Tao Wang, Zhaotong Liu and Yanping Li. "Research and Realization of the Chinese Massage Robot Based On Three-dimensional Model", Proceedings of 8th World Congress on Intelligent Control and Automation. Piscataway, pp. 6493-6497, 2010.
- [24] G. Sen Gupta, S.C.Mukhopadhyay, S. Demidenko and C.H.Messom, "Master-slave Control of a Teleoperated Anthropomorphic Robotic Arm with Gripping Force Sensing", IEEE Transactions on Instrumentation and Measurement, Vol. 55, No. 6, pp. 2136-2145, December 2006.
- [25] Tao Wang, Taixue Bei and Yanping Li, "Research and Realization of the Robot Massage Evaluation System Based On Fuzzy Set Theory", Proceedings of 8th World Congress on Intelligent Control and Automation. Piscataway, pp. 6498-6501.