



## REAL TIME STEAM TEMPERATURE REGULATION USING SELF-TUNING FUZZY PID CONTROLLER ON HYDRO- DIFFUSION ESSENTIAL OIL EXTRACTION SYSTEM

Zakiah Mohd Yusoff, Zuraida Muhammad, Mohd Hezri Fazalul Rahiman, Mohd Nasir Taib

Faculty of Electrical Engineering

UiTM Shah Alam,

Selangor, Malaysia

Emails: [zakiah\\_darwisy@yahoo.com](mailto:zakiah_darwisy@yahoo.com)

---

*Submitted: Aug. 11, 2013*

*Accepted: Nov. 16, 2013*

*Published: Dec. 16, 2013*

---

*Abstract- The essential oil is mostly depends on the temperature. The temperature will influence the final product of the extraction process. The existing steam distillation processes are giving less intention on this issue. This work implemented the robust self-tuning fuzzy PID (STFPID) controller to monitor the steam temperature in the hydro-diffusion essential oil extraction system. The hydro-diffusion system is built to overcome some weakness of existing systems. The effectiveness of the STFPID using 25 rules and PID controller is measured by using performance indices of settling time, rise time, percentage overshoot (%OS) and root mean square error. The step responses analysis and robustness test show that STFPID and PID controller are able to drive the steam temperature to the*

*desired set point However, the analysis shows that STFPIID produces better performances based on set point tracking and adoption of load disturbance.*

**Index terms:** distillation, essential oil, hydro-diffusion system, self-tuning fuzzy PID

## I. INTRODUCTION

Recently, essential oil gained a great popularity and promises various significant benefits to human and industry such as in aromatic and fragrances[1-3], medical activities[4, 5], as insect repellents and pesticides[6, 7], nutraceutical or cosmetics[1, 3, 8, 9], as a natural additive for food flavouring[4, 5, 10], anti-tumour activity[7], anti-bacteria[8, 11, 12], anti-cancer, anti-mutation[8], anti-fungal, antimicrobial activity[11, 12], , pharmaceutical industries[6, 9, 10] and soil enrichment[7] according to the composition of the oil.

Steam distillation is one of most preferable extraction methods to obtain essential oils. It is still reliable alongside with the modern technique to produce 93% of extracting oil while the remaining 7% is extracted by other techniques [13, 14]. The extraction process takes long duration at least 3 hours to complete the process and sometimes need longer than that to complete for a single process [15-17]. This circumstance may result in the loss of the volatile compound of extracting material, some water soluble constituents, excessive heat will cause the thermal degradation which significantly affects the aromatic profiles, colors of essential oil and giving undesirable off-flavor compound[4, 13, 18]. This study proposed that the steam temperature of extraction process should regulate to maintain the quality and yield of extracting oils as had been published in[14, 19, 20].

During the past several years, fuzzy logic controller (FLC) which is firstly applying by Mamdani in mid 70's has emerged as one of the most active and fruitful areas for research in the application of fuzzy set theory[21, 22]. A fuzzy control provides a formal methodology for representing, manipulating and implementing a human's heuristic knowledge about how to control a system[23]. Effective utilization of fuzzy control has been successfully applied in numerous applications such as water quality control, automatic train operation system, fuzzy logic controller hardware systems, elevator control, nuclear reactor control, and fuzzy computers[21]. The FLC is one of the well-succeeded technologies for development of sophisticated process control systems[24].

The self-tuning fuzzy PID controllers (STFPID) were designed with the intention to improve the PID controller performances[25]. The self-tuning fuzzy PID controller actually is the combination of PID controller and fuzzy controllers and act as an effective tool for many control systems [26]. There is a large volume of published studies describing the implementation of STFPID controllers such in steam temperature regulation [14, 27, 28], position control of shape memory alloy actuators [26], industrial hydraulic actuator[25, 29], gasoline refinery catalytic reformer[30], and plastic injection molding process[31]. The STFPID controllers are more attractive for industrial use since can overcome the limitation of PID controllers such as parameters change and disturbed by unknown facts [29, 32]. The STFPID controller has the advantageous over PID controller by significantly reduce rise time and percentage overshoot [14, 29].

## II. HYDRO-DIFFUSION ESSENTIAL OIL EXTRACTION SYSTEM

The photo of hydro-diffusion essential oil extraction system is shown in Figure 1 and installed at Distributed Control System Laboratory (DCS), Faculty of Electrical Engineering, University Technology Mara Shah Alam, Malaysia.



Figure 1. The hydro-diffusion essential oil extraction system

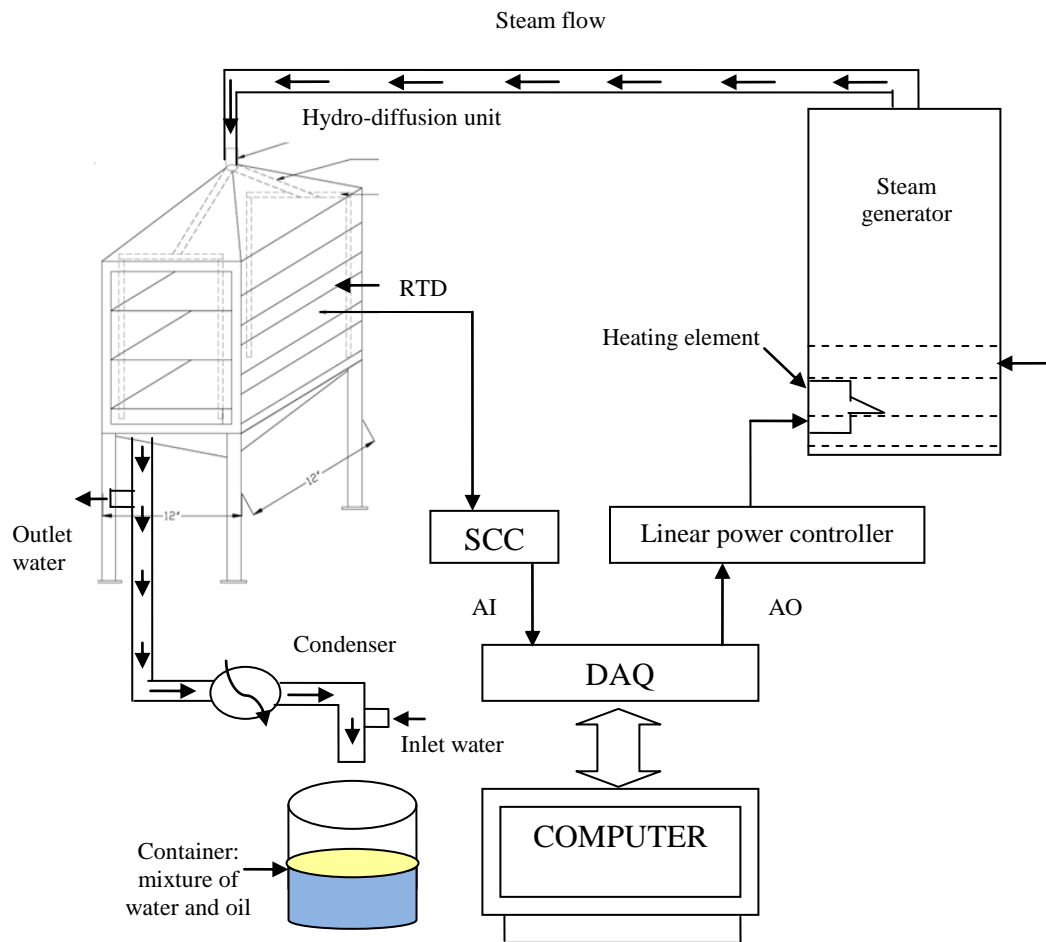

Figure 2. The schematic diagram for complete system set-up

The schematic diagram of hydro-diffusion system apparatus as illustrated in Figure 2 above. It is consisted of two main parts, which is the steam generator and hydro-diffusion unit. Two RTD PT-100 measures the steam temperature in the middle of the hydro-diffusion unit and water temperature in the steam generator were used

The steam distillation is a widespread method to isolate the essential oil from aromatic plants. Although conventional steam distillation system is characterized by a simple process, cleaner production and low operational costs but losses of some volatile compounds, solvent residue and volatile compounds were significantly diluted with water and will be forever lost is undeniable[15, 33]. The hydro-diffusion system was implemented as a viable alternative to overcome these faults. The hydro-diffusion is a small scale tray, simple, easily constructed apparatus was inspired by the existing steam distillation system but the construction is different.

Its applied a new technique in extracting the essential oils. The study applied a hydro diffusion concept where steam and extract (water and essential oil) move thus naturally downwards by gravity to a condenser[8]. It is opposite from the conventional steam extraction where steam which act as a transportation medium carry oil goes upward. By using conventional steam distillation, the steam is not fully used for extraction. As steam is passed through the material tray, it condenses in the first element before going to the next and so on, where it releases its enthalpy of vaporization. The steam that releases their enthalpy have the probability to go back to the distillation column. This can be proved by examining the water in the distillation column. Long extraction time the water become darker. The hydro-diffusion system enhances oil recovery by minimizing oil waste in boiling water. Numerous studies mentioned that by using a conventional steam distillation process, residual oil dissolved in the water will cause an odor nuisance and waste of the valuable product in the water stream[34].

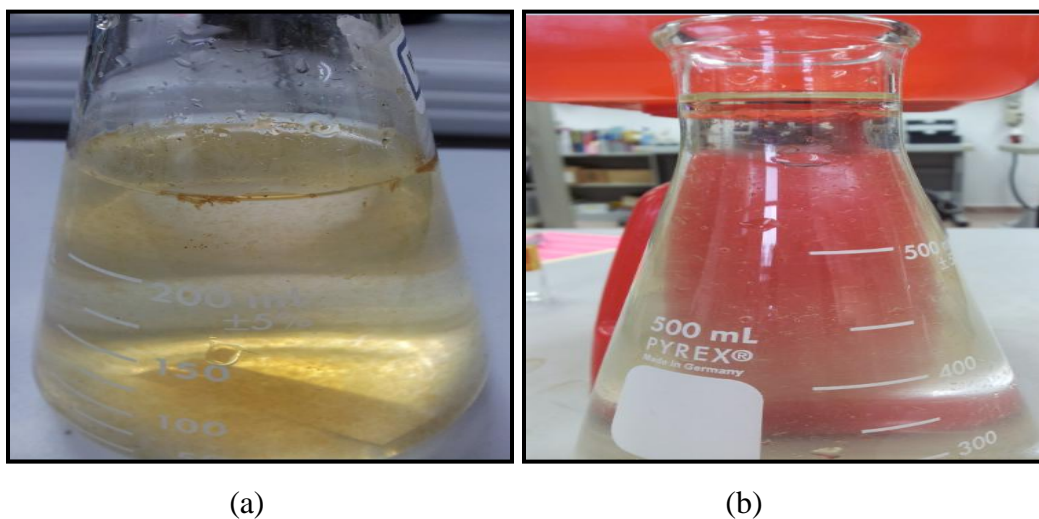

Figure 3(a). Water in distillation column using conventional steam distillation after extraction process and Figure 3(b). water in distillation column using hydro-diffusion extraction system

System configuration of the hydro-diffusion system consists of three main parts, which are system plant, data acquisition using PCI-1711 card and lastly control unit. The block diagram for system configuration is shown in Figure 4

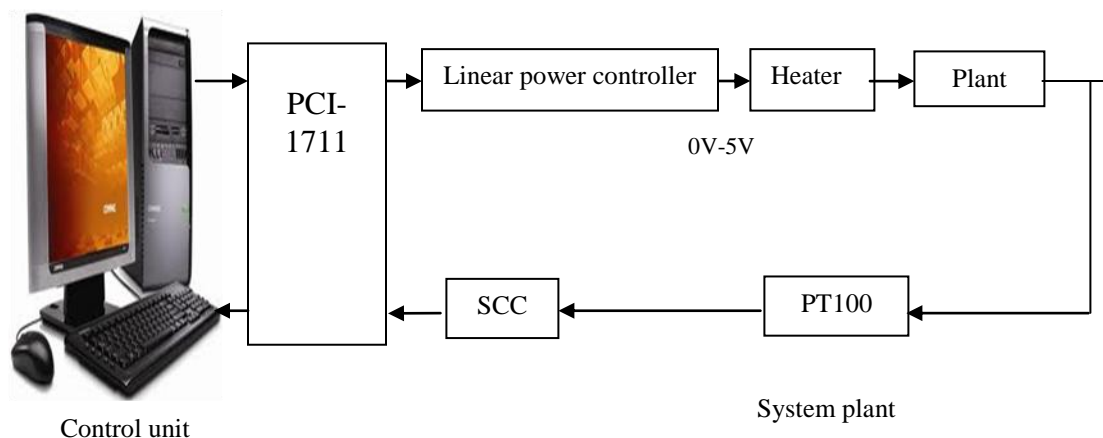

Figure 4. Block diagram of hydro-diffusion system

The computer was used as a control unit. DAQ PCI-1711 Advantech LabCard was used to interface between hardware and control unit through port A11. The system consists of three phase 240 Vac immersion type heater with a power rating of 1.5kW. The sensor is a platinum sensing element, RTD PT-100 3 wire type placed in the middle of the hydro-diffusion unit to measure the steam temperature. This sensor is selected because of it offer excellent accuracy, user friendly and wide range of applications. RTD PT-100 was connected with the signal conditioning circuit (SENECA K109PT) varies in terms of resistance value of  $100 \Omega$  at  $0^{\circ}C$ . The power controller was regulated by linear power controller (STOM 1) to produce the voltage range from 0V to 5V then send to the heater. Software for the system was developed using MATLAB version R2009a programming to monitor the signal response. The collected data at the workspace will be saved in .mat format. MATLAB Real-time Workshop (RTW) was employed for real-time implementation.

### III. CONTROLLER DESIGN

In this study, two types of controllers will be concentrated which are the conventional PID and STFPID controllers. The purposed of designing controller is to regulate the steam temperature to the operating point by producing good transient performances and optimizes the economic function. Real time implementation will be carried out to validate the equivalence of both

controllers. The effectiveness of the controller will be measured by using the performance indices of settling time, rise time, percentage overshoot (%OS), and RMSE.

#### a. PID controller

Figure 5 illustrates the block diagram of the PID controller. The PID controller is given in equation (1) where  $K_p$ ,  $K_i$ , and  $K_d$  are the coefficients for proportional gain, integral gain and derivative gain, respectively whereas  $u(t)$  is the control signal and  $e(t)$  is the error[35].

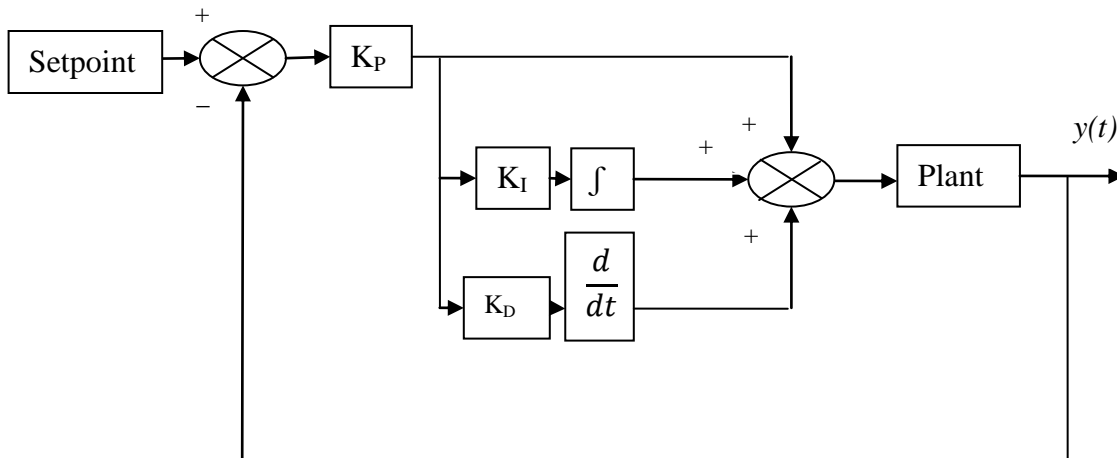

Figure 5. Block diagram of PID controller

$$u(t) = K_p e(t) + K_p K_i \int_{t=0}^{\infty} e(t) dt + K_p K_d \frac{de(t)}{dt} \quad (1)$$

The PID controller is a simple three term controller where the parameters of proportional gain ( $K_p$ ), integral gain ( $K_i$ ) and derivative gain ( $K_d$ ) were tuned using Ziegler-Nichols method. The PID parameters are tabulated in Table 1. However, fine tuning was applied to ensure an optimum result. The sampling period,  $T_s$  is 1 second.

Table 1: PID parameters using Ziegler-Nichols method

Parameter	Value
$K_p$	0.013

$K_i$	0.0000271
$K_d$	31.2

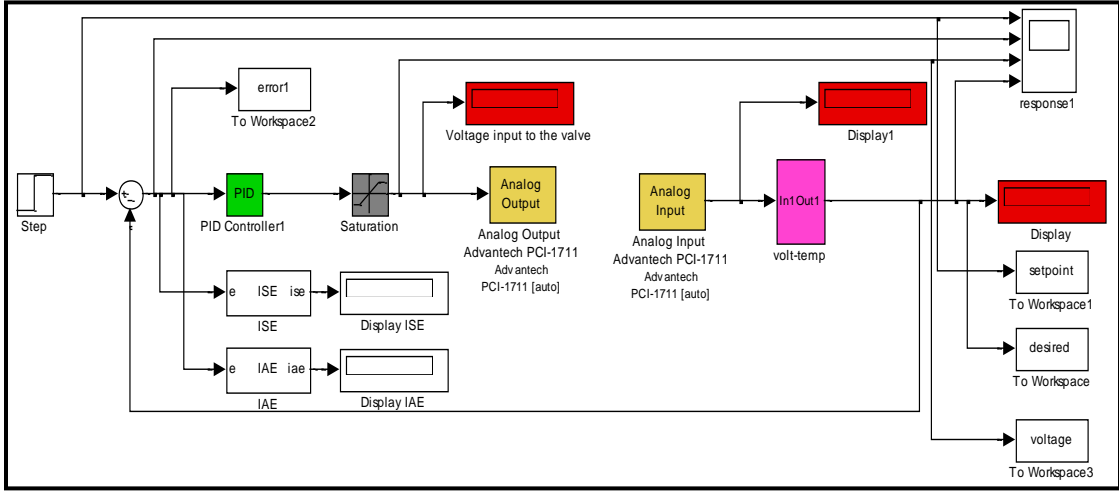

Figure 6. Simulink block diagram of PID controller

b. Self-tuning fuzzy PID controller (STFPID)

The self-tuning fuzzy PID (STFPID) controller is designed with the purposed to evaluate the degree of improvement given by STFPID for temperature control compared with the conventional PID controller. Figure 7 shows the block diagram of a steam temperature control using STFPID controller. In STFPID controller, the fuzzy tuner will automatically tune the parameters of PID which are  $K_p$ ,  $K_i$  and  $K_d$ .

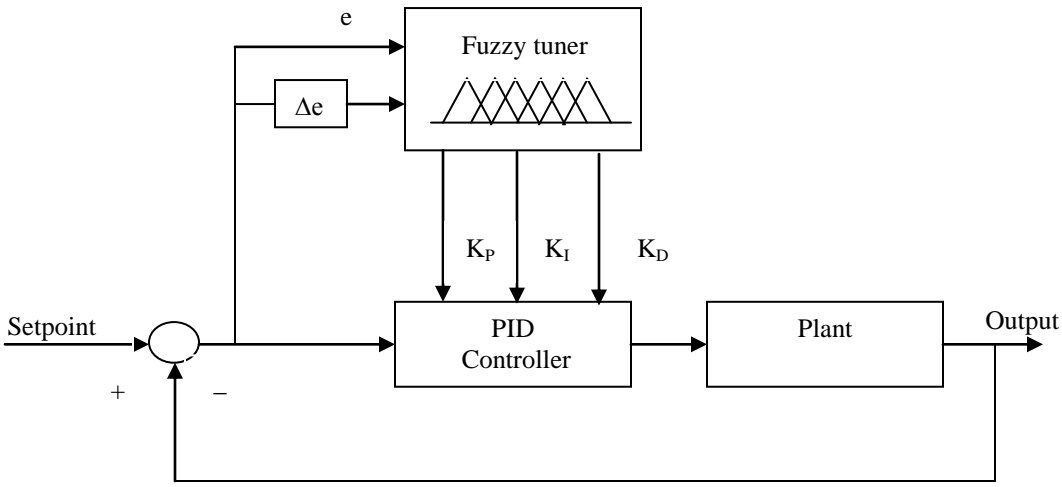

Figure 7. The block diagram of self-tuning fuzzy PID controller



The self-tuning fuzzy PID controller is the controller that applied the fuzzy tuner to tune automatically the PID coefficients,  $K_p$ ,  $K_i$ , and  $K_d$  [25, 26, 36]. The reference setpoint was set at  $90^\circ\text{C}$ . Firstly, two input variables must be defined in terms of linguistics form that is error,  $e(t)$  and derivative of error,  $de(t)/d(t)$ . According to the current value of  $e(t)$  and  $de(t)/d(t)$ , fuzzy will automatically tune the three outputs of the PID controller which are  $K_p'$ ,  $K_i'$  and  $K_d'$ . Figure 8 depicts the connection diagram of the fuzzy system by implementing Mamdani based fuzzy inference system.

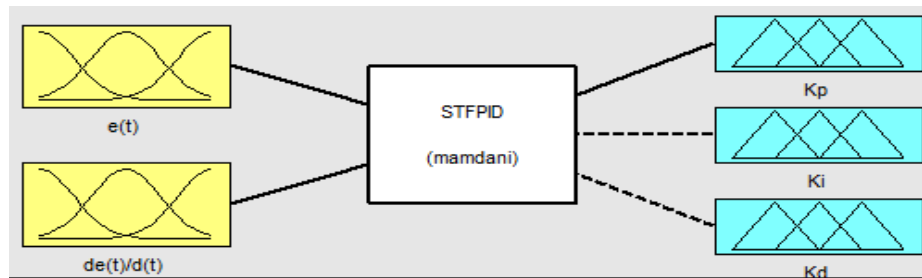

Figure 8. Mamdani fuzzy inference block

In this study, the range of each PID parameter was determined based on the optimum fine tune in the simulation of PID controller using ZN. So, the range of  $K_p$ ,  $K_i$  and  $K_d$  are  $K_p \in [1, 10]$ ,  $K_i \in [0.000001, 0.00001]$  and  $K_d \in [10, 100]$ , respectively. Therefore, they can be calibrated over the range  $[0, 1]$  as below[25]:

$$K_p' = \frac{K_p - K_{p \min}}{K_{p \max} - K_{p \min}} \quad K_i' = \frac{K_i - K_{i \min}}{K_{i \max} - K_{i \min}} \quad K_d' = \frac{K_d - K_{d \min}}{K_{d \max} - K_{d \min}}$$

Hence, the equations for all PID parameters are as follows;

$$K_p = 9K_p' + 1, K_i = 0.000009K_i' + 0.000001 \text{ and } K_d = 90K_d' + 10$$

The membership functions of the  $e(t)$ ,  $de(t)/d(t)$  and output  $K_p'$ ,  $K_i'$  and  $K_d'$  using 5 membership functions are shown in Figure 9, Figure 10 and Figure 11 consecutively. All the linguistic variables were present by the combination of trapezoidal and triangular shape membership functions. The linguistic variables were set based on the characteristics and specification of the hydro-diffusion system.

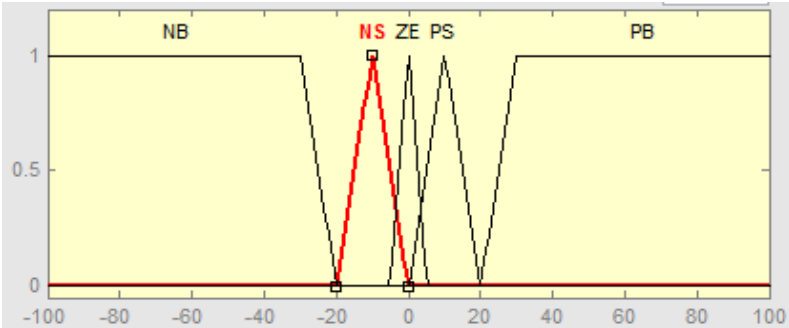

Figure 9. Error membership function

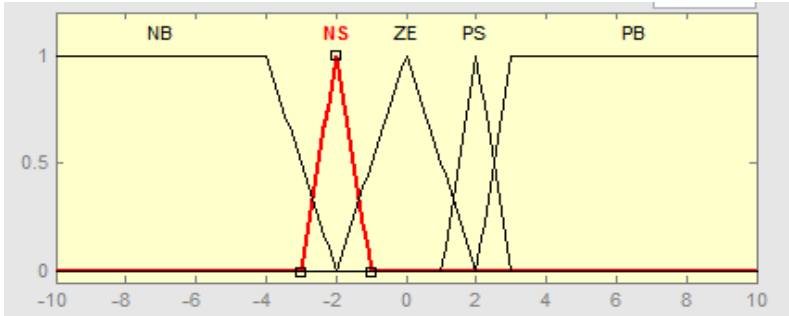

Figure 10. Derivative of error membership function

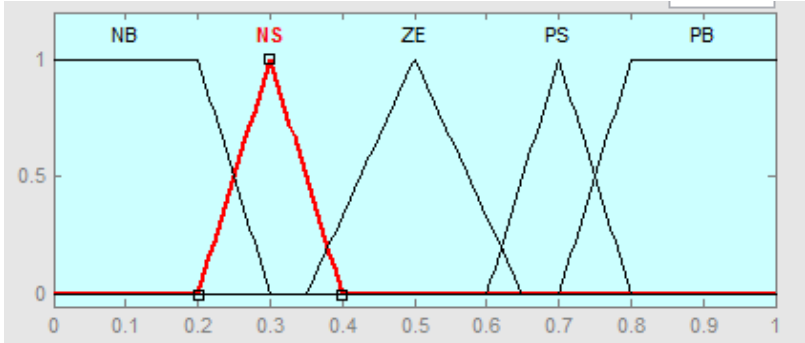

Figure 11.  $K_p'$ ,  $K_i'$ ,  $K_d'$  membership function

The IF-THEN rules were applied during computation algorithms. In this study, the rule base was built based on practical experience and knowledge about the plant to be controlled. The IF-THEN rules using 5 membership functions are summarized in Table 2.

Table 2: The IF-THEN rules using 7 membership functions for STFPID controller

$e(t)$	<b>NB</b>	<b>NS</b>	<b>ZE</b>	<b>PS</b>	<b>PB</b>
$de(t)/dt$					
<b>NB</b>	NB	NB	PS	PB	PB
<b>NS</b>	NB	NB	ZE	PB	PB
<b>ZE</b>	NB	NS	ZE	PS	PB
<b>PS</b>	NB	NB	ZE	PB	PB
<b>PB</b>	NB	NB	NS	PB	PB

Hence, the fuzzy rule can be read using IF-THEN rule as below:

*IF  $e(t)$  is NB and  $de(t)/d(t)$  is NB THEN output is NB*

Figure 12 shows the simulink block diagram for real time STFPID controller.

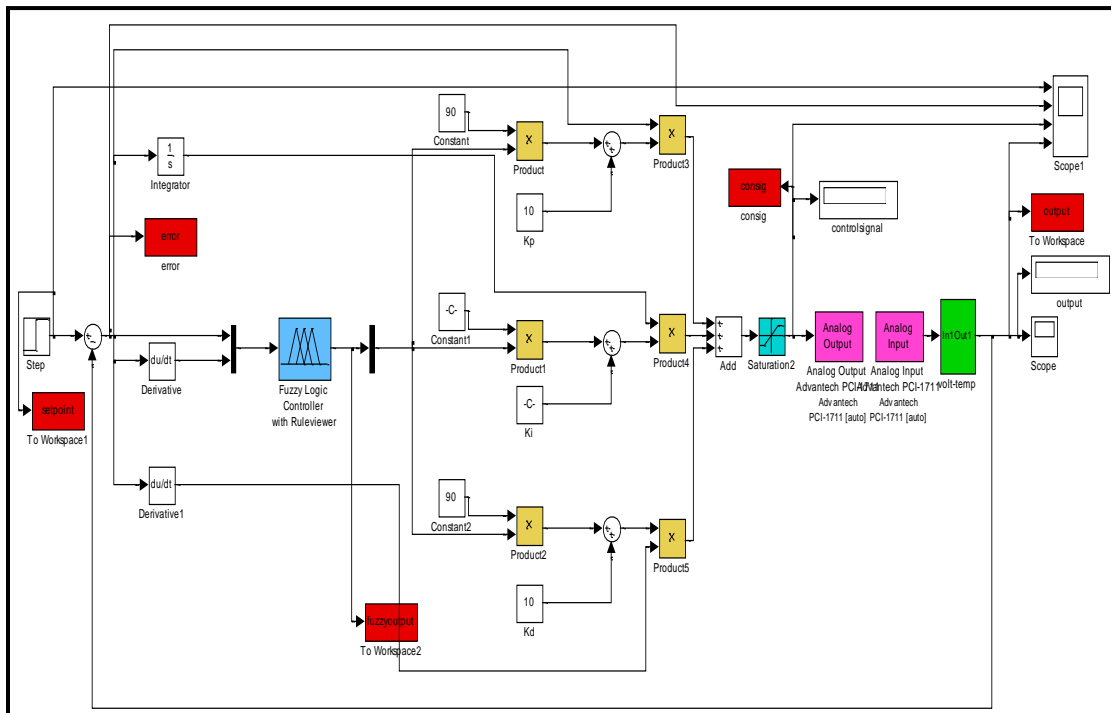

Figure 12. Simulink block diagram for real time implementation of STFPID controller

### c. Robustness test

In order to evaluate the robustness of the PID and STFPID controller in controlling the steam temperature for extraction process, two robustness tests have been carried out [37-40]. The tests are: (1) set point tracking and (2) introduces a load disturbance

(1) Set point tracking- the output is expected to follow the reference signal,  $r(k)$  with the objective to minimize the error between the output and desired response.

$$r(k) = \begin{cases} 27^{\circ}C & ; \text{ for } 0 < k < 2400 \\ 60^{\circ}C & ; \text{ for } 2401 < k < 4400 \\ 80^{\circ}C & ; \text{ for } 4401 < k < 6400 \\ 90^{\circ}C & ; \text{ for } 6401 < k < 8400 \end{cases}$$

(2) Load disturbance- each controller will be introduced to the disturbance by cut off the power supply to the heater from 1.5kW to 0W for 30 seconds. It starts at sample 1000<sup>th</sup> until 1030<sup>th</sup> (during steady state condition). Robustness of the controller design will be based on how fast the output tackles back to the desired set point.

## IV. RESULT AND DISCUSSION

The findings for the real time implementation of PID and STFPID-5 (refer to 5 memberships function) controllers are shown in Figure 13 and Figure 14, respectively. Meanwhile, Table 3 summarized the comparative analysis performance for both controllers. As can be seen from both step response results, real time experiments on controlling the steam temperature in the essential oil process are tested under long time delay which is approximately 2400 s. The PID and STFPID-5 controller schemes are able to cope with the long time delay in the hydro-diffusion system. In general, the intention to design controllers was achieved when all proposed controllers are able to drive the steam temperature to the set point.

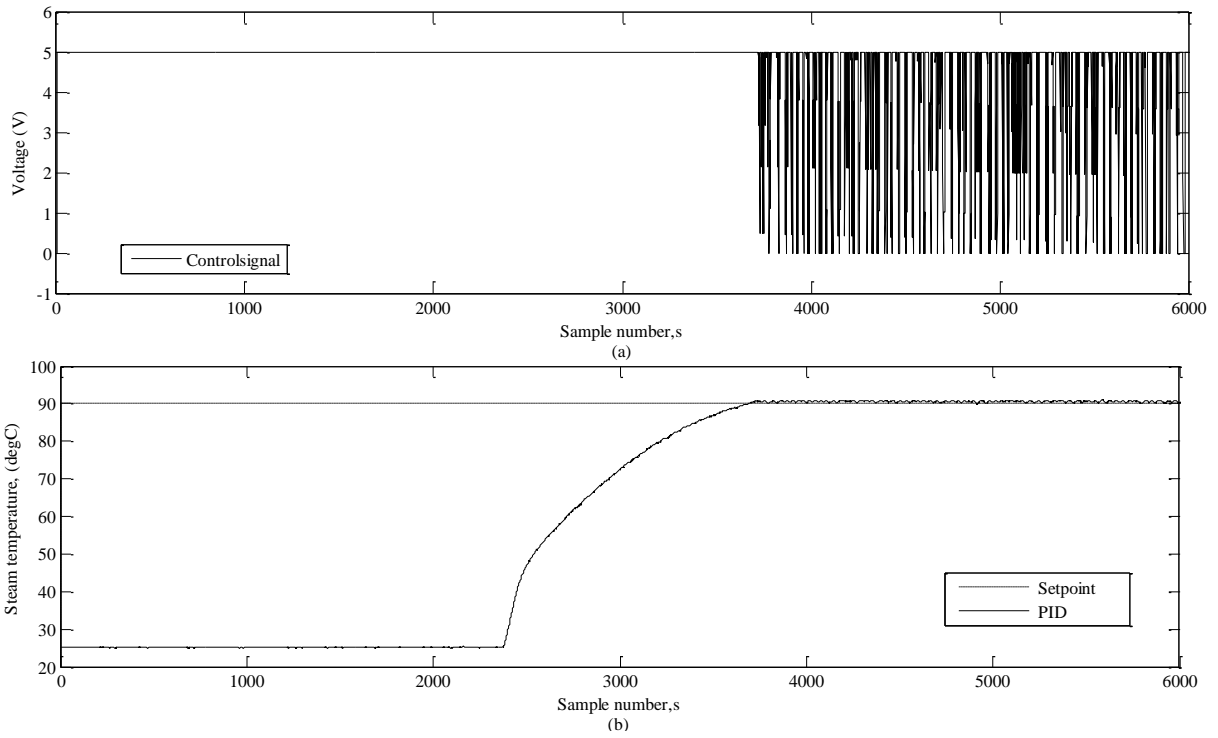

Figure 13. Real time performance of PID controller for steam temperature, (a) control signal, (b) output

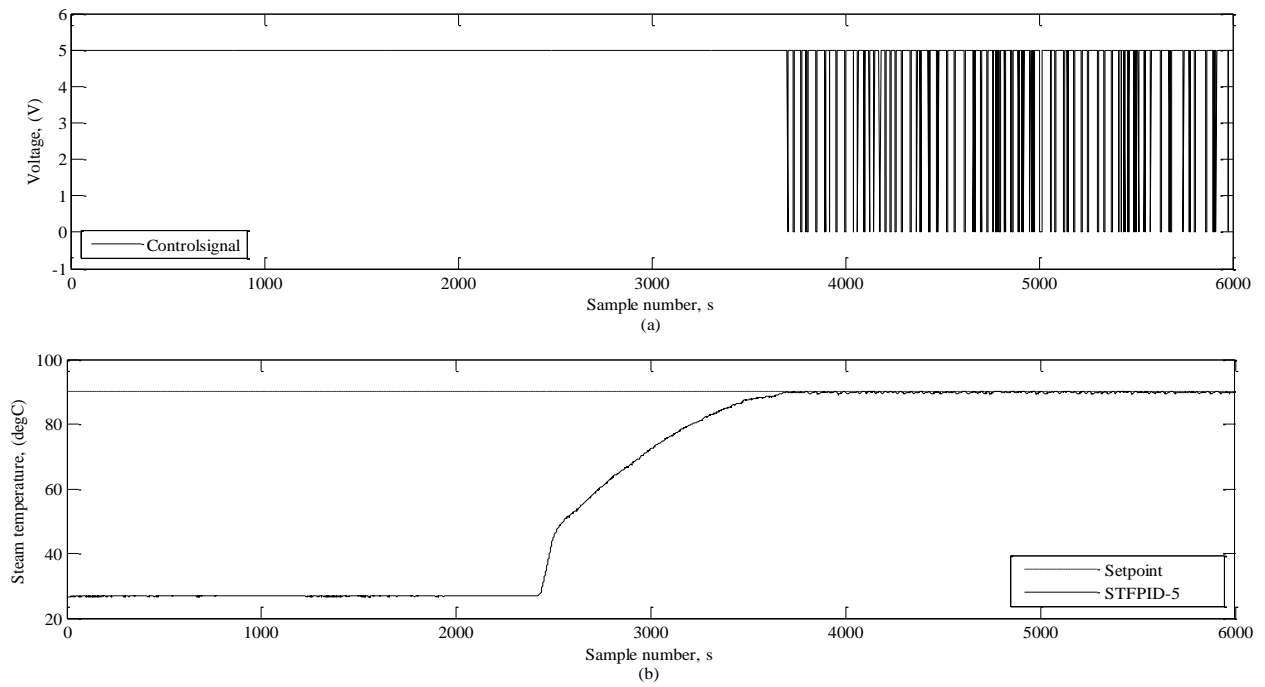

Figure 14. Real time performance of STFPID-5 controller for steam temperature control, (a) control signal, (b) output

Table 3 Analysis performance for real time implementation of PID and STFPID-5 controllers

No	Controller	Rise time, (s)	Settling time, (s)	% OS	RMSE
1	PID	959	3657	0.3340	0.6034
2	STFPID-5	882	3634	0.3364	0.3316

From the Figure 13(a) and Figure 14(a), it can be observed that from the beginning of the experiment the control signal is maintained at 5V. However, once the output achieves the desired set point (90 °C), the control signal start varies between 0V to 5V. The PID controller is able to regulate the steam temperature in order to achieve the desired set point with large rise time which is 959 s. The PID controller also takes the longest time to settle down and maintain at a steady-state which is 3657 s. The results show that STFPID-5 controller offers better performance compared to the PID controller on reducing rise time (882 s), settling time (3634 s) and minimized ripple at steady state (RMSE=0.3316). It is apparent that the output controlled by STFPID-5 controller is much faster than that controlled by PID controller, i.e faster rise time and settling time. The rise time for STFPID-5 is about 77 s less than that PID controller. The discrepancy is quite significant. The STFPID-5 pushes the response to attain steady state much faster. Consequently, it will significantly reduce the power consumption. It is observed that the percentage of overshoot is shown to be the smallest for PID controller, which is 0.3340 % compared with the STFPID-5 with 0.3364%. It is implied that faster rise time will produce large overshoot in the output performance. However, the RMSE results generally agree on the rise time and settling time results where the RMSE value of PID controller is slightly higher than STFPID-5 controller. The PID controller's RMSE value is 0.6034.

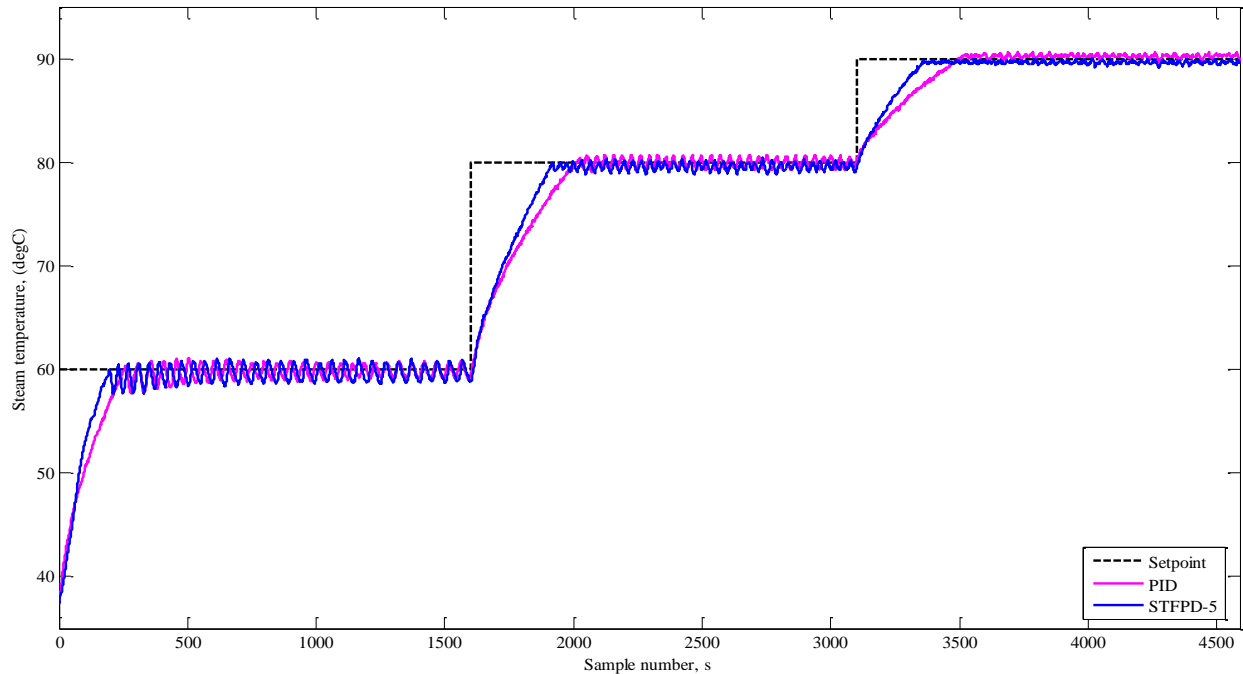

Figure 15. The PID and STFPID-5 performances on set point tracking

Figure 15 shows the combined result for set point change performances using PID and STFPID-5 controller. From the set point change test, all developed controllers are able to track the changes of set point whether in small or large set point change. The PID and STFPID-5 controller produce satisfactory results. However, the results show that STFPID-5 offer better performances especially on providing fast rise time, settling time and less overshoot compares to PID controller. The STFPID-5 have precisely enhanced its performance when facing a set point change. This improvement generally will lead to faster extraction process. Tables 4, 5 and 6 summarized the performance of the PID and STFPID-5 on track the set point.

Table 4: Analysis performance for PID and STFPID-5 on track set point change (at 60 °C)

No	Controller	Rise time, (s)	Settling time, (s)	%OS	RMSE
1	PID	191	1594	1.1108	0.7129
3	STFPID-5	129	1581	0.8354	0.7372
STFPID-5 compared with PID		62 s (>1 min)	13 s	0.2754	-0.0243

Table 5: Analysis performance for PID and STFPID-5 on track set point change (at 80 °C)

No	Controller	Rise time, (s)	Settling time, (s)	%OS	RMSE
1	PID	328	1495	0.7462	0.4087
3	STFPID-5	245	1484	0.4953	0.5677
STFPID-5 compared with PID		83 s (>1 min)	11 s	0.2509	-0.1590

Table 6: Analysis performance for PID and STFPID-5 on track set point change (at 90 °C)

No	Controller	Rise time, (s)	Settling time, (s)	%OS	RMSE
1	PID	334	1496	0.6723	0.3135
3	STFPID-5	206	1478	0.3249	0.3040
STFPID-5 compared with PID		128 s (>2 min)	18 s	0.3474	0.0095

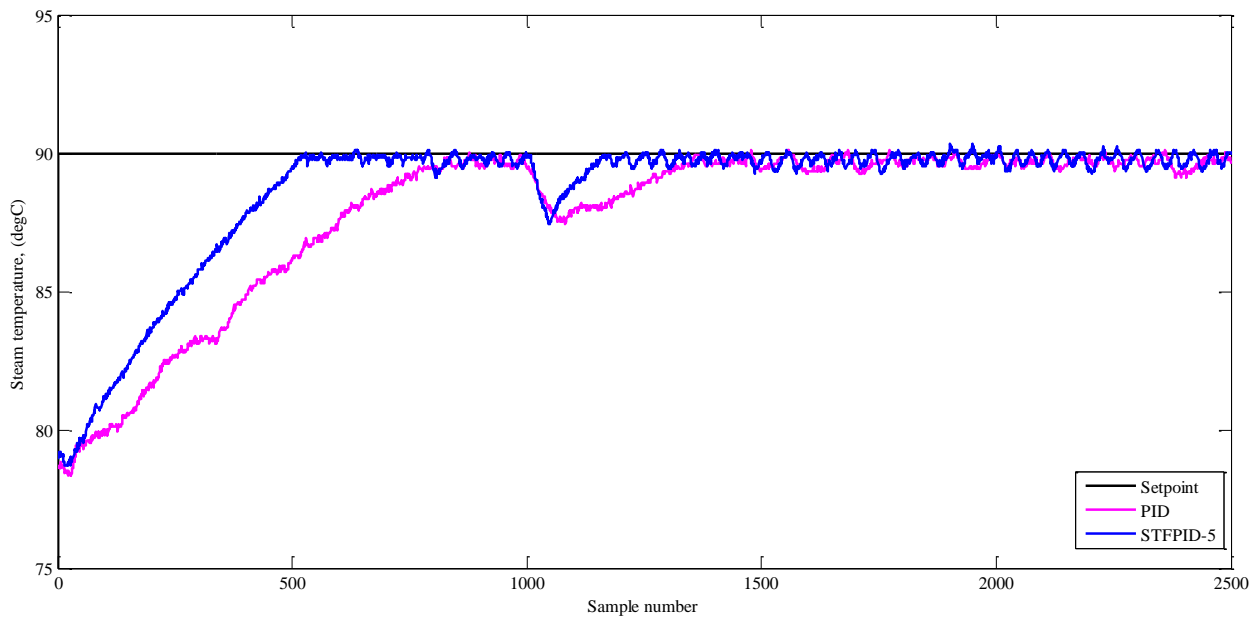

Figure 16. The PID and STFPID-5 performances on recovering load disturbance



Table 7: Analysis of real time performance of the PID and STFPID-5 controller on recovering load disturbance

No	Controller	$T_{\min}$	Recovery time (s)
1	PID	87.42 °C	386
2	STFPID-5	87.42 °C	101
STFPID-5 compared with the PID			285 (> 4 min)

Figure 16 shows a comparison performance between the PID and STFPID-5 control strategies for steam temperature on the hydro-diffusion system with load disturbance. Table 7 summarized the results of PID and STFPID-5 controller on recovering load disturbance. Robustness of the controller design will be based on the how fast output tackles back the desired set point. From the result in the Table 7, after introducing the disturbance at sample 1000<sup>th</sup>, steam temperature decrease with  $T_{\min}= 87.42$  °C, and  $T_{\min}= 87.42$  °C for the PID and STFPID-5 controllers, respectively. All controllers are able to capture back the set point after the system was disturbed during running process. However, this result revealed that the good robustness of the STFPID-5 controller since the PID controller take the longest time to recover load disturbance with 386 s. The STFPID-5 takes 285 s less than PID controller.

## V. CONCLUSION

There are two controllers that were developed to regulate the steam temperature in hydro-diffusion steam distillation essential oil extraction system. The controller performances based on the real time implementation were focused on transient response and steady state response. The step response analysis shows that the intention to design controllers was achieved when all proposed controllers are able to drive the steam temperature to the desired setpoint. Two robustness test were carried out which are set point tracking and load disturbance. From the step change test, all developed controllers were able to track the changes of set point whether in small

or large set point change. The controllers were also able to return to the set point after the system was disturbed. Comparatively, the results show that STFPID-5 produced better performances especially on providing shorter rise time, settling time and lower RMSE.

#### ACKNOWLEDGMENTS

This work was conducted on the data gathered at the Faculty of Electrical Engineering, UiTM Shah Alam. The authors would like to thank all staff involved, RMI UiTM and JPbSM UiTM.

#### REFERENCES

- [1] F. Chemat, M. E. Lucchesi, J. Smadja, L. Favretto, G. Colnaghi, and F. Visinoni, "Microwave accelerated steam distillation of essential oil from lavender: A rapid, clean and environmentally friendly approach," *Analytica Chimica Acta*, vol. 555, pp. 157–160, 2006.
- [2] J. M. Roldan-Gutierrez, J. Ruiz-Jimenez, and M. D. L. d. Castro, "Ultrasound-assisted dynamic extraction of valuable compounds from aromatic plants and flowers as compared with steam distillation and superheated liquid extraction," *Talanta*, vol. 75, pp. 1369–1375, 2008.
- [3] A. Donelian, L. H. C. Carlsonb, T. J. Lopesa, and R. A. F. Machado, "Comparison of extraction of patchouli (*Pogostemon cablin*) essential oil with supercritical CO<sub>2</sub> and by steam distillation," *The Journal of Supercritical Fluids*, vol. 48, pp. 15–20, 2009.
- [4] M. Khajeh, Y. Yaminib, and S. Shariati, "Comparison of essential oils compositions of *Nepeta persica* obtained by supercritical carbon dioxide extraction and steam distillation methods," *Food and Bioproducts Processing*, vol. 88, pp. 227–232, 2010.
- [5] M. E. Lucchesi, F. Chemat, and J. Smadja, "Solvent-free microwave extraction of essential oil from aromatic herbs: comparison with conventional hydro-distillation," *Journal of Chromatography A*, vol. 1043, pp. 323–327, 2004.
- [6] E. L. Galvão, H. B. d. Sant'Ana, H. N. M. Oliveira, A.V.Souza, and E. M. B. D. Sousa, "Influence of Temperature in the Kinetics Extraction of the *Cymbopogon Winterianus* j. oil with Dense Carbon Dioxide," *2nd Mercosur Congress on Chemical Engineering, 4th Mercosur Congress on Process Systems Engineering*.
- [7] S. Sayyar, Z. Z. Abidin, R. Yunus, and A. Muhammad, "Extraction of Oil from *Jatropha* Seeds-Optimization and Kinetics," *American Journal of Applied Sciences*, vol. 6, pp. 1390-1395, 2009.
- [8] N. Bousbia, M. A. Vian, M. A.Ferhat, E. Petitcolas, B. Y.Meklati, and F. Chemat, "Comparison of two isolation methods for essential oil from rosemary leaves:Hydrodistillation and microwave hydrodiffusion and gravity," *Journal of Food Chemistry*, vol. 114, pp. 355-362, 2009.
- [9] E. S. Giray, S. Kirici, D. A. Kaya, M. Turk, O. Sonmez, and M. Inan, "Comparing the effect of sub-critical water extraction with conventional extractipn methods on the chemical composition of *Lavandula stoechas*," *Talanta*, vol. 74, pp. 930-935, 2008.

- [10] A.Arce, A.Pobudkowska, O.Rodriguez, and A.Soto, "Citrus essential oil terpenless by extraction using 1-ethyl-3-methylimidazolium ethylsulfate ionic liquid: Effect of temperature," *Chemical Engineering Journal*, vol. 133, pp. 213-218, 2007.
- [11] S. Chanthaphon, S. Chanthachum, and T. Hongpattarakere, "Antimicrobial activities of essential oils and crude extracts from tropical Citrus spp. against food-related microorganisms," *Songklanakar Journal of Science and Technology*, vol. 30, pp. 125-131, 2008.
- [12] G. Wenqiang, L. Shufen, Y. Ruixiang, T. Shaokun, and Q. Can, "Comparison of essential oils of clove buds extracted with supercritical carbon dioxide and other three traditional extraction methods," *Food Chemistry*, vol. 101, pp. 1558–1564, 2007.
- [13] H. Ebrahimzadeh, Y. Yamini, F. Sefidkon, M. Chaloosi, and S. M. Pourmortazavi, "Chemical composition of the essential oil and supercritical CO<sub>2</sub> extracts of *Zataria multiflora* Boiss," *Food Chemistry*, vol. 83, pp. 357–361, 2003.
- [14] R. Adnan, M. Tajjudin, N. Ishak, H. Ismail, M. H. F. Rahiman, and N. M. Arshad, "Comparison between self-tuning Fuzzy-PID and Pole-Placement PID with application to saturated steam temperature regulation," *International Conference on System Engineering and Technology (ICSET)*, pp. 1-5, 11-12 Sept. 2012.
- [15] M. Z. Ozel and H. Kaymaz, "Superheated water extraction, steam distillation and Soxhlet extraction of essential oils of *Origanum onites*," *Analytical and bioanalytical chemistry* vol. 379, pp. 1127-1133, 2004.
- [16] C. Deng, X. Xu, N. Yao, N. Li, and X. Zhang, "Rapid determination of essential oil compounds in *Artemisia Selengensis* Turcz by gas chromatography-mass spectrometry with microwave distillation and simultaneous solid-phase microextraction," *Analytica Chimica Acta*, vol. 556, pp. 289-294, 2006.
- [17] G. Song, C. Deng, D. Wu, and Y. Hu, "Comparison of Headspace Solid-Phase Microextraction with Solvent Extraction for the Analysis of the Volatile Constituents of Leaf Twigs of Chinese Arborvitae " *Chromotographia* vol. 59, pp. 769-774, 2003.
- [18] N. A. Mohamed, "Study on Important Parameters Affecting the Hydrodistillation for Ginger Oil Production," 2005.
- [19] E. Cassel, R. M. F. Vargas, N. Martinez, D. Lorenzo, and E. Dellacassa, "Steam distillation modeling for essential oil extraction process," *Industrial Crops and Products*, vol. 29, pp. 171–176, 2009.
- [20] N. C. Nikolic, S. M. Cakic, S. M. Novakovi, M. D. Cvetkovic, and M. Z. Stankovic, "Effect of Extraction Techniques on Yield and Composition of Soybean Oil," *Macedonian Journal of Chemistry and Chemical Engineering* vol. 28, pp. 173-179, 2009.
- [21] C. C. Lee, "Fuzzy Logic in Control Systems: Fuzzy Logic Controller-Part I," *IEEE Transactions On Systems*, vol. 20, pp. 404-418, 1990.
- [22] S. G. Cao, N. W. Rees, and G. Feng, "Analysis and Design for a Class of Complex Control Systems Part II: Fuzzy Controller Design," *Automatica*, vol. 33, pp. 1029-1039, 1997.
- [23] Z. Xiaodong, X. Senlin, and Z. Hongbo, "A New Strategy for Batch Reactor's Temperature Control," *WRI World Congress on Computer Science and Information Engineering*, vol. 5, pp. 56-61, 2009.
- [24] N. N. Mohammad, N. Kasuan, M. H. F. Rahiman, and M. N. Taib, "Steam Temperature Control Using Fuzzy Logic for Steam Distillation Essential Oil Extraction Process," *IEEE Control and System Graduate Research Colloquium*, pp. 53-58, 2011.

- [25] Zulfatman and M. F. Rahmat, "Application of self-tuning fuzzy PID controller on industrial hydraulic actuator using system identification approach," *International Journal on Smart Sensing and Intelligent Systems*, vol. 2, pp. 246-261, 2009.
- [26] N. B. Kha and A. Kyoung-Kwan, "Position Control of Shape Memory Alloy Actuators by Using Self Tuning Fuzzy PID Controller," *1ST IEEE Conference on Industrial Electronics and Applications*, , pp. 1-5, 2006.
- [27] G. Zhiqiang, T. A. Trautzsch, and J. G. Dawson, "A stable self-tuning fuzzy logic control system for industrial temperature regulation," *IEEE Transactions on Industry Applications*, vol. 38, pp. 414-424, 2002.
- [28] P. Isomursu and T. Rauma, "A self-tuning fuzzy logic controller for temperature control of superheated steam," *IEEE World Congress on Computational Intelligence., Proceedings of the Third IEEE Conference on Fuzzy Systems*, vol. 3, pp. 1560-1563 1994.
- [29] K. Sinthipsomboon, I. Hunsacharoonroj, J. Khedari, W. Pongaen, and P. Pratumswan, "A hybrid of fuzzy and fuzzy self-tuning PID controller for servo electro-hydraulic system," *Industrial Electronics and Applications (ICIEA), 2011 6th IEEE Conference on*, pp. 220-225, 21-23 June 2011.
- [30] W. H. Bare, R. J. Mulholland, and S. S. Sofer, "Design of a self-tuning rule based controller for a gasoline refinery catalytic reformer," *IEEE Transactions on Automatic Control*, vol. 35, pp. 156-164, 1990.
- [31] T. Ching-Chih and L. Chi-Huang, "Multivariable self-tuning temperature control for plastic injection molding process," *IEEE Transactions on Industry Applications*, vol. 34, pp. 310-318, 1998.
- [32] W. C. Daugherity, B. Rathakrishnan, and J. Yen, "Performance evaluation of a self-tuning fuzzy controller," *IEEE International Conference on Fuzzy Systems*, pp. 389-397, 1992.
- [33] F. Peng, L. Sheng, B. Liu, H. Tong, and S. Liu, "Comparison of different extraction methods: steam distillation, simultaneous distillation and extraction and headspace co-distillation, used for the analysis of the volatile components in aged flue-cured tobacco leaves," *Journal of Chromatography A*, vol. 1040, pp. 1-17, 2004.
- [34] P. Masango, "Cleaner production of essential oils by steam distillation," *Journal of Cleaner Production*, vol. 13, pp. 833-839, 2005.
- [35] T. Hagglund, "An industrial dead-time compensating PI controller," *Control Engineering Practice*, vol. 4, pp. 749-756, 1996.
- [36] K. K. Ahn and D. Q. Truong, "Online tuning fuzzy PID controller using robust extended Kalman filter," *Journal of Process Control*, vol. 19, pp. 1011-1023, 2009.
- [37] N. Kasuan, M. N. Taib, and M. H. F. Rahiman, "Model Reference Adaptive Controller to Regulate Steam Temperature in Distillation Process for Essential Oil Extraction," *7th International Colloquium on Signal Processing and its Applications*, pp. 298-303, 2011.
- [38] R. K. Mudi and N. R. Pal, "A Robust Self-Tuning Scheme for PI- and PD-Type Fuzzy Controllers," *IEEE Transactions On Fuzzy Systems*, vol. 7, pp. 2-16, 1999.
- [39] T. Ching-Chih and H. Chih-Hung, "Model reference adaptive predictive control for a variable-frequency oil-cooling machine," *IEEE Transactions On Industrial Electronics*, vol. 51, pp. 330-339, 2004.
- [40] J. Flores-Cerrillo and J. F. MacGregor, "Latent variable MPC for trajectory tracking in batch processes," *Journal of Process Control*, vol. 15, pp. 651-663, 2005.